

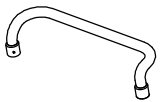





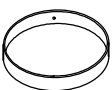

ASSEMBLY INSTRUCTION

ROUND BAR CART

A Handle  2pcs	B Post  4pcs	C Upper Tray  2pcs	D Bottom Tray  1pc
E Wheel With Lock  2pcs	F Wheel  2pcs	G Bolt Ø5/32"x20mm  16pcs	H Screw Ø8x15mm  4pcs
I Spanner M14  1pc	J Allen Key M4  1pc		

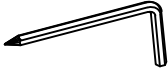
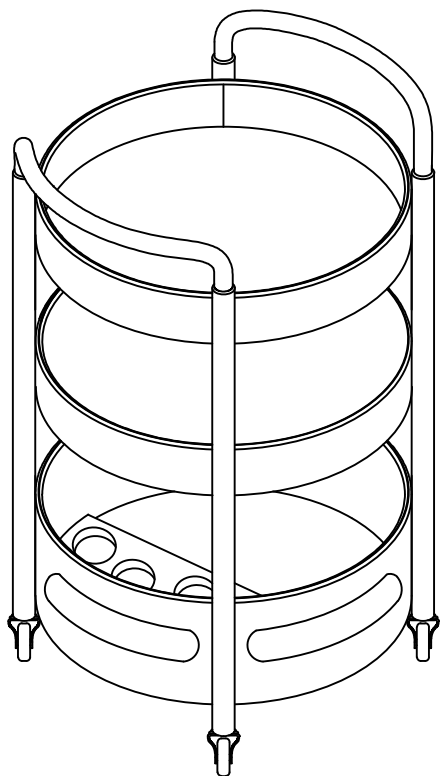

This page lists all the contents included in the box. Please take the time to identify the hardware as well as the individual components to this product. As you unpack and prepare for assembly, place the contents on a carpeted or padded area to protect them from damage.

1 Attach the Post (B) to Upper Tray (C) & Bottom Tray (D) using Bolt (G) by Allen Key (J).

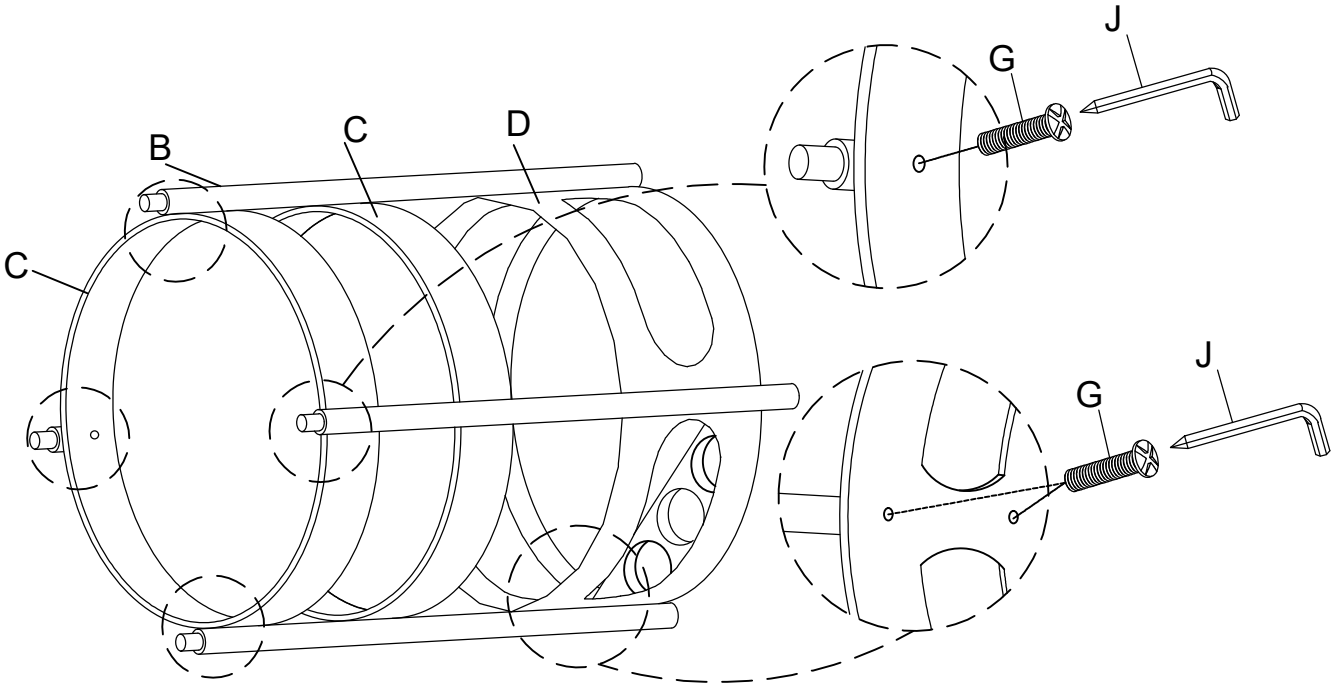

2 Attach to Handle (A) to the top of Post (B) using Screw (H) by Allen Key (J), attach Wheel With Lock (E) & Wheel (F) to the bottom of with Spanner (I).

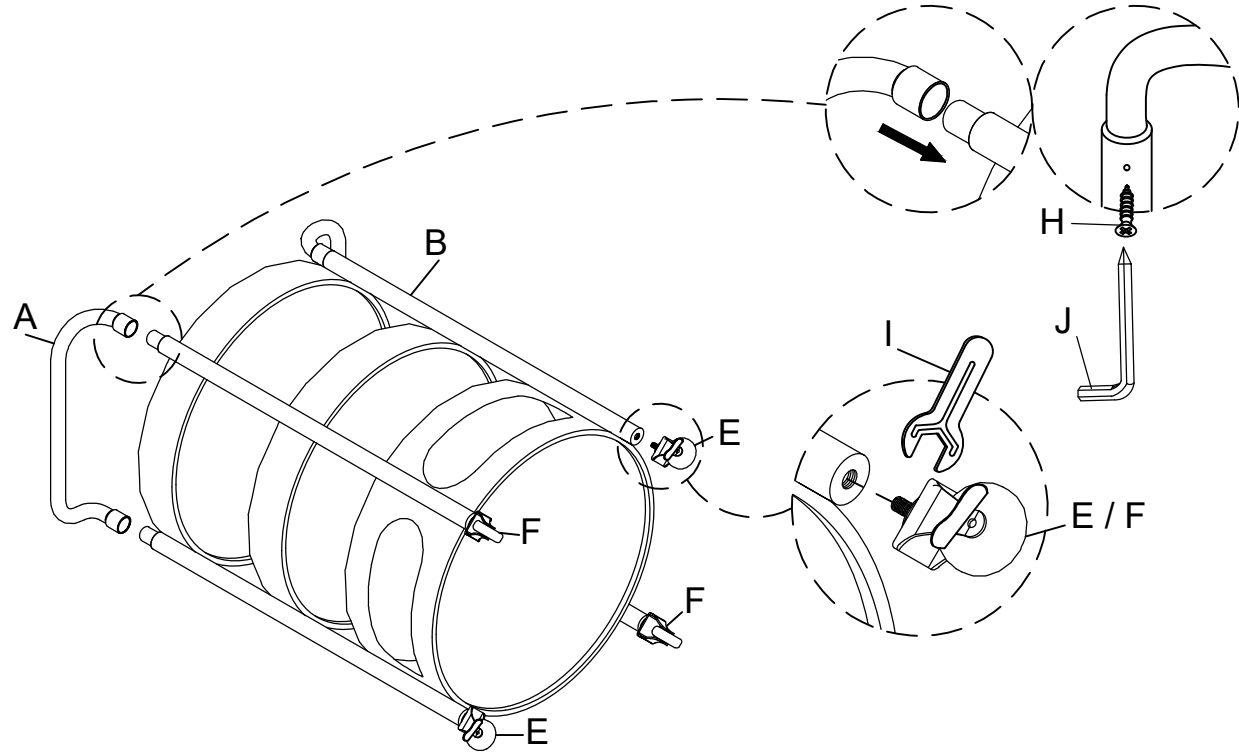

Cleaning & Care

Treat surface with care. Surface is resistant to scratches but is not scratch resistant. Clean surfaces with a dry or damp soft cloth. Do not use abrasive cleaners. Hardware may loosen over time. Periodically check that all connections are tight.