

ASSEMBLY INSTRUCTIONS

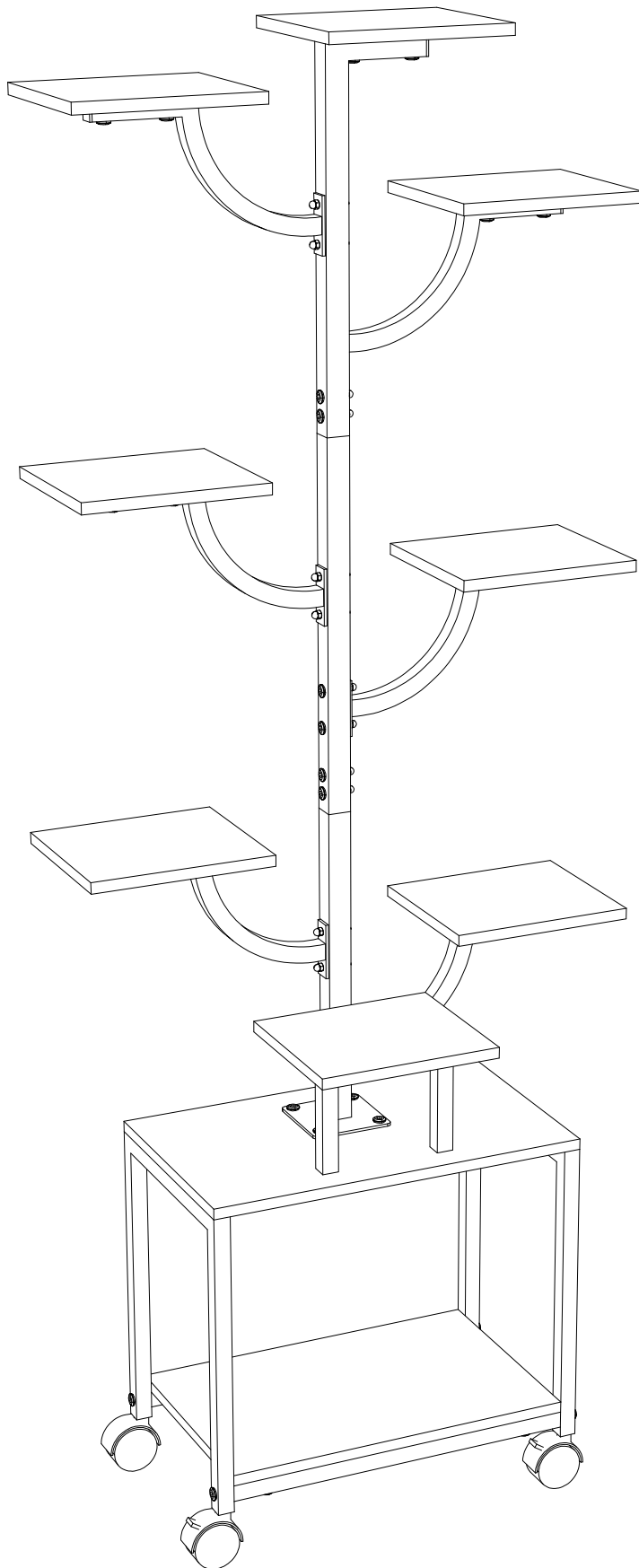

ASSEMBLY OVERVIEW

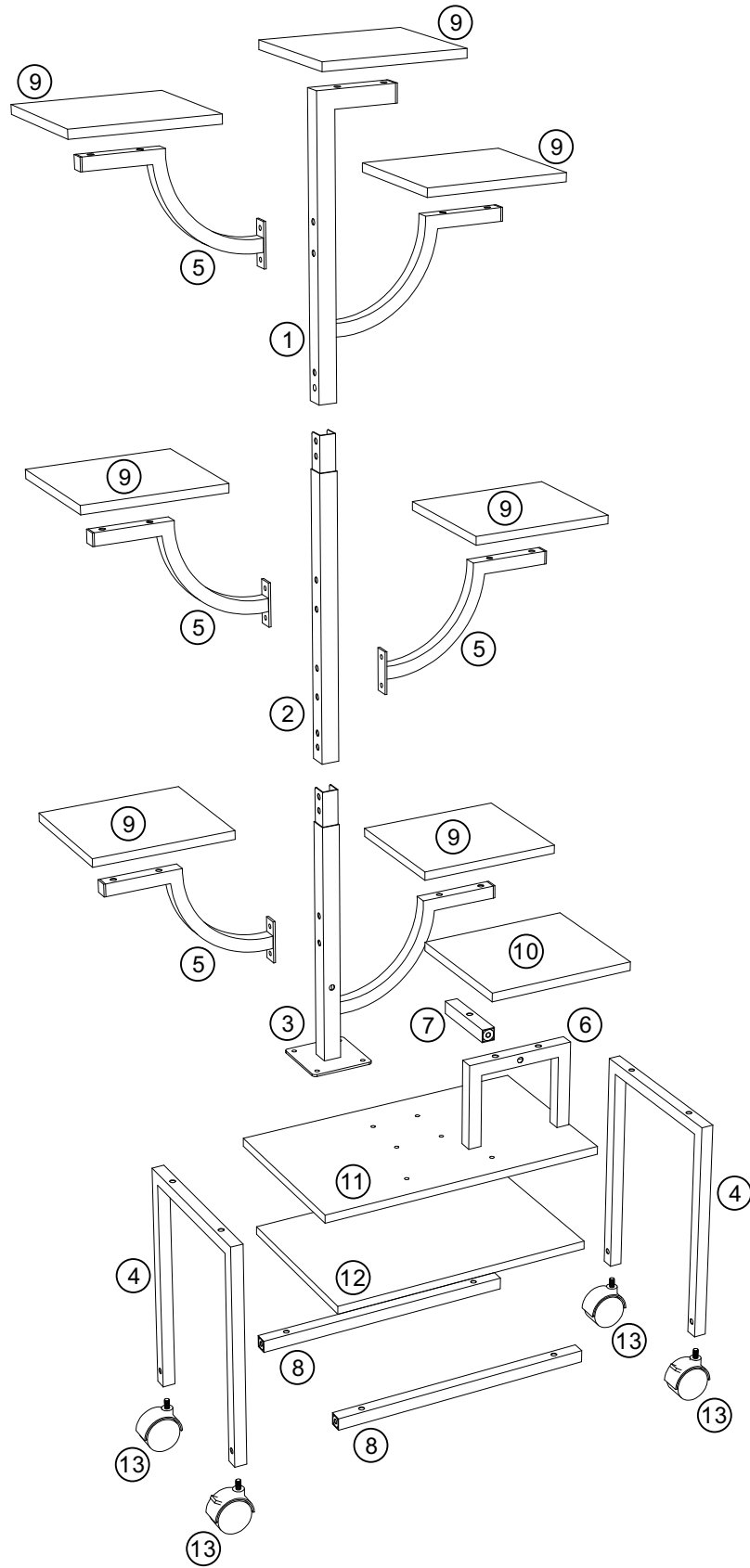

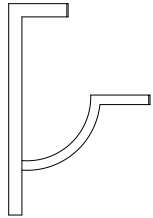
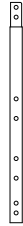
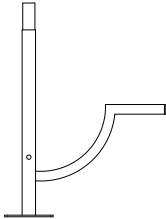
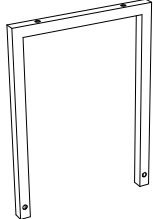
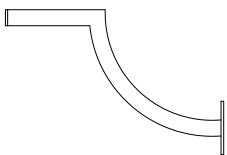

PARTS LIST

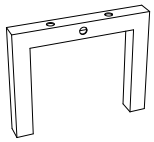
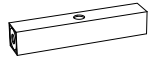
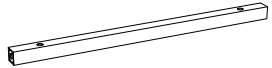
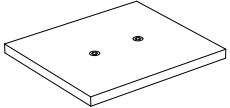
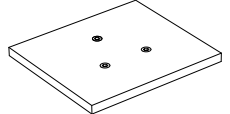
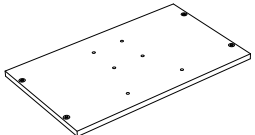
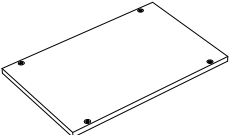
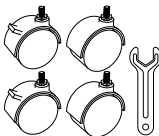
Ref	DESCRIPTON	Visual	Qty
①	Support Frame		1
②	Support Frame		1
③	Support Frame		1
④	Connection Rod		2
⑤	Connection Rod		4

Ref	DESCRIPTON	Visual	Qty
⑥	Connection Rod		1
⑦	Connection Rod		1
⑧	Connection Rod		2
⑨	Support Panel		7
⑩	Support Panel		1
⑪	Support Panel		1
⑫	Support Panel		1
⑬	Caster Wheels		1

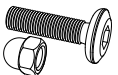
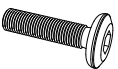
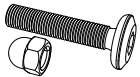
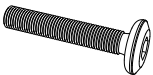
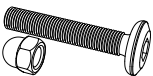
HARDWARE LIST

Ref	DESCRIPTON	Visual	Qty	Spare Qty
A	M6x26mm		4	
B	M6x28mm		30	3
C	M6x33mm		4	
D	M6x38mm		3	
E	M6x38mm		8	1

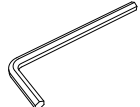
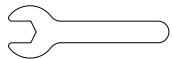
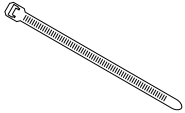
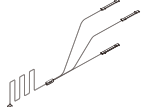
Ref	DESCRIPTON	Visual	Qty	Spare Qty
F	Anti-tip Tie Strap		1	
G	L Wrench		1	
H	Wrench		1	
I	Cable Ties		4	
J	Light Strip		1	

ASSEMBLY INSTRUCTIONS

1

Connect connection rods ⑥ ⑦ and support panel ⑩ by screws (B).
Connect connection rods ⑧ and support panel ⑫ by screws (B).

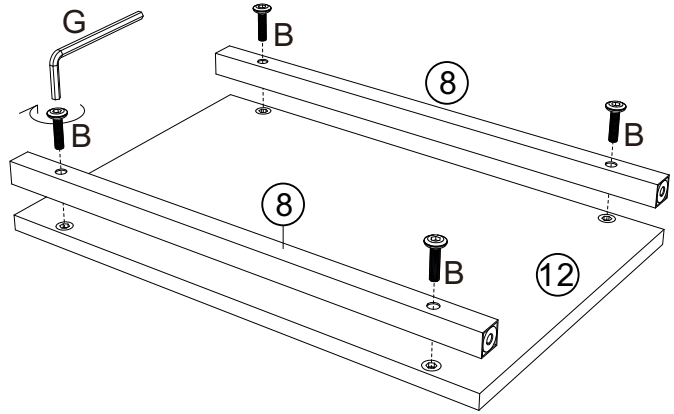
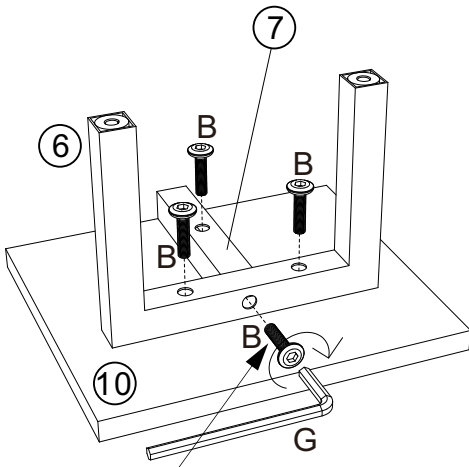

First: Connect connection rod ⑥ and connection rod ⑦ by screw (B).

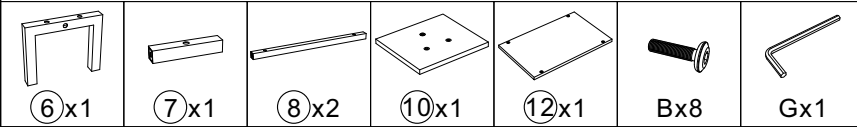

2

Connect support panel ⑪ and connection rods ④ by screws (B).

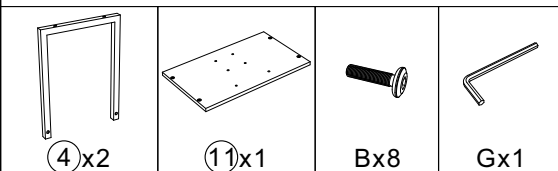
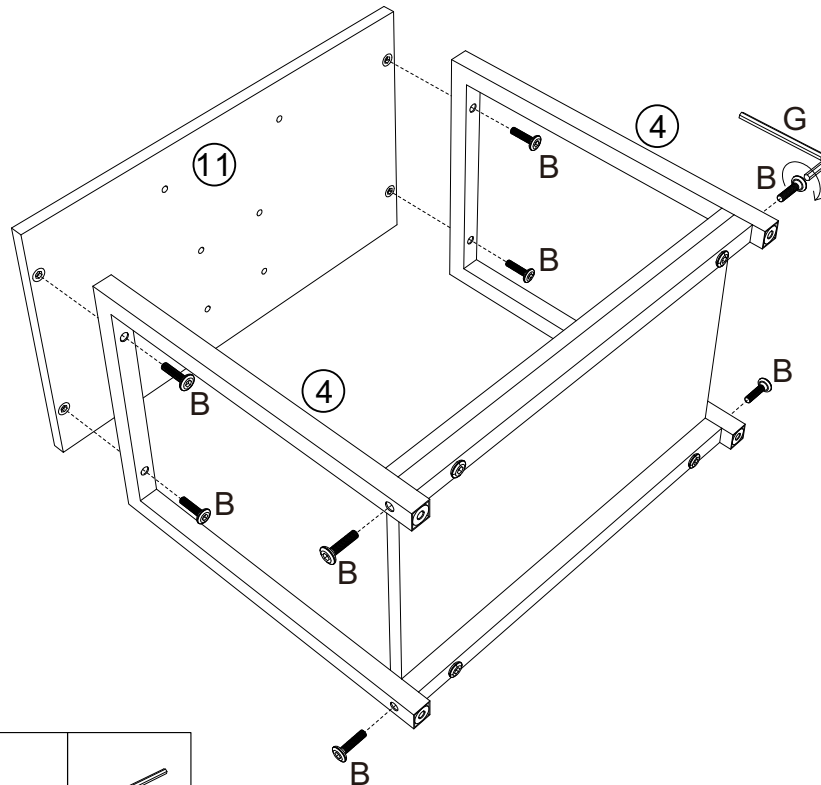

ASSEMBLY INSTRUCTIONS

3

Connect support frame ① and connection rod ⑤ by screws (E).
 Connect support frame ② and connection rods ⑤ by screws (E).
 Connect support frame ③ and connection rod ⑤ by screws (E).

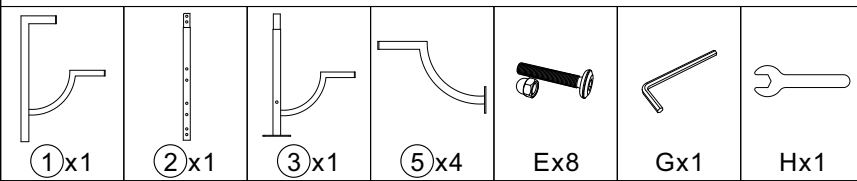
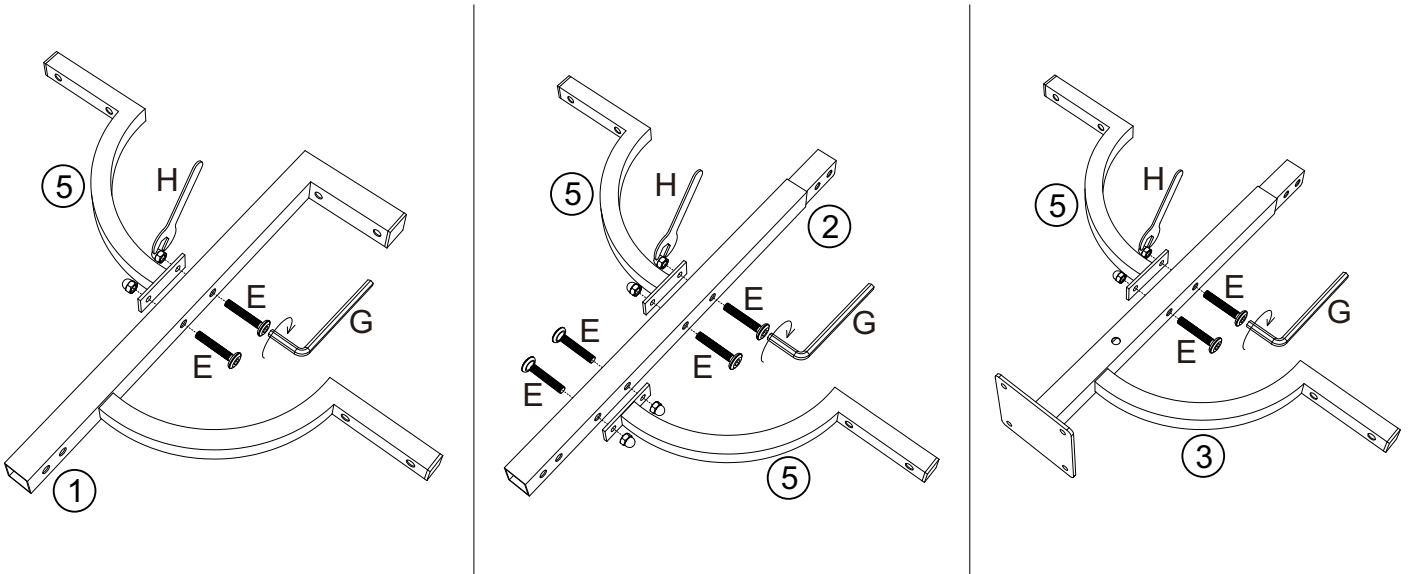

4

Step 1: Connect support frame ③ and support panel ⑪ by screws (A).
Step 2: Connect support frame ② and support frame ③ by screws (C).
Step 3: Connect support frame ① and support frame ② by screws (C).

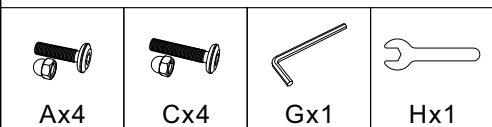
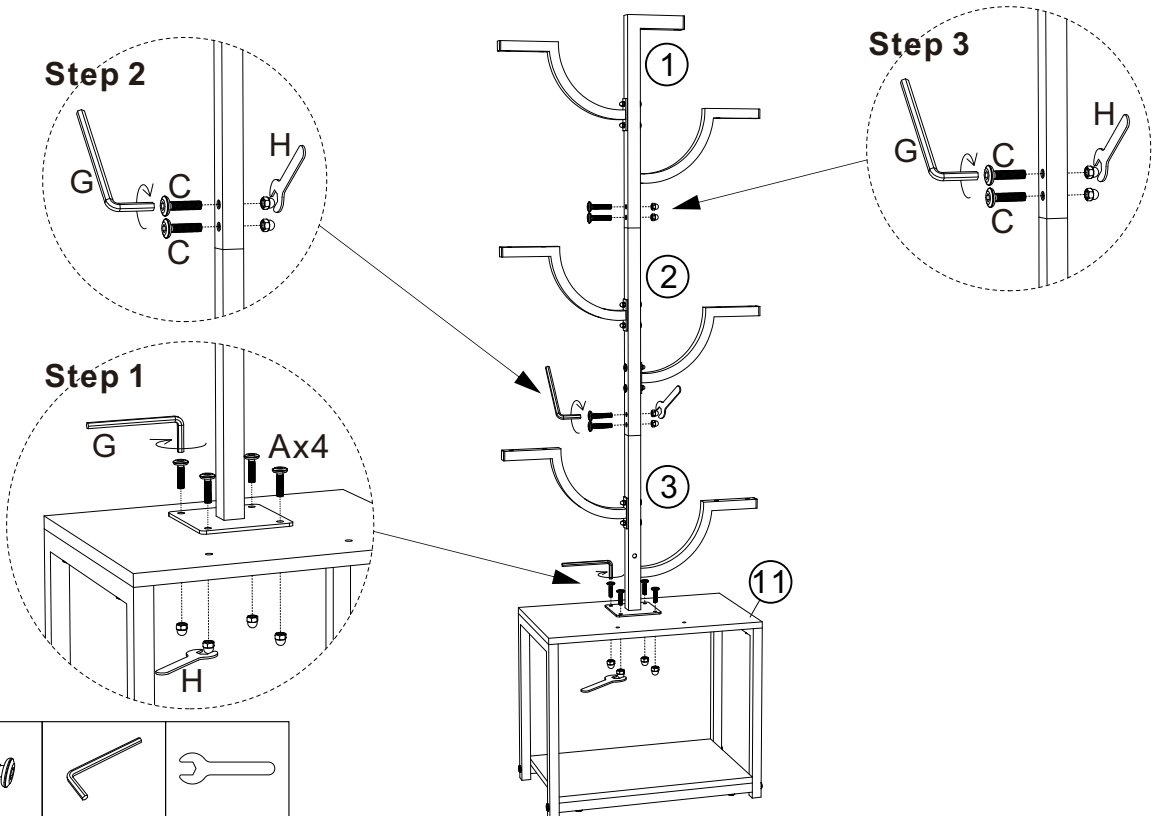

ASSEMBLY INSTRUCTIONS

5 Connect support frame (3) and connection rod (7) by screw (D).

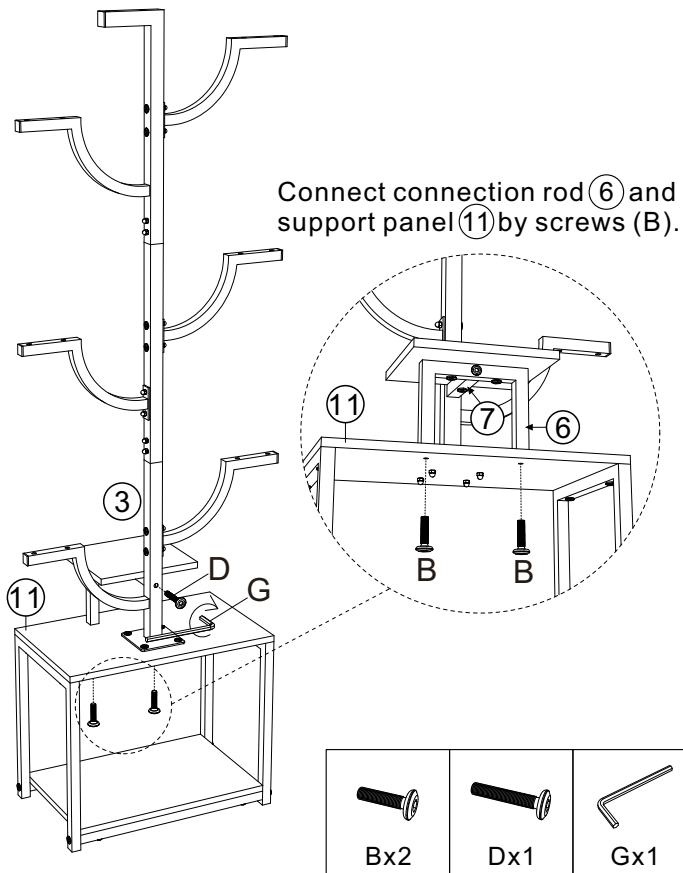

6 Use screws (B) and screws (D) to fix support panels (9) to support frame (1) (2) (3).

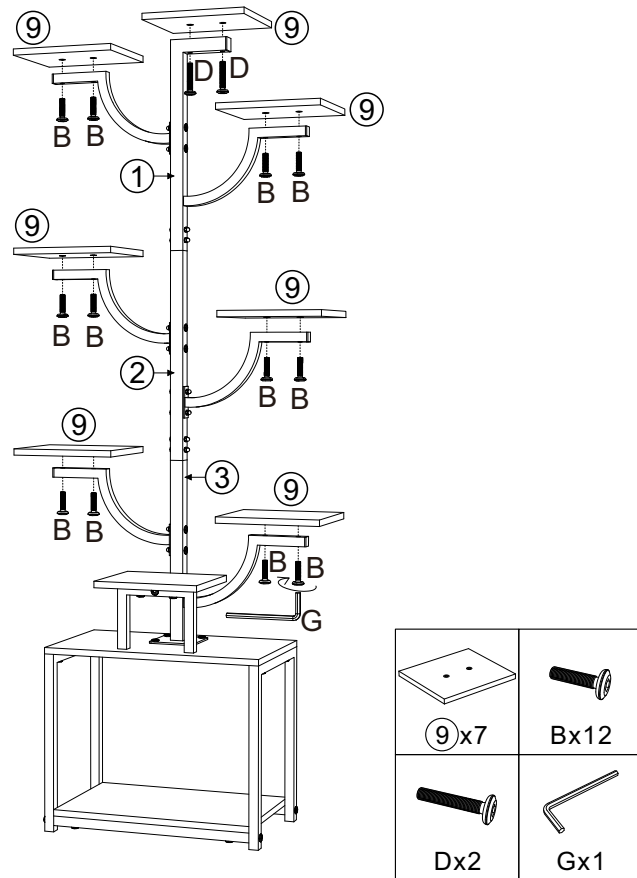

7 Connect connection rods (4) by caster wheels (13).

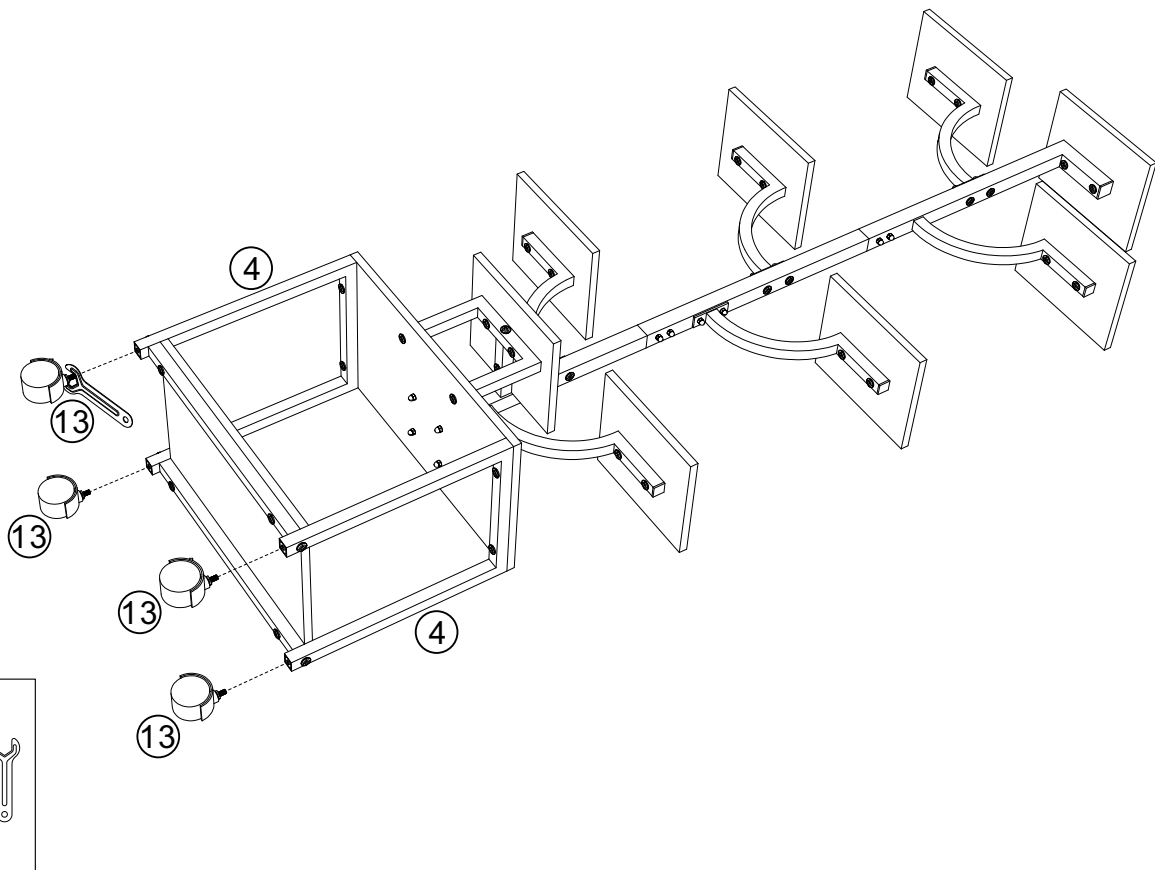

ASSEMBLY INSTRUCTIONS

8

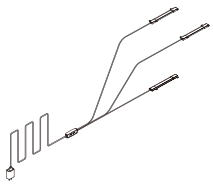
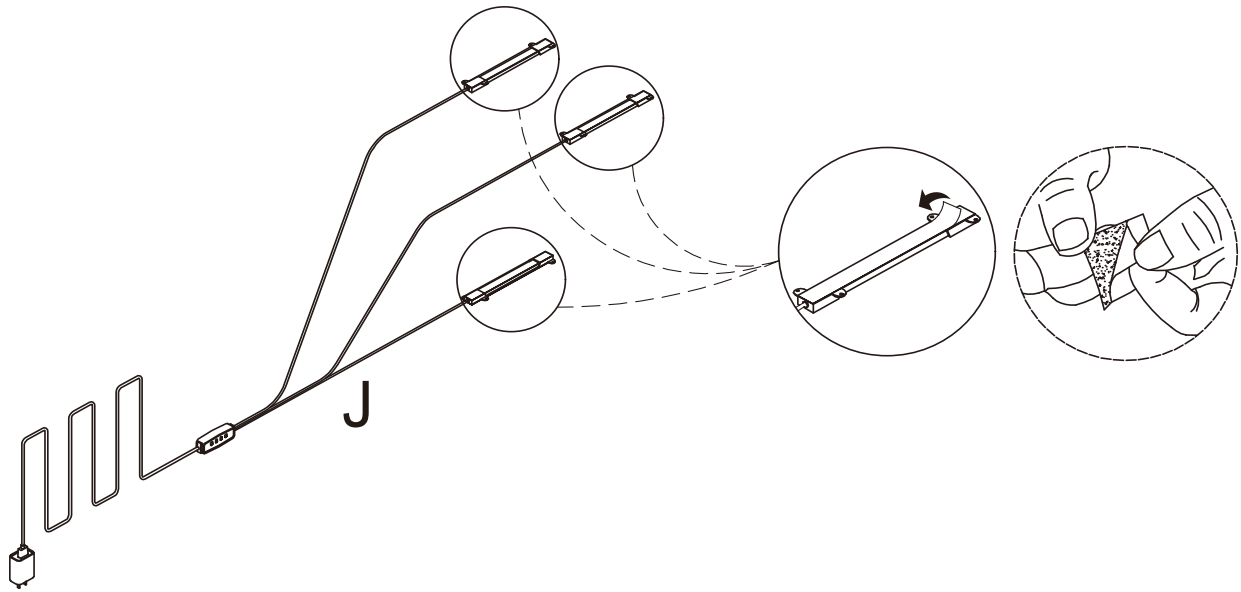

Jx1

9

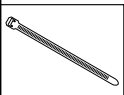
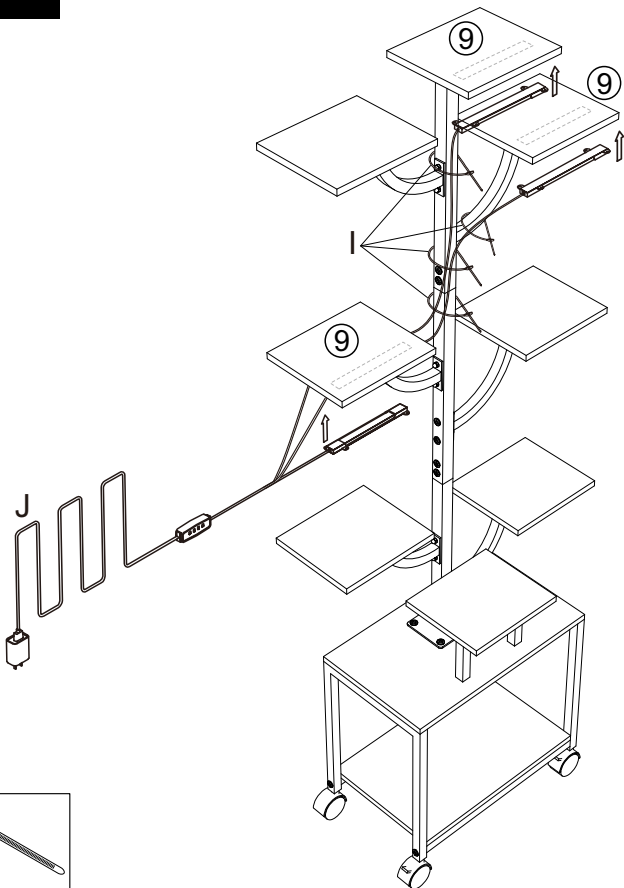

Ix4

10

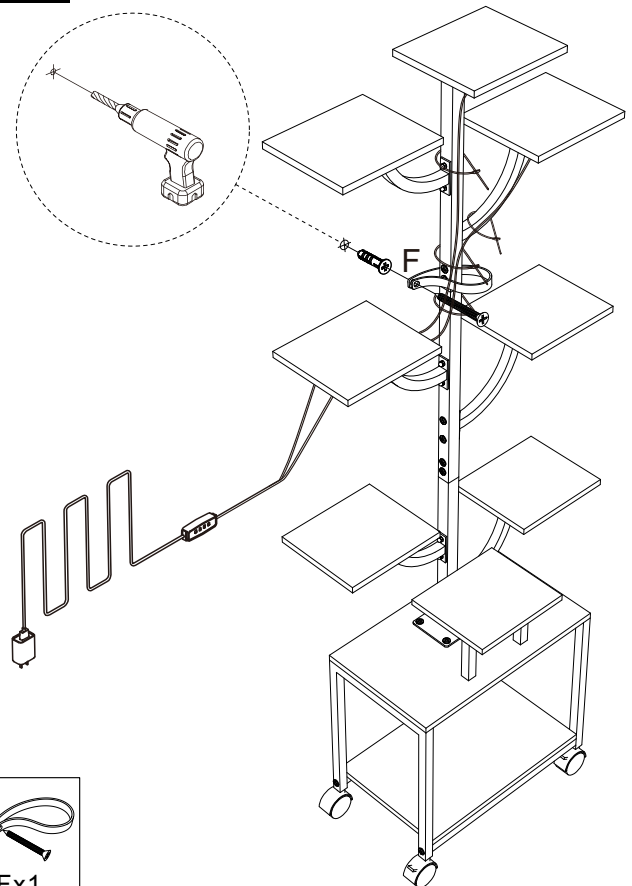

Fx1