

FULL/QUEEN BED ASSEMBLY INSTRUCTIONS

BOX #1

- A. HEADBOARD 1 PC
- B. RIGHT LEG 1 PC
- C. LEFT LEG 1 PC
- D. STRETCHER 1 PC

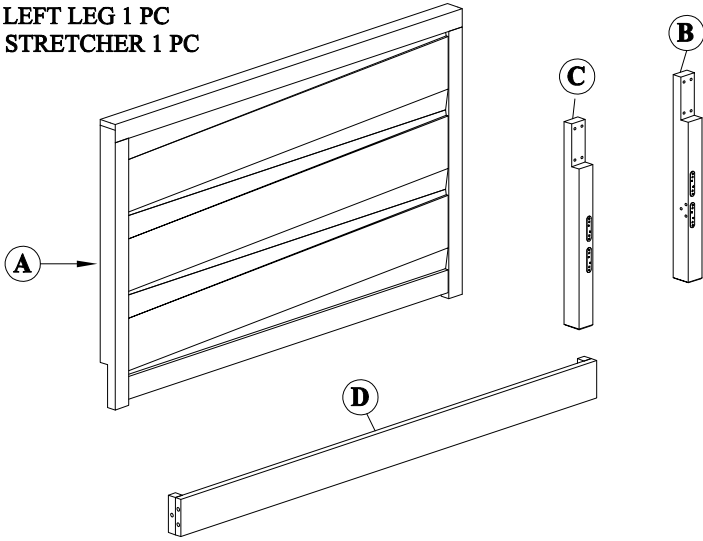

BOX #3

- F. FOOTBOARD 1 PC
- G. SLAT ROLL 1 SET
- H. SLAT SUPPORT 5 PCS

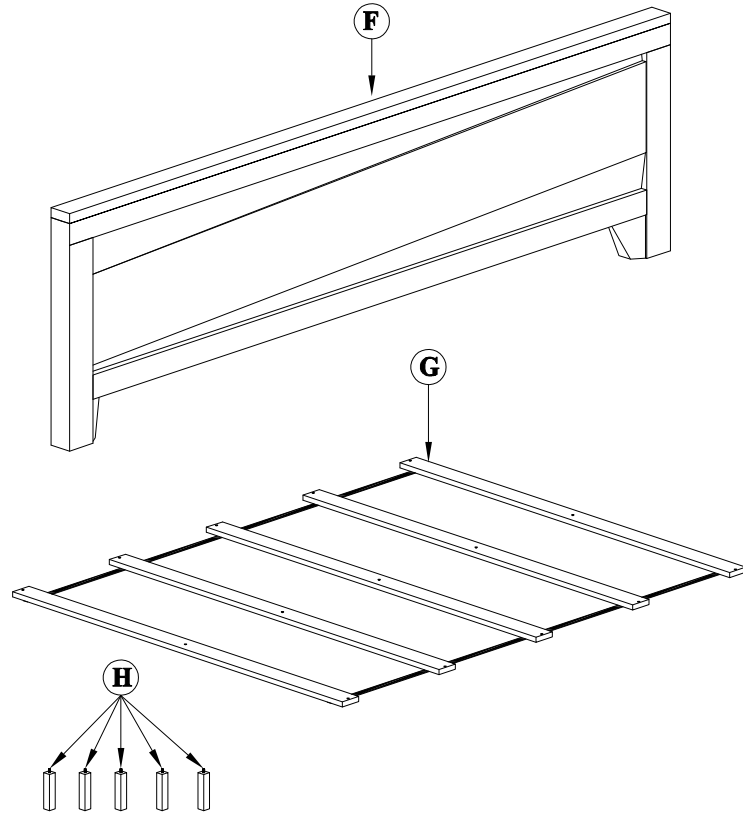

BOX #2



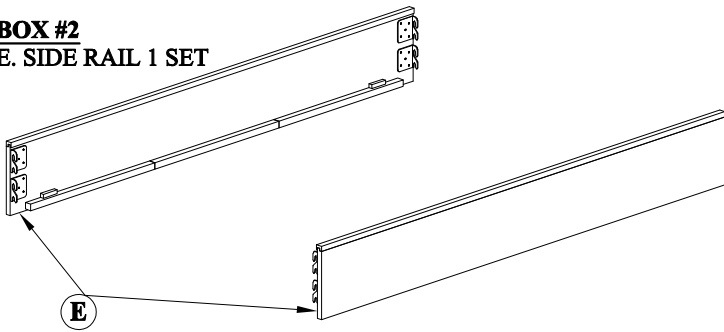



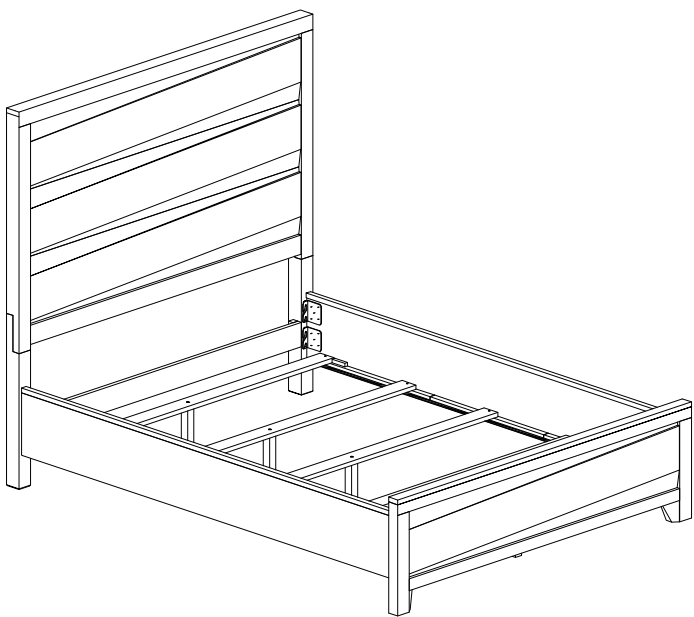

- E. SIDE RAIL 1 SET



FULL/QUEEN BED FULLY ASSEMBLED



HARDWARE PACKED IN BOX # 3

1	ALLEN BOLT (M8x60)		8 PCS
2	ALLEN BOLT (M8x50)		2 PCS
3	ALLEN BOLT (M8x30)		16 PCS
4	LOCK WASHER (M9)		10 PCS
5	FLAT WASHER (M8)		26 PCS
6	SCREW (M4x30)		10 PCS
7	ALLEN KEY		1 PC
8	WOOD DOWEL (8x30)		4 PCS

TOOL REQUIRED
PHILLIPS HEAD SCREW DRIVER NOT PROVIDED

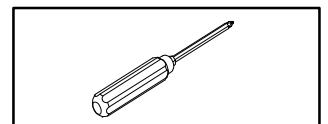

FULL/QUEEN BED ASSEMBLY INSTRUCTIONS

STEP 1

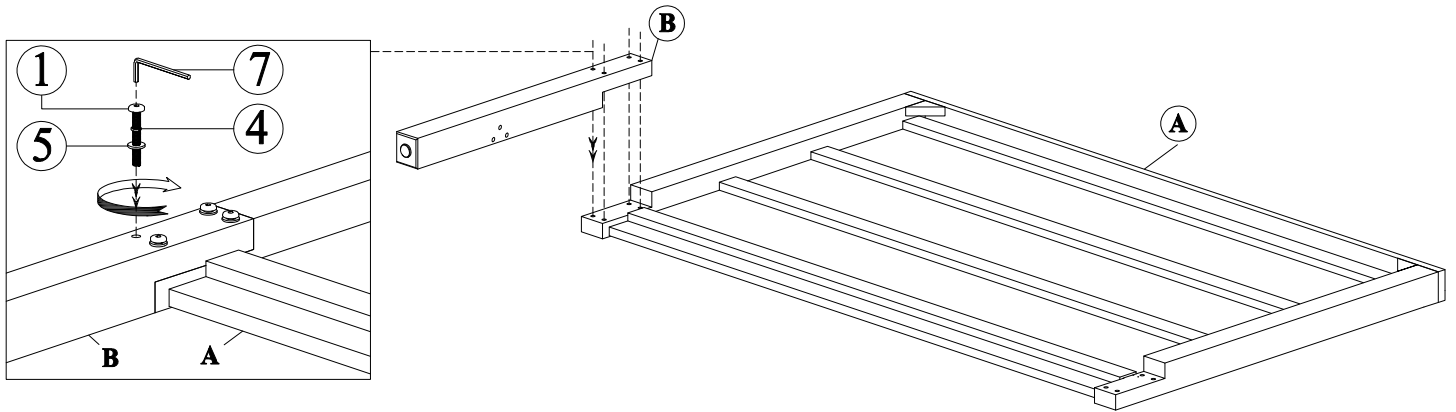

STEP 2

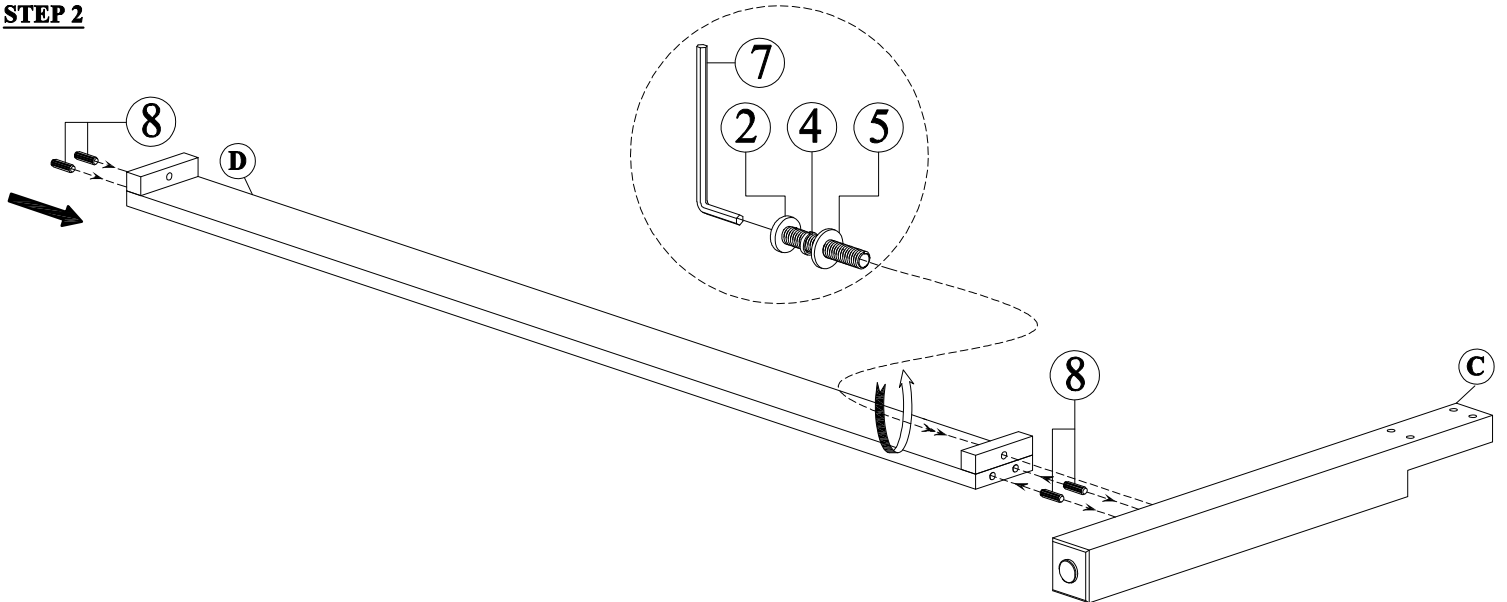

STEP 3

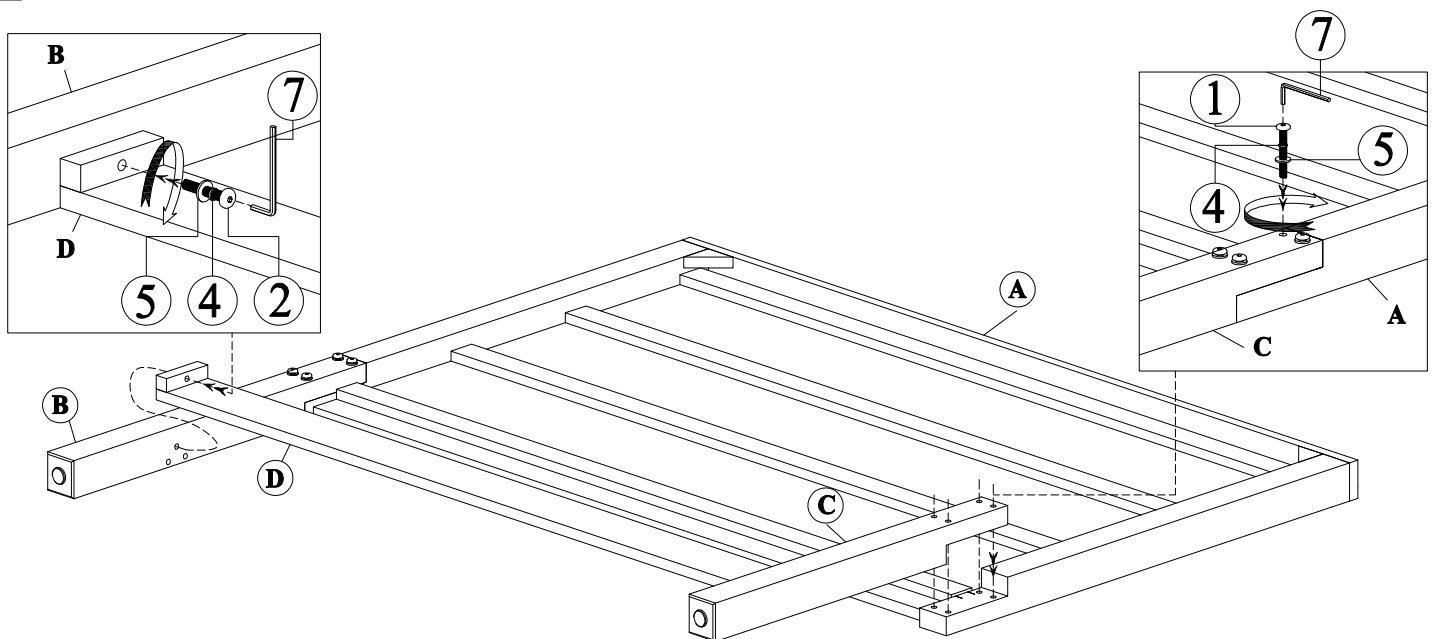

FULL/QUEEN BED ASSEMBLY INSTRUCTIONS

STEP 4

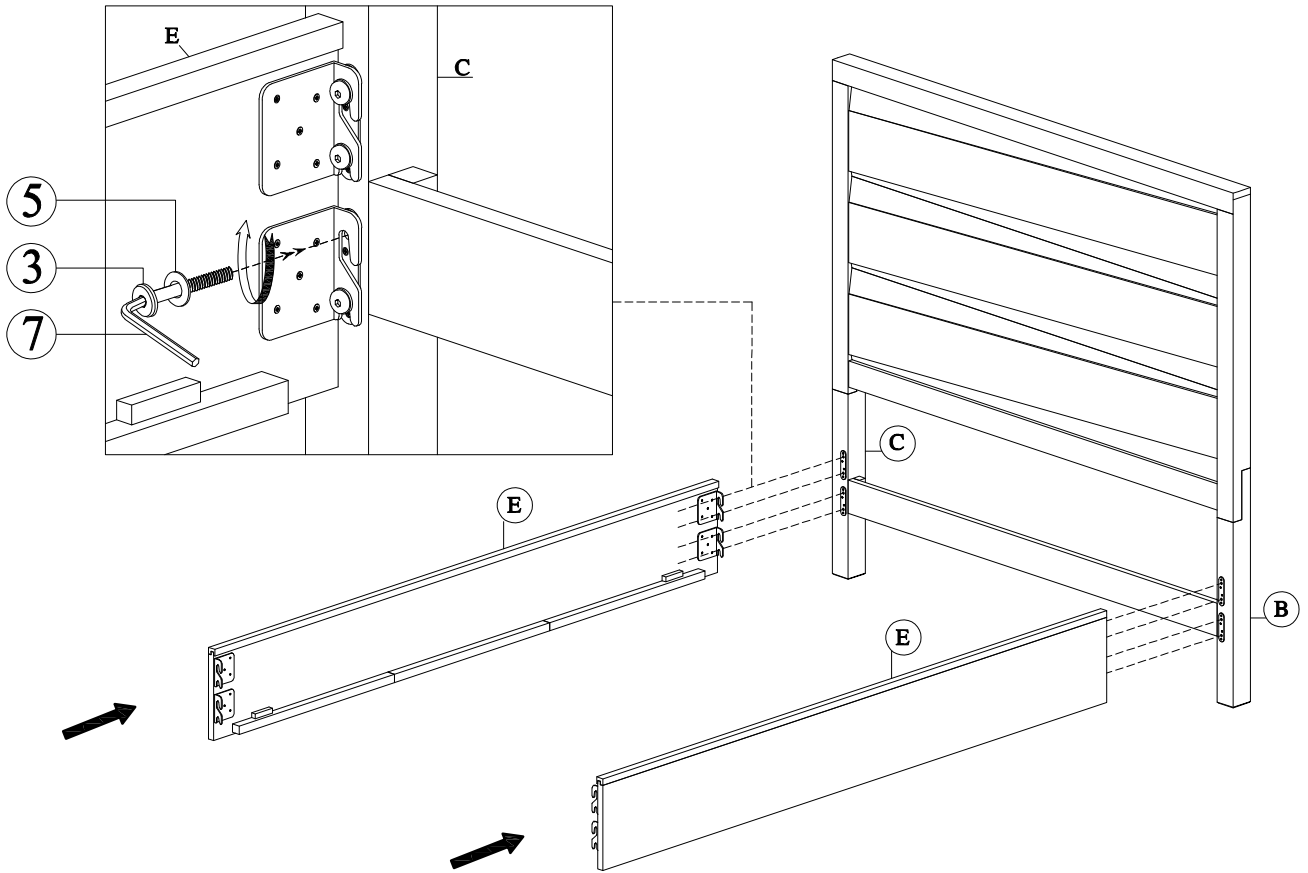

STEP 5

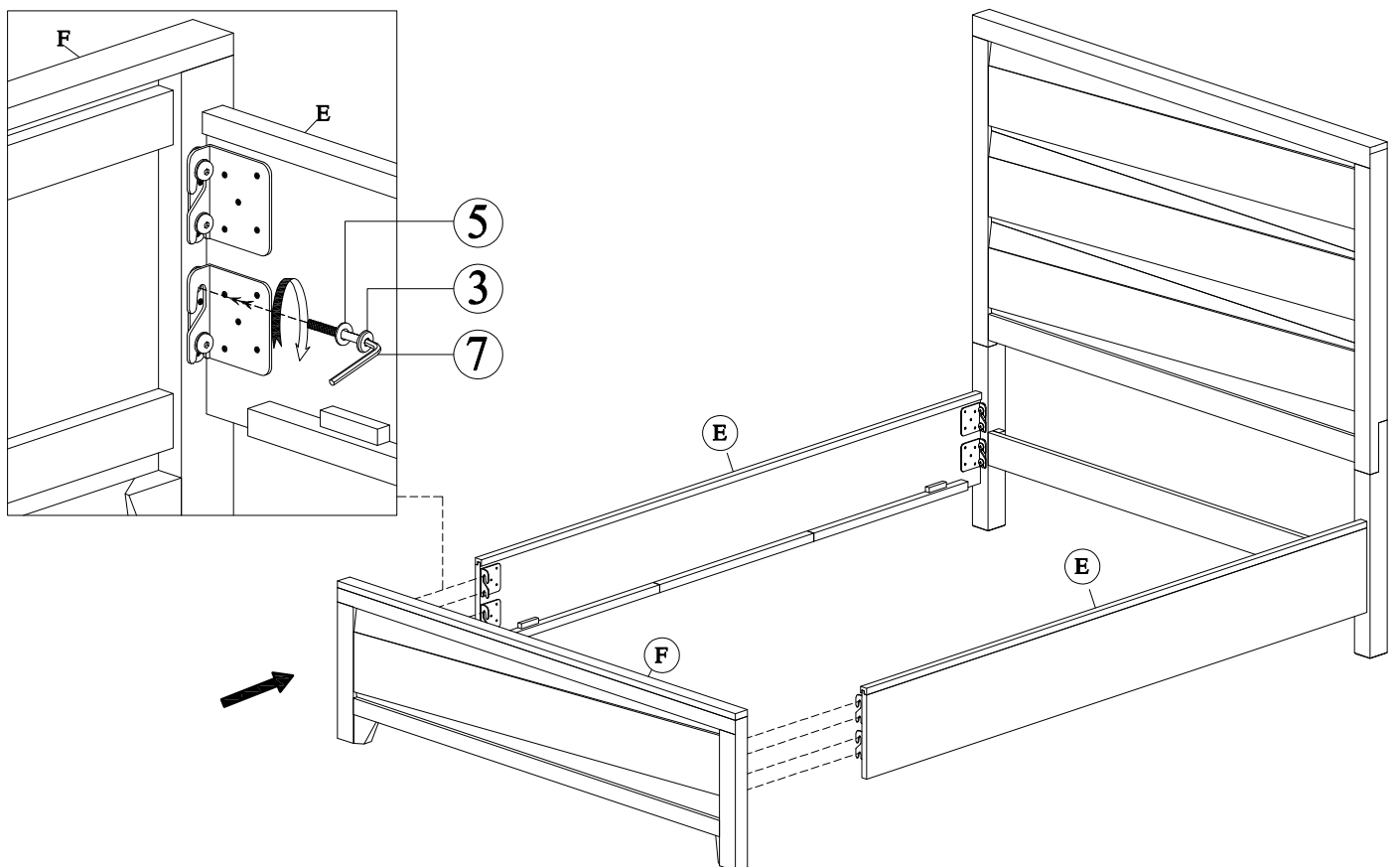

FULL/QUEEN BED ASSEMBLY INSTRUCTIONS

STEP 6

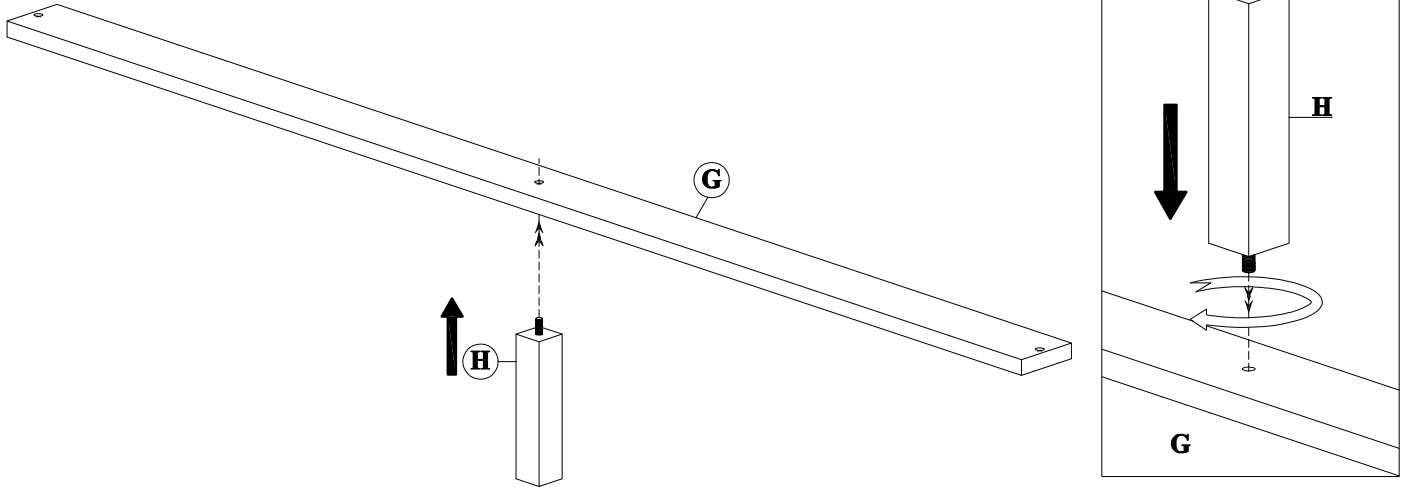

STEP 7

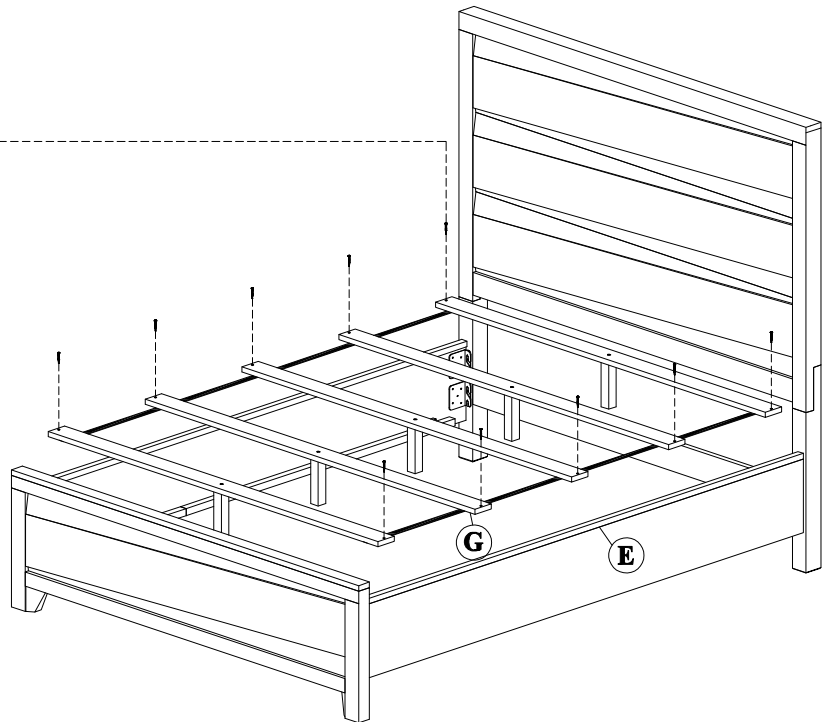
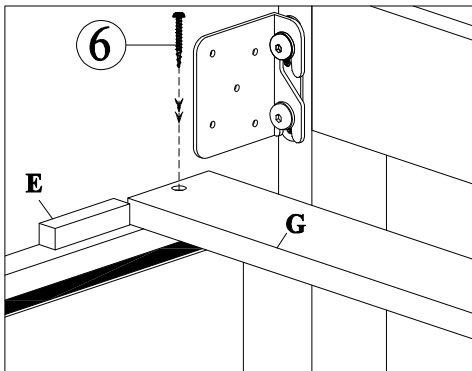

INSTRUCTIONS FOR ADJUSTING LEVELERS:

Position the bed in your room.
Locate levelers under each leg support.

Turn counter-clockwise to extend,
clockwise to contract.

Adjust levelers until each leg support is
applying equal upward pressure on the
bed slat.

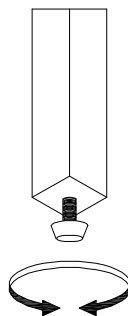

MAINTENANCE INSTRUCTION:

- Remove box spring and mattress before moving your bed
- Lift your bed when moving it.
Dragging can damage leg support.
- Readjust levelers after moving your bed.