

EC111-B - 32 X 18 TUB CART - THREE SHELVES

Product Specifications:

Item Number	EC111-B
Material	Injection Molded Thermoplastic Resin Legs: Polyvinyl Chloride (PVC) Shelves: High Density Polyethylene (HDPE)
Color Options	Black, Gray, Blue
Cart Dimensions	35.25" W x 18" D x 36.25" H
Weight	29 lbs.
Shelf Quantity	3
Shelf Dimensions	32.25" W x 18" D
Shelf Depth	2.5"
Distance Between Shelves	10.5"
Casters (4)	4" full swivel; two casters include locking brakes
Weight Capacity	400 lbs.
Made in USA	Yes
Shipping Method	Freight
Shipping Carton Dims	1 carton; 36" W x 19" D x 13" H
Shipping Weight	29 lbs.
Assembly Required	Yes

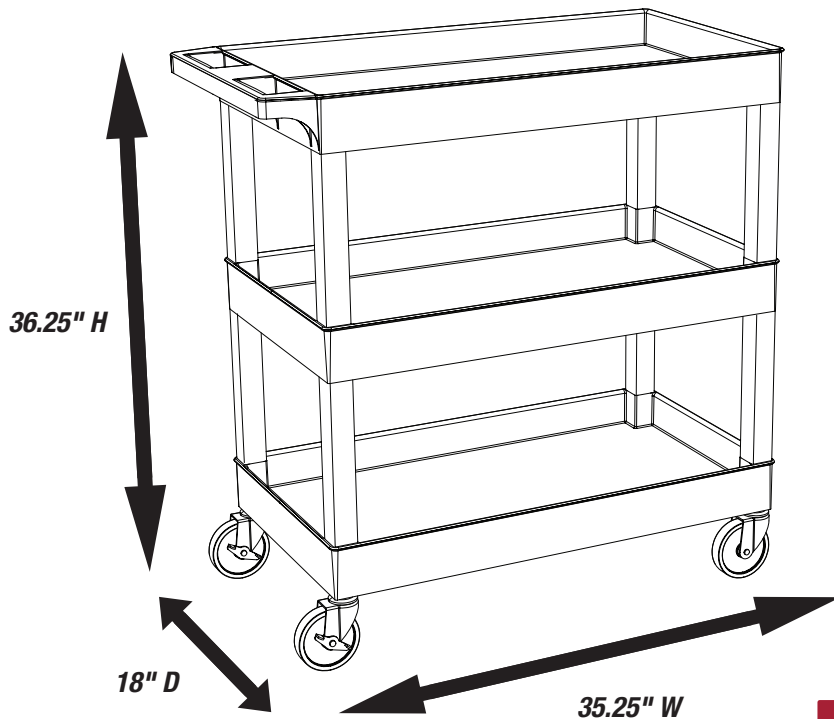

To Order, Call Your
Sales Representative
or 800-323-4656