

ASSEMBLY INSTRUCTIONS

ASSEMBLY TIPS:

1. Remove hardware from box and sort by size.
2. Please check to see that all hardware and parts are present prior to start of assembly.
3. Please follow attached instructions in the same sequence as numbered to assure fast & easy assembly.









Warning !



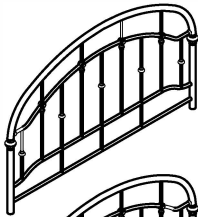
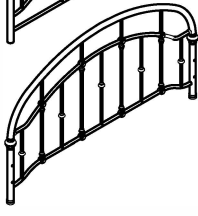

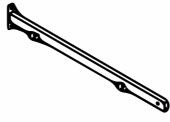



1. Don't attempt to repair or modify parts that are broken or defective . Please contact the store immediately.
2. This product is for home use only and not intended for commercial establishment.

PARTS IDENTIFICATION

Z

HARDWARE PACKAGE



A		1PC
B		1PC
C		1PC
D		2PCS
E		2PCS
F		2PCS
G		2PCS
H		2PCS
I		6PCS

NO	DESCRIPTION	FIGURE	QTY
1	BOLT 1/4"x2"		6PCS
2	BOLT 1/4"x5/8"		16PCS
3	BOLT 1/4"x7/8"		4PCS
4	BOLT 1/4"x1-3/4"		6PCS
5	METAL WASHER		30PCS
6	HEX. NUT		4PCS
7	ALLEN WRENCH		1PC
8	OPEN END WRENCH		1PC

ASSEMBLY



Do not fully tighten all bolts until assembly is complete. This will help all parts to assemble properly.

Step 1: Align and attach the leg (D) to the headboard (A) using the bolt(2), washer(5), tighten with allen wrench. As shown on the drawing.

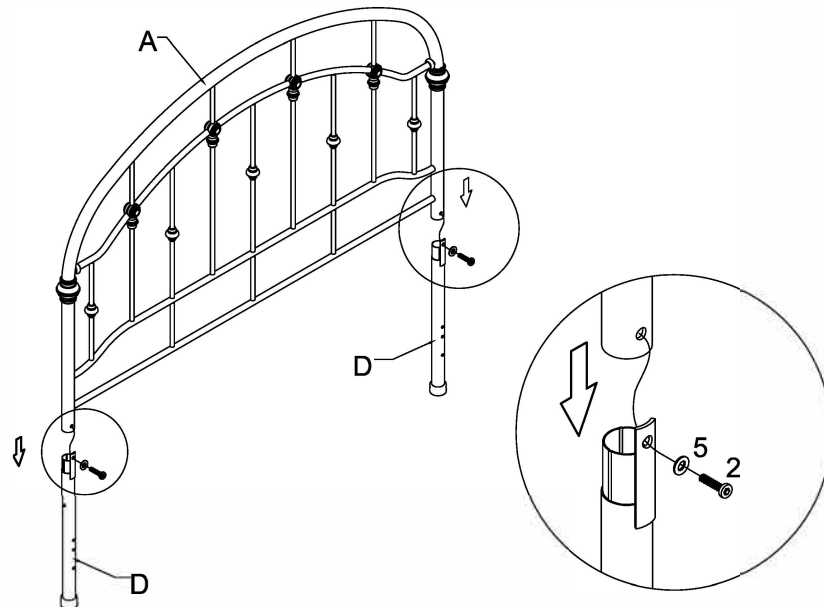
2		2PCS
5		2PCS
7		



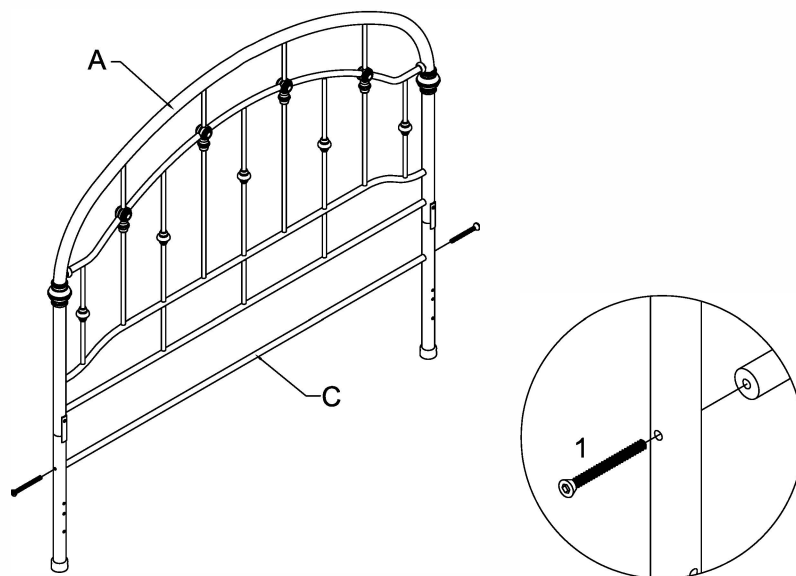

Step 2: Align and attach the cross bar (C) to the headboard (A) using the bolt (1), tighten with allen wrench. As shown on the drawing.

1		2PCS
7		







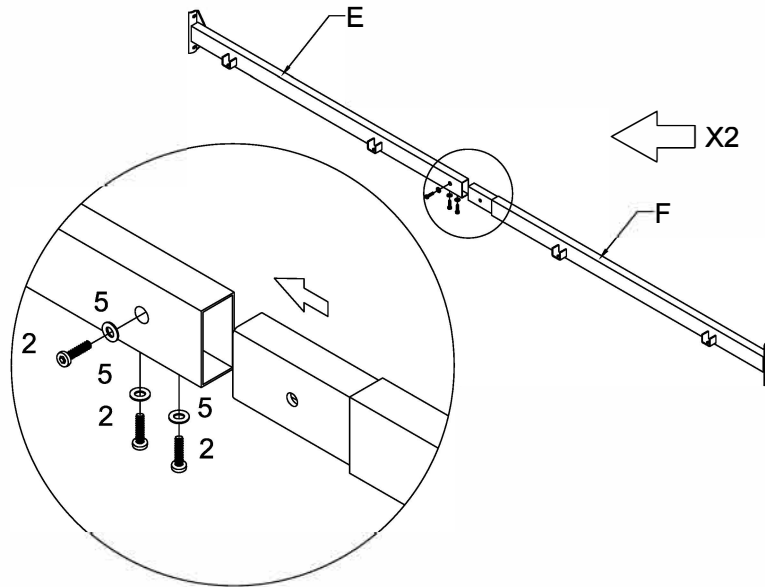

Step 3: Align and attach the side rail 1 (E) and the side rail 2 (F) using the bolt (2), washer (5), tighten with allen wrench. As shown on the drawing.

2		6PCS
5		6PCS
7		



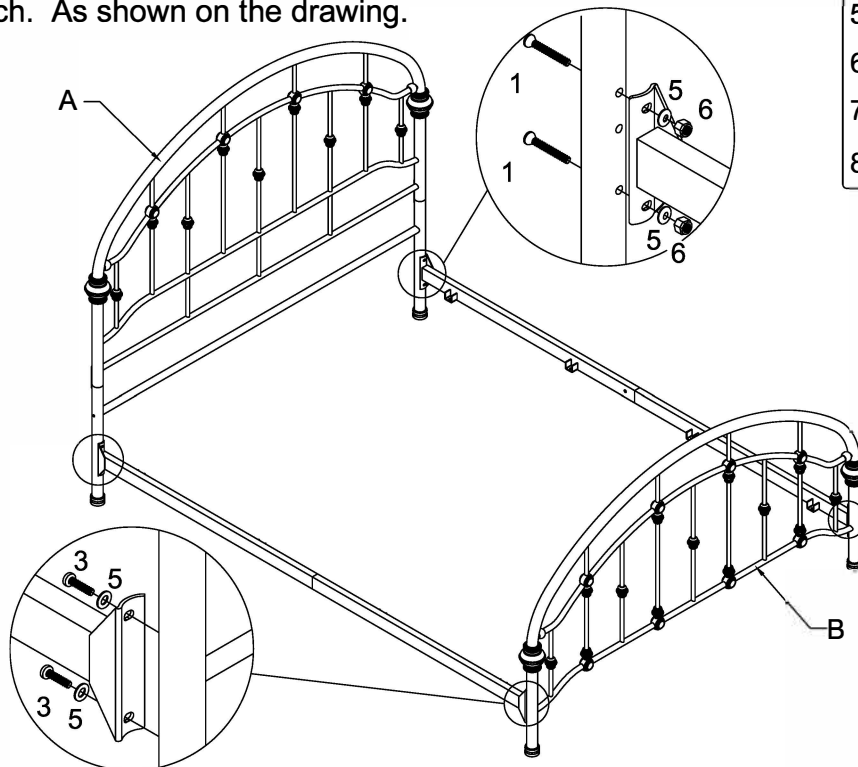

Step 4: Align and attach the side rail to the headboard (A) using the bolt (1), washer (5), nut (6), tighten with allen wrench. attach the side rail to the footboard (B) using the bolt (3), washer (5), tighten with allen wrench. As shown on the drawing.

1		4PCS
3		4PCS
5		8PCS
6		4PCS
7		
8		



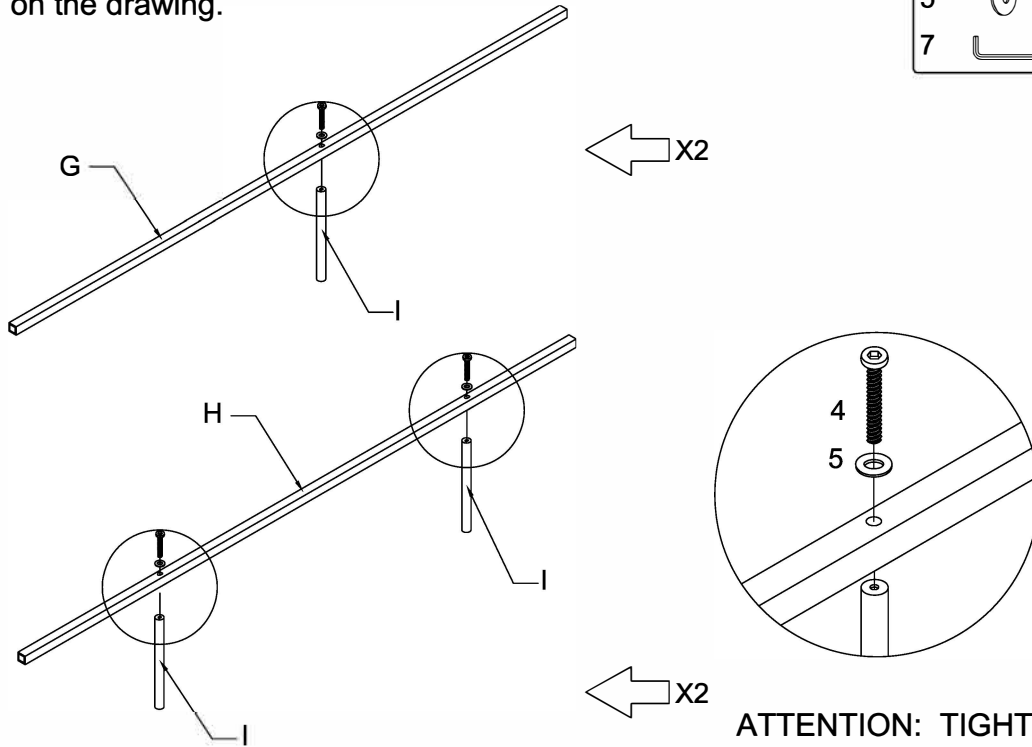

Step 5: Align and attach the support leg (I) to the slat (G) & (H) using the bolt (4), washer (5), tighten with allen wrench. As shown on the drawing.

4		6PCS
5		6PCS
7		



ATTENTION: TIGHTEN ALL THE BOLTS AT THIS STEP.

Step 6: Align the assembled slats to side rails using the bolt (2), washer (5), tighten with allen wrench, then completed. As shown on the drawing.

2		8PCS
5		8PCS
7	