

Hi,

Thank you for choosing ACACIA! We hope you're enjoying your new purchase.

We would be grateful if you could share your experience with other customers by leaving a review. Your feedback helps us improve our products and services.

Your satisfaction is our top priority. If you have any questions or need assistance, please don't hesitate to contact us.

-  [facebook.com/acaciawoodfurniture](https://facebook.com/acaciawoodfurniture)
-  [pinterest.com/acaciawoodfurniture/](https://pinterest.com/acaciawoodfurniture/)
-  [instagram.com/acacia.woodfurniture/](https://instagram.com/acacia.woodfurniture/)
-  <https://aciaciavn.com/pages/faqs>

Thank you for purchasing this quality product. Be sure to check all packing material carefully for small parts which may have come loose inside the carton during shipment. Identify and count all parts and compare with the parts list below.

ACACIA  
ELARA  
DRESSER



Read all assembly and care instructions carefully before using this product. Save these instructions for future reference.



- Select a smooth, level surface to place the dresser.
- Assemble components on a soft, clean surface to avoid scratching and/or damaging the finish.
- Ensure all parts are accounted for before disposing of packaging.
- Using incompatible hardware might cause damages to product.
- This package contains small parts. Keep away from children prior and during assembly. Adult assembly is required.

## ASSEMBLY

### HARDWARE LIST

A		Bolt M6x30	6
B		Bolt M6x15	4
C		Angle Bracket	4
D		Screw M4x15	22
E		Camlock M6x30	24
F		Screw M7x40	26
G		Allen Key M4	1
H		Handle	5
I		Angle bracket	2
J		Screw M4x40	4

### ANTI-TIP-PARTS

(A)		Bracket	4
(B)		M4 x 20 screw	4
(C)		M8 x 51 Plug	4
(D)		M6 x 70 screw	4
(E)		Strap	2

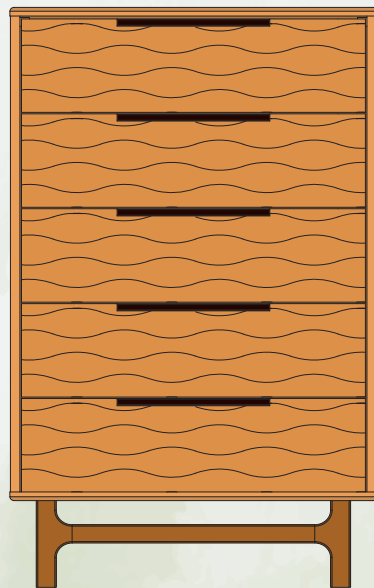

## IMPORTANT INFORMATION

Under normal use, Elara Dresser will last for years. It is, however, important to follow basic care tips to prolong the life of your Dresser.

### USE & CARE

- Clean the product with mild cleanser using soft damp cloth.
- Do not use harsh or abrasive cleansers.
- Alter the finish might damage the integrity of the product.
- Avoid dragging sharp or rough objects across the surface.
- Avoid direct sunlight exposure.
- Do not place near heating units or vents.
- Promptly wipe up any spills or any other moisture.
- This dresser requires the weight panel to be installed for proper stability.
- DO NOT use the dresser without the weight panel attached.
- Improper installation may lead to tipping hazards and potential injuries.
- Always follow the assembly instructions to secure the weight panel correctly.

### TROUBLESHOOTING

If the Dresser seems unstable, make sure it is on a level surface and the feet are correctly distributed as shown in the assembly instructions. Also make sure that all components are assembled correctly and the hardware is securely tightened.

**Any modification or failure to follow the recommended care will void the product warranty.**

## WARRANTY INFORMATION

Thank you for choosing ACACIA. We stand behind our brand and the quality of the items we sell.

ACACIA is not responsible for normal wear and tear, for products used commercially or for failures caused by accidents, abuse, alteration, modification, misuse or improper care. There are no other express warranties beyond the terms of this limited warranty. In no event shall any implied warranties, including merchantability and fitness for a particular purpose, extend beyond the duration of the express warranty contained herein. In no event shall ACACIA be liable for incidental or consequential damages.

Elara Dresser is covered by 05-year limited warranty.

Replacement parts or products will be sent at our discretion if the defect is the result of any fault on our side. Proof of purchase, with the date of purchase as well as photos of the defective merchandise, must be provided. Photos are used to determine the cause of defects and for future quality control. Please contact ACACIA Customer Service directly; or if you have any questions, comments or concerns by emailing us at [customerservice@acaciavn.com](mailto:customerservice@acaciavn.com), or via our Contact Us page at [www.acaciavn.com/contact-us/](http://www.acaciavn.com/contact-us/)



### WARNING!

Manufacturer and seller expressly disclaim any and all liability from personal injury, property damage or loss, whether direct or indirect, or incidental, resulting from the incorrect attachment, improper use, inadequate maintenance, or neglect of this product, external influence, and force majeure.

**WARNING**

Children have died from furniture tipover. To reduce the risk of furniture tipover:

- ALWAYS install anti-tip device provided.
- NEVER put a TV on this product.
- NEVER allow children to stand, climb or hang on any drawers, doors, or shelves.
- NEVER open more than one drawer at a time.
- Place heaviest items in the lowest drawers.

*This is a permanent label. Do not remove!*

04-000129-07

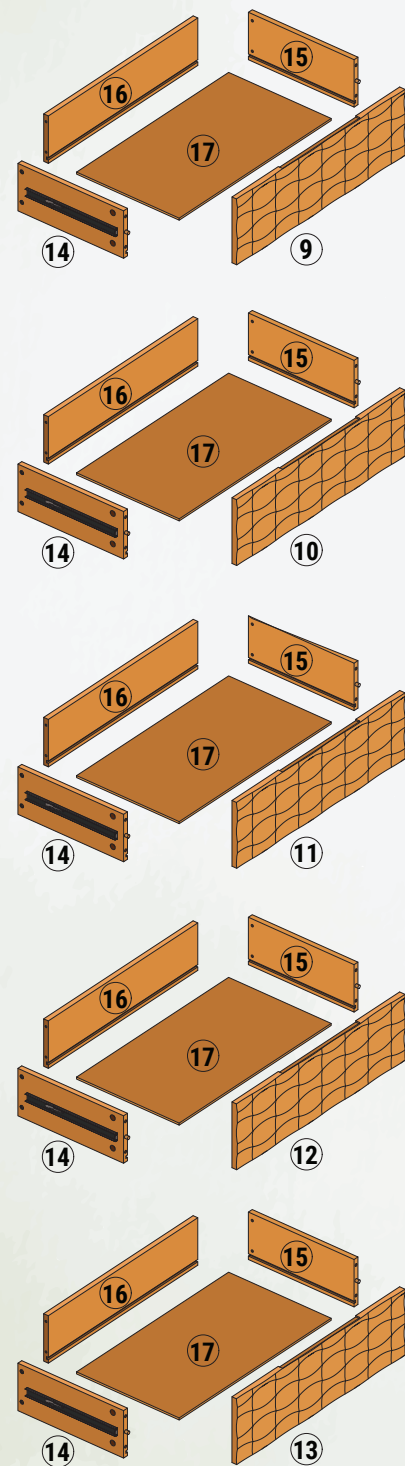
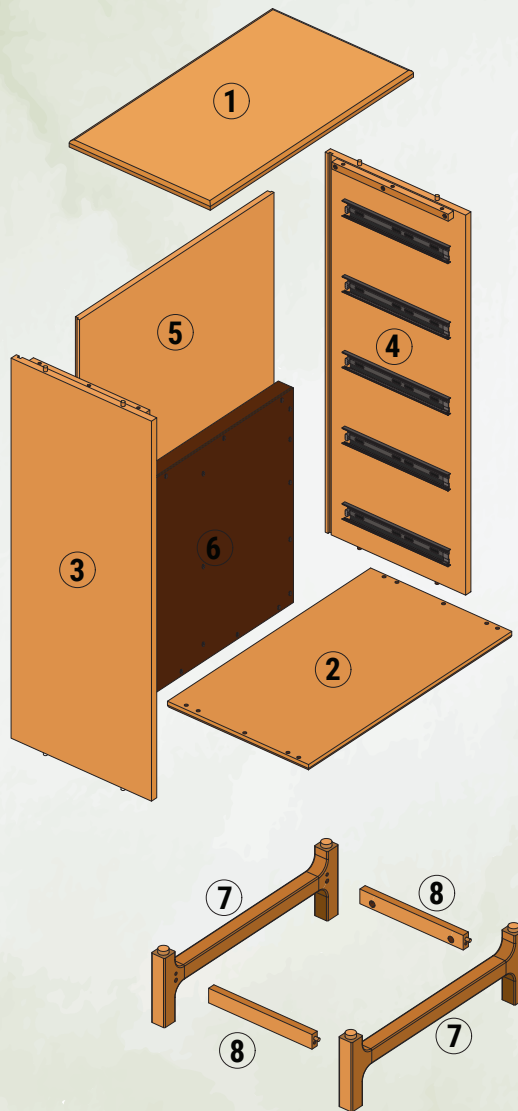
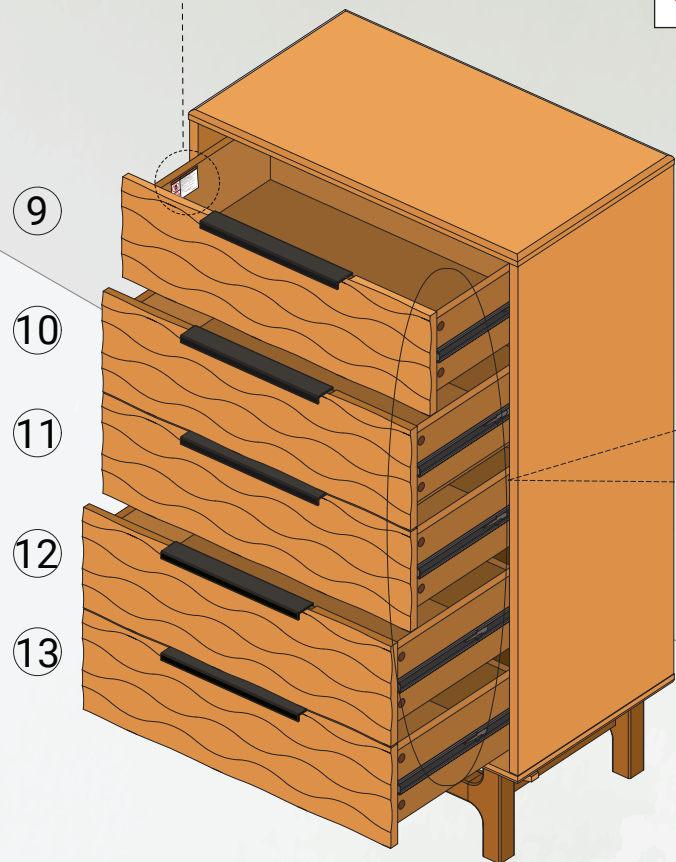

**1** \* Caution: Heavy product.  
Instructions that two persons are necessary to assemble  
respective piece of furniture.

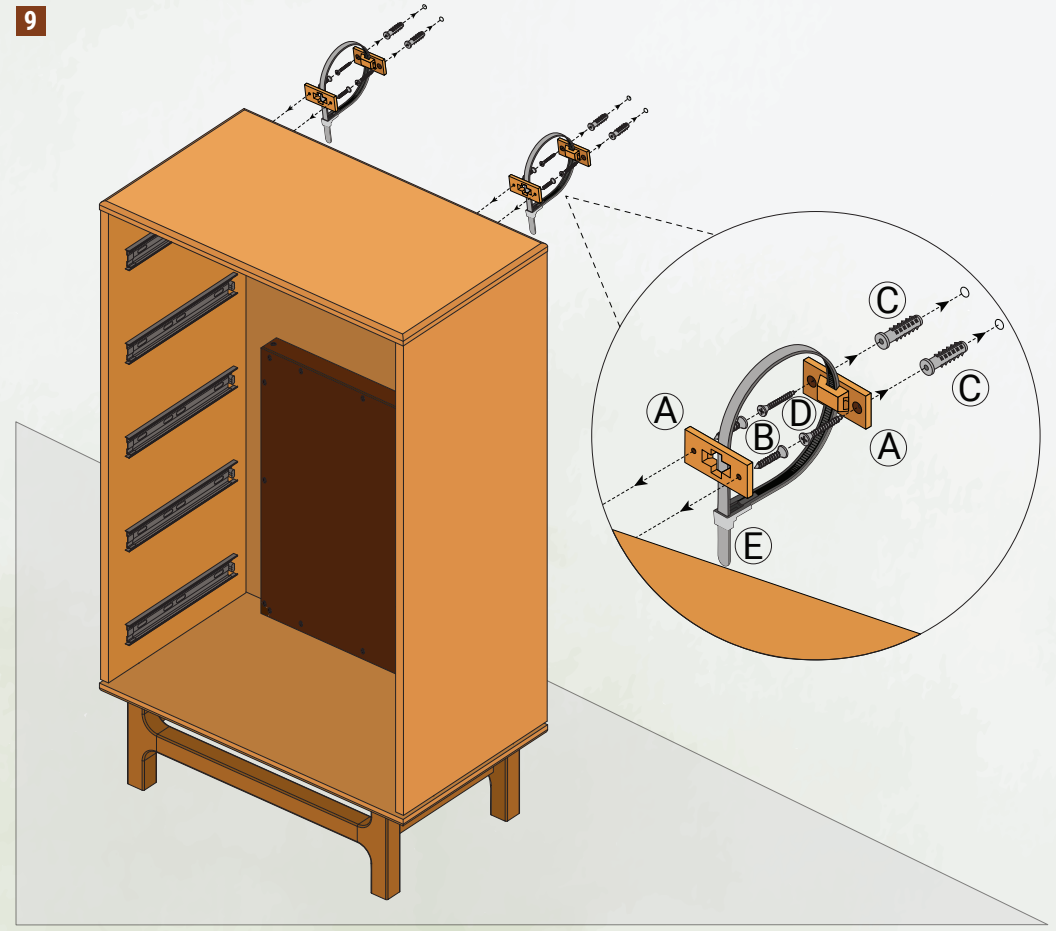
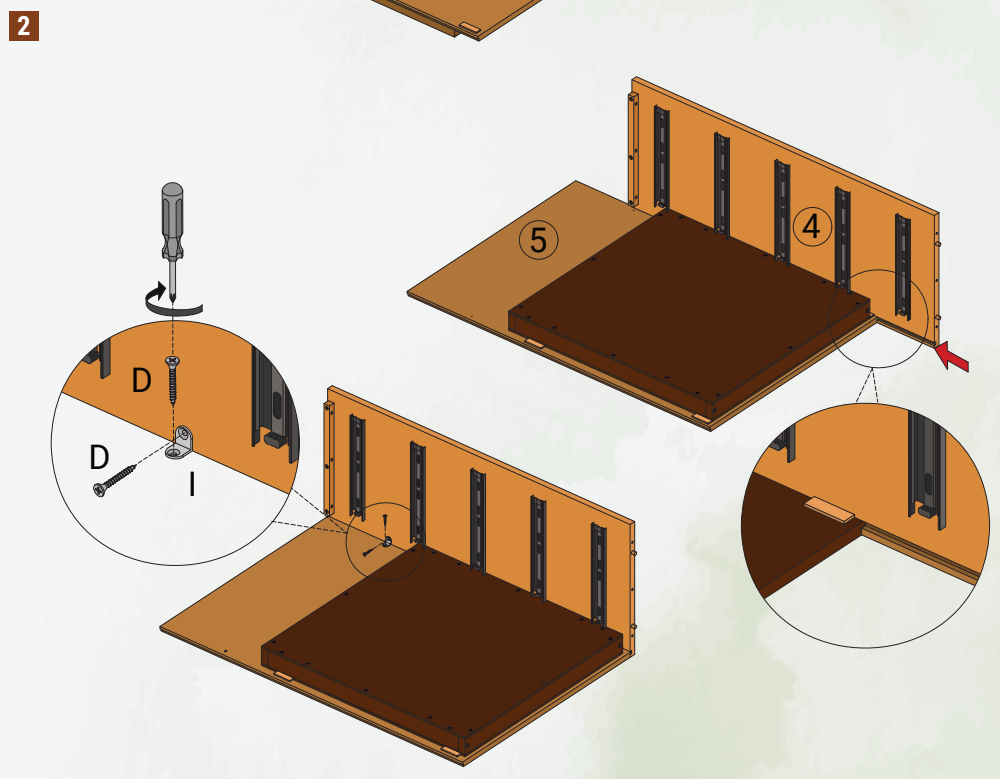
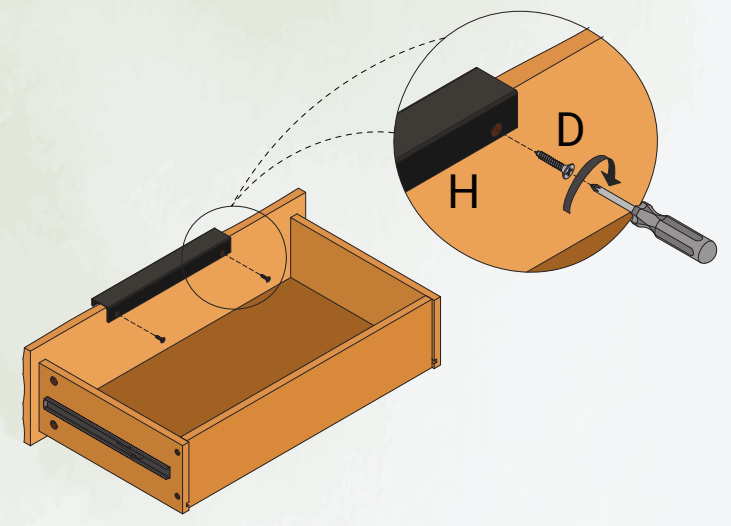
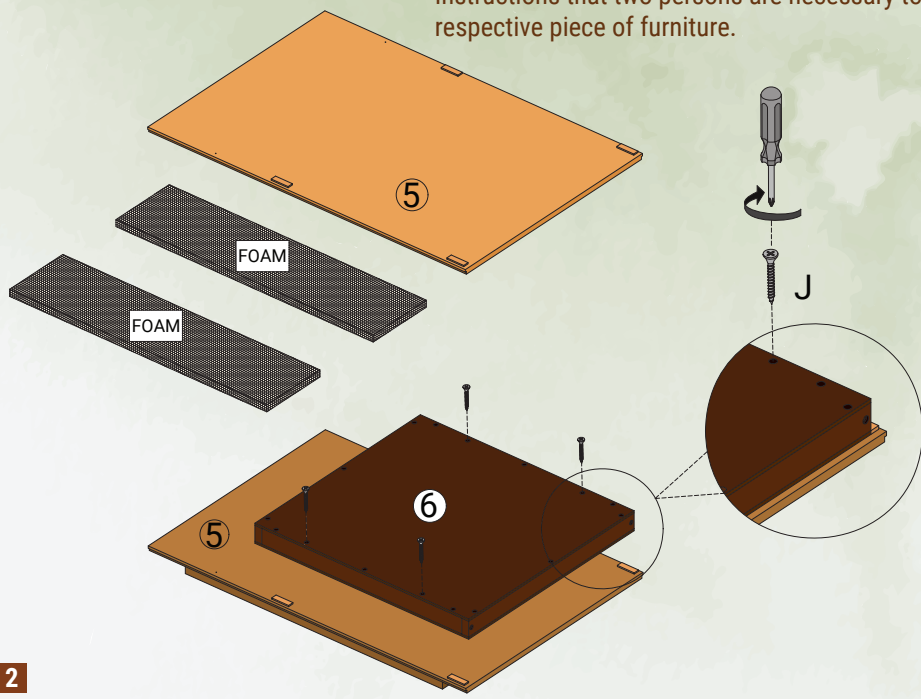

8

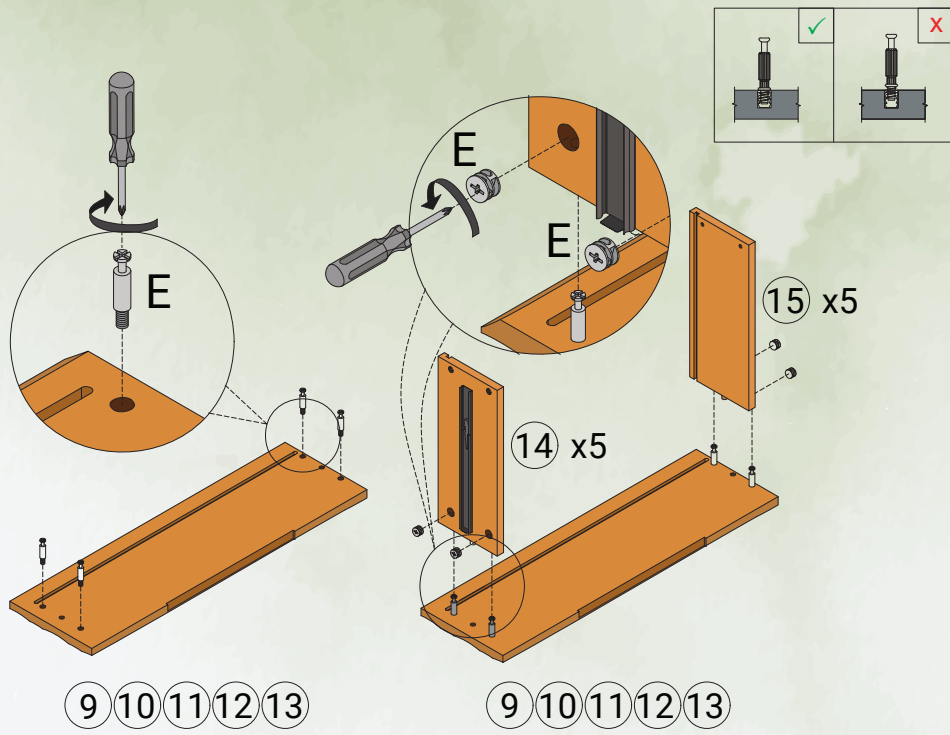

3

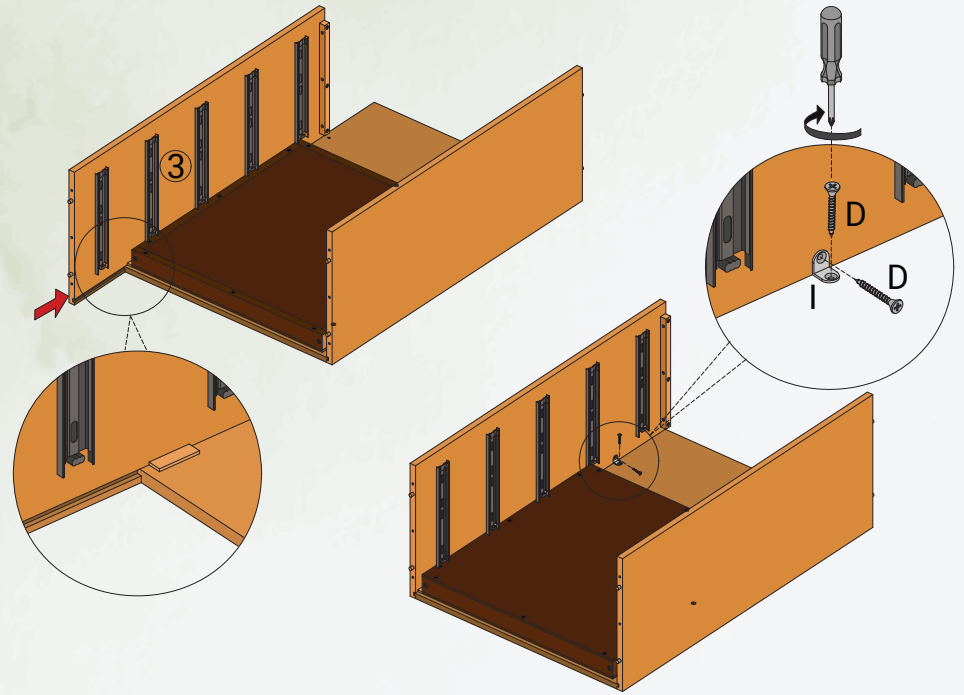

4

