

## ASSEMBLY INSTRUCTION

### ASSEMBLY TIPS:

- 1.Remove hardware from box and sort by size.
- 2.Please check to see that all hardware and parts are present prior to start of assembly.
- 3.Please follow attached instructions in the same sequence as numbered to assure fast & easy assembly.







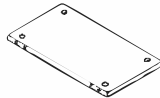
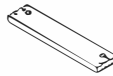
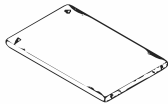
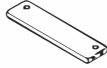
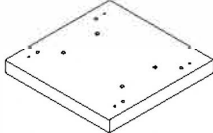
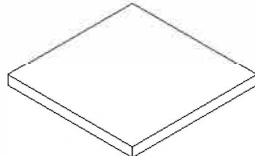

### Warning!

- 1.Don't attempt to repair or modify parts that are broken or defective.Please contact the store immediately.
- 2.This product is for home use only and not intended for commercial establishment.

**ASSEMBLY TIME PER UNIT: 30 MINUTES**

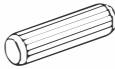
### PARTS IDENTIFICATION:

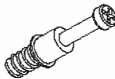
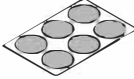
(A) SIDE PANEL		2 PCS	(D) LONG CROSS BRACE		2 PCS
(B) DIVIDER PANEL		2 PCS	(E) SHORT CROSS BRACE		2 PCS
(C) BOTTOM PANEL		1 PC	(F) TOP PANEL		1 PC

Z	HARDWARE PACKAGE						
NO	DESCRIPTION	FIGURE	Q'TY	NO	DESCRIPTION	FIGURE	Q'TY
1	GLUE 40g		1 PC	5	BOLT $\phi 9.5 \times 55 \text{mm}$		4 PCS
2	WOODEN DOWEL $\phi 8 \times 30 \text{mm}$		24 PCS	6	PLASTIC FEET $\phi 15 \text{mm}$		4 PCS
3	CAM BOLT $\phi 7 \times 35.5 \text{mm}$		20 PCS	7	STICKER $\phi 20 \text{mm}$		4 PCS
4	CAM LOCK $\phi 15 \times 12 \text{mm}$		20 PCS				

STEP 1 :

2  
x 16

3  
x 8

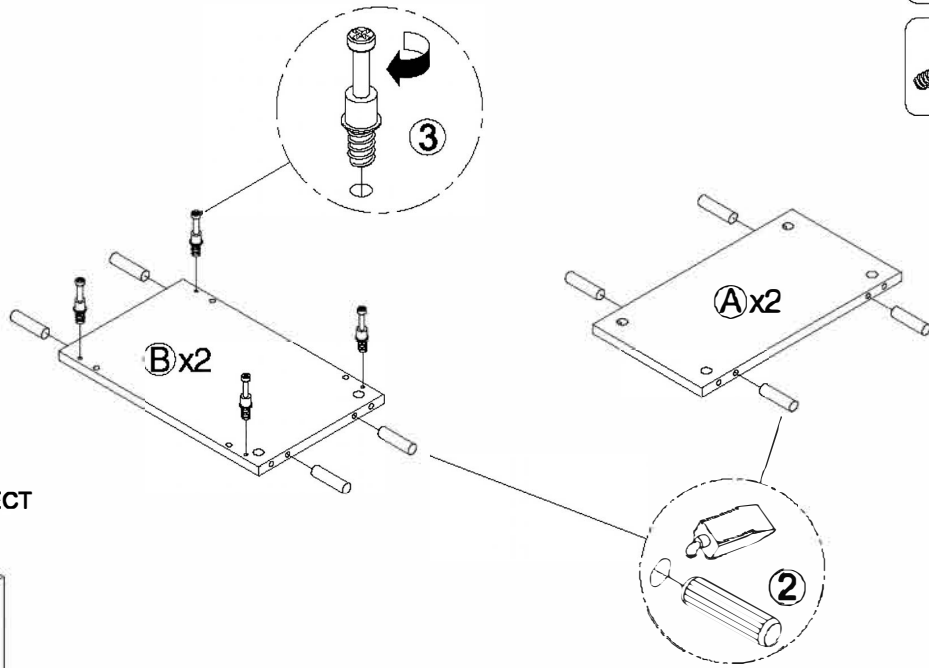

INCORRECT CORRECT

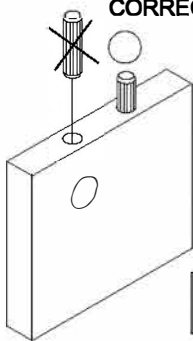

Apply glue on all wooden dowels to ensure integrity of the structure.

STEP 2 :

3  
x 8

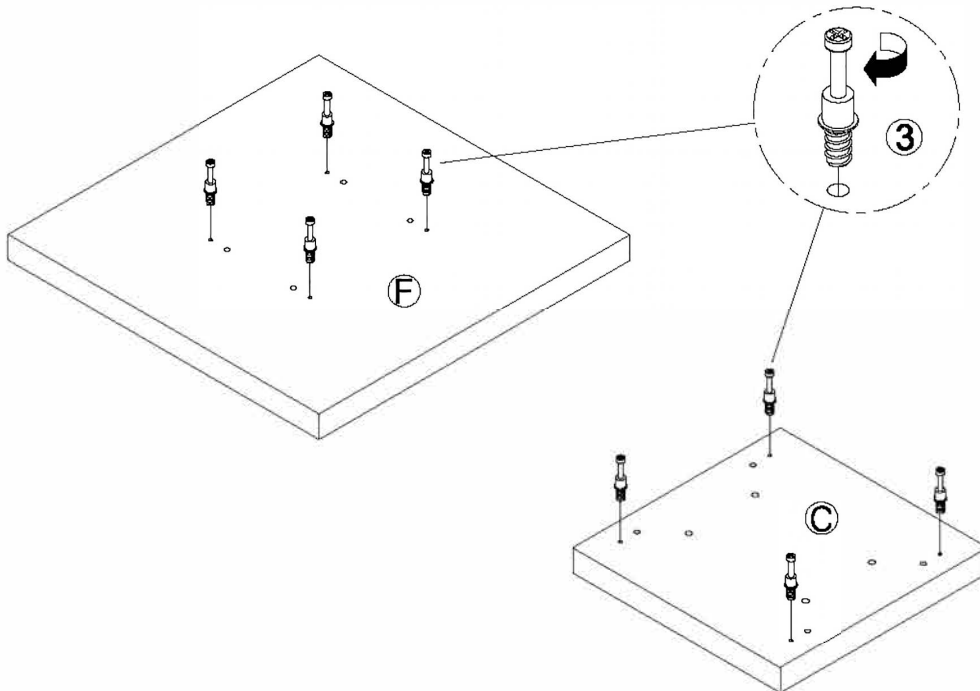

**STEP 3 :**

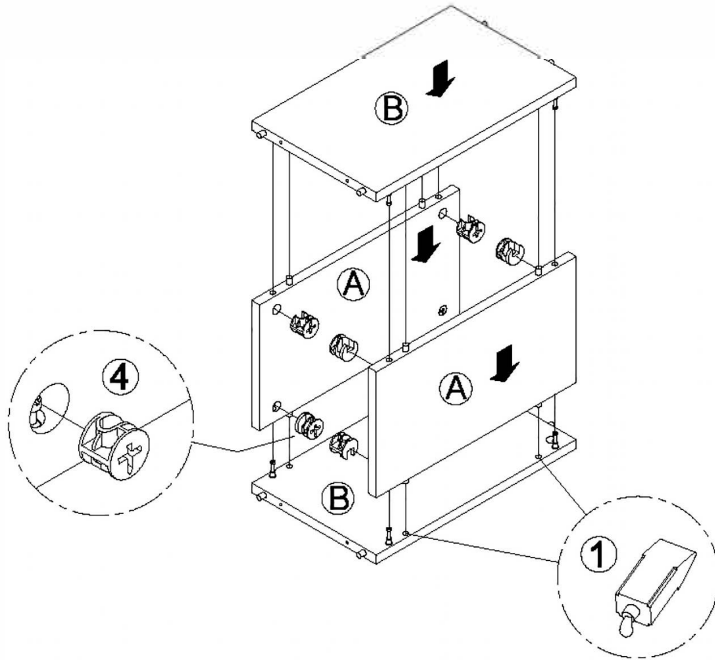
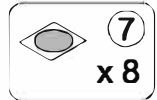
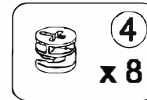

Apply glue on all wooden dowels to ensure integrity of the structure.

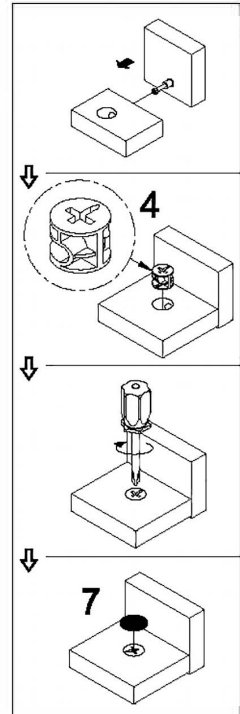

**STEP 4 :**

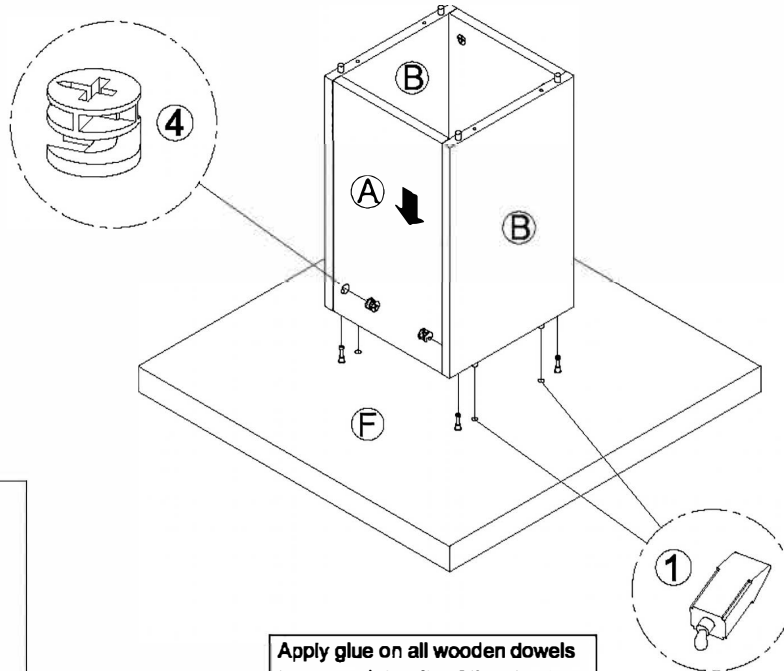
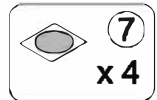
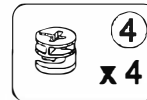

Apply glue on all wooden dowels to ensure integrity of the structure.

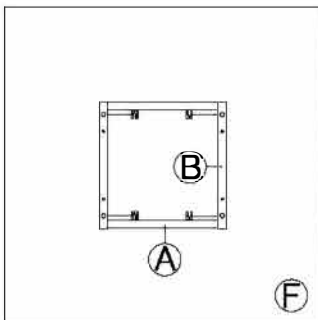

**STEP 5 :**

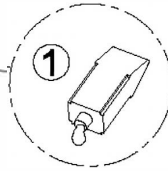
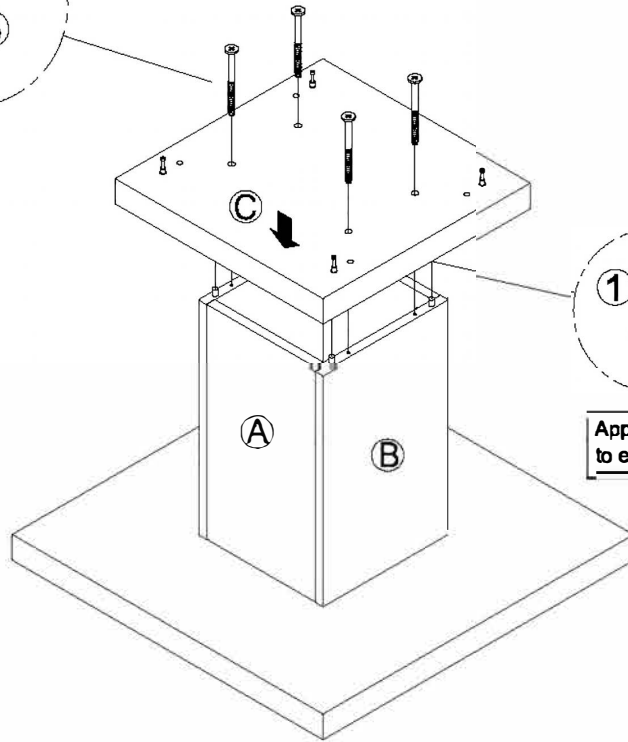
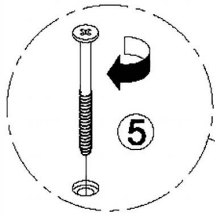
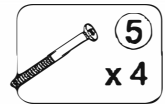

Apply glue on all wooden dowels to ensure integrity of the structure.

**STEP 6 :**

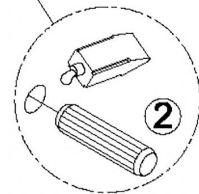
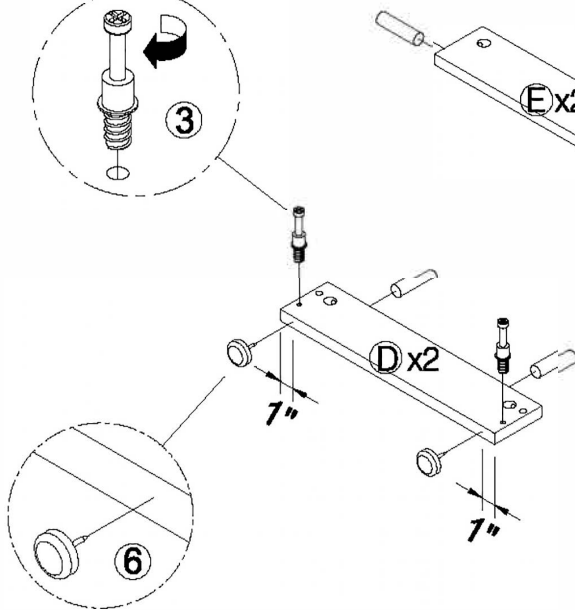
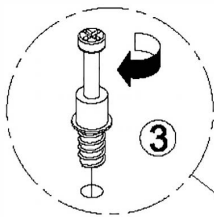
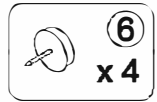
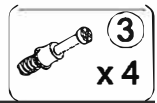
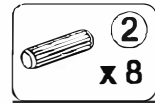

Apply glue on all wooden dowels to ensure integrity of the structure.

**STEP 7 :**

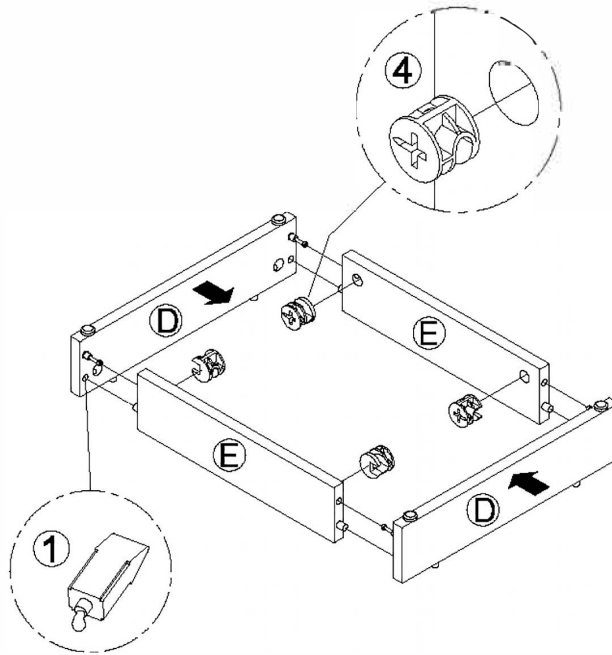

Apply glue on all wooden dowels to ensure integrity of the structure.

**STEP 8 :**

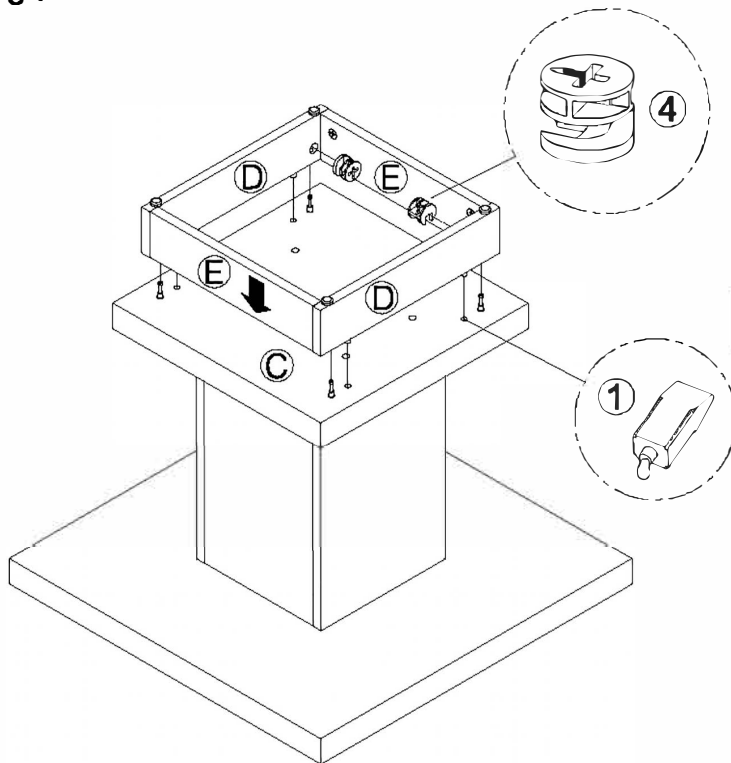
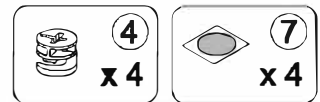

Apply glue on all wooden dowels to ensure integrity of the structure.

**FINISH**

