

# ANCONA

## Acero

### STANDARDS

- ASME A112.18.1
- CSA B125.1
- NSF 61-9
- LISTED IAPMO/cUPC

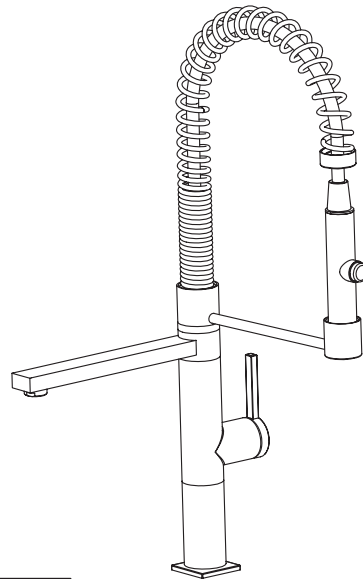

### Flow Rate Chart

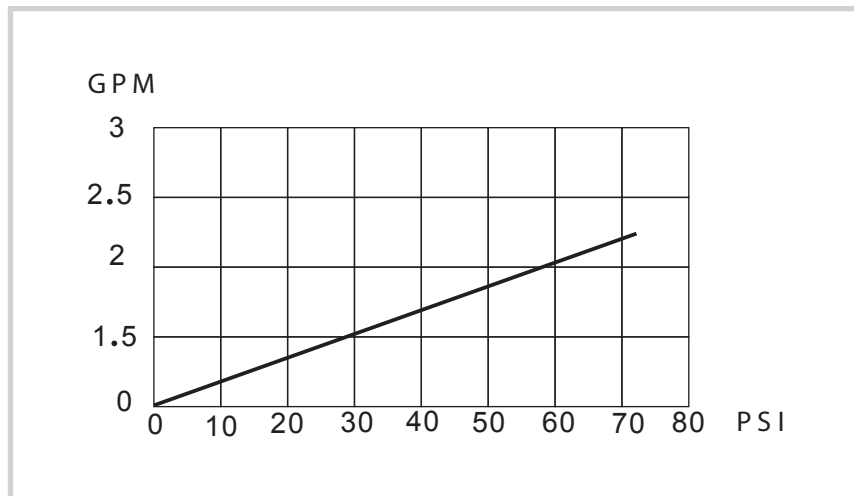

## Helpful Information

### Tools:

Gather the necessary tools as shown below to complete the installation of this faucet. Some may not be needed depending on the model of faucet you are installing. Check with your local hardware store on the requirements of your installation situation.

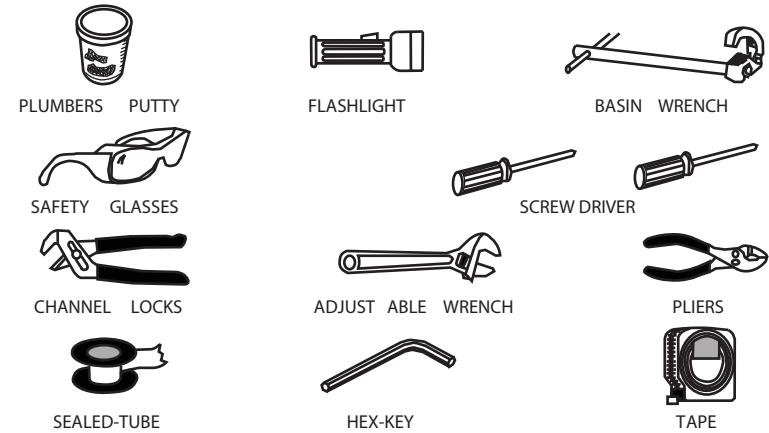

## Configuration

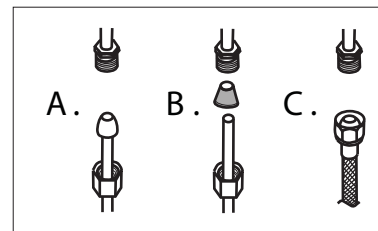

Connect to water supply lines with either:  
 (A) 3/8" O.D. copper tubing (ball nose risers with the coupling nuts or;  
 (B) 3/8" copper tubing (no ball) with supplied tube head interior connector or;  
 (C) IPS faucet connectors (1/2" )

## Important

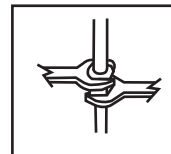

Tighten connection with two wrench to prevent damage to tube body. Be careful not to bend the stem as this will void the product warranty.

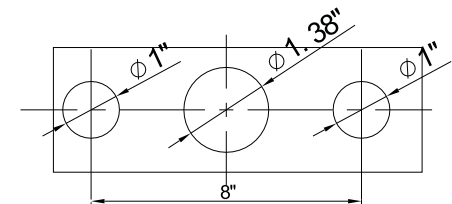

## Installation size map

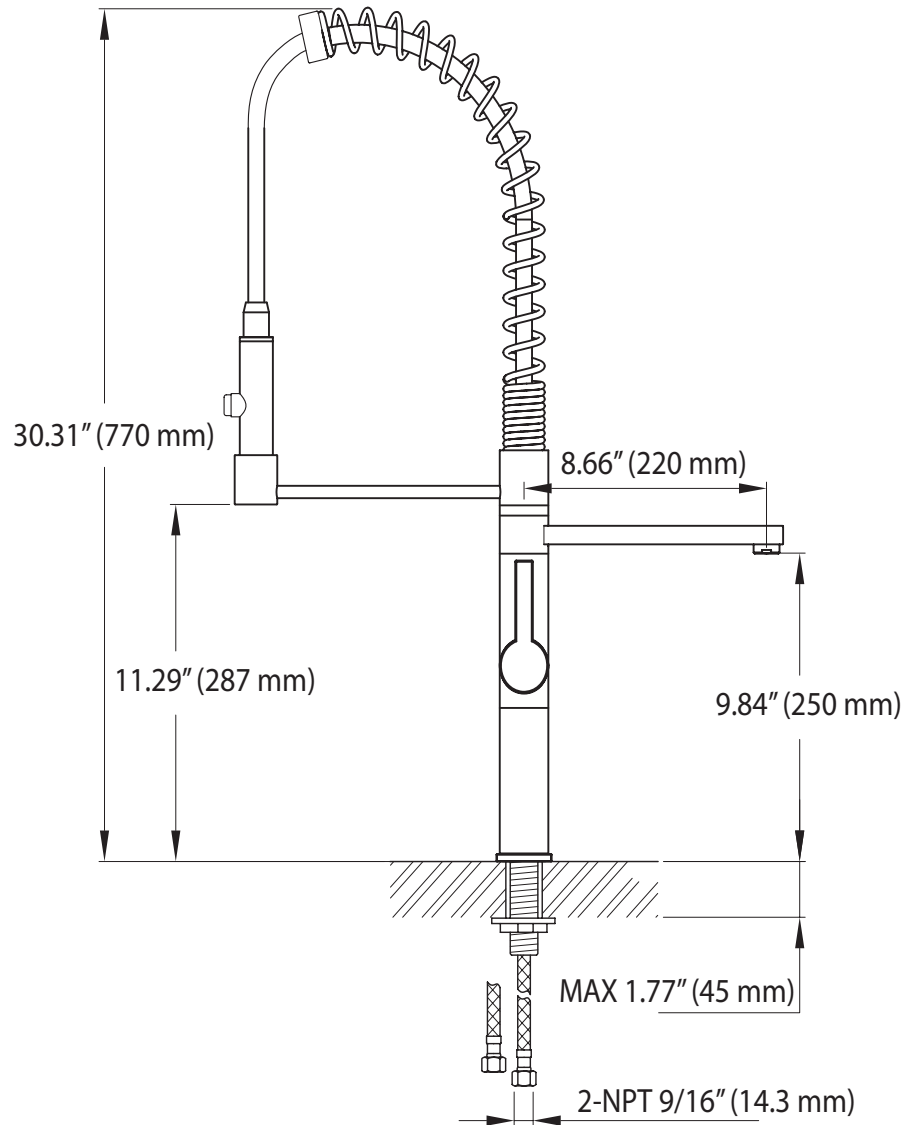

## Three Hole Installation

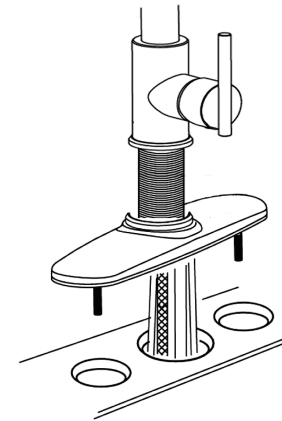

Step 1: Repeat steps 1 to 3 from Single Hole Installation.

Step 2: Insert plate before inserting faucet body into sink deck (C).

Step 3: Repeat steps 5 and 6 from Single Hole Installation.

Step 4: Secure plate (A).

Step 5: Securing all connectors (B): Ensure all connections are tightly set in place to avoid leakage.

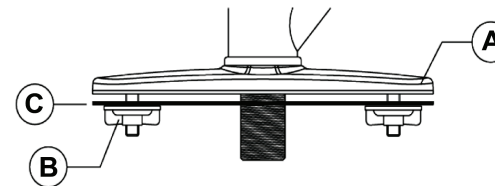

## Test Faucet Installation

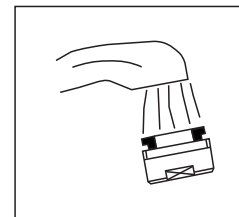

- Move handle into "OFF" position.
- Turn on water supplies. Check connections for leaks.
- Remove hand shower and let both hot and cold water run for one minute. This will help clean any debris that might otherwise clog the system. Replace hand shower.
- Operate handle up and down, in cold and hot positions, to flush water lines thoroughly.

### Maintenance:

Simply rinse the surface with clear water or mild liquid detergents (if necessary) Dry the faucet with a clean soft cotton cloth. Do not use any cleaning agents containing acids, polish abrasives, or harsh cleaners.

# Single Hole Installation

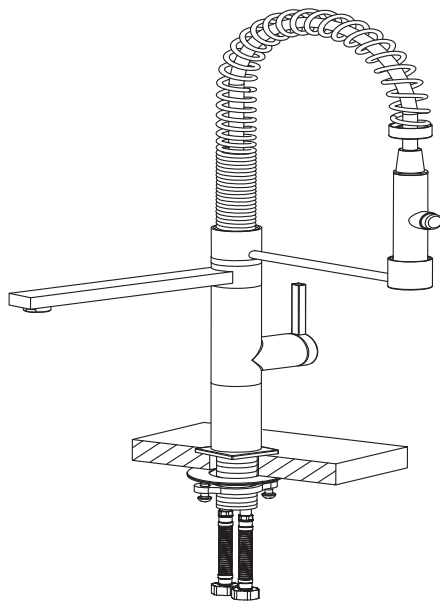
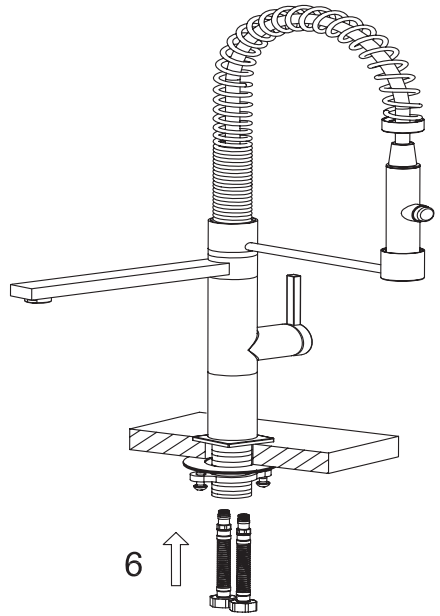
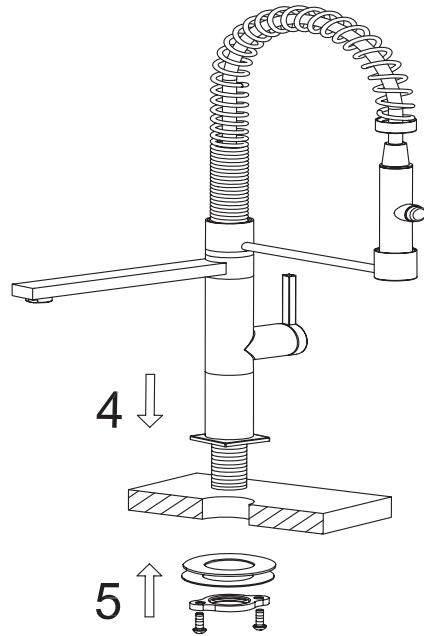
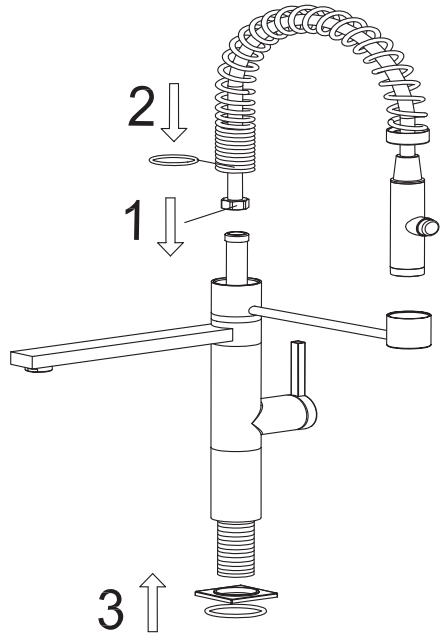

**WARNING**

Ensure hoses are tightly screwed into position as they may move during transportation and installation.



**ATTENTION**

Assurez-vous de bien serrer les embouts de chaque Tuyau car ils peuvent se dévisser lors du transport – bien valider après l'installation aussi

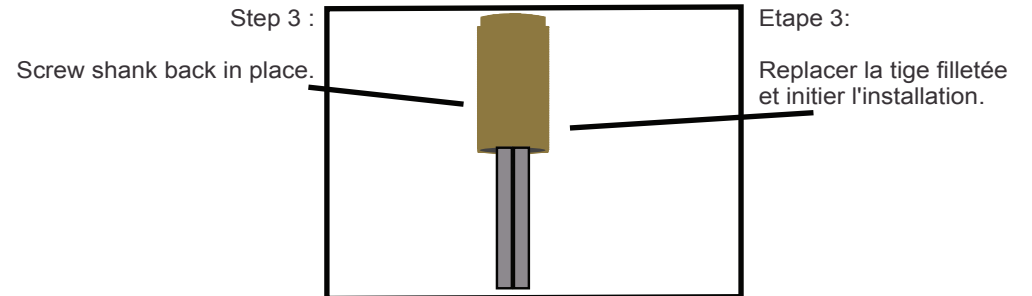
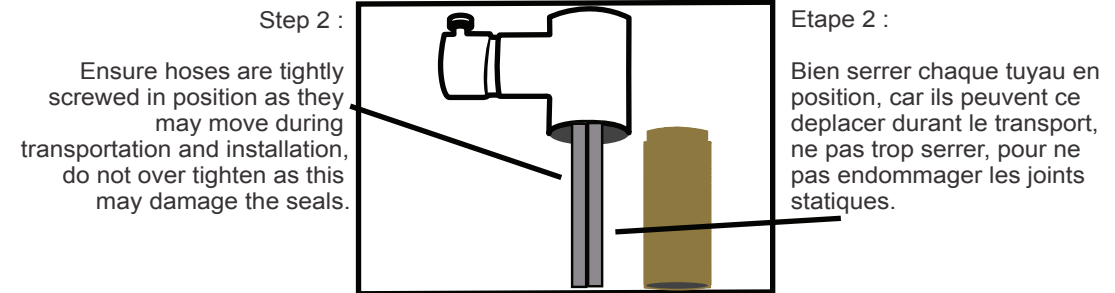
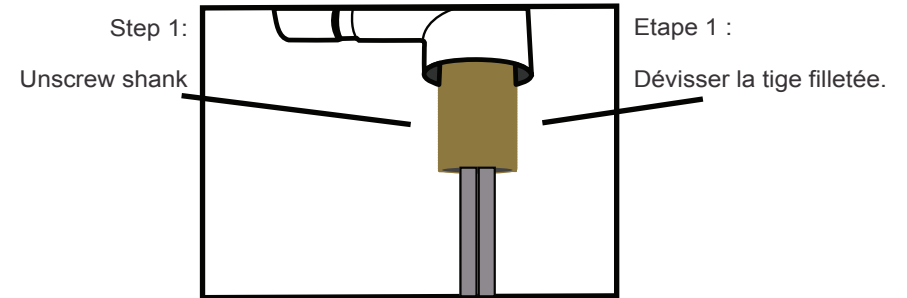

# ANCONA

## Acero

### NORMES

- ASME A112.18.1
- CSA B125.1
- NSF 61-9
- LISTED IAPMO/cUPC

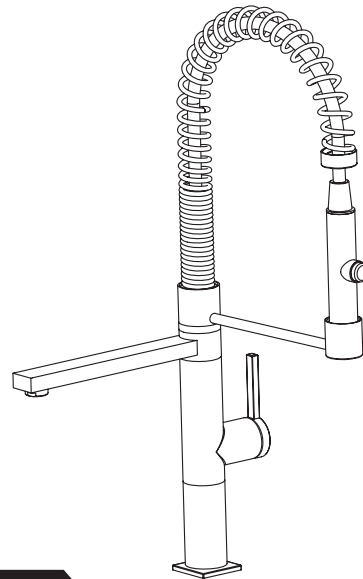

### Diagramme de débit

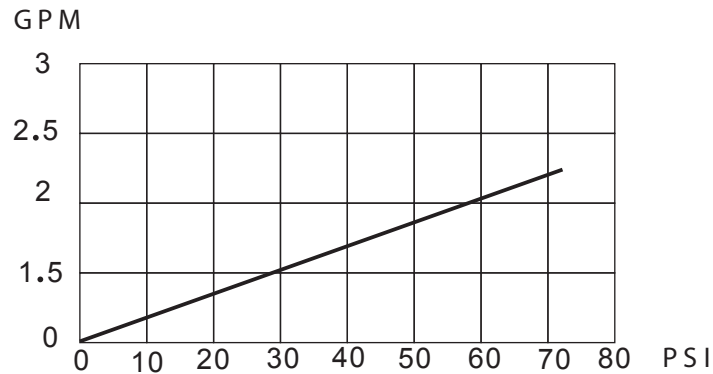

2014-09-16 MAAN4105-01

### Information utile

#### Outils:

Réunissez les outils nécessaires comme montrés ci-dessous, pour compléter l'installation de ce robinet. Certains peuvent ne pas être requis, selon le modèle du robinet que vous installez. Vérifiez avec votre quincaillerie locale sur les exigences de votre situation d'installation.



### Configuration

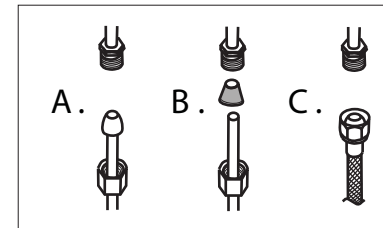

Connectez à une ligne d'alimentation en eau avec soit :

- (A) 3/8" O.D. tuyau de cuivre (clapet-bille à tube plongeur avec les écrous d'accouplement ou ;
- (B) 3/8" tubes plongeurs (sans clapet-bille) avec connecteur de tube de tête intérieur ;
- (C) Connecteurs de robinet IPS (1/2").

### Important

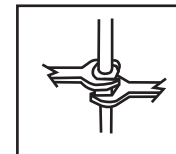

Serrez la connexion avec deux clés anglaises pour empêcher des dommages au corps du tuyau. Faites attention de ne pas plier la tige, puisque ceci annulera la garantie du produit.

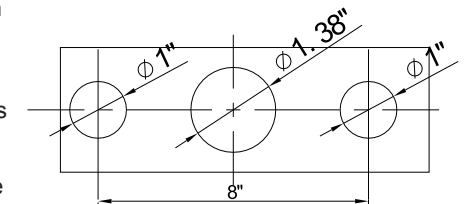

## Carte de dimension d'installation

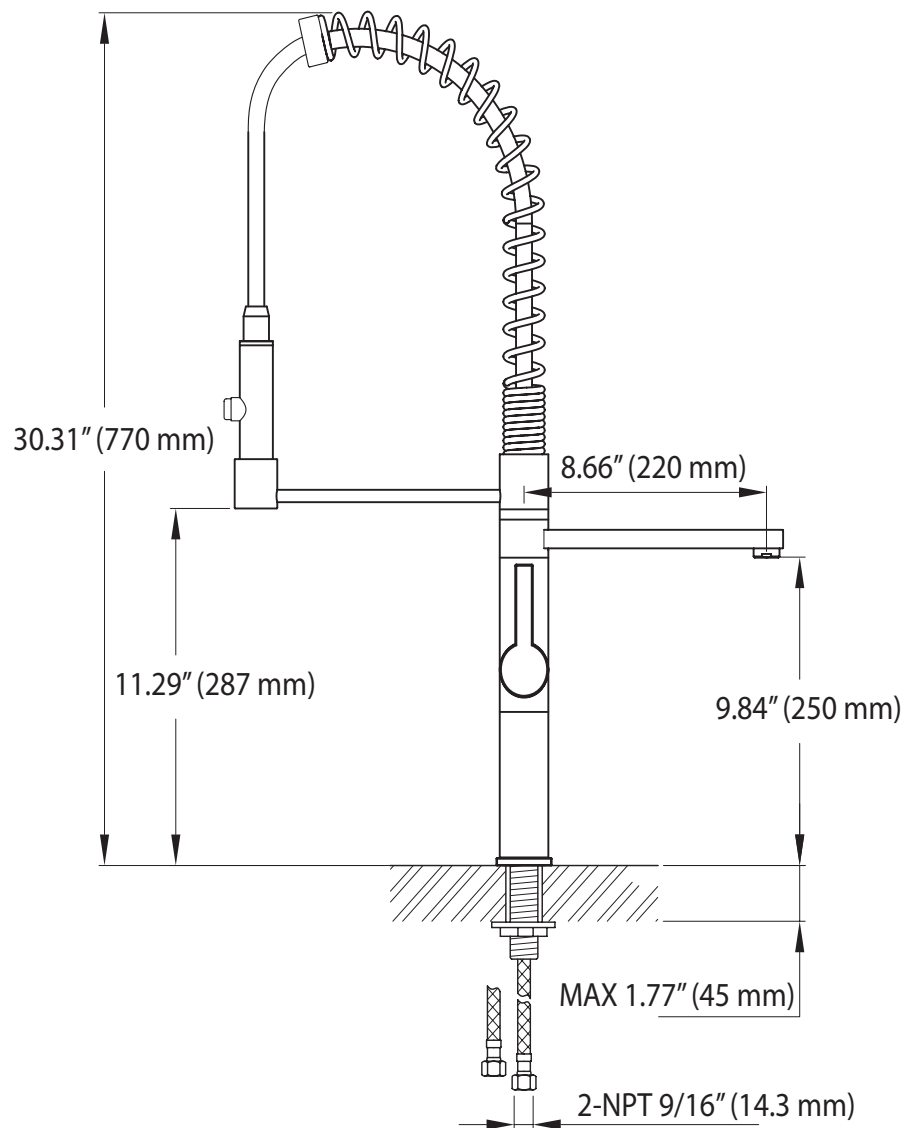

## Installation à trois orifices

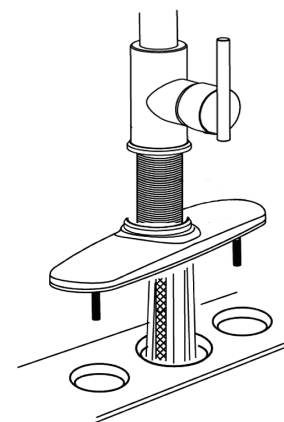

Étape 1: Répétez les étapes 1 à 3 de l'Installation à un orifice.

Étape 2: Insérez la plaque avant d'insérer le robinet dans le comptoir (C).

Étape 3: Répétez les étapes 5 et 6 de l'Installation à un orifice.

Étape 4: Serrez bien en place la plaque (A).

Étape 5: Validez tous les raccords (B) afin d'assurer qu'il n'y a pas de fuites d'eau.

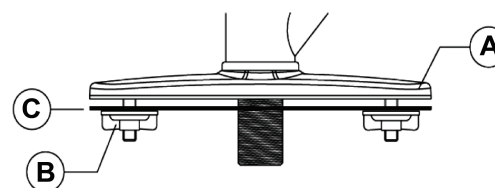

## Testez l'installation du robinet

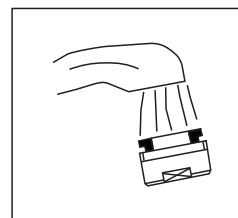

- Déplacez la poignée vers le bas à la position "OFF".
- Fermez l'alimentation d'eau. Vérifiez les connexions pour des fuites.
- Retirez la manette à jet et laissez l'eau froide et chaude couler pour une minute. Ceci aidera à nettoyer tout débris qui pourrait autrement bloquer le système. Remplacez la manette à jet.
- Opérez la poignée vers le haut et le bas, avec les positions d'eau froide et chaude, pour vider les lignes d'eau à fond.

## Entretien:

Rincez simplement la surface avec de l'eau claire ou du savon liquide doux (si nécessaire). Essayez le robinet avec un linge de coton doux propre. N'utilisez pas d'agent nettoyant contenant de l'acide, des abrasifs ou des nettoyeurs puissants.

# Installation à un orifice

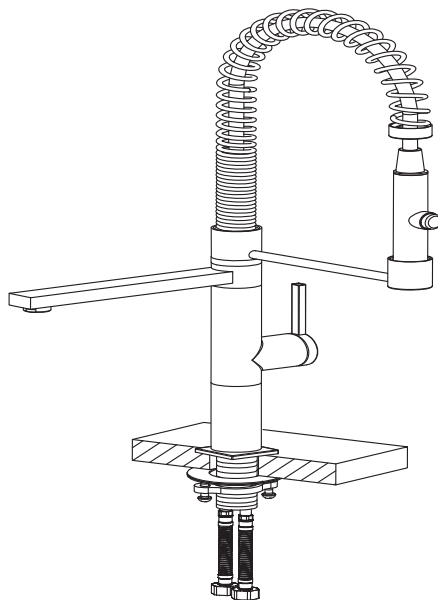
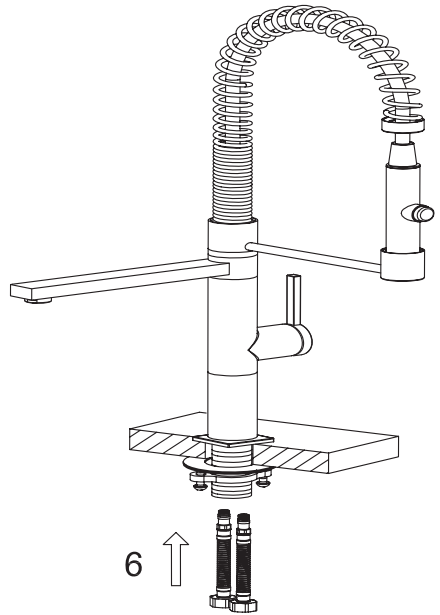
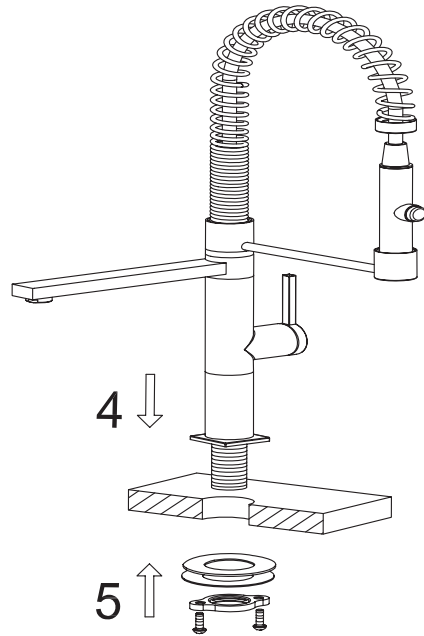
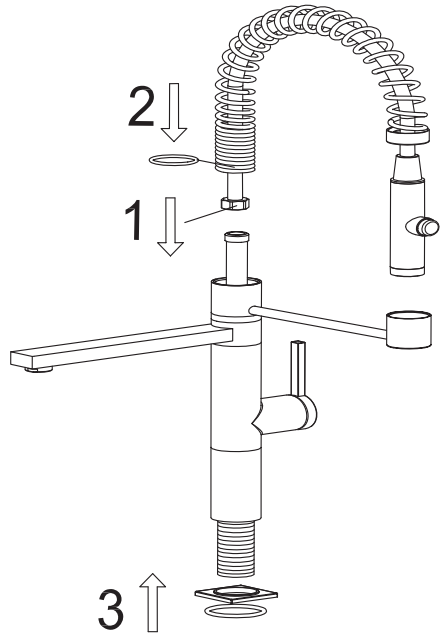

**WARNING**

Ensure hoses are tightly screwed into position as they may move during transportation and installation.



**ATTENTION**

Assurez-vous de bien serrer les embouts de chaque Tuyau car ils peuvent se dévisser lors du transport – bien valider après l'installation aussi

