

# Assembly Instructions

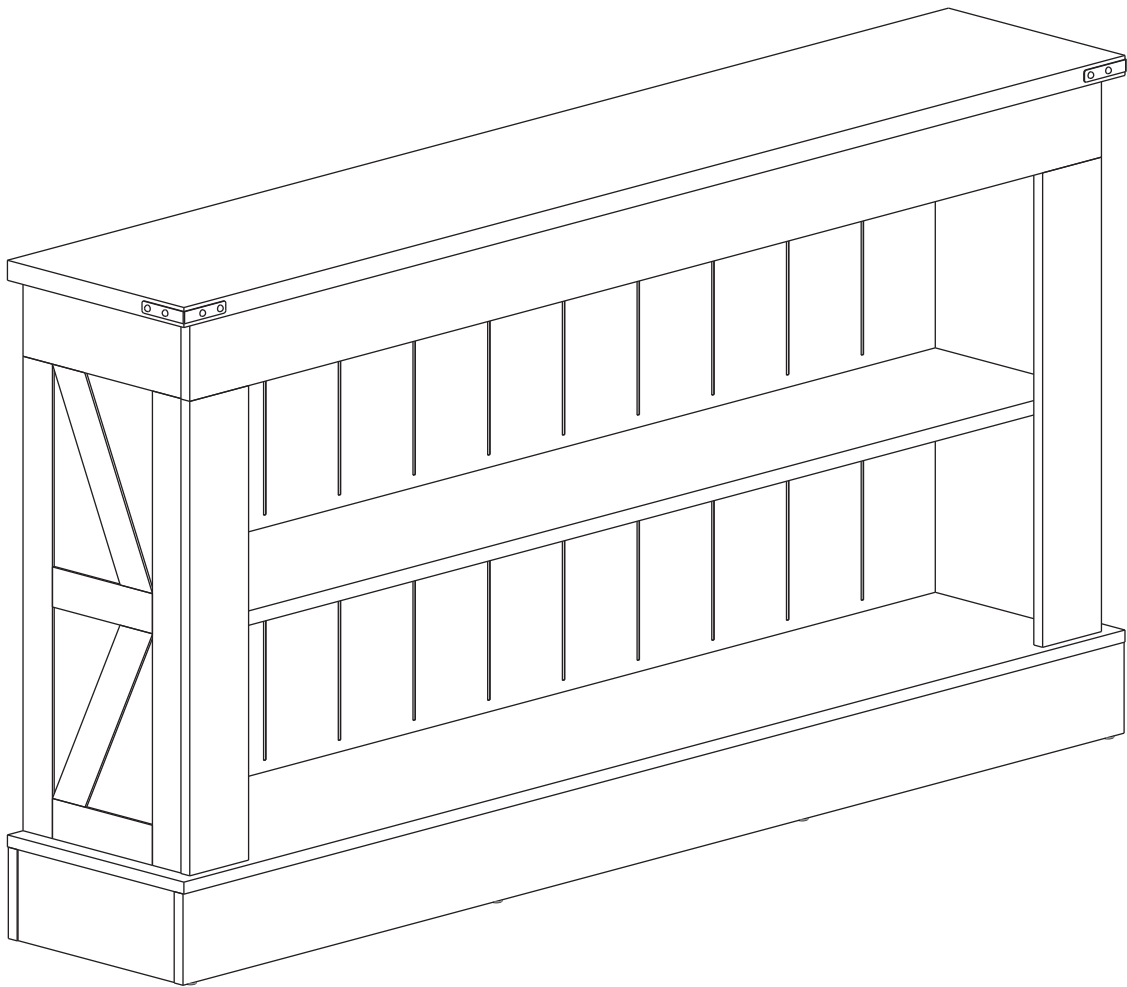

# Contact Us

## We're here to help you.

Your satisfaction is our top priority. If you encounter any issues with this product, such as missing or damaged parts, we're here to help. Please retain the original packaging and take photos of the packaging and the product, then contact us as soon as possible.

### **Warm Tips**

1. Carefully read these instructions and keep them for future reference.
2. Check the parts list and confirm everything's there before starting assembly.
3. When assembling, put all parts on a soft, smooth surface like a carpet to avoid scratches.
4. Don't fully tighten screws until all parts are confirmed in place to avoid misalignment.

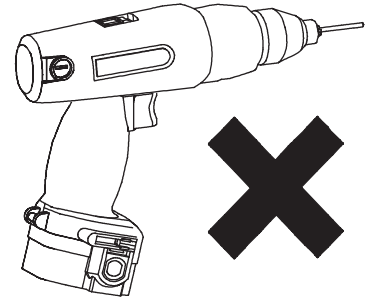
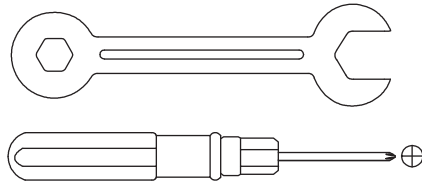
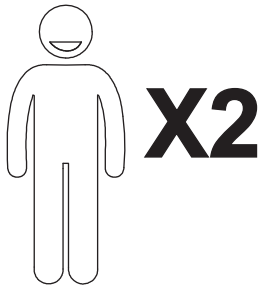

We recommend using hand tools for assembly.

If an electric screwdriver is used, reduce power and torque to avoid damage to the product.

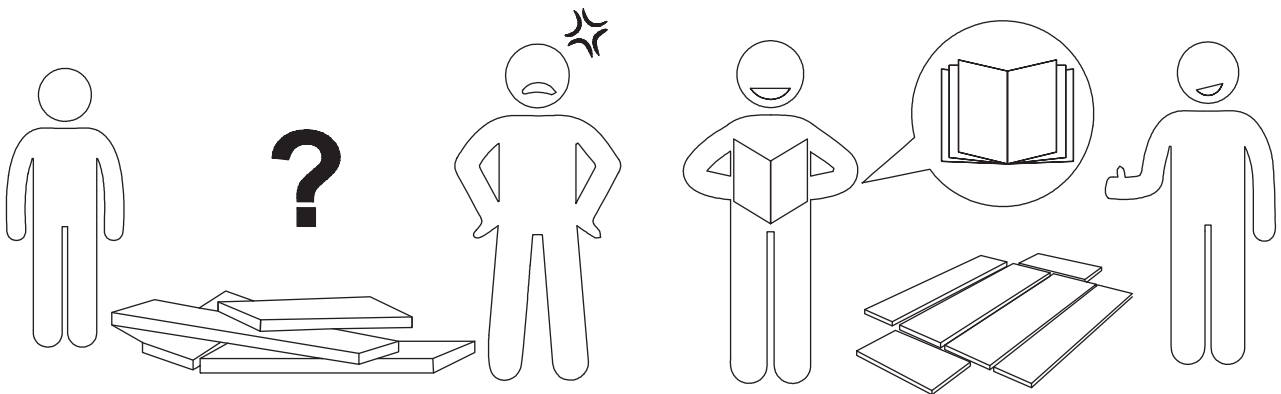

## Install tip-over restraint provided

Use of tip-over restraints may only reduce but not eliminate, the risk of tip-over

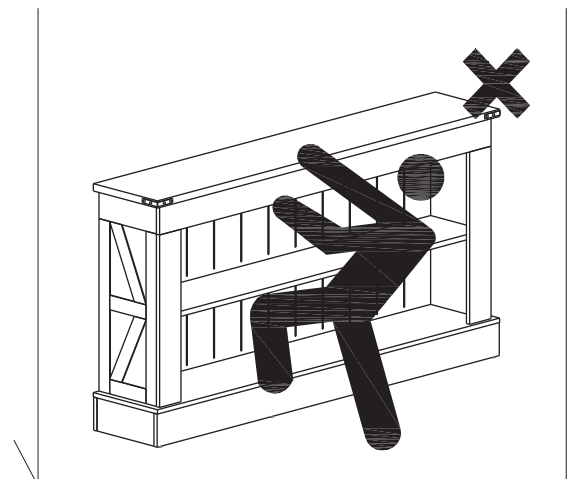
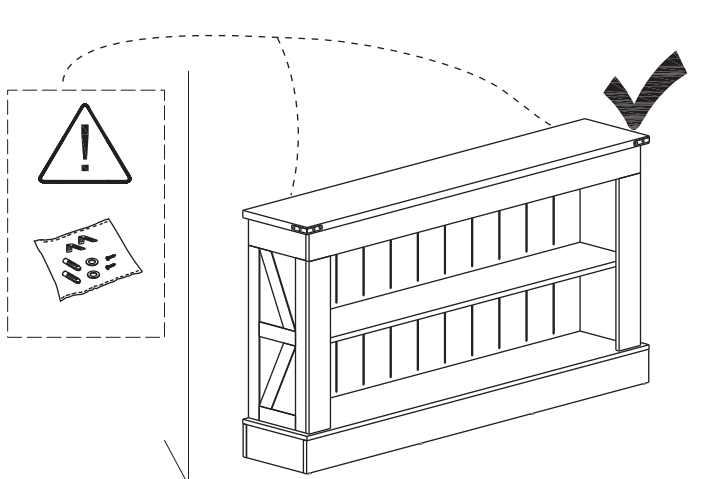

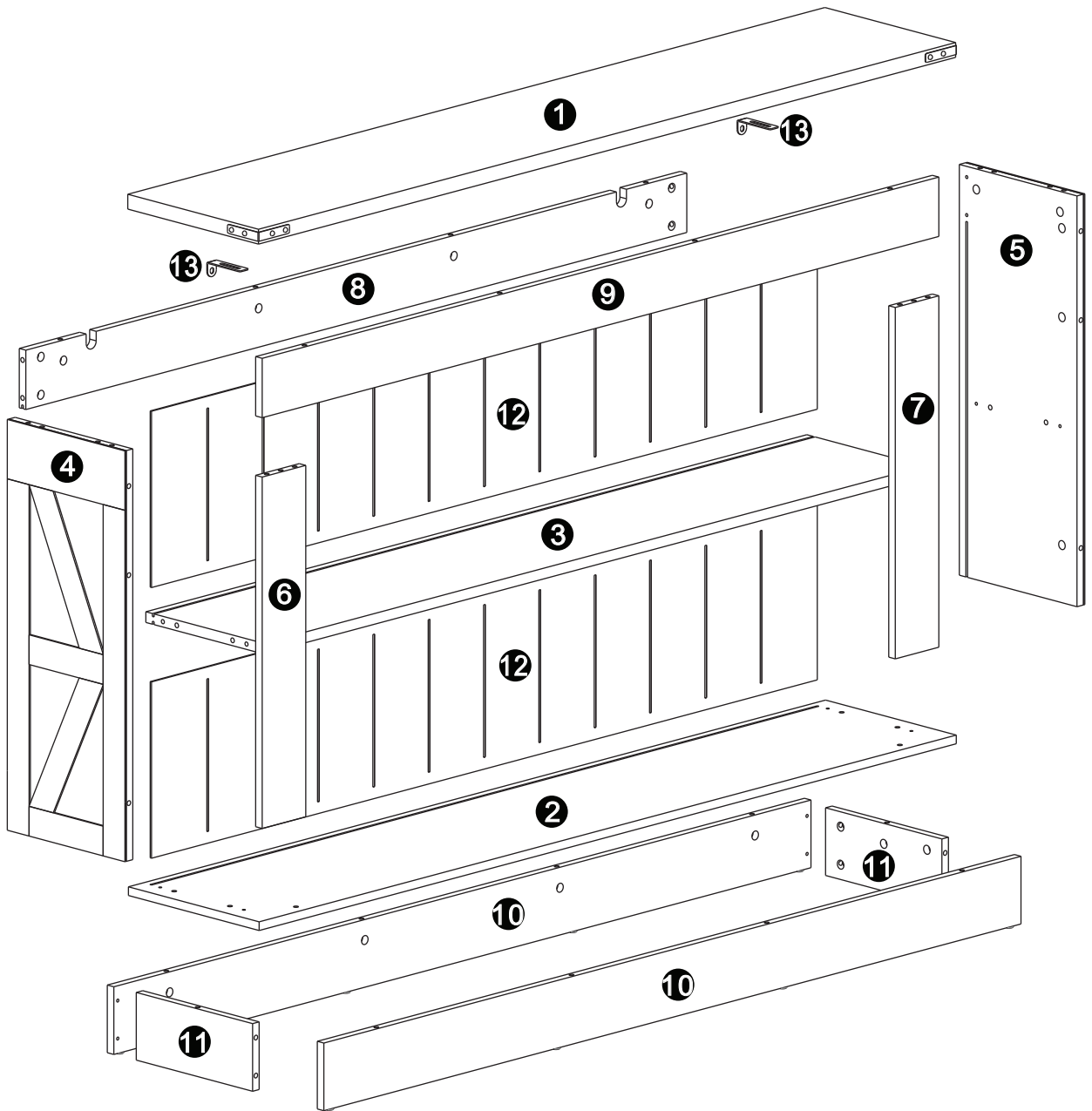







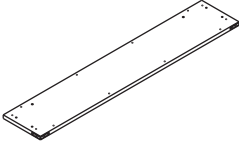
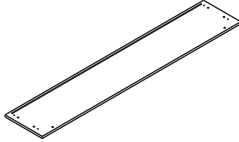

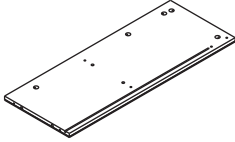
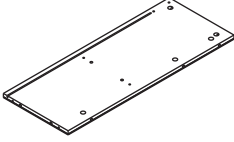
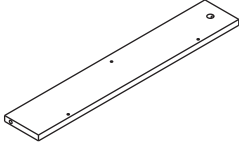
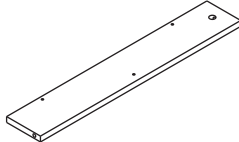
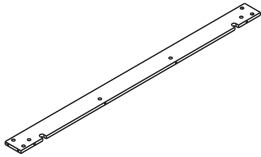
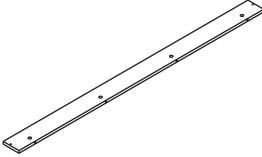
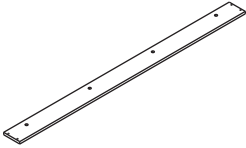
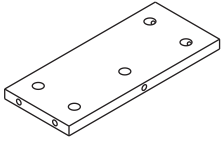
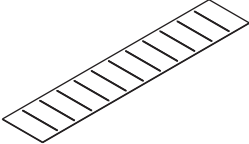
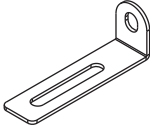
**⚠ Caution**





Make sure all parts are included. Most board parts are labeled or stamped on the raw edge. Contact us for a free replacement if you encounter any damaged or missing parts.

# Parts List

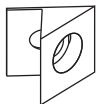
<b>1</b>  1 pc	<b>2</b>  1 pc	<b>3</b>  1 pc	<b>4</b>  1 pc	<b>5</b>  1 pc
<b>6</b>  1 pc	<b>7</b>  1 pc	<b>8</b>  1 pc	<b>9</b>  1 pc	<b>10</b>  2 pcs
<b>11</b>  2 pcs	<b>12</b>  2 pcs	<b>13</b>  2 pcs		

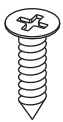
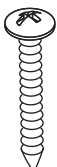
## Hardware List

A	B	C	D	E	F
					
M6x12mm	5x38mm	Ø8x30mm	M6x44.5mm	Ø15mm	
2 pcs	4 pcs	18 pcs	48 pcs	48 pcs	16 pcs

G	H	I	J	K	L
					
3.5x14mm	4X24.5mm	Ø16XØ6.2MM		Ø21mm	
16 pcs	2 pcs	2 pcs	2 pcs	4 pcs	1 pc

# Installation of Cams and Pins

Read each step carefully before starting. Each step of instruction should be performed in the correct order. If these steps are not followed in sequence, assembly difficulties may occur.

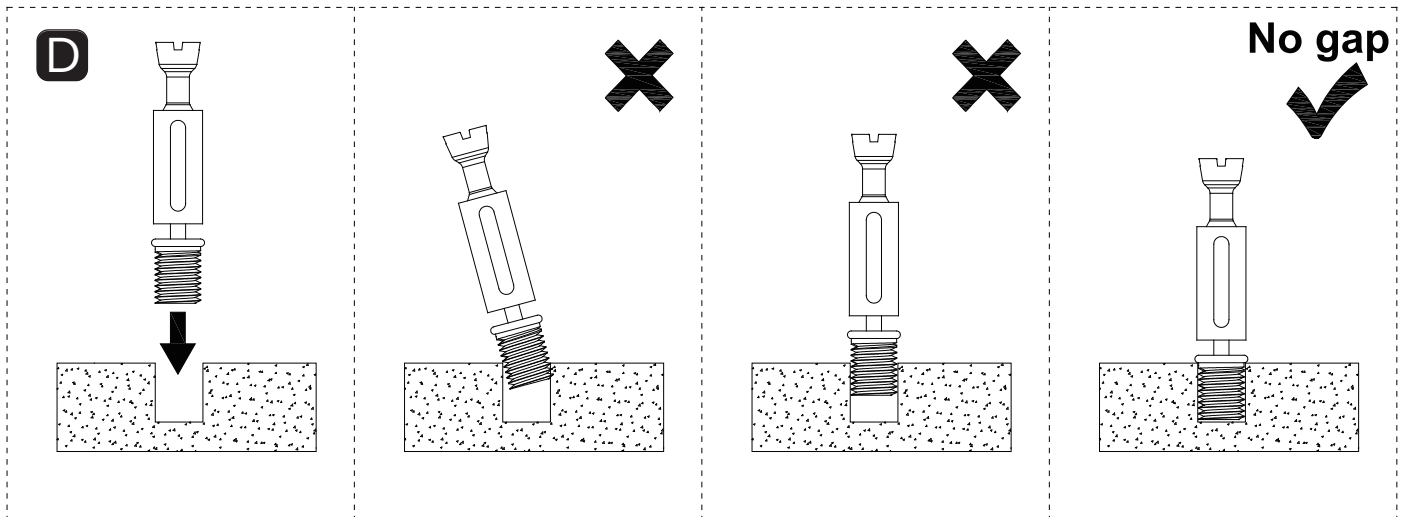
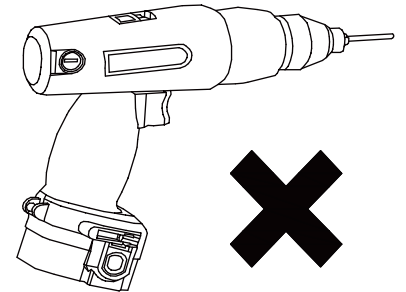

Screw the pin into the hole. Set the cams correctly by aligning the head of the cams with the lock pins. Lock the cam by turning the cam head with a screwdriver until it is tightened. Please do not use an electric screwdriver to assemble the unit.

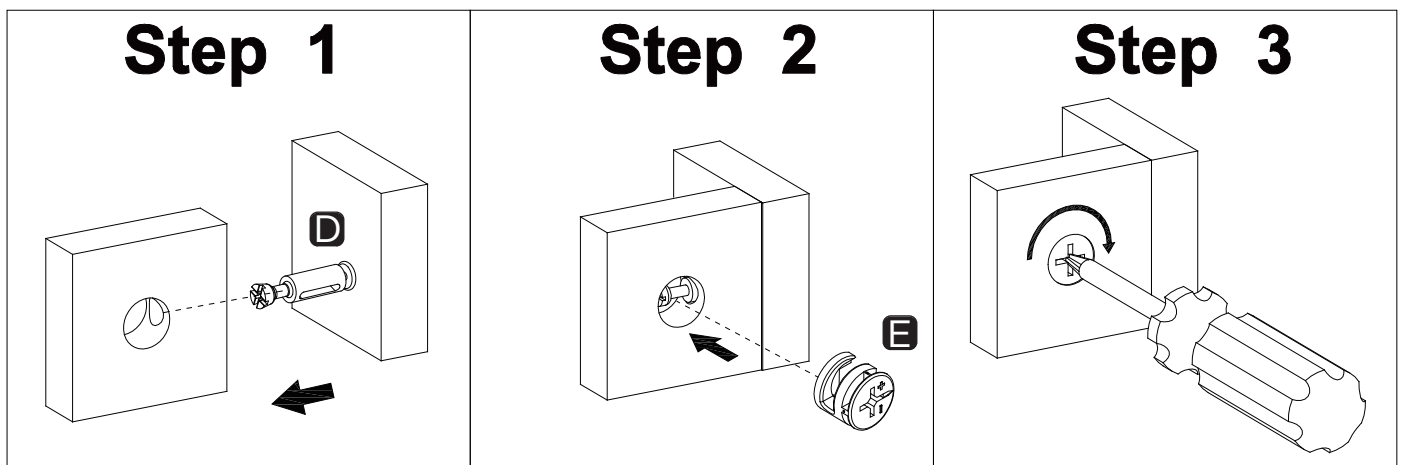

1

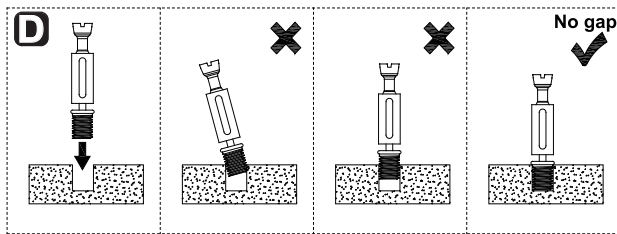

D

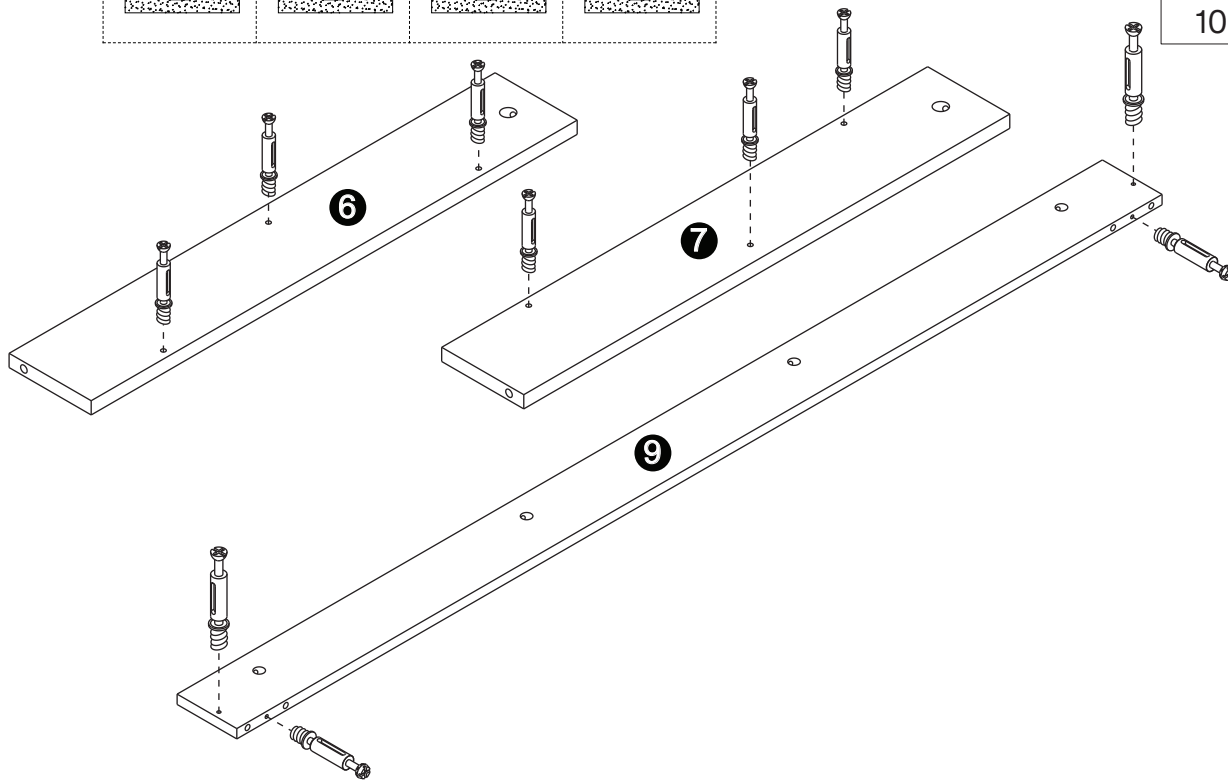
M6×44.5mm
10 pcs



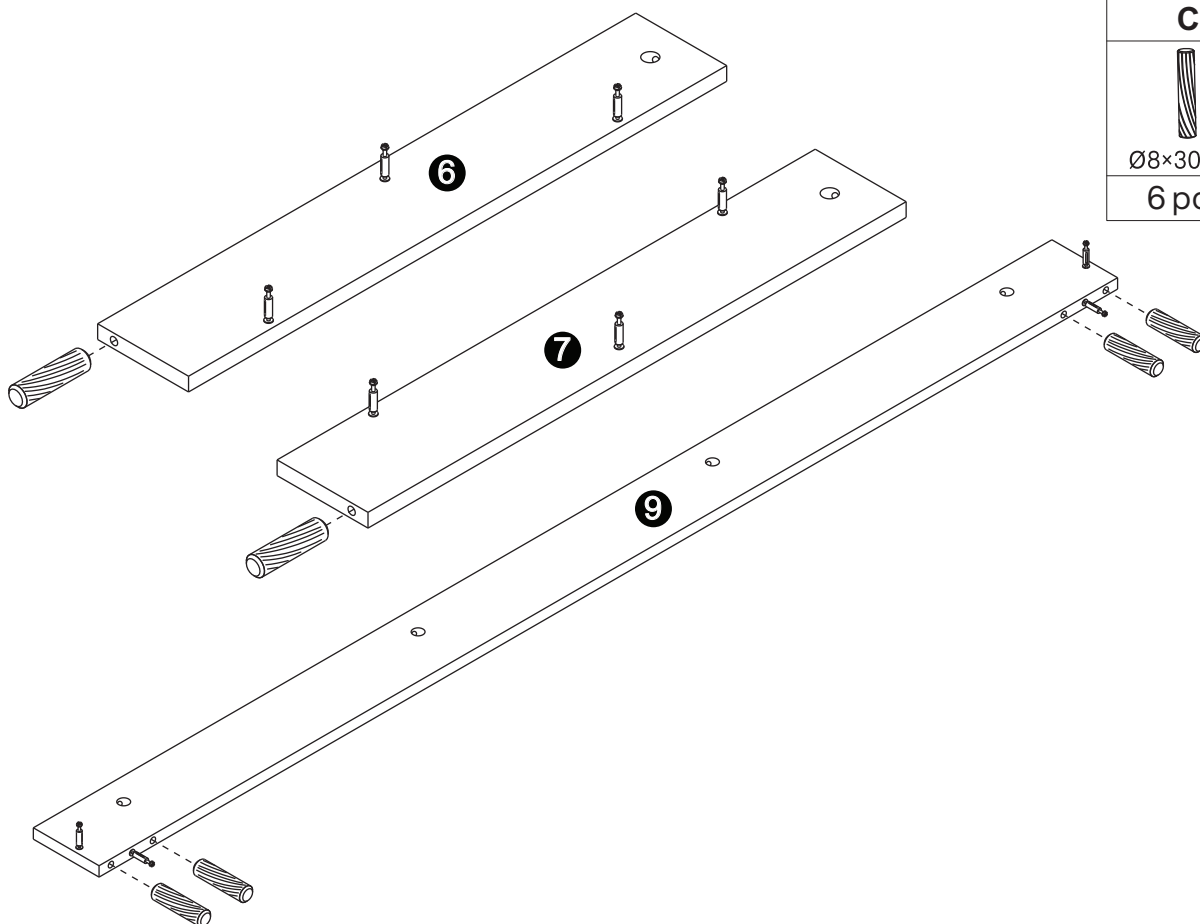

2

C

Ø8×30mm
6 pcs

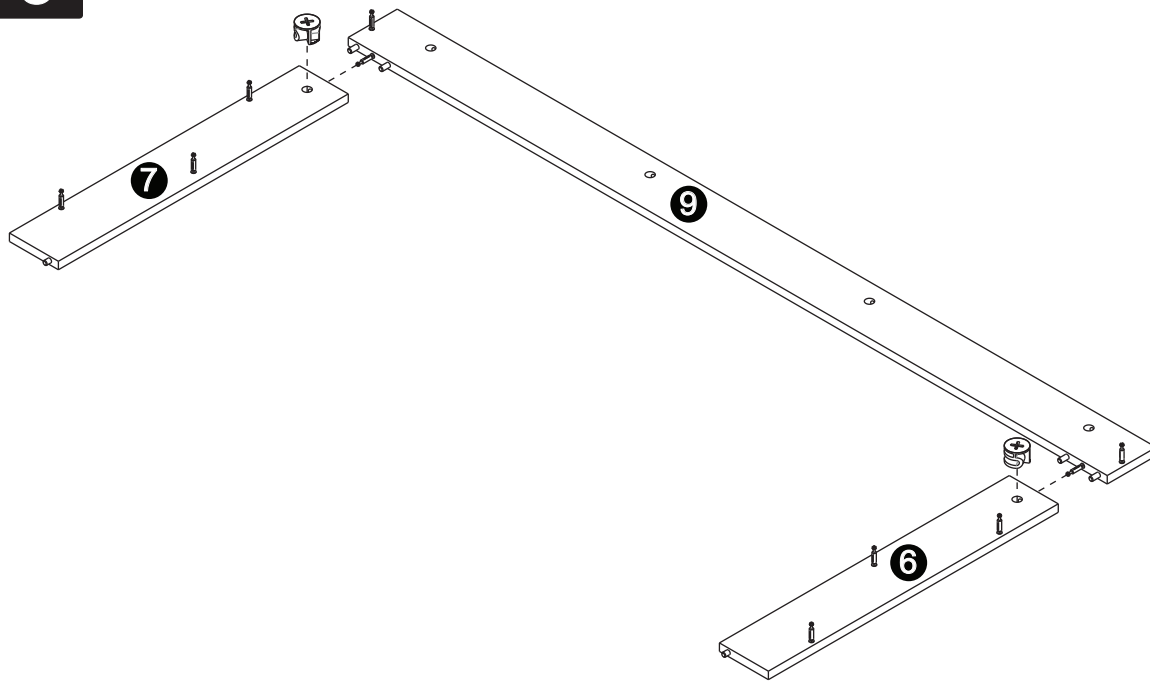

3

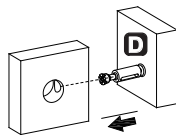
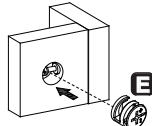
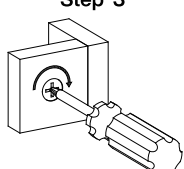

<b>E</b>

Ø15mm
2 pcs

<b>Step 1</b>

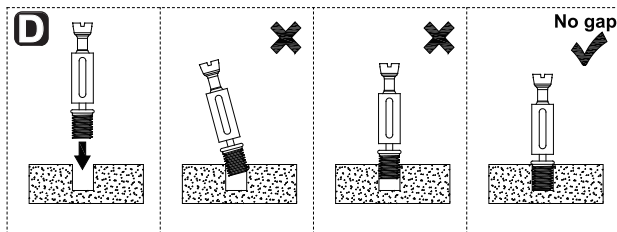
<b>Step 2</b>

<b>Step 3</b>

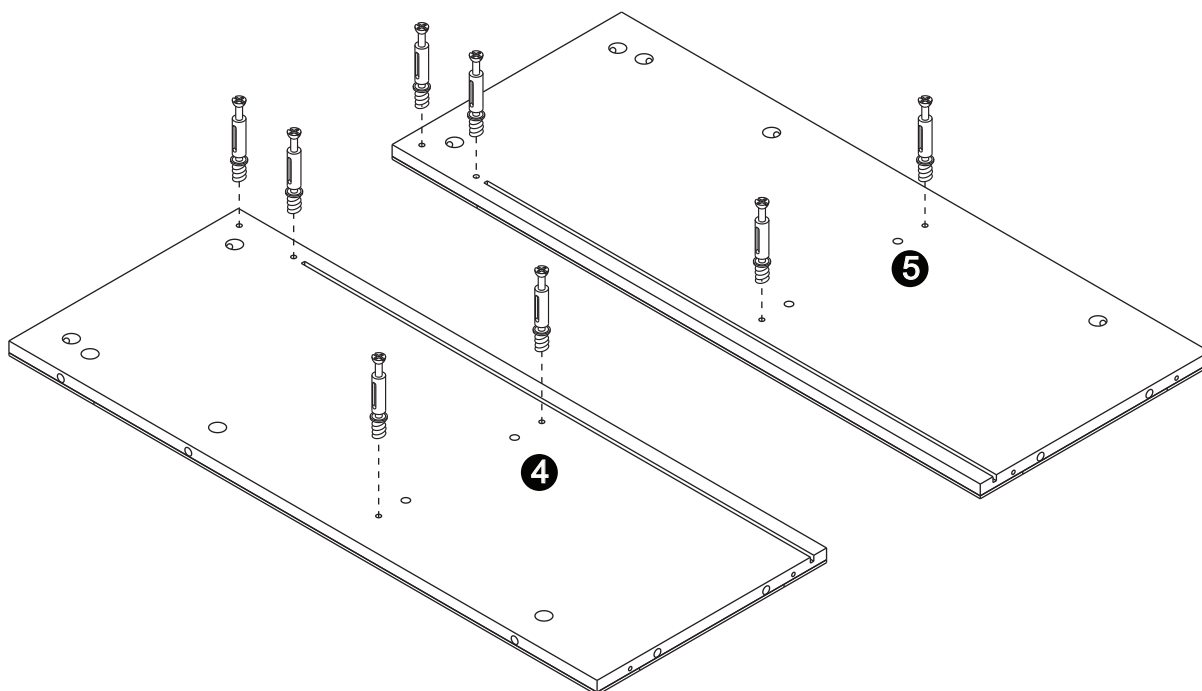

4



<b>D</b>

M6×44.5mm
8 pcs

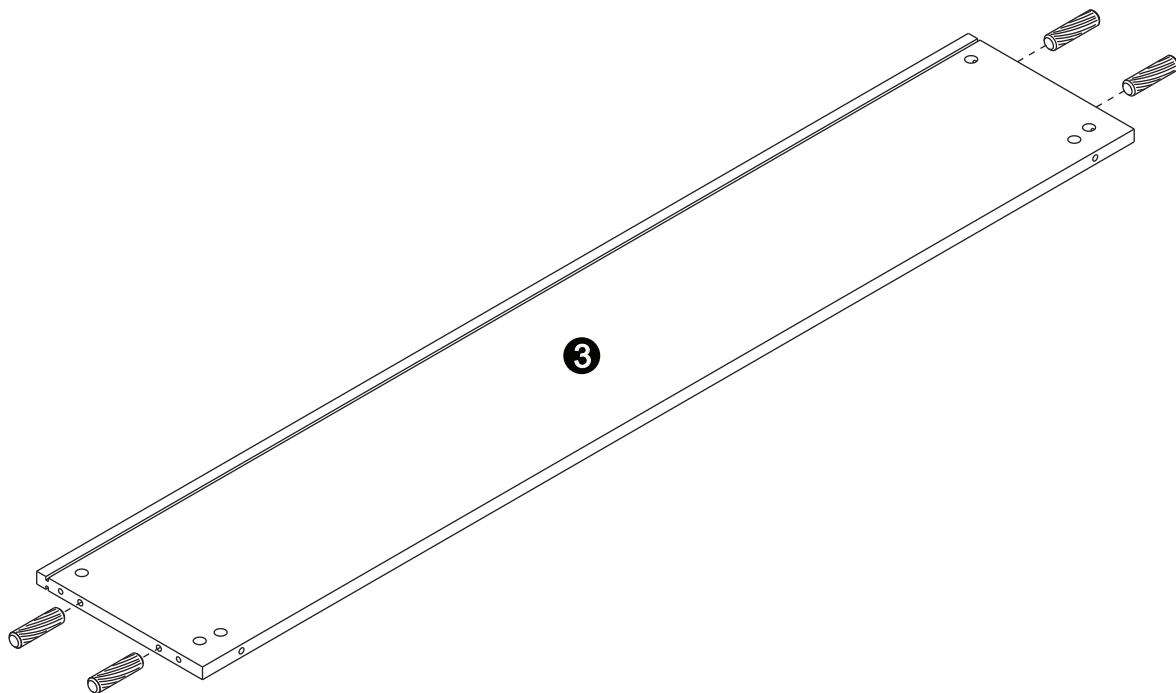

5

<b>C</b>

Ø8×30mm
4 pcs

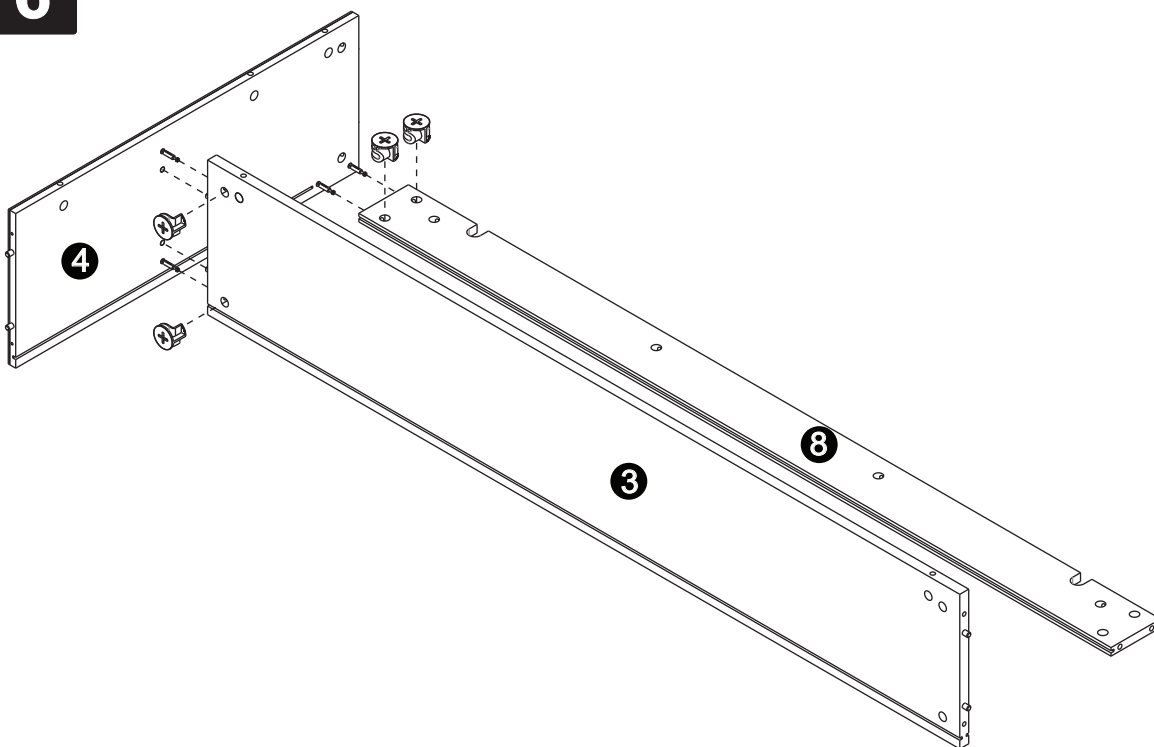

6

<b>E</b>

Ø15mm
4 pcs

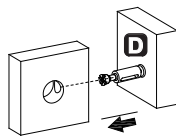

**Step 1**

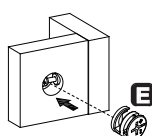

**Step 2**



**Step 3**

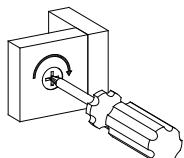

7

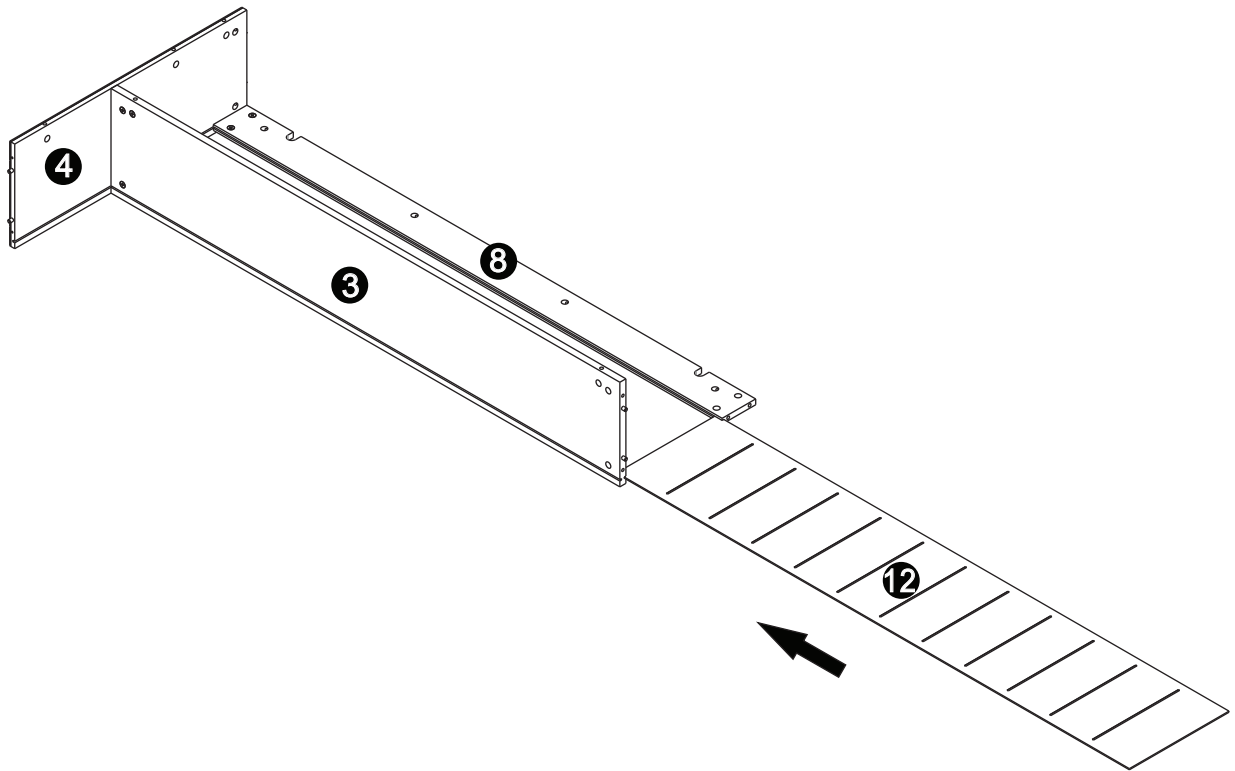

8

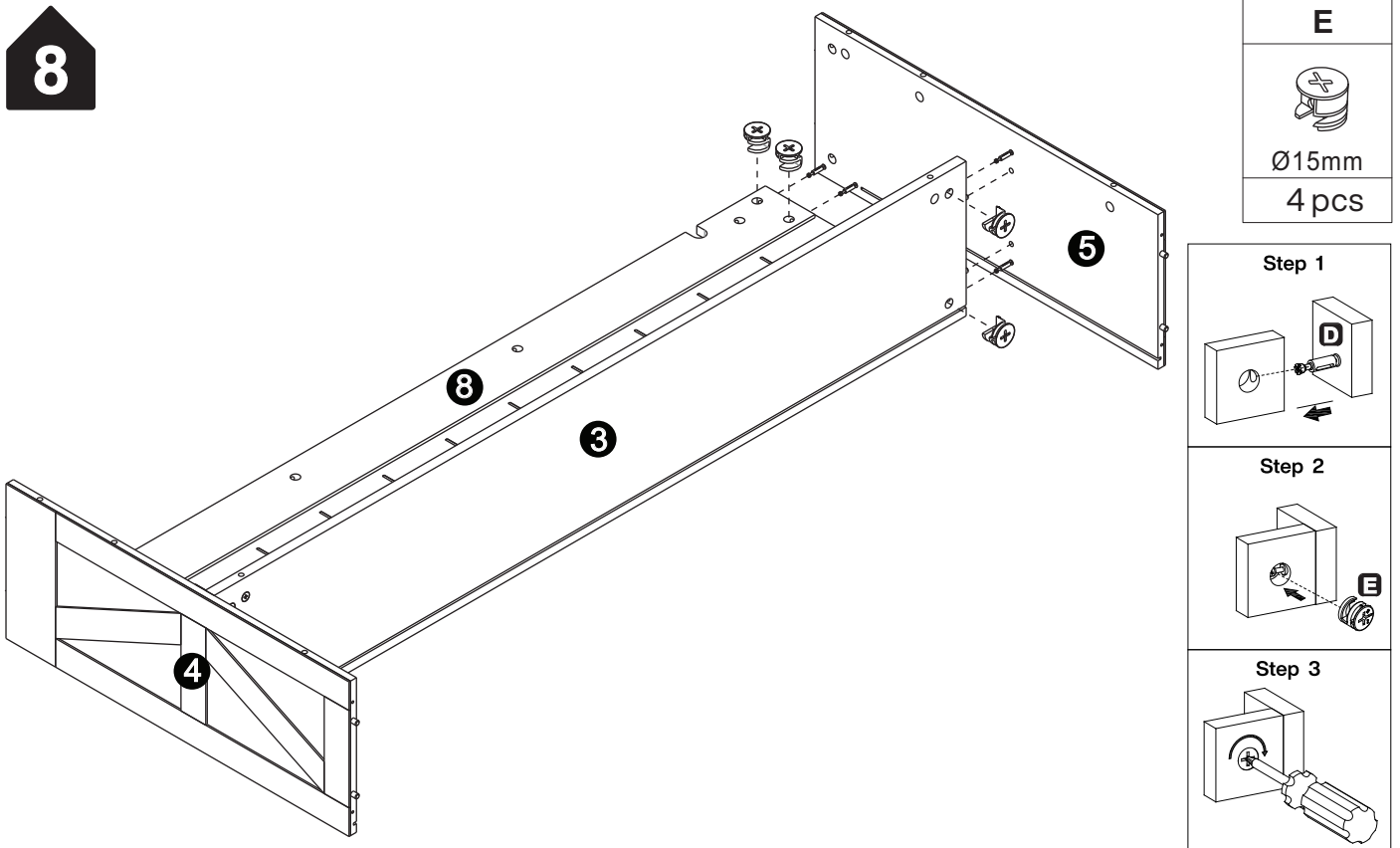

9

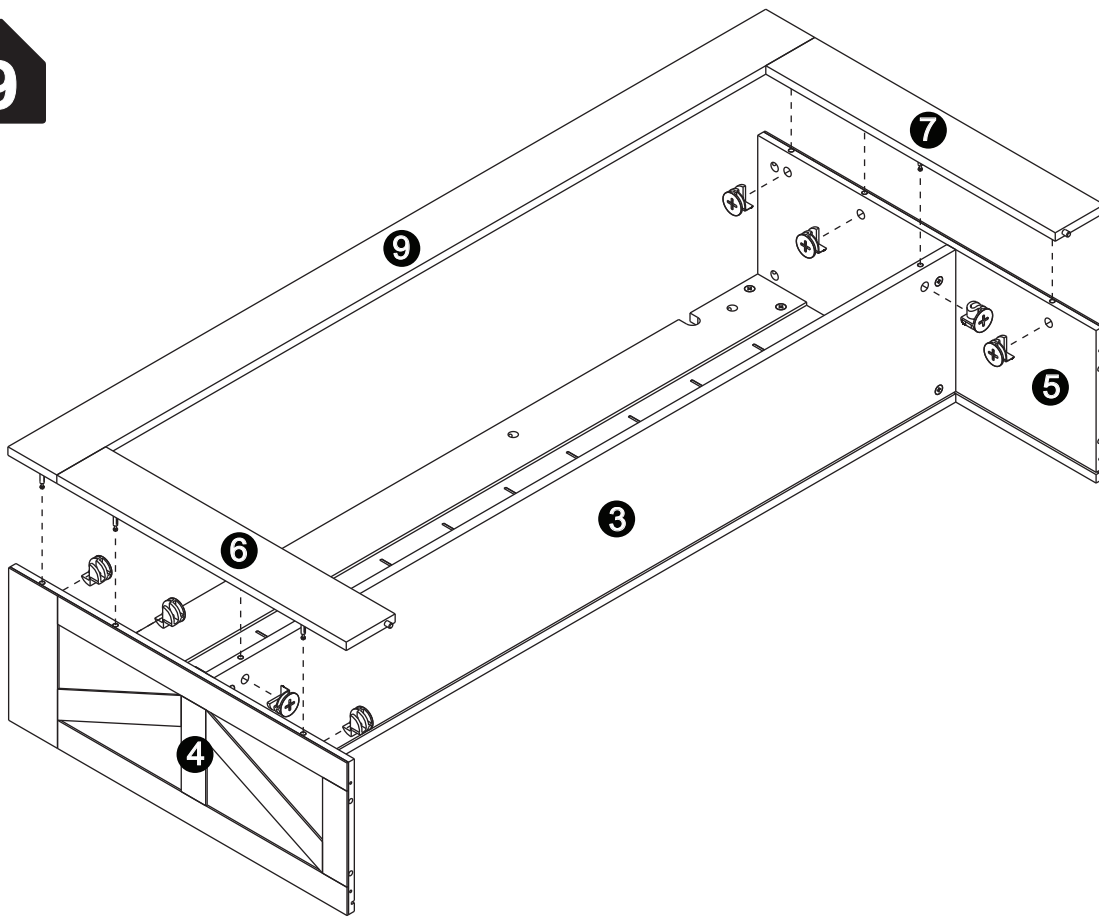

**E**



Ø15mm  
8 pcs

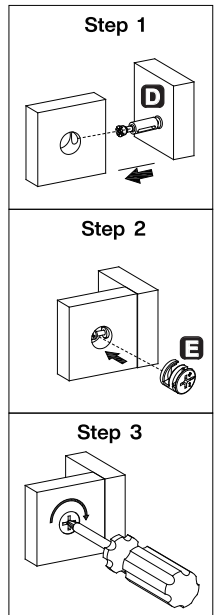

10

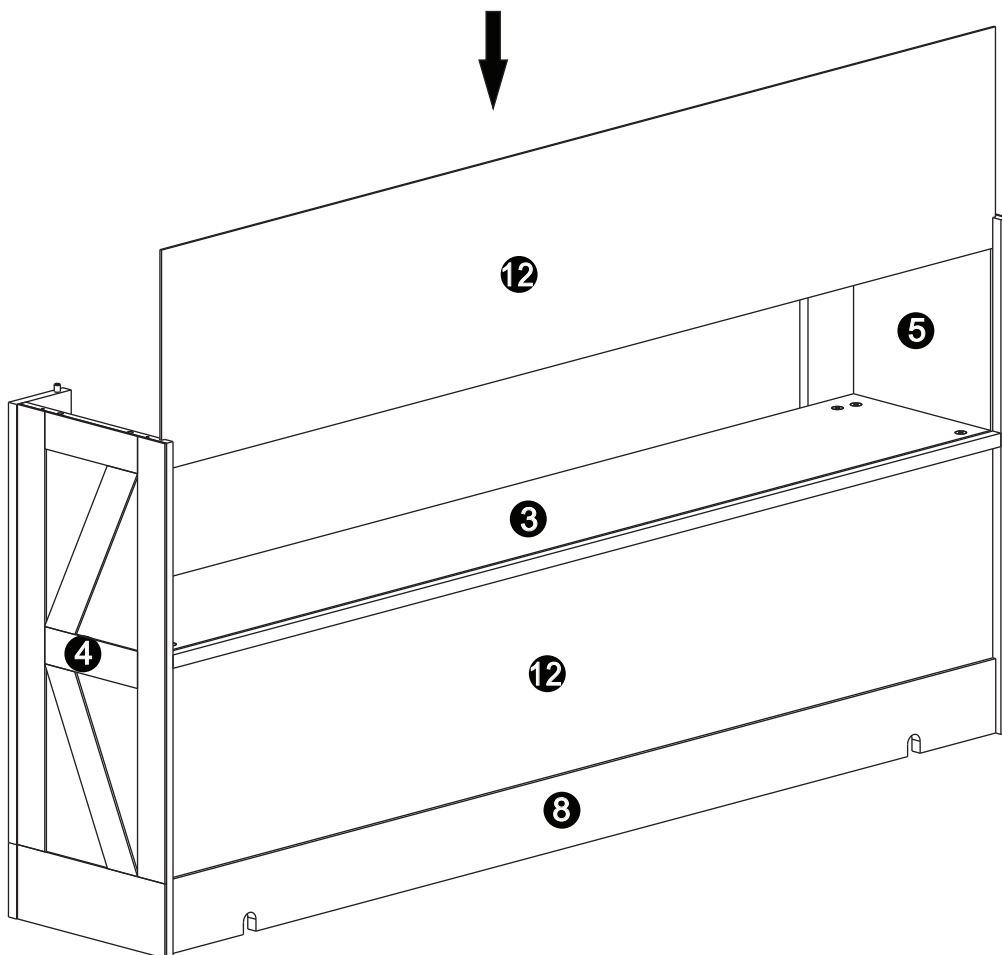

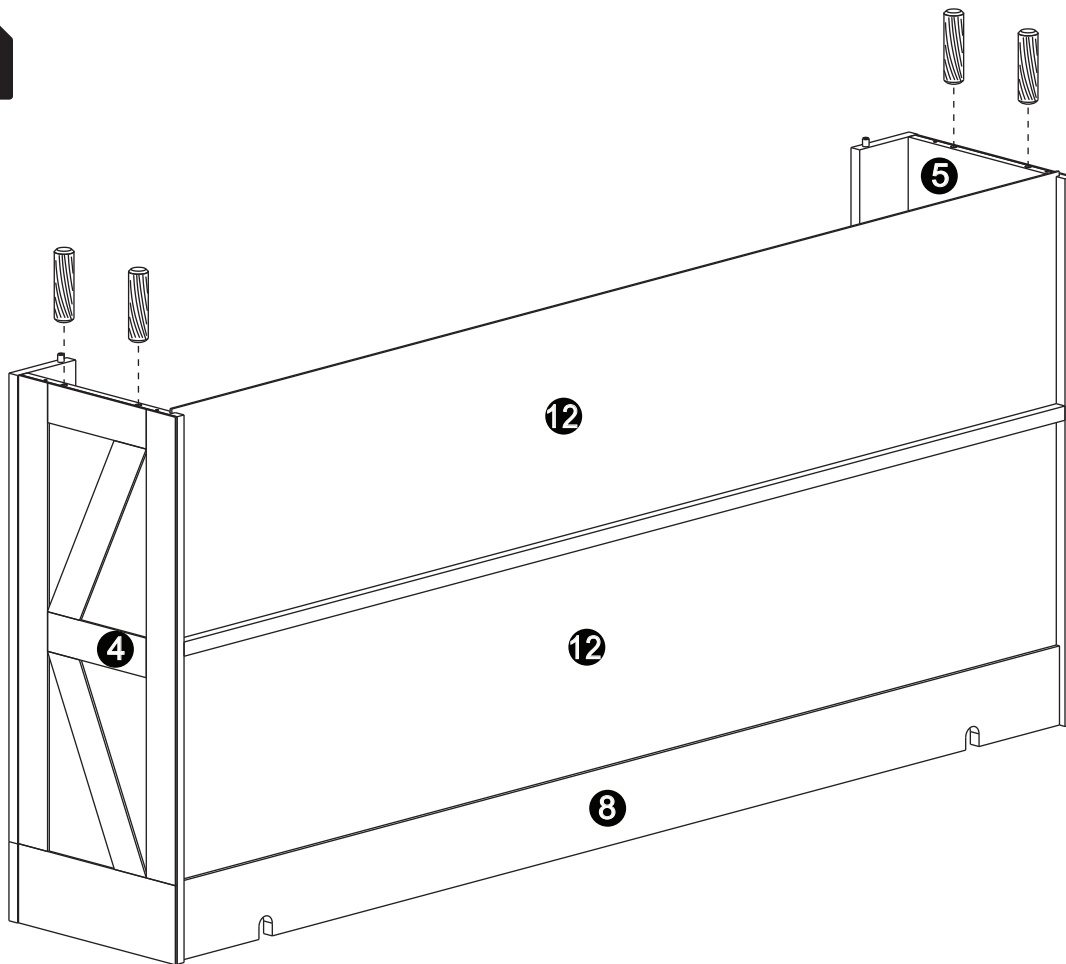

11

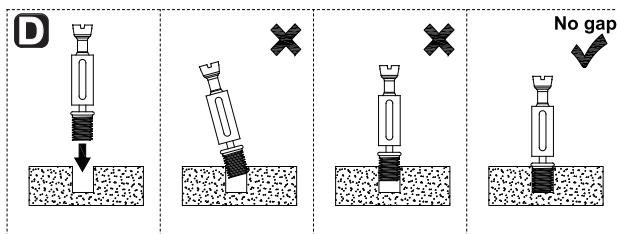

<b>C</b>

Ø8×30mm
4 pcs

12

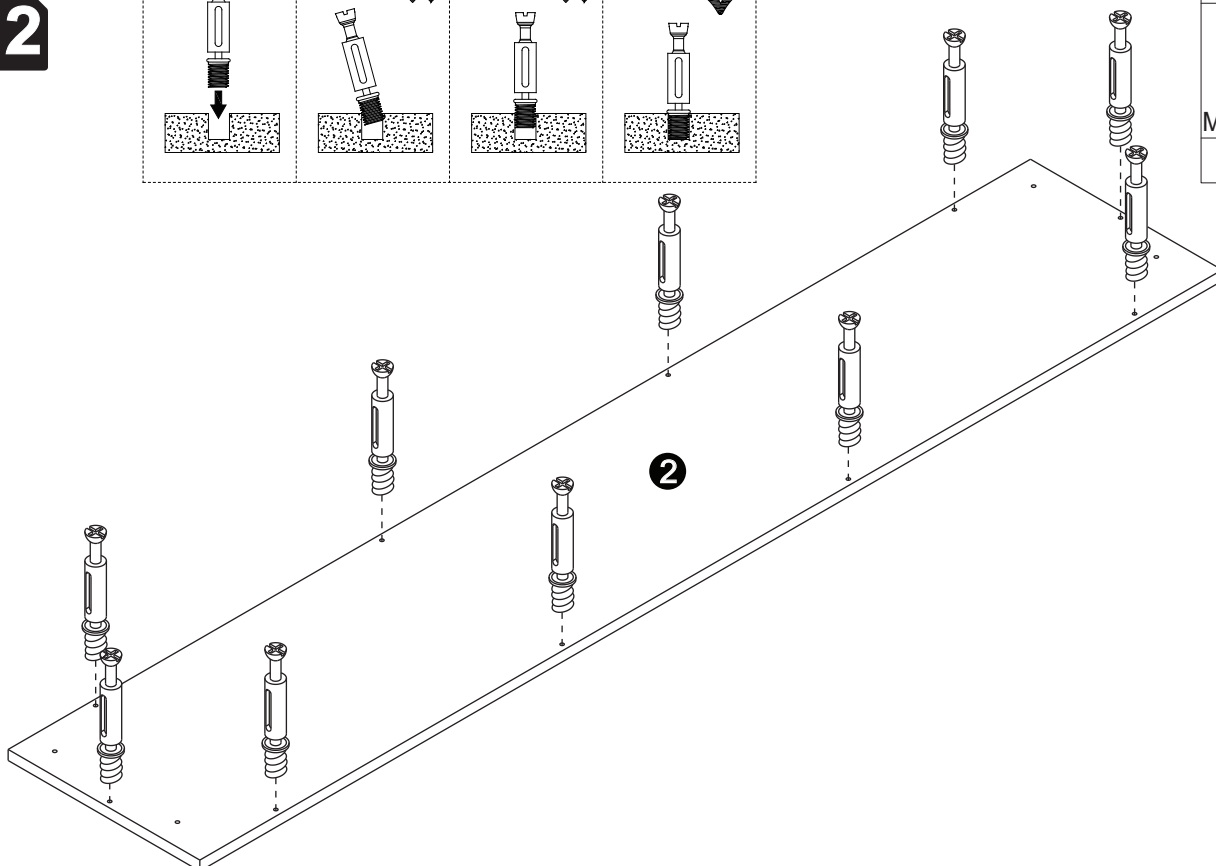

<b>D</b>

M6×44.5mm
10 pcs



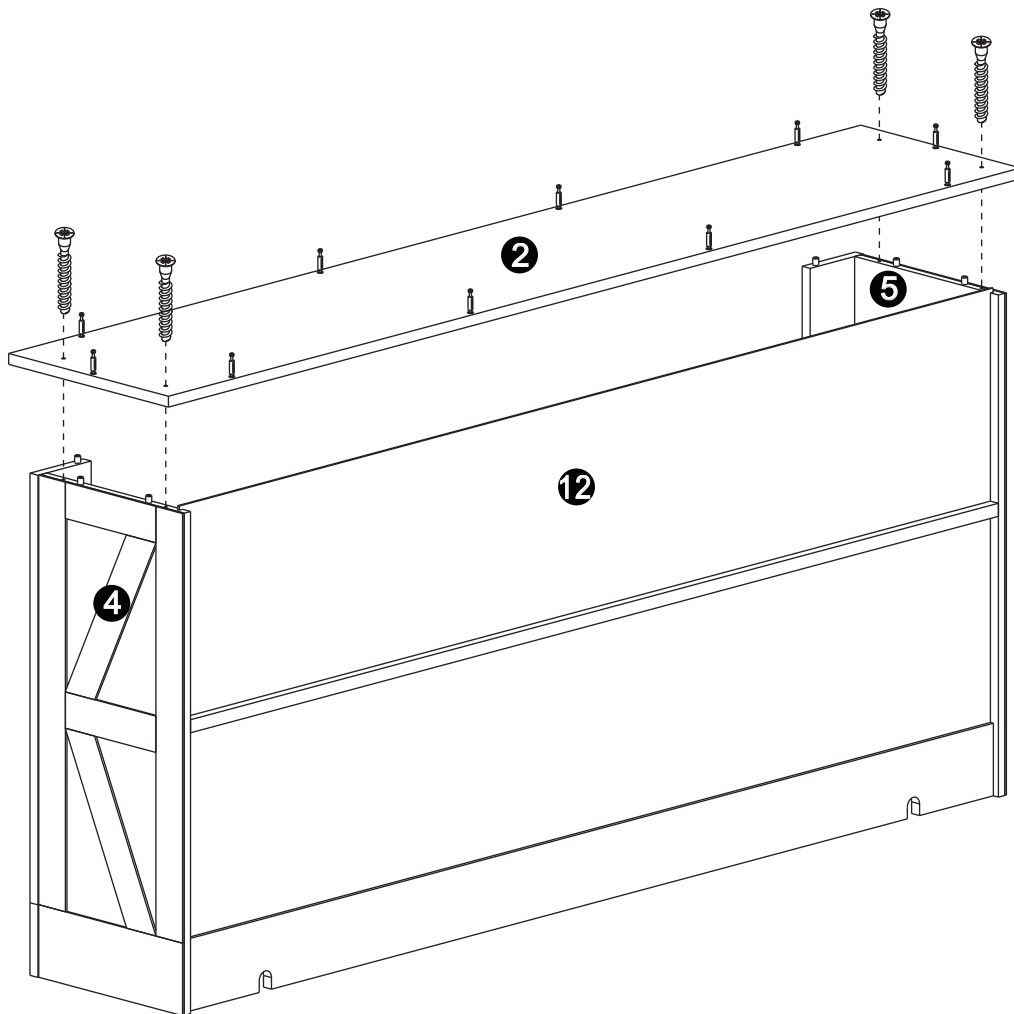

13

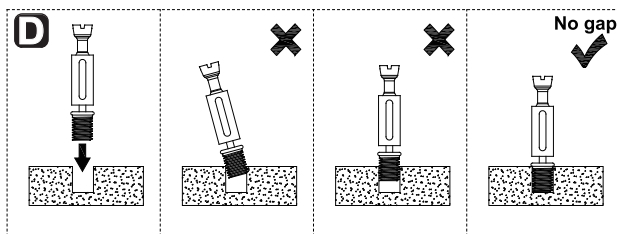

<b>B</b>

5×38mm
4 pcs

14



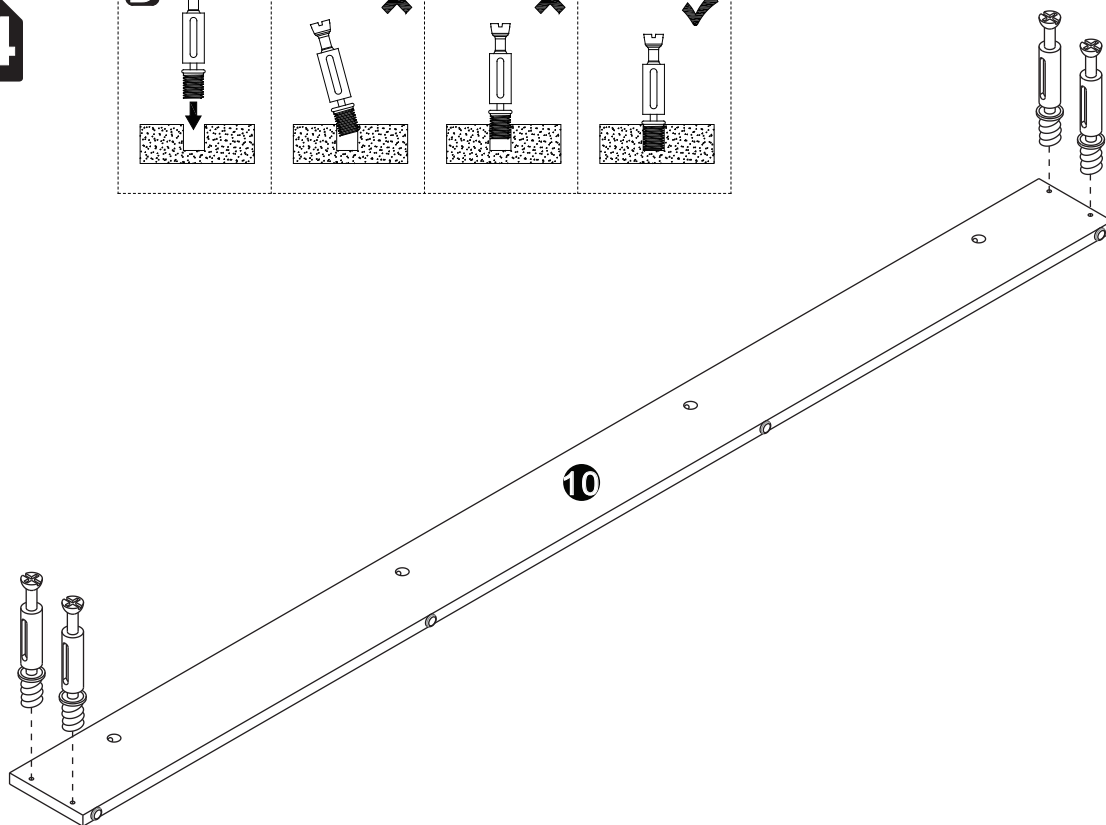

<b>D</b>

M6×44.5mm
8 pcs

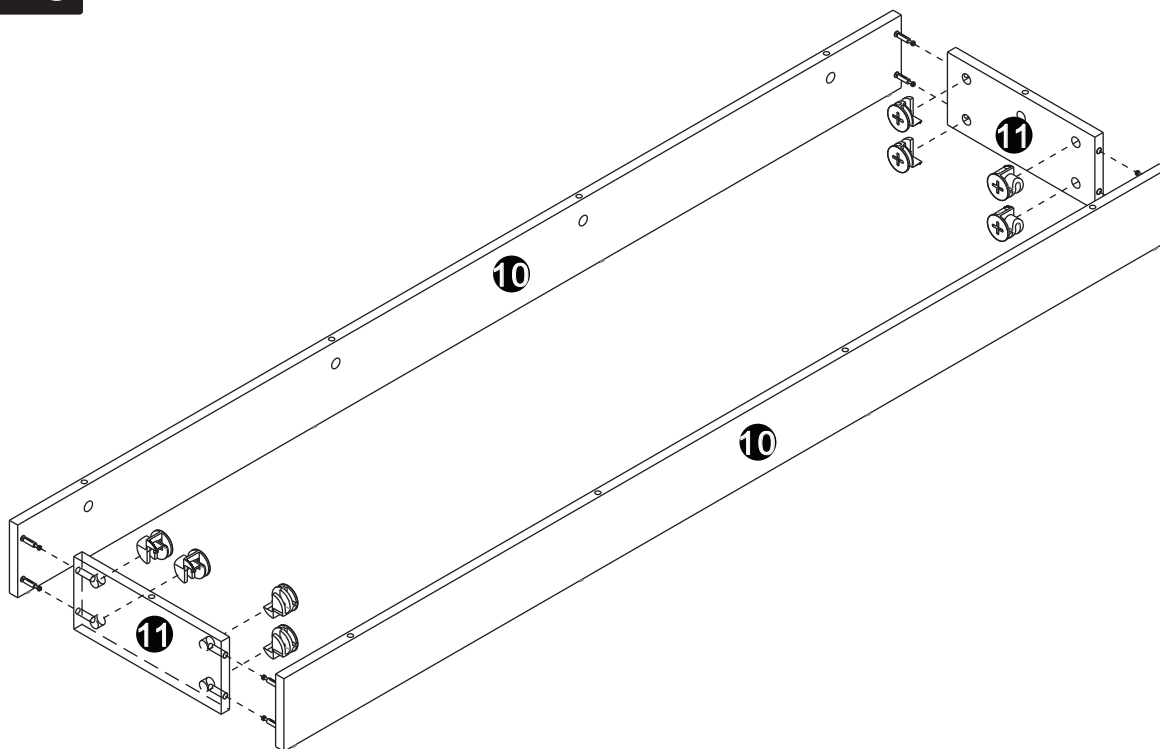

×2

15



<b>E</b>

Ø15mm
8 pcs

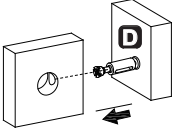
**Step 1**

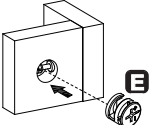

**Step 2**



**Step 3**

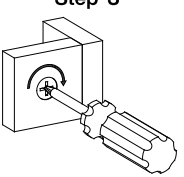

16

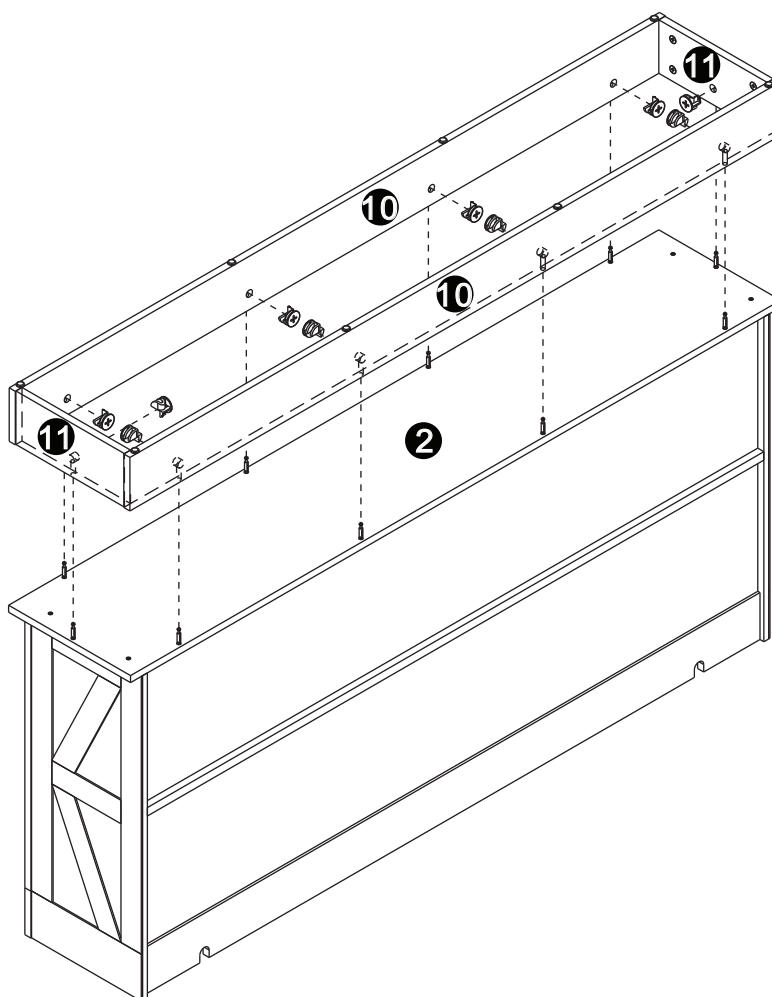

<b>E</b>

Ø15mm
10 pcs

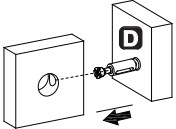
**Step 1**

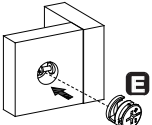

**Step 2**



**Step 3**

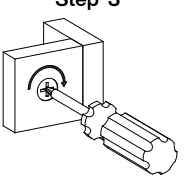

17

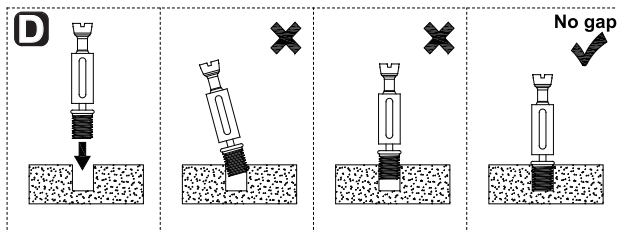

<b>D</b>

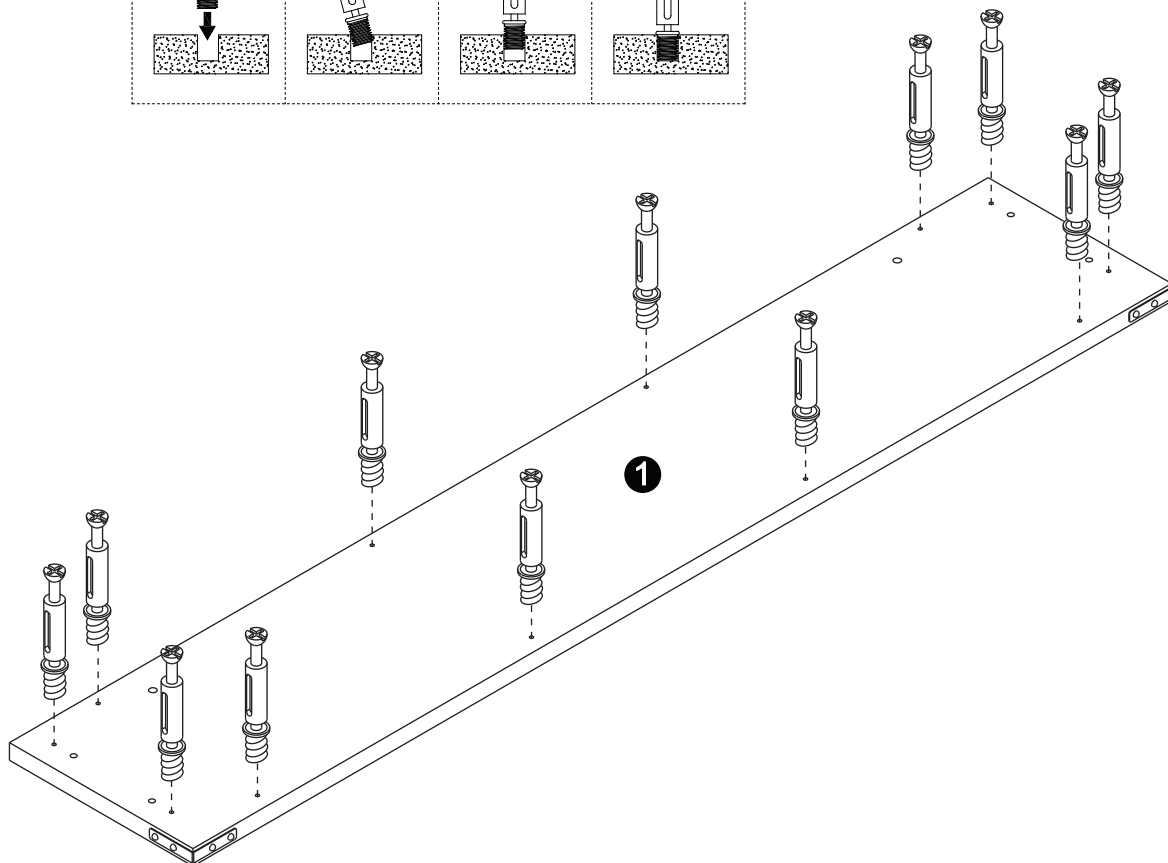
M6×44.5mm
12 pcs

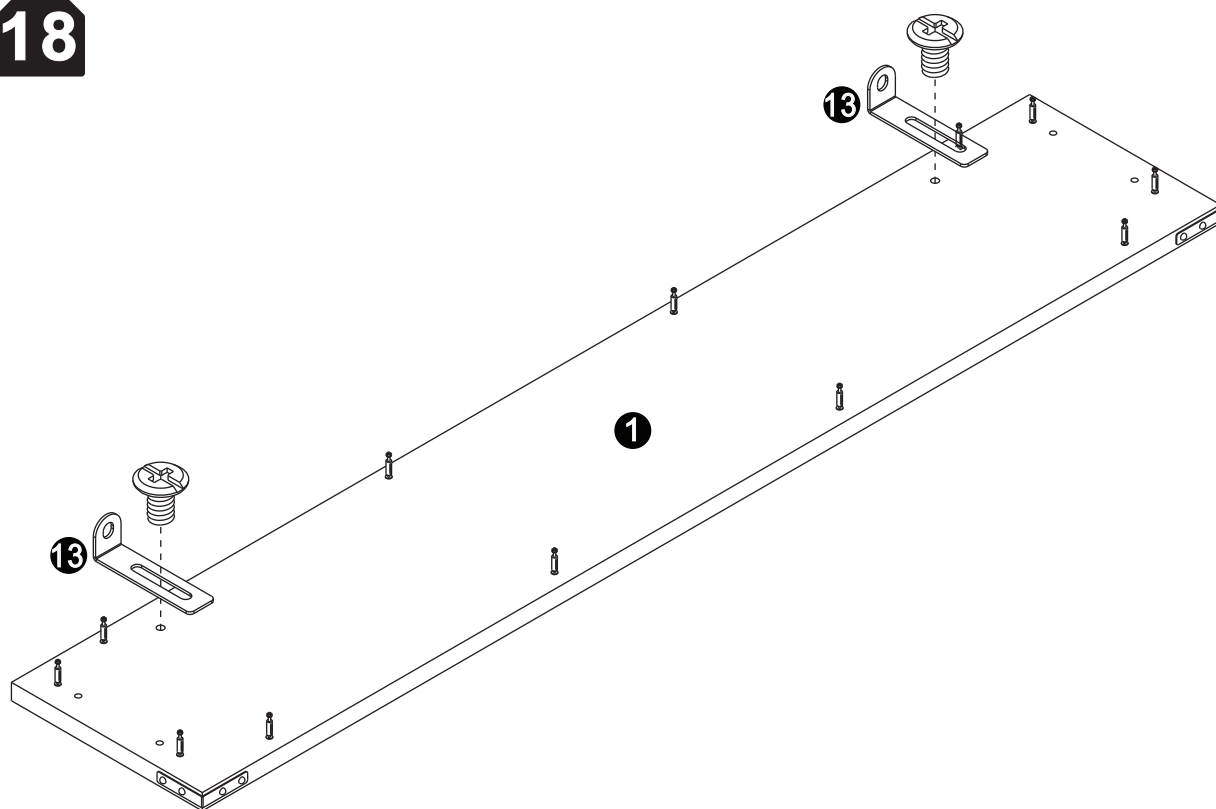

18

<b>A</b>

M6×12mm
2 pcs

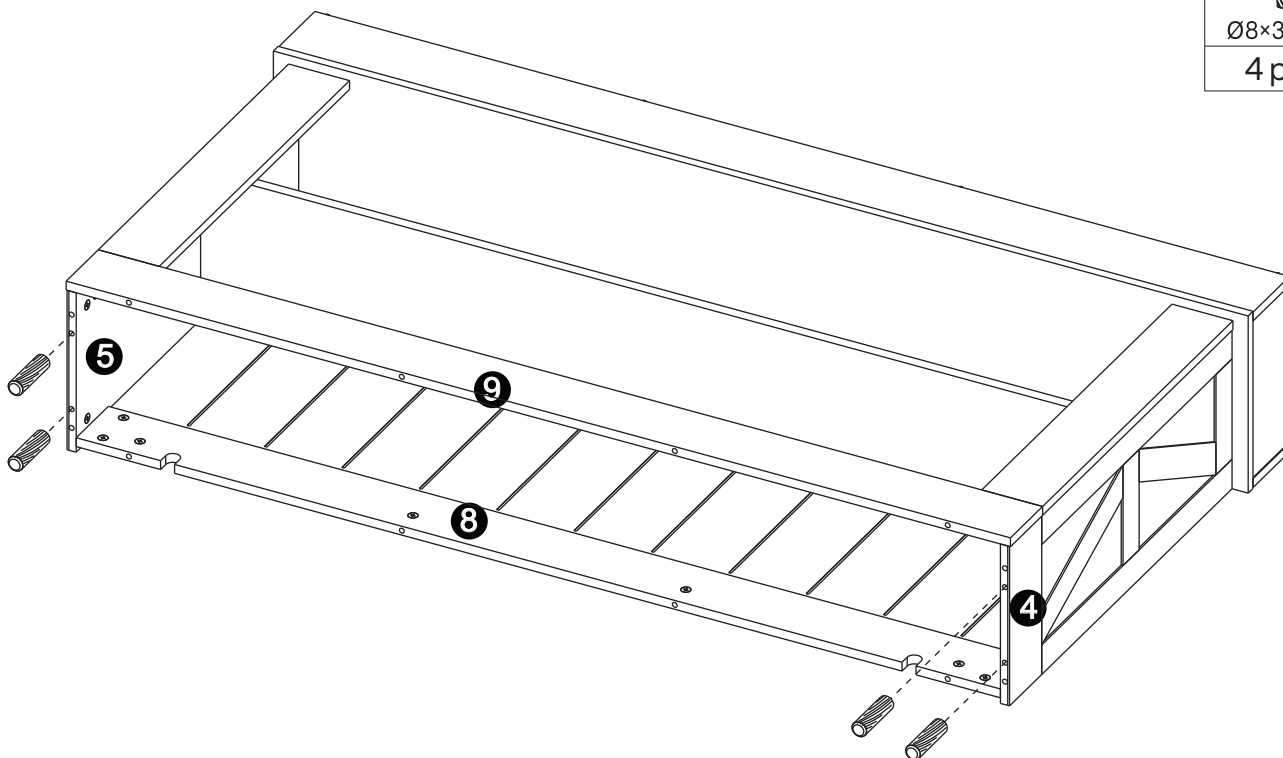

19

<b>C</b>

Ø8×30mm
4 pcs

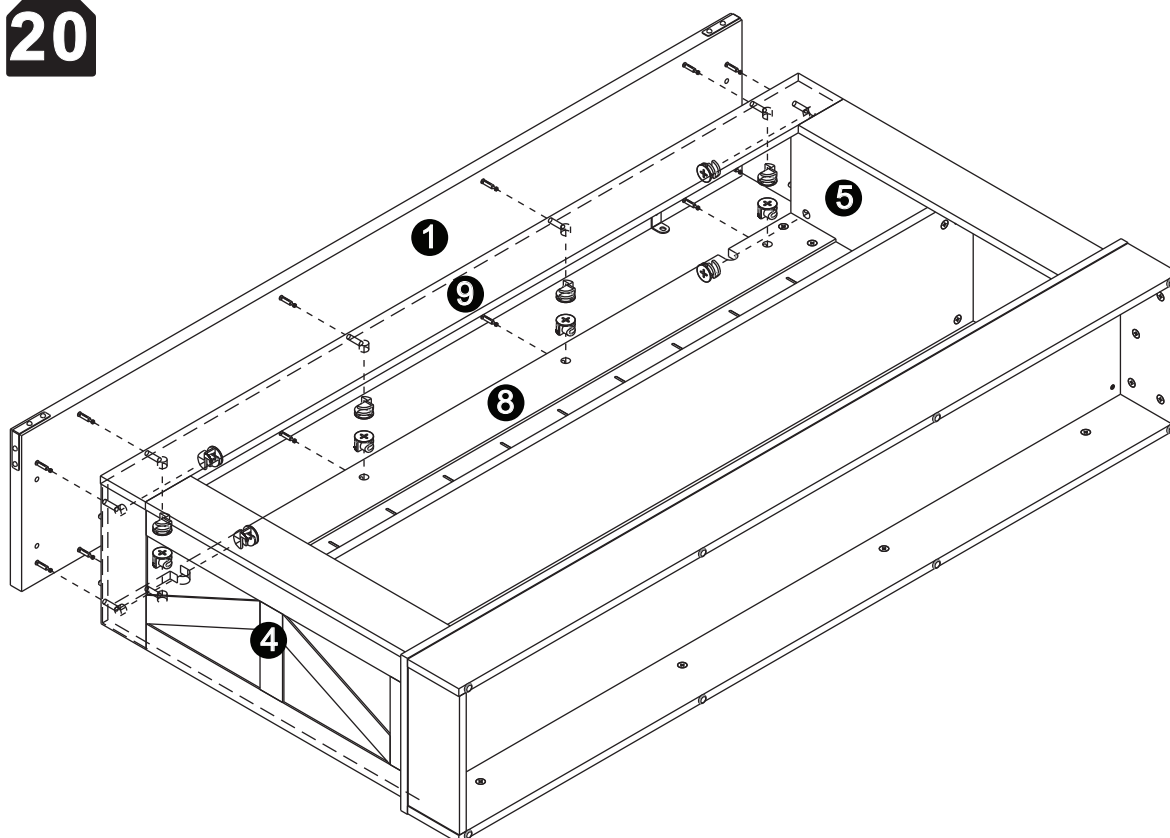

20

<b>E</b>

Ø15mm
12 pcs

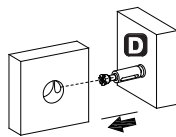

**Step 1**

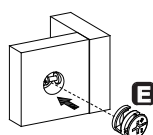

**Step 2**



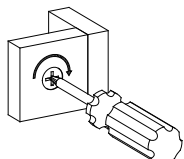

**Step 3**

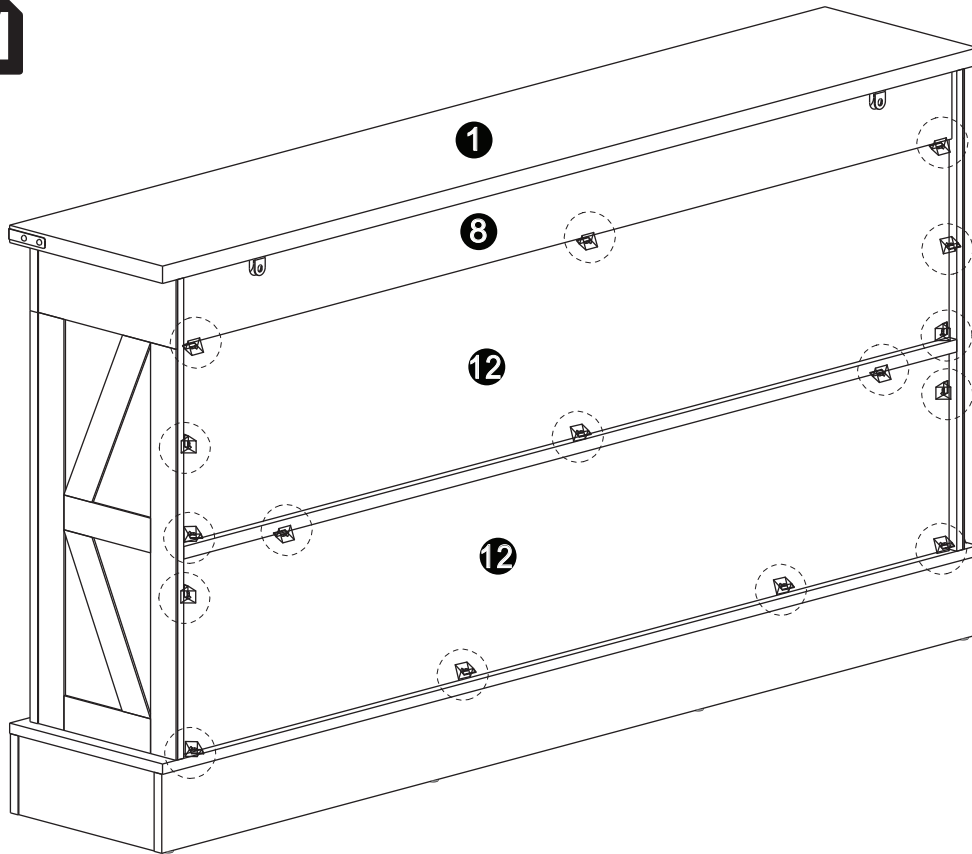

21



F	G
	
16 pcs	3.5x14mm 16 pcs

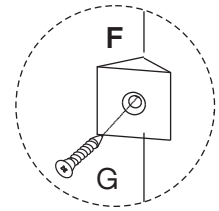
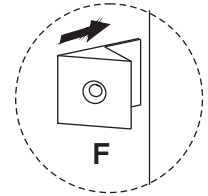

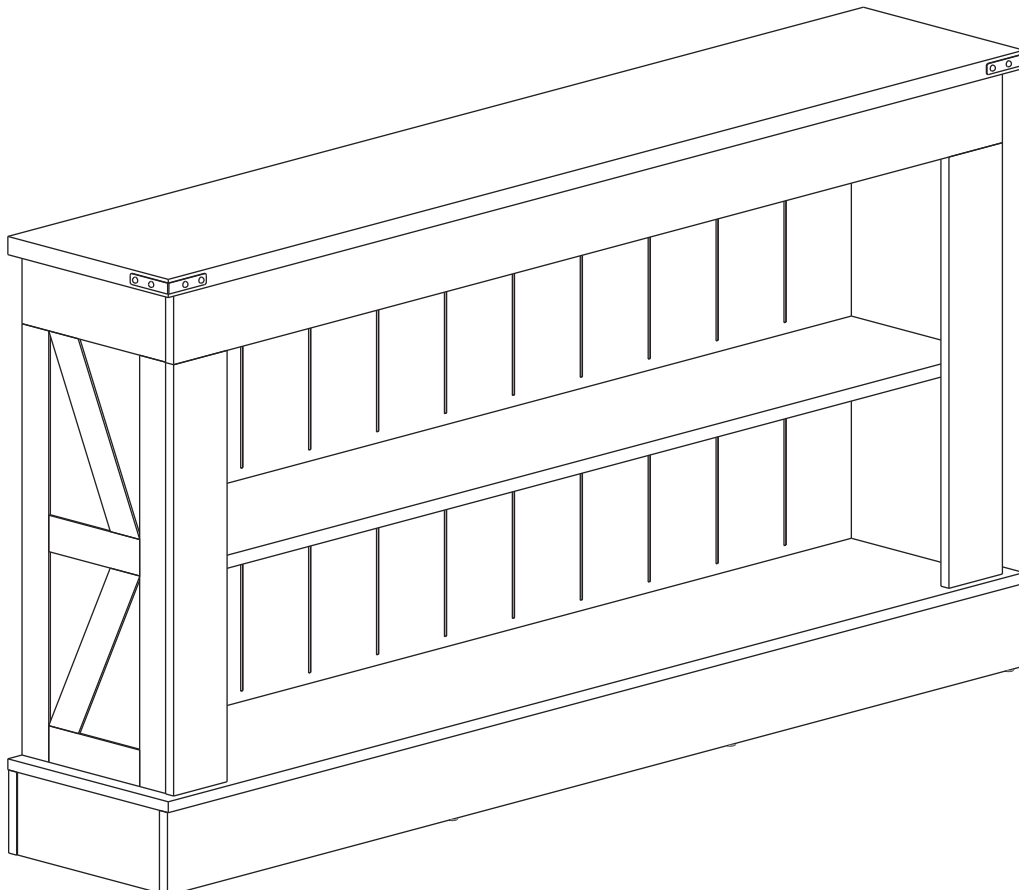

22

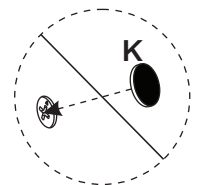

K

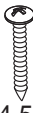
Ø21mm 4 pcs

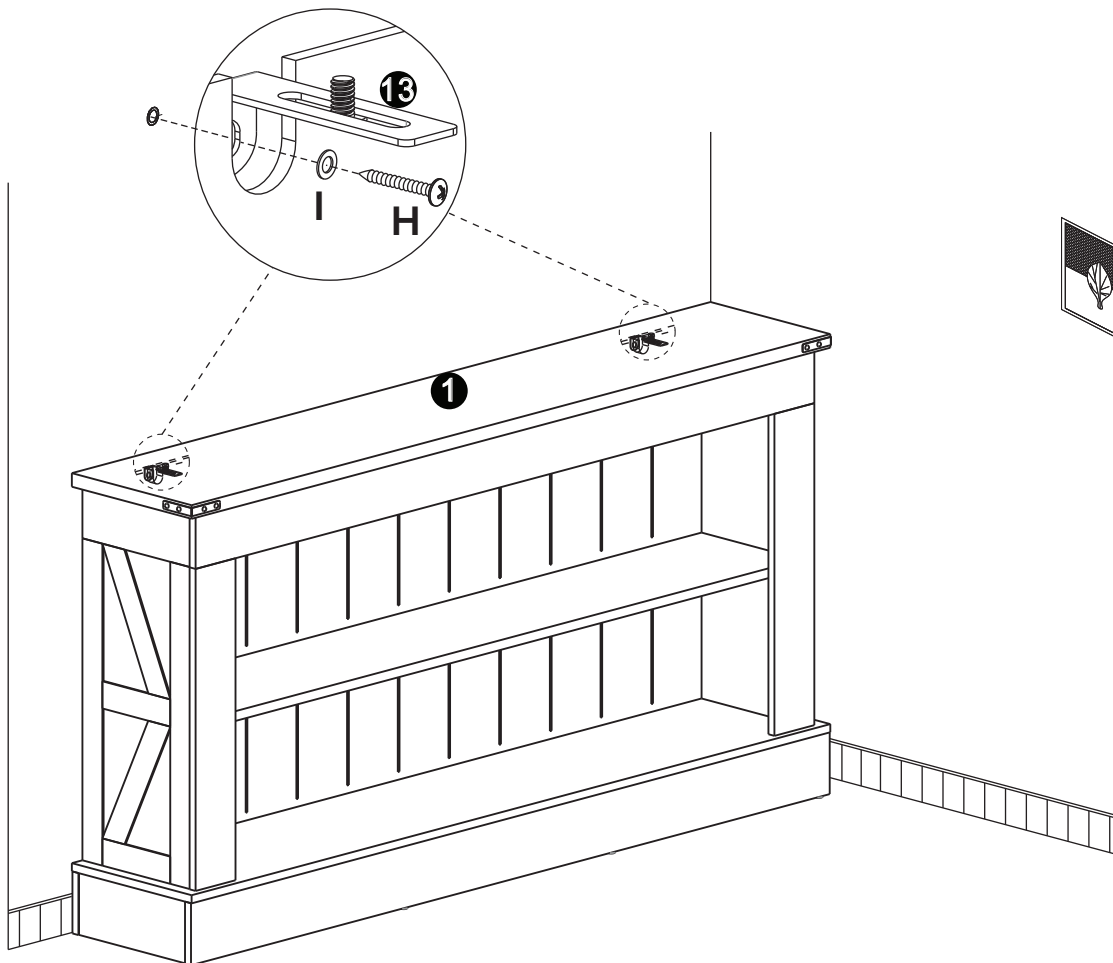
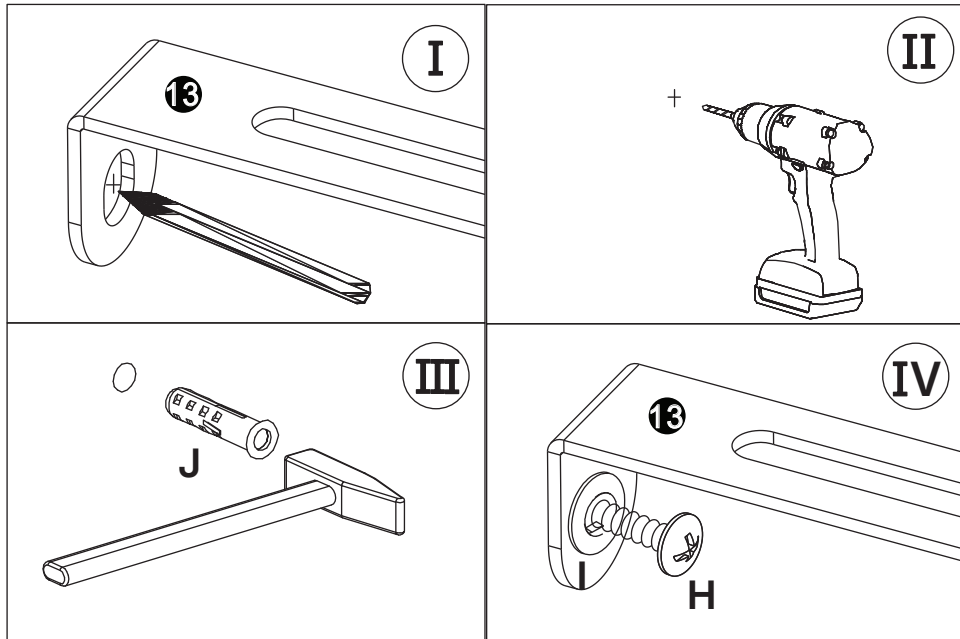

H	I	J
		
4X24.5mm	Ø16XØ6.2mm	
2 pcs	2 pcs	2 pcs



**Thank you for your support!**

