

# ASSEMBLY INSTRUCTIONS

Before assembling your headboard and footboard, please read through these instructions carefully and familiarize yourself with the different parts.

**ATTENTION!** If you receive a damaged or defective item, please contact us

## PARTS LIST

- 1 HEADBOARD PANEL BOARDS 4 PCS
- 2 LEFT LEG 1 PC
- 3 RIGHT LEG 1 PC
- 4 HEADBOARD SUPPORT 1 PC
- 5 FOOTBOARD PANEL BOARDS 3 PCS
- 6 LEFT FOOTBOARD LEG 1 PC
- 7 RIGHT FOOTBOARD LEG 1 PC
- 8 FOOTBOARD SUPPORT 1 PC

Instructions apply for bed sizes  
**FULL > QUEEN**

## HARDWARE

- (A) JCB M6 X 35mm - 28 pcs  
Spare - 1 pc
- (B) JCB M8 X 15mm ( 5/8" ) - 8 pcs
- (C) Wood screw ( 1 1/4" ) - 7 pcs  
Spare - 1pc
- (D) Allen wrench M4 - 1pc  
Spare - 1pc
- (E) Allen wrench M6 - 1pc

NOTE: WE INCLUDE SPARE HARDWARE IN CASE DAMAGE OCCURS DURING ASSEMBLY.

### Step 1

Attach left leg (2) and right leg (3) to headboard panel boards (1) using JCB M6 X 35mm (A). Tighten with the Allen wrench M4 (D).

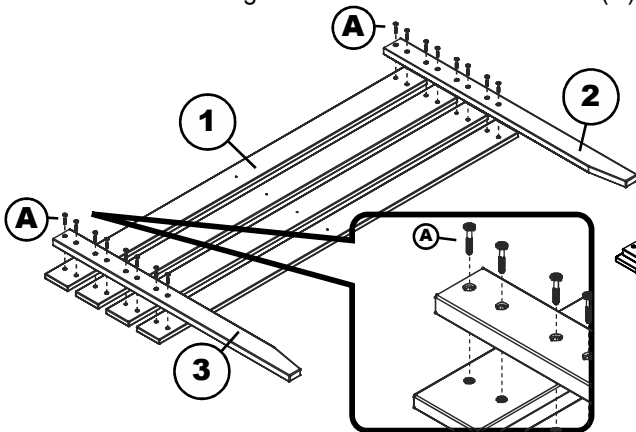

### Step 2

Attach headboard support (4) to headboard panel boards using wood screw 1 1/4" (C). Tighten with the Phillips head screw driver. (Customer supplied)

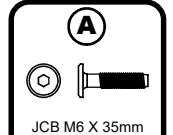
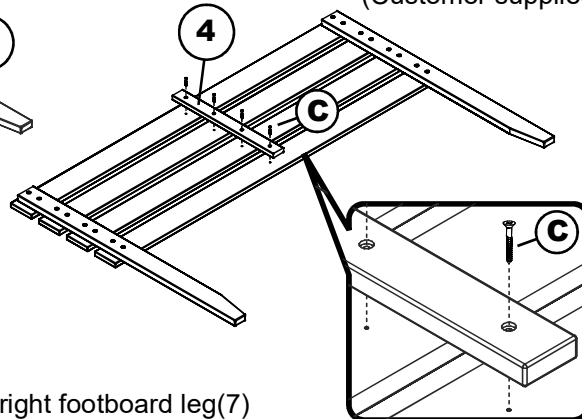

### Step 3

Attach left footboard leg (6) and right footboard leg (7) to footboard panel boards (5) using JCB M6 X 35mm (A). Tighten with the Allen wrench M4 (D).

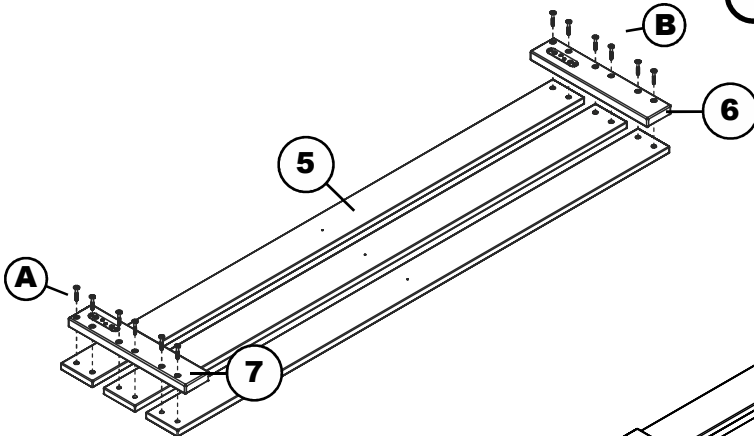

### Step 4

Attach footboard support (8) to footboard panel boards using wood screw 1 1/4" (C). Tighten with the Phillips head screwdriver. (Customer supplied)

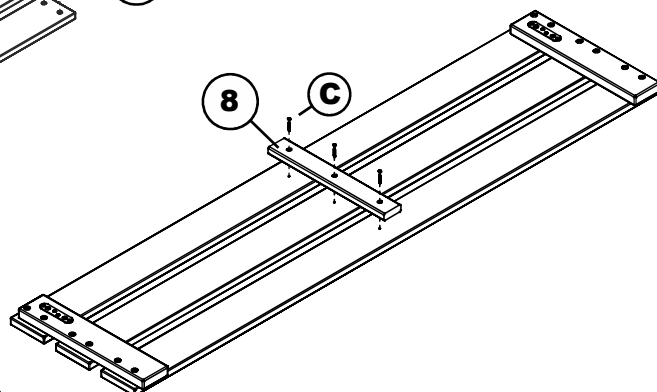

PO:



# BED WITH MATCHING FOOTBOARD

FULL > QUEEN



- 01 HARDWARE
  - 02 HEADBOARD
  - 03 FOOTBOARD
- BOX 1

- 01 HARDWARE
  - 04 SIDE RAILS
  - 05 SLAT KIT
- BOX 2

## Step 1

Attach the side rails (04) to the headboard (02) and footboard (03) using JCB M8 X 15mm (B). Tighten with Allen wrench M6 (E).

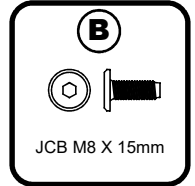
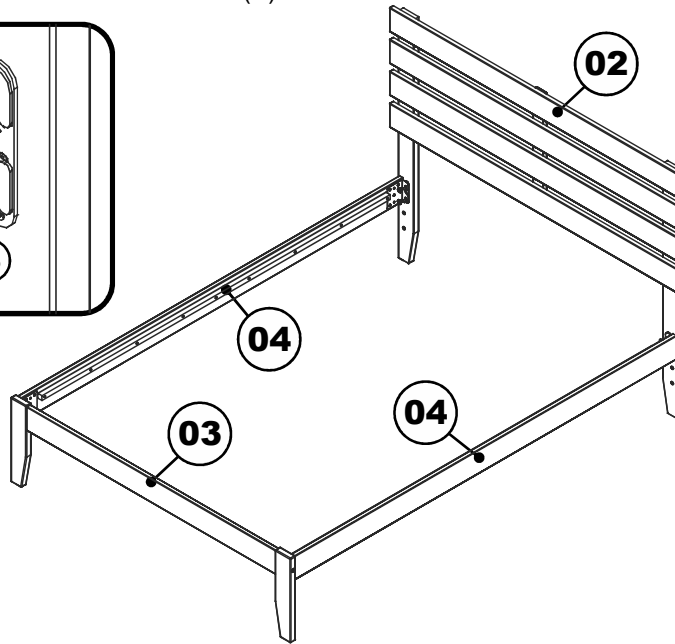
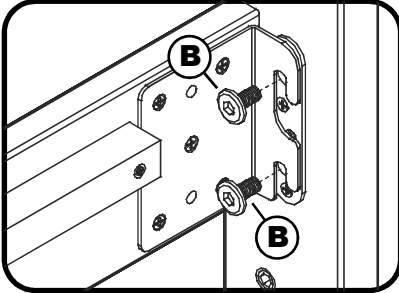

## Step 2

Attach slat kit (05) onto the bed using wood screws. Tighten with Phillips head screw driver. (customer supplied) For assembly of slat kit, follow the assembly instructions included with slat kit.

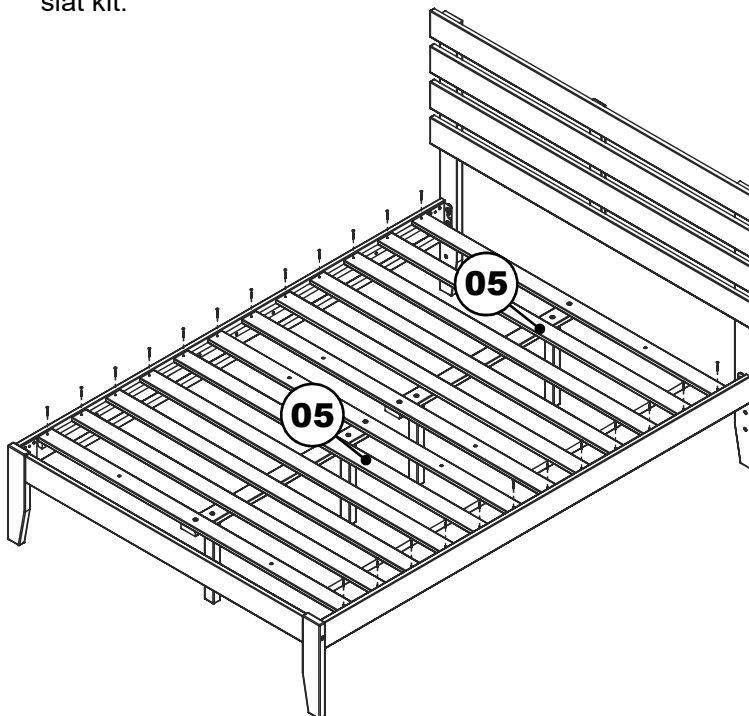

### Congratulations!

Your bed is now ready for use.

We recommend that you periodically recheck that all screws are tight to ensure lasting safety.

# TRUNDLE BED

TWIN

## ASSEMBLY INSTRUCTIONS

Before assembling your Trundle bed, please read through these instructions carefully. Familiarize yourself with the different parts.



**ATTENTION!** If you receive a damaged or defective item, please contact us

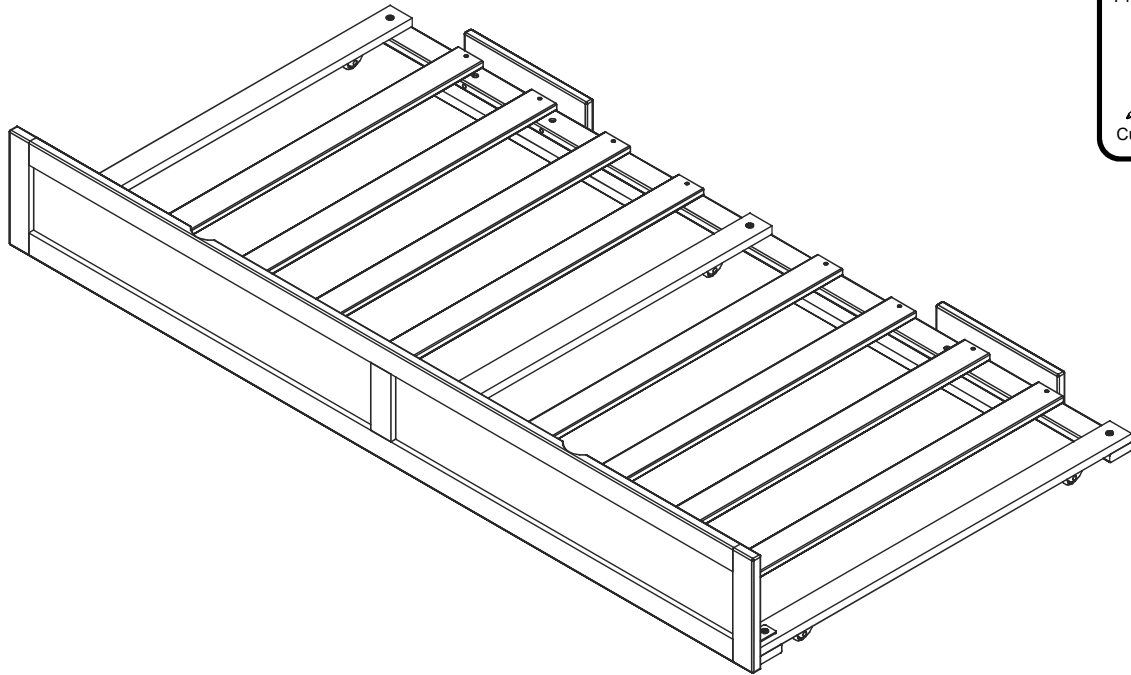

PO : 

## HARDWARE

NOTE: WE INCLUDE SPARE HARDWARE IN CASE DAMAGE OCCURS DURING ASSEMBLY.

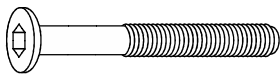

**A** JCB M6 X 2 3/8" ( 60mm ) - 4 pcs  
Spare - 1 pc

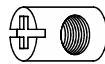

**D** Barrel nut - 4 pcs  
For JCB M6 X 2 3/8"(60mm)

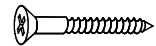

**F** Wood screw - 16 pcs  
Spare - 2 pcs

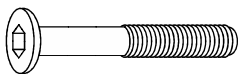

**B** JCB M6 X 1 5/8" ( 40mm ) - 9 pcs  
Spare - 1 pc

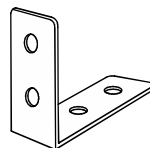

**E** L Bracket - 3 pcs



**G** Allen wrench - 1 pc  
Spare - 1 pc

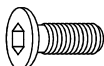

**C** JCB M6 X 5/8" ( 15mm ) - 6 pcs  
Spare - 1 pc  
Fix L bracket to front panel

# TRUNDLE BED

## TWIN PARTS LIST

<b>01</b>	<b>HARDWARE</b>	<b>1 BOX</b>	<b>05</b>	<b>LEFT, RIGHT, MID RAIL</b>	<b>3 PCS</b>
<b>02</b>	<b>FRONT PANEL</b>	<b>1 PC</b>	<b>06</b>	<b>REAR BLOCK</b>	<b>2 PCS</b>
<b>03</b>	<b>FRONT RAIL</b>	<b>1 PC</b>	<b>07</b>	<b>SLAT KIT WITH WEBBING</b>	<b>2 SETS</b>
<b>04</b>	<b>BACK RAIL</b>	<b>1 PC</b>			

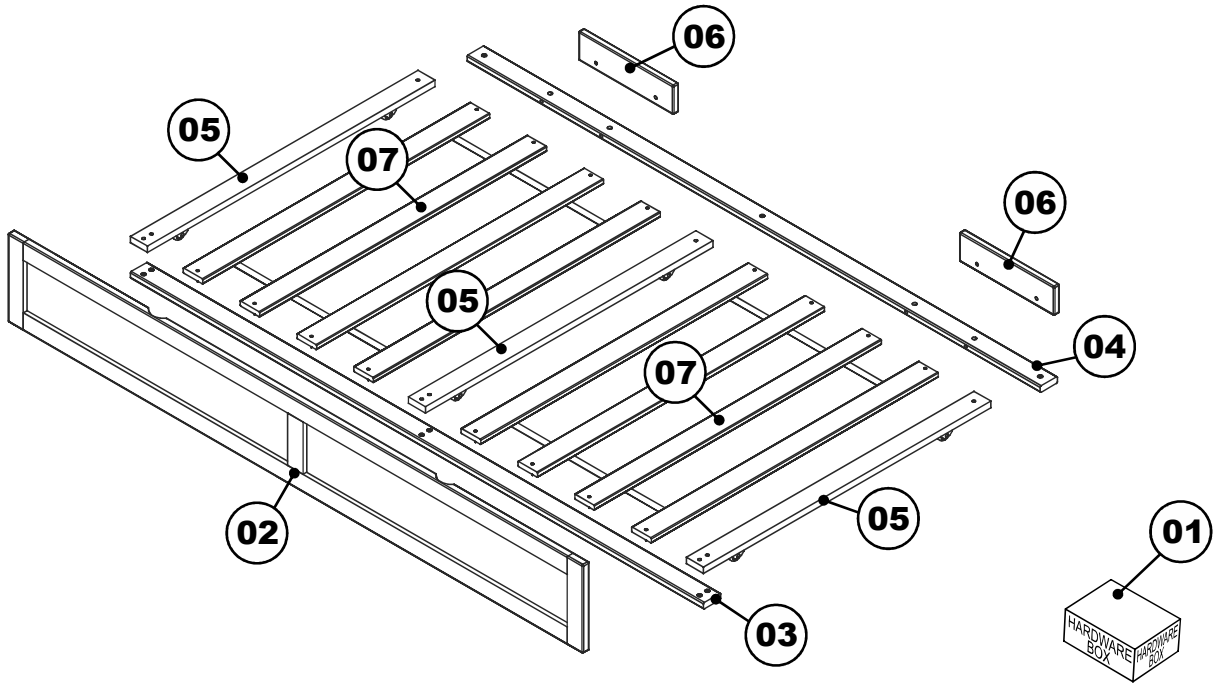

### Step 1

Attach the left, right and mid rails (05) to the front rail (03) using L bracket (E) and JCB M6 X 1 5/8" (B). Attach left, right and mid rails (05) to the back rail (04) using JCB M6 X 1 5/8" (B). Tighten with the Allen wrench (G).

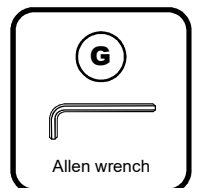
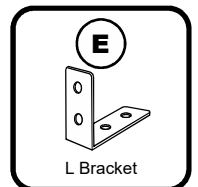
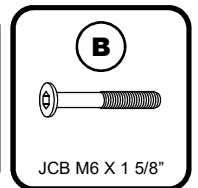
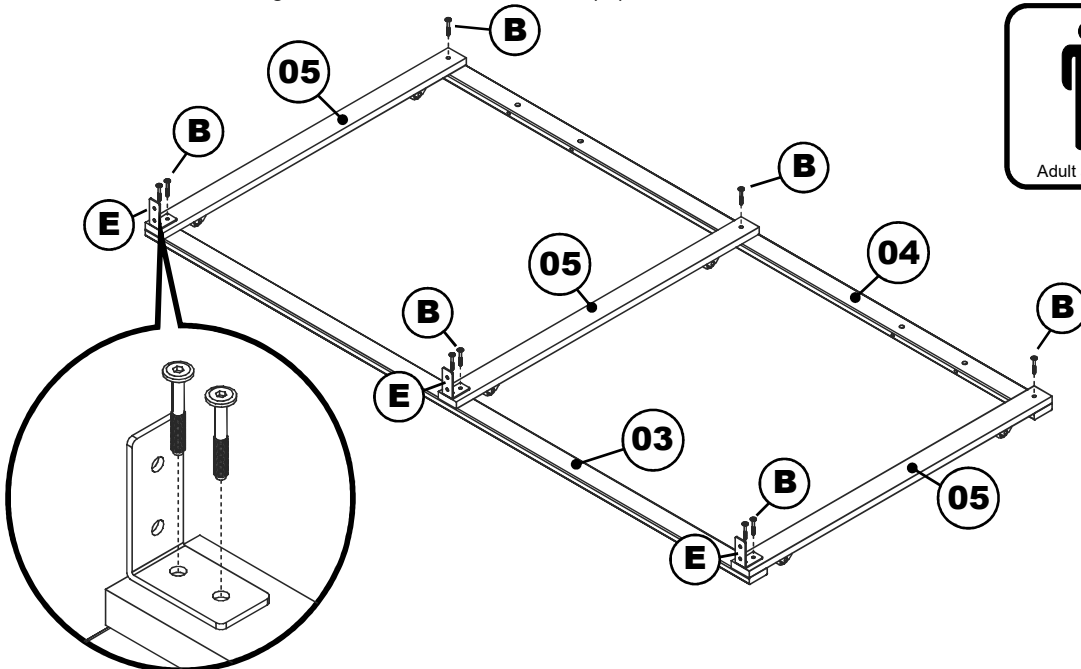

# TRUNDLE BED

## TWIN

### Step 2

Attach the front panel (02) to the front rail (03) as shown, using JCB M6 X 5/8" (C). Tighten with the Allen wrench (G).

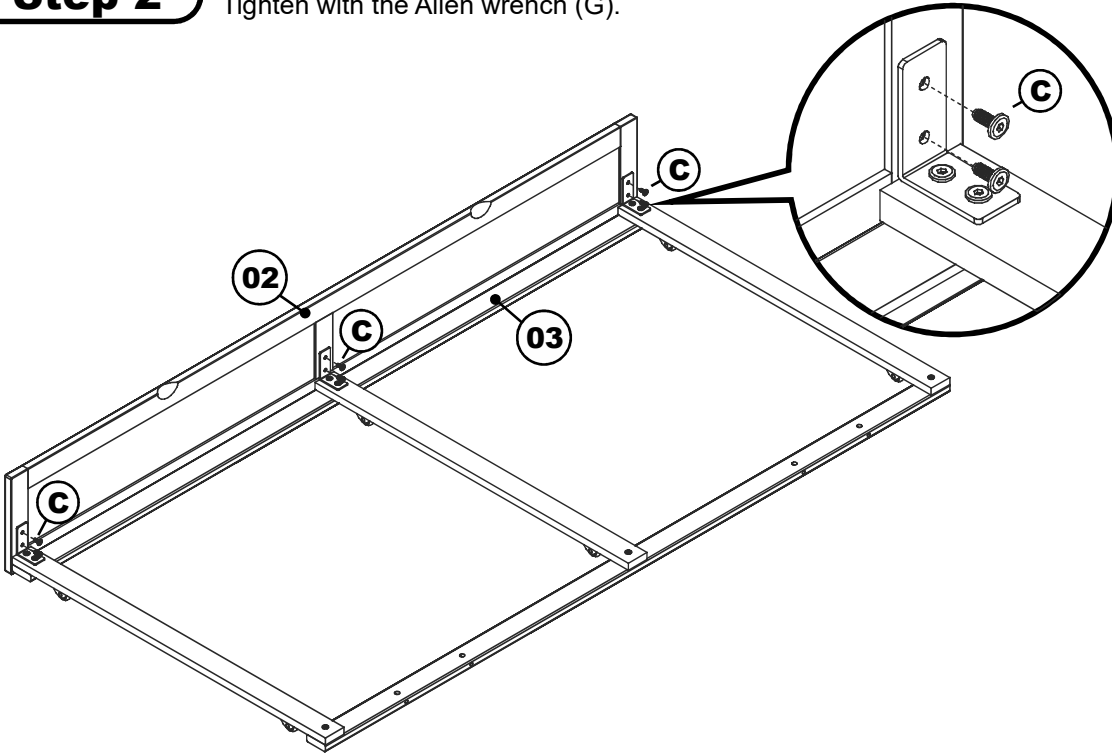

Adult assembly

C



JCB M6 X 5/8"

G



Allen wrench

### Step 3

Lay the slat kits (07) webbing side down onto the rail assembly as shown. Attach using wood screw (F) and tighten with the Phillips head screw driver. (customer supplied)

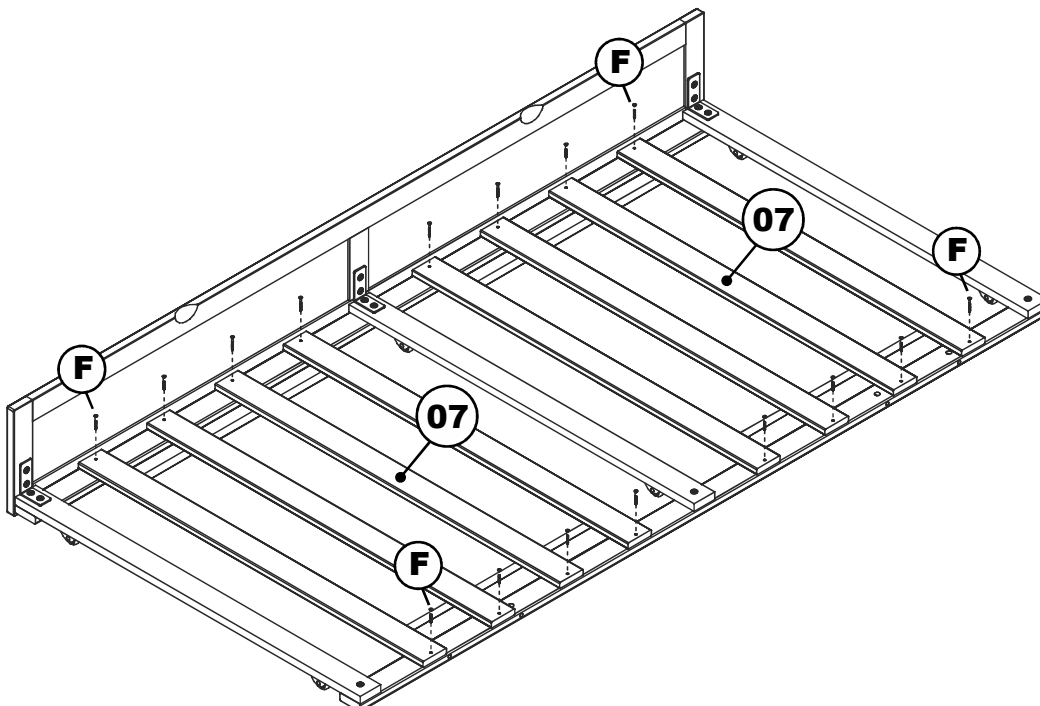

Adult assembly

F

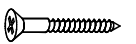

Wood screw

Phillips screwdriver



Customer supplied

# TRUNDLE BED

## TWIN

### Step 4

Attach the rear blocks (06) to the back rail (04) as shown using JCB M6 X 2 3/8" (A) barrel nut (D) Tighten with the Allen wrench (G)

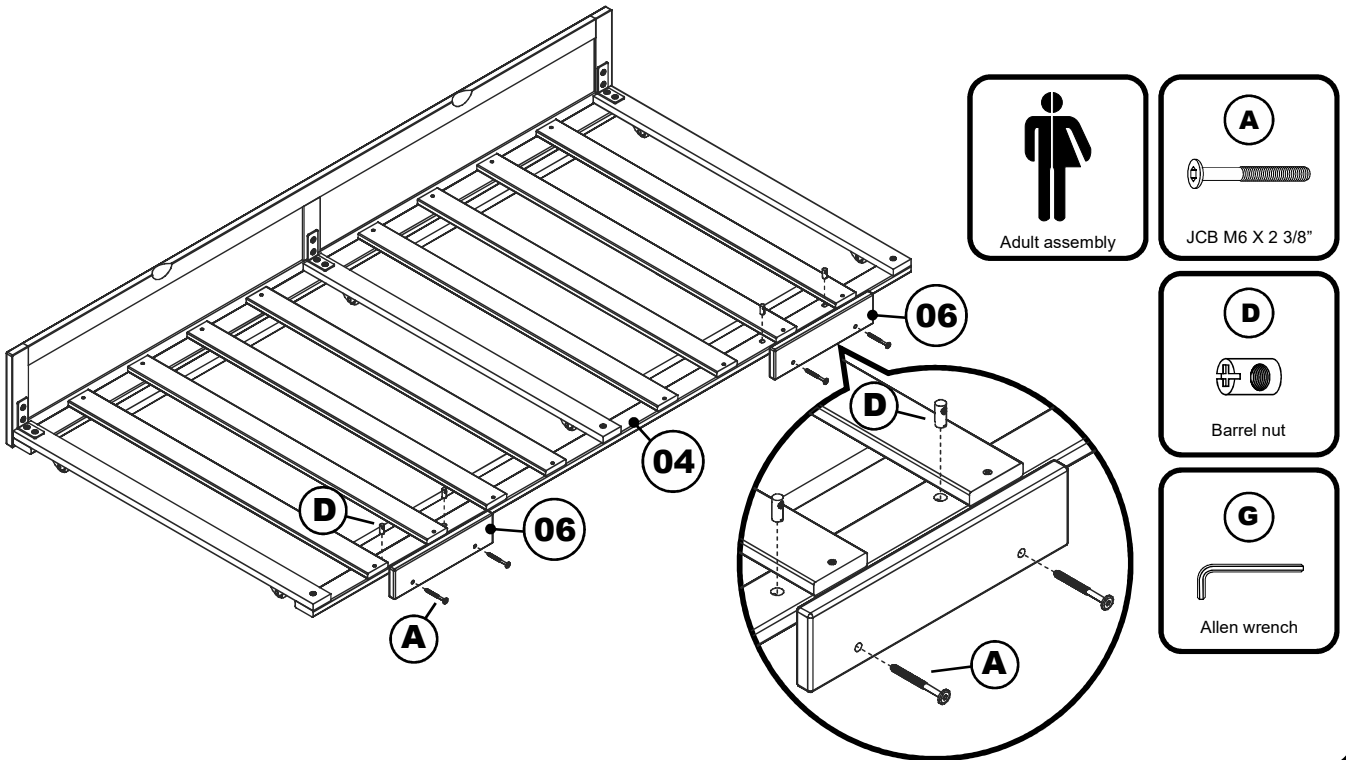

### Step 5

Lastly, Insert Trundle bed to the bed as shown below.

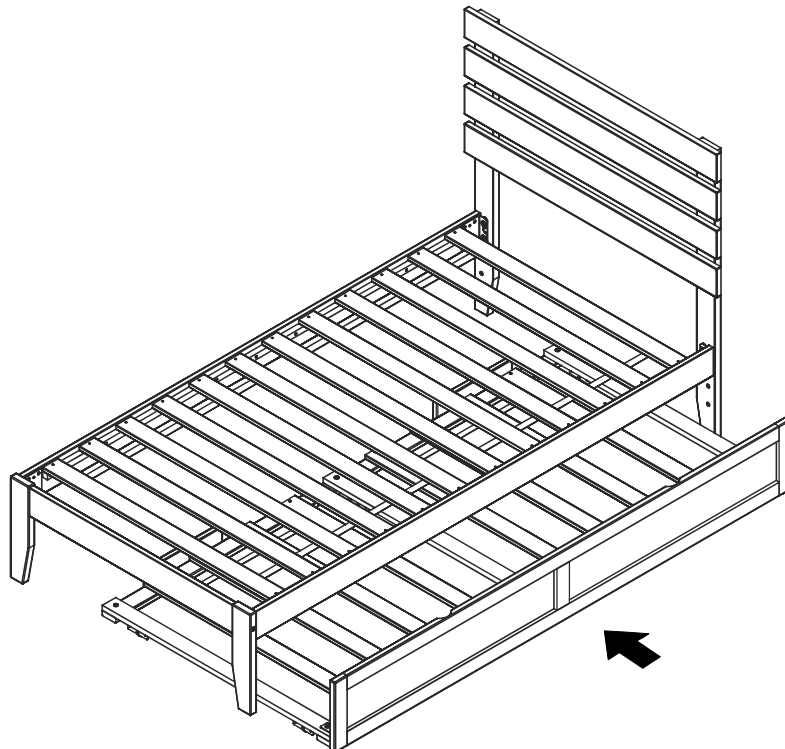

### Congratulations!

Your Trundle bed is now ready for use.  
We recommend that you periodically check that all screws are tight and all parts are secure to ensure lasting safety.