

EN ASSEMBLY MANUAL
PL INSTRUKCJA MONTAŻU



2,5 ~ 3 h

Narutowicza 181
97-500 Radomsko
Poland

e-mail: dsv.dmytro2018@gmail.com

You need to fitting-up :
Niezbędne do montażu :

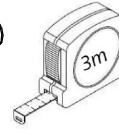
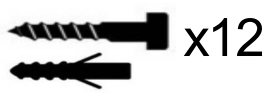
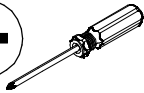
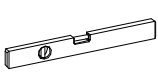

INVENTO

IN-14 Vertical: 160cm - V23032019

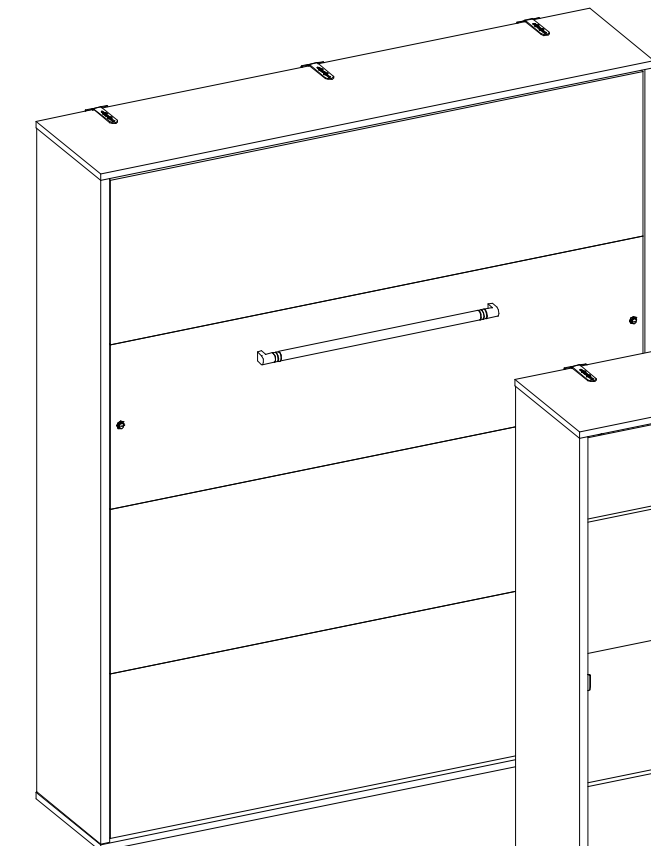
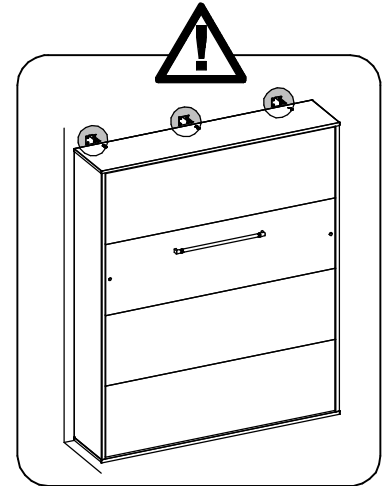

160V 181x220x42 cm

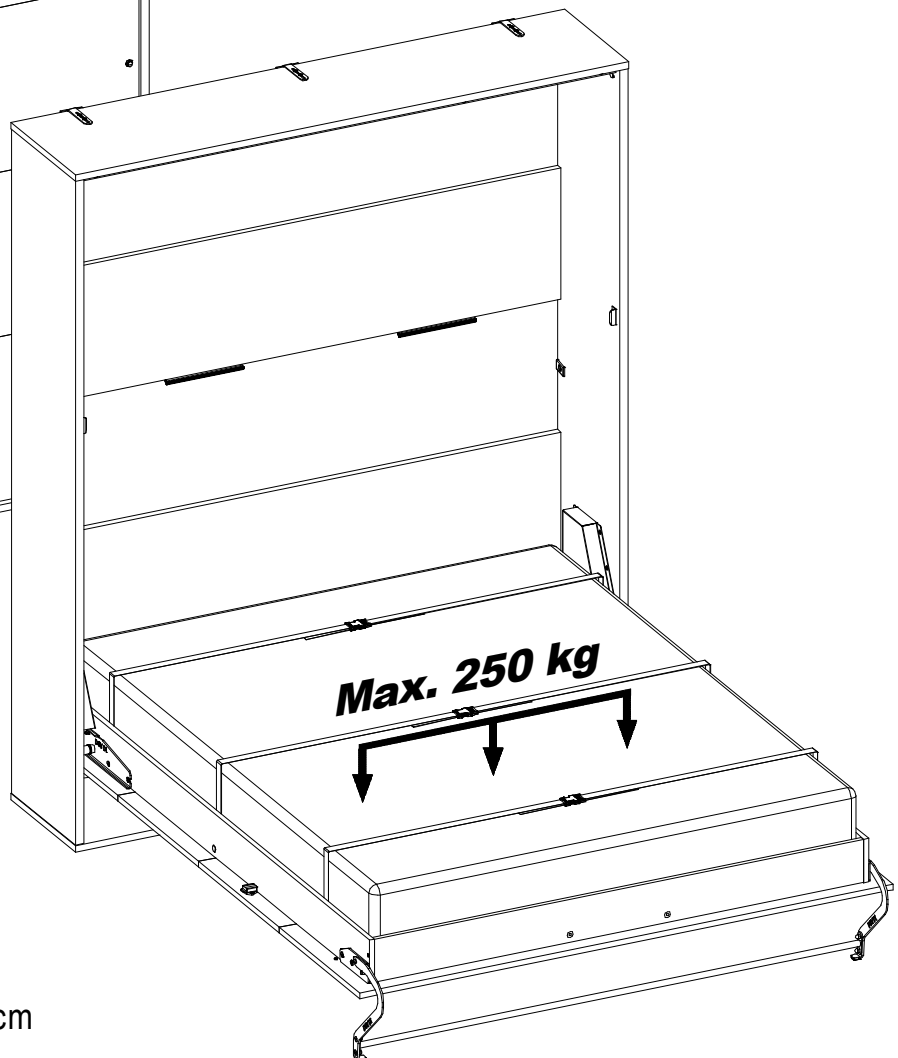

160V 181x220x228 cm

EN Screws dowels for the wall (not included in the delivery). Size and type should be adepcted to the wall consistency.

PL Wkręty i kołki rozporowe do ściany (nie są przewidziane w dostawie). Rozmiar i rodzaj kołków wyznacza się w zależności od typu ściany

EN Before you start the assembly, please get acquainted with the entire assembly manual and stick to the order of assembly presented in this manual.

PL Przed rozpoczęciem montażu należy zapoznać się z całą instrukcją montażu i zachować kolejność montażu przedstawioną w niniejszej instrukcji.

EN Attention!

General Instructions For Furniture Assembly

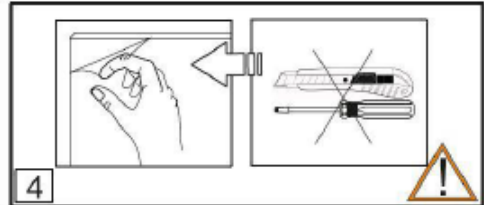
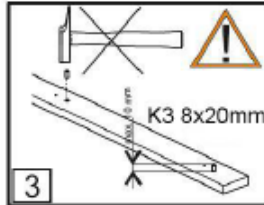
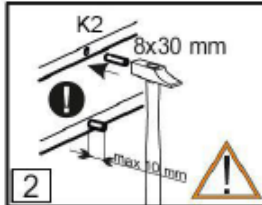
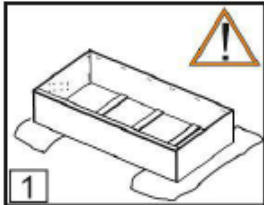

Attention:

1. During the assembly, the elements should be put on a soft and clean surface, e.g. a towel or a blanket. Do not assemble the piece on a carpet or floor covering, etc.
2. Drive "K2" pegs into the holes (8 mm in diameter) located along the edges of each element (leave the holes for the eccentric connector pivot free). Attention: In case a peg in one of the holes protrudes more than 10 mm, it may cause damage to the side of the piece of furniture during its assembly.
3. Please insert the pegs "K3" by hand into Part Nr.07.21.
4. Please remove the front protective film by the hand!
Don't use any tools!

INFORMATION!

1. Dear customer, in the case of a complaint, please use the part number / letter of the assembly instructions. If you find any damage or scratching before the assembly, please send us the picture. Note! Do not assembly any parts showing any faults or marks of damage.
2. Any comments and complaints should be reported at the furniture purchase outlet.
3. Before of start the assembly, please get acquainted with the entire assembly manual and stick to the order of assembly presented in this manual.
4. The function of the sleep position preparation should not exercised by a child under 12 years.
5. The non-wall-mounted bed is not stable!
6. The INVENTO bed can only be opened after attaching the gas springs and mounting to the wall.
7. We reserve the rights to make technical changes and changes in the assembly instructions as our products are subject to continual improvement and developments.
8. The producer reserves the right for technical innovation and is not obliged to inform the customers about this change in advance. The quantity of supplied parts may at times differ from the amount shown in the assembly instructions. Please contact in this case the seller .
9. DSV DI is not responsible for any damage, due to the improper assembly of the INVENTO wallbed, the usage of inappropriate fixing material, the mounting on therefor suitable subsoil, the non-observance of this assembly manual or the non-intended usage of this product.

Important to note!!!

1. The customer should only be entitled to warranty claims if the defect is present before the assembly and the furniture's part is photographed with the defect in a disassembled state.
 2. If the images are to be made after assembly, the claim can be rejected and the buyer is no longer entitled to claim and may also require a paid claim.
- Assembly instructions, fittings, slatted frame, screws and hardware.
Before assembly, please check all the screws.

PL Uwaga!

Ogólne instrukcje dotyczące montażu mebli

Uwaga:

1. Podczas montażu elementy należy układać na miękkim i czystym podłożu np.: ręcznik, koc. Nie montować mebla na dywanie, wykładzinie itp.
2. W otwory o średnicy 8 mm znajdujące się w krawędziach elementów wbić kołki K2 (Otwory na trzpień z łączą mimośrodkowego pozostawić wolne). W przypadku stwierdzenia, że któryś z kołków wystaje z otworu na długość większą niż 10 mm, należy go dobić, wymienić, lub skrócić, gdyż może on spowodować uszkodzenie boku przy składaniu.
3. Kołki "K3" do elementu Nr.07.21. włożyć ręcznie
4. Folię zabezpieczającą front zdejmować ręcznie!
Nie używać narzędzi!

INFORMACJA!

1. Drogi kliencie, w przypadku reklamacji prosimy użyć numeru elementu/oznaczenia w instrukcji montażu. Prosimy o przesłanie zdjęcia w razie zauważenia jakichkolwiek uszkodzeń lub zadrapań przed montażem. Uwaga! Nie montować elementów, jeśli zostaną zauważone wady lub uszkodzenia tych elementów.
2. Wszelkie uwagi i skargi należy zgłaszać do punktu sprzedaży mebli.
3. Przed przystąpieniem do montażu prosimy zapoznać się z całą instrukcją montażu oraz zasadami konserwacji i użytkowania mebla. Należy zachować kolejność poszczególnych etapów montażu z uzgodnieniem paragrafów zawartych w danej instrukcji.
4. Łóżko w szafie INVENTO nie jest przeznaczone do użytku przez dzieci poniżej 12 lat.
5. Brak lub niewłaściwe zamocowanie mebla do ściany grozi przewróceniem (zerwaniem) podczas montażu bądź użytkowania mebla. Przed zamocowaniem mebla do ściany należy sprawdzić czy ściana nadaje się do mocowania do niej mebli, dobrać odpowiedni kołek, sprawdzić siłę i jakość zamocowania.
6. Łóżko INVENTO może otwierać się dopiero po zamontowaniu sprężyn gazowych i zamocowaniu do ściany.
7. Zastrzegamy sobie prawo do wprowadzania zmian technicznych i zmian w instrukcjach montażu, ponieważ nasze produkty podlegają ciągłemu doskonaleniu i rozwojowi.
8. Producent zastrzega sobie prawo do innowacji technicznych i nie jest zobowiązany do wcześniejszego informowania klientów o tej zmianie. ilość dostarczonych części może czasami różnić się od ilości podanej w instrukcji montażu. Skontaktuj się w tym przypadku ze sprzedawcą.
9. Firma DSV DI nie ponosi odpowiedzialności za jakiegokolwiek uszkodzenia spowodowane niewłaściwym montażem łóżka w szafie INVENTO, użyciem nieodpowiedniego materiału mocującego, nieprzestrzeganiem niniejszej instrukcji montażu lub niewłaściwym użytkowaniem mebla.

Ważne!!!

1. Klient ma prawo do roszczeń gwarancyjnych tylko wtedy, gdy wada elementu została zauważona przed montażem, a wadę elementu utrwalono na zdjęciu.
2. Jeśli zdjęcia wykonane zostaną po złożeniu mebla, roszczenie może zostać odrzucone, a kupujący nie ma już prawa do roszczenia. Klient może wymagać płatnego roszczenia
Instrukcja montażu, okucia, stelaż, śruby i elementy konstrukcyjne.
Przed montażem sprawdzić okucia.

EN**SAFETY INSTRUCTIONS:**

- Furniture should be used for their intended purpose.
- Furniture should be used in dry, closed rooms, protected from an adverse weather and a direct sunlight .
- Furniture should not be set at a distance of less than half a meter of active radiators.
- The equal leveling is required and the need to set furniture on the stable base .
- Wet objects should not be placed on surfaces of furniture.
- To prevent the piece of furniture from falling over, please attach it permanently to the wall. Check the type and strength of the wall. Choose the appropriate screws and dowels for the wall. Ultimately it is the person carrying out the installation who is responsible for attachment to the masonry.

**Maintenance**

After one year, check all screw connections, wall mounting and gas pressure springs.

DIRECTIONS FOR PROPER USAGE OF FURNITURE :

In order to directions use a soft, dry duster to dust furniture. If furniture needs more precise polishing use a wet duster, after that wipe furniture until it's dry. Metal and glass parts of furniture polish with any available detergents to get former gloss. After that wipe the metal parts with a dry duster. Glass parts wipe with a paper towel

Warning!

Never use a sharp scrubbing cleaners, detergents, solvents. Use only soft and tested cleaning for furniture.

CARE INSTRUCTIONS FOR HIGH GLOSS SURFACES OF FURNITURE:

- Our high gloss surfaces have a protective foil when delivered. Please leave this foil on the furniture until it is completely assembled and all dust has been removed.
- To maintain the valuable high gloss appearance, you should
- expose the high gloss foil to the room air for 12 hours to allow it to harden after removing the protective foil
 - only use a damp cotton cloth and a small amount of glass cleaner to clean the surfaces
 - do not use any sharp cleaners with additives
 - rub off the surfaces with a wet rag
 - do not use a steam cleaner
 - do not damage the surface with sharp objects
 - do not expose the surfaces to intense sunlight in any case.

Dear customer, if any part is missing or damaged, mark it on the assembly instruction and sent it together with pictures and the claim please. If the damaged item is permanently mounted, than the complaint will not be recognized.

We wish you plenty of enjoyment with our furniture !

PL**INSTRUKCJE BEZPIECZEŃSTWA:**

- Meble powinny być używane zgodnie z ich przeznaczeniem
 - Meble powinny być używane w suchych, zamkniętych pomieszczeniach, chronione przed niekorzystną pogodą i bezpośrednim nasłonecznieniem.
 - Meble nie powinny być ustawione w odległości mniejszej niż pół metra od grzejników.
 - Wymagane jest równe ustawienie mebla oraz konieczność zabudowy na stabilnym podłożu.
 - Nie umieszczać mokrych przedmiotów na powierzchni mebla.
 - Aby zapobiec przewróceniu mebla, należy przymocować go na stałe do ściany. Przed zamocowaniem należy sprawdzić rodzaj i wytrzymałość ściany.
- Dobrać odpowiednie śruby i kołki do ściany. Osoba wykonująca montaż odpowiada za mocowanie mebla do ściany.

**Konserwacja**

Po roku użytkowania łóżka w szafie sprawdzić wszystkie połączenia śrubowe, montaż ścienny oraz sprężyny gazowe.

SPOSÓB PRAWIDŁOWEGO UŻYTKOWANIA MEBLI:

Powierzchnię mebla można czyścić specjalną szmatką do kurzu. Jeśli meble wymagają bardziej precyzyjnego czyszczenia, użyć wilgotnej ściereczki, a następnie wytrzeć meble aż do wyschnięcia. Aby uzyskać pierwotny błysk metalowych i szklanych elementów można użyć specjalnej pasty do czyszczenia. Następnie przetrzeć metalowe części suchą ściereczką. Szklane części wytrzeć ręcznikiem papierowym.

Uwaga!

Nigdy nie używaj ostrych szorujących środków czyszczących, detergentów, rozpuszczalników. Używaj tylko sprawdzonych, miękkich środków przeznaczonych do mebli.









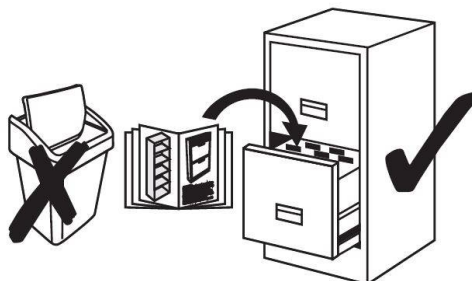

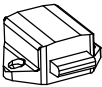

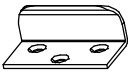

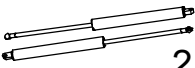



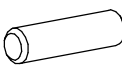





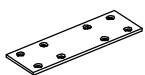

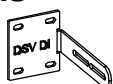
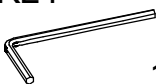
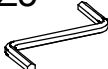

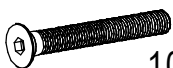





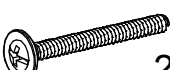

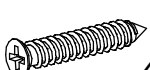

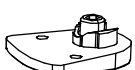
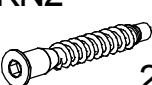







INSTRUKCJE DOTYCZĄCE PIELĘGNACJI POWIERZCHNI W WYSOKIM POŁYSKU:

- Nasze powierzchnie o wysokim połysku są fabrycznie ochronione specjalną folią ochronną. Prosimy pozostawić ją na meblach do momentu zmontowania i usunięcia kurzu. Aby uzyskać wysoki połysk, należy:
- po usunięciu folii ochronnej pozostawić folię połyskową przez 12 godzin w pomieszczeniu do stwardnienia
 - stosować do czyszczenia wyłącznie bawełnianą szmatkę i odrobinę środka do mycia szkła
 - nie stosować ostrych środków czyszczących z dodatkami
 - ściierać powierzchnie wilgotną szmatką
 - nie stosować myjki parowej
 - nie uszkodzić powierzchni ostrymi przedmiotami
 - w żadnym wypadku nie narażać powierzchni na mocne promieniowanie słoneczne.

Drogi kliencie, jeśli jakiegokolwiek elementu brakuje lub jest on uszkodzony, prosimy zaznaczyć go na instrukcji montażu i przesłać do nas zdjęcie oraz reklamację. Jeśli uszkodzony element został już zamontowany, reklamacja nie będzie uznana.

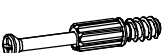
Życzymy dużo radości z użytkowania naszych mebli!

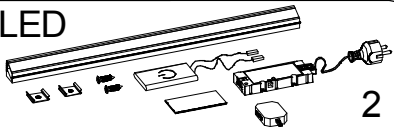

ZAM  2	ZAB  2	ZAC  2	ZAF  2	DB  1	PSF  2
ST 160V 1900N  2	US 800 mm  1	KM  3	PAS  3	K2 8x30  24	K3 8x20  4
VM001 L  1	VM001 R  1	VMN1 L  1	VMN1 R  1	PM-4.180  6	25  1
SM01  2	KS  3	KL4  1	KZ5  1	KL6  1	KP 10 - 13 mm  1
S7 M8x60  10	WSZ  27	S60 M8x60  7	S61 M6x16  20	S67 M6x30  4	N-S50 M8x16  4
MW17 M6  20	S45 M4x25  2	W6 4x16  107	W9 4x30  4	W42 3,9x13  18	LH7.-20  6
KN2 7x50  24	M8  17	M6  4	P8  19	P6  4	NS8  2
GO  6	TK  25	LM3 785mm  36	ZS20  12	NA14  4	NA20  6
OLI L  1	OLI R  1	TM1  48	M12  48	ZP1 30x20  2	ZB9  1
N-NK M8  4	LED  2				

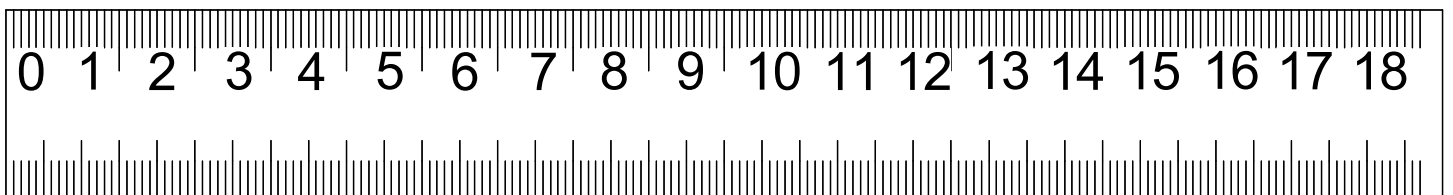

Bed body

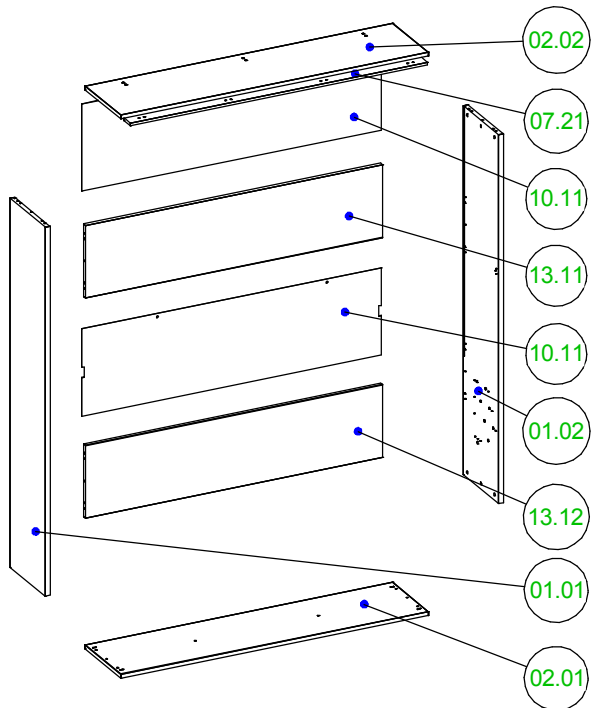

PART	SIZE	QUANTITY
02.01	1819x422x22mm	1
02.02	1819x422x22mm	1
01.01	2138x420x28mm	1
01.02	2138x420x28mm	1
07.21	1759x74x16mm	1
13.12	1759x422x22mm	1
13.11	1759x422x22mm	1
10.11	1773x505x3mm	2

Front bed

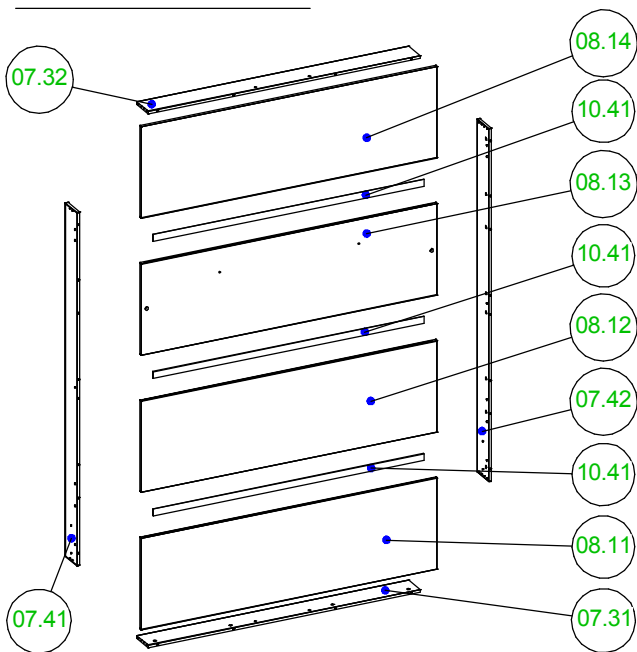

PART	SIZE	QUANTITY
08.11	1751x530x18mm	1
08.12	1751x530x18mm	1
08.13	1751x530x18mm	1
08.14	1751x530x18mm	1
07.41	2046x140x16mm	1
07.42	2046x140x16mm	1
07.31	1608x138x16mm	1
07.32	1608x138x16mm	1
10.41	1603x39x3mm	3

Bed frame

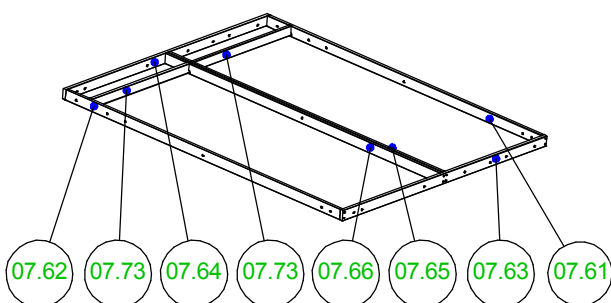

PART	SIZE	QUANTITY
07.73	770,5x55x20mm	2
07.61	1967x60x20mm	1
07.62	1967x60x20mm	1
07.65	1967x60x20mm	1
07.66	1967x60x20mm	1
07.63	1607x60x20mm	1
07.64	1607x60x20mm	1

▶ 1

EN You will need the following hardware to complete this step:
PL Niezbędne do montażu :

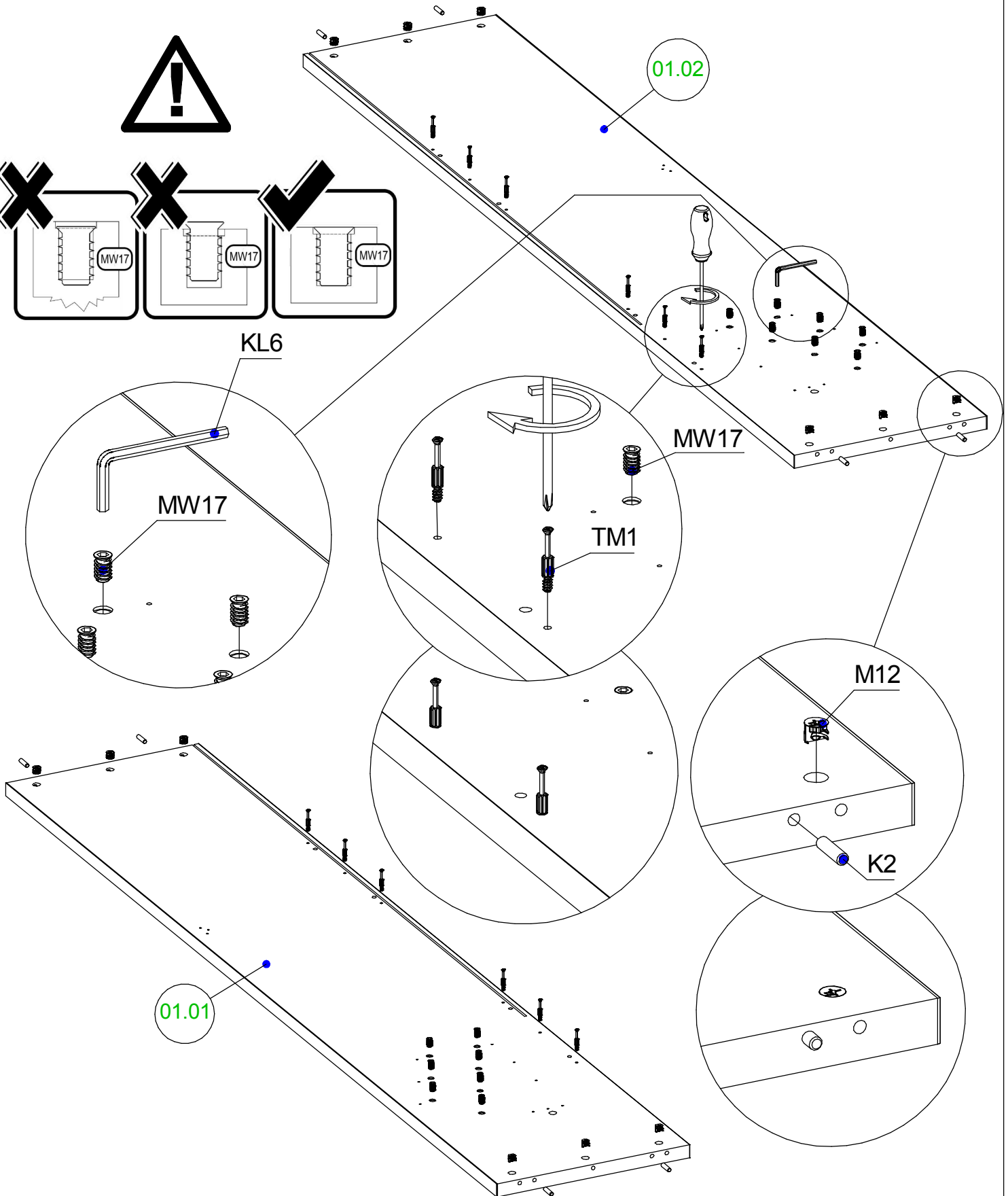
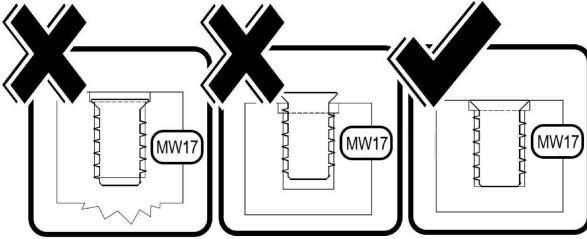
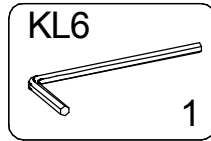
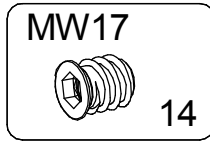
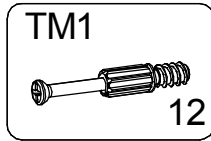
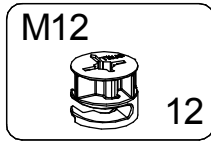
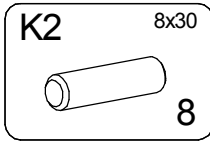
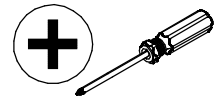

► **2** EN You will need the following hardware to complete this step:
 PL Niezbędne do montażu :

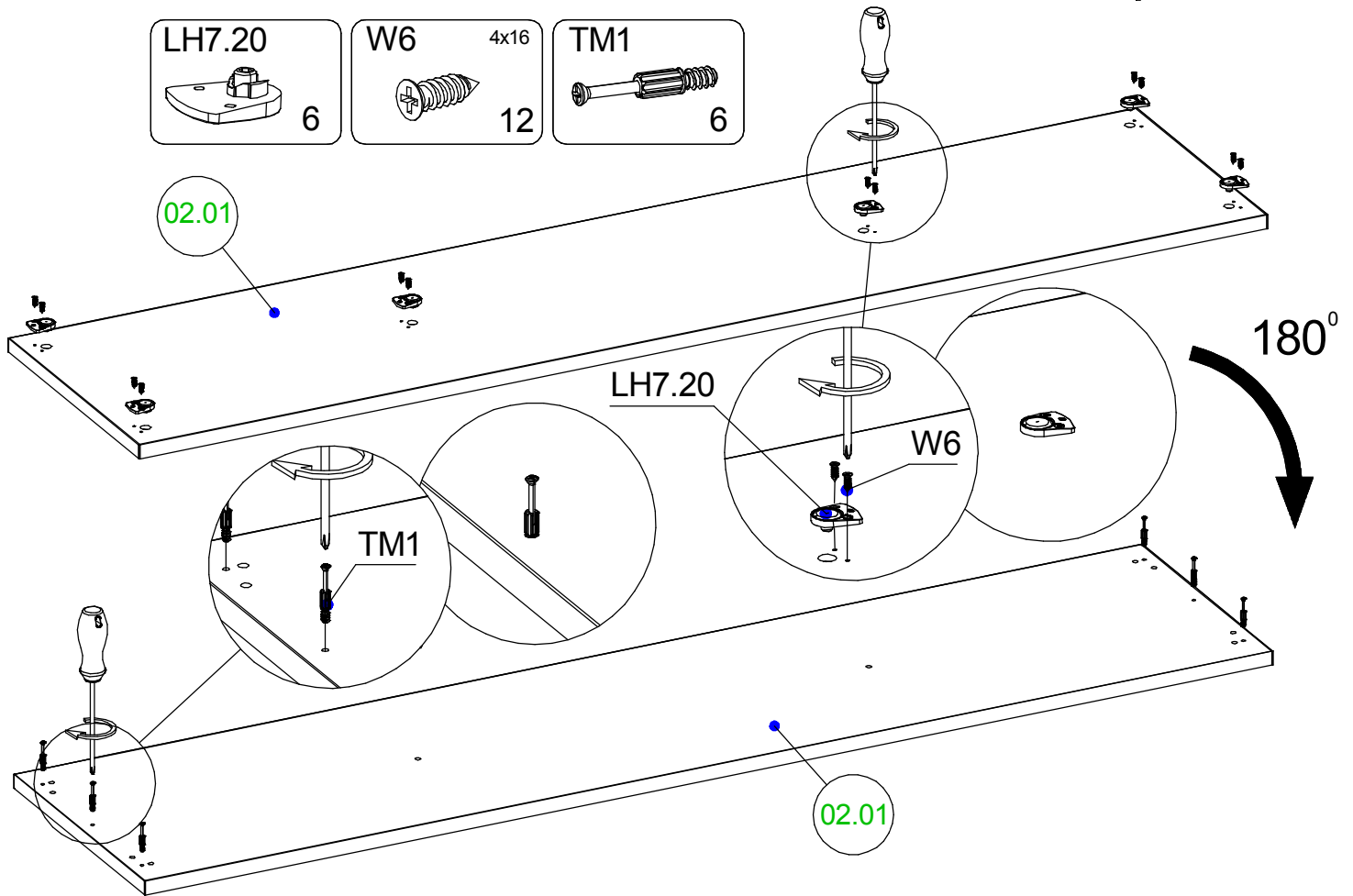
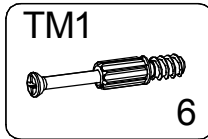
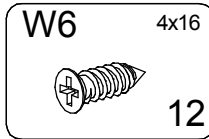
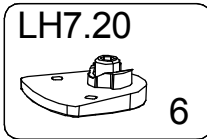
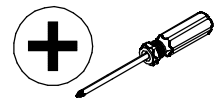

► **3** EN You will need the following hardware to complete this step:
 PL Niezbędne do montażu :

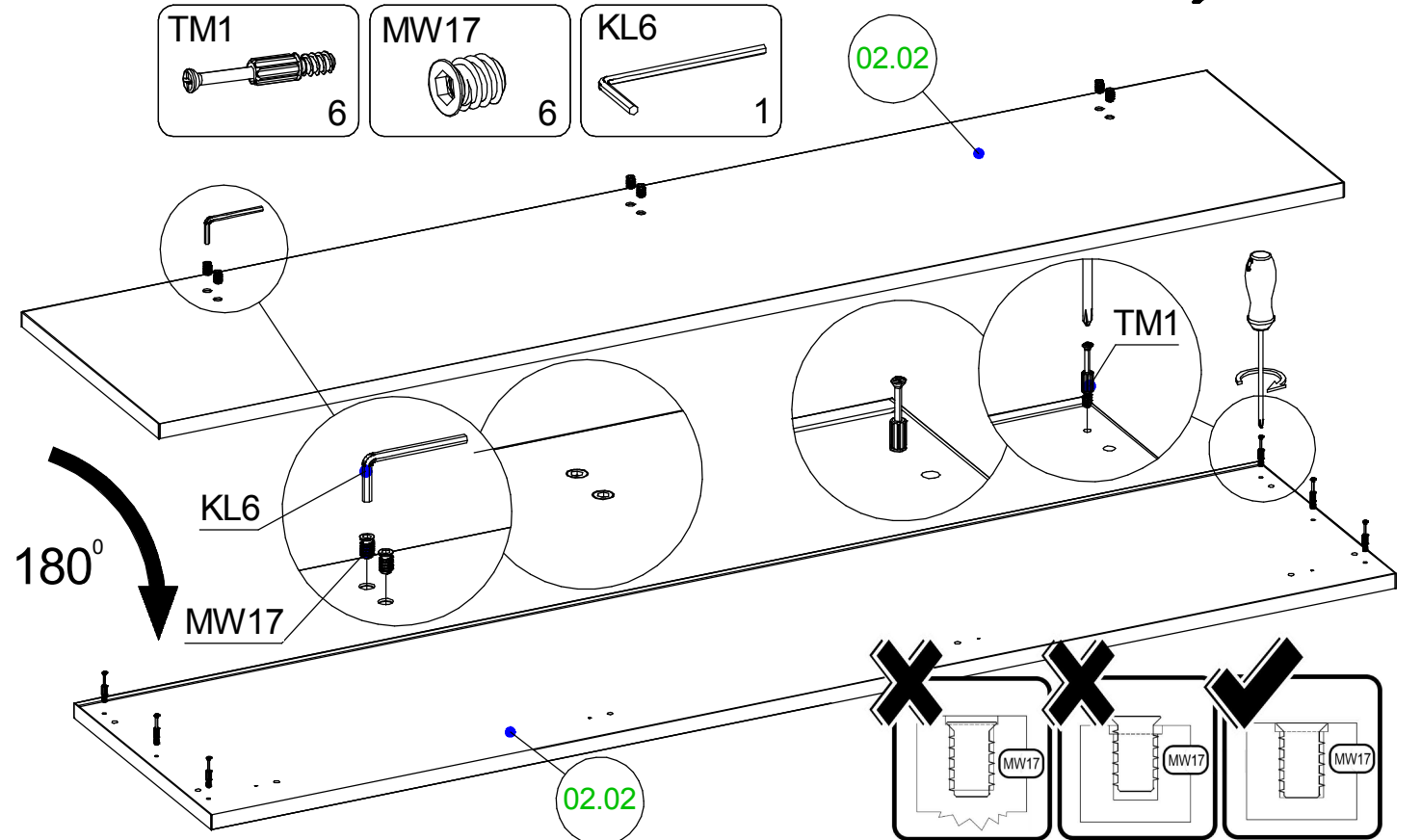
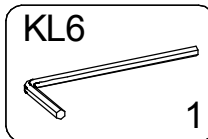
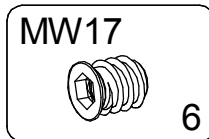
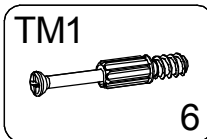
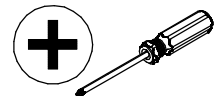

► 4

EN You will need the following hardware to complete this step:
PL Niezbędne do montażu :

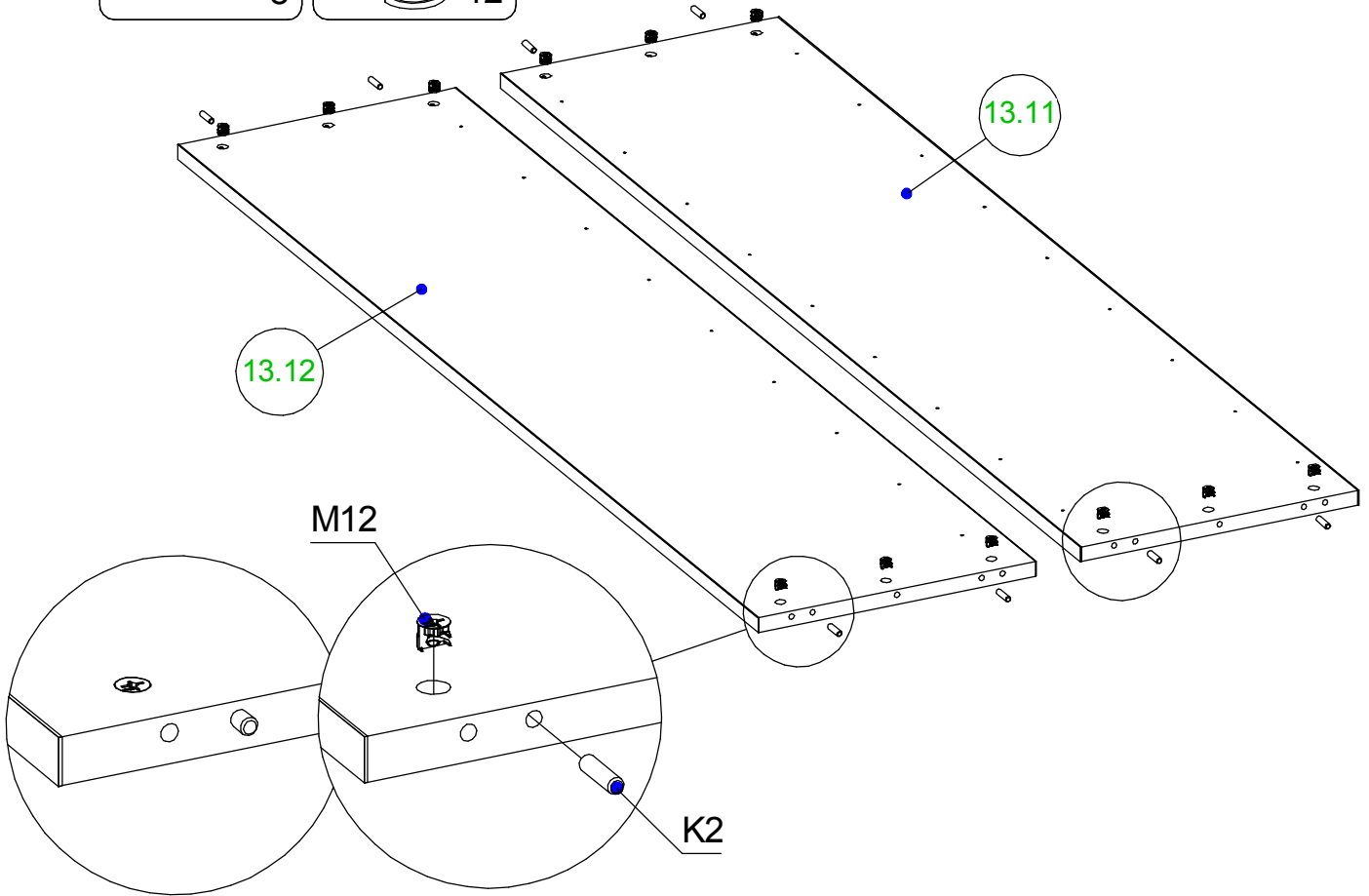
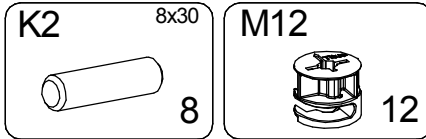
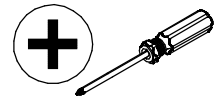

► 5

EN You will need the following hardware to complete this step:
PL Niezbędne do montażu :

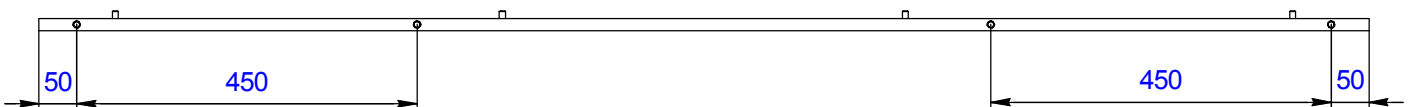
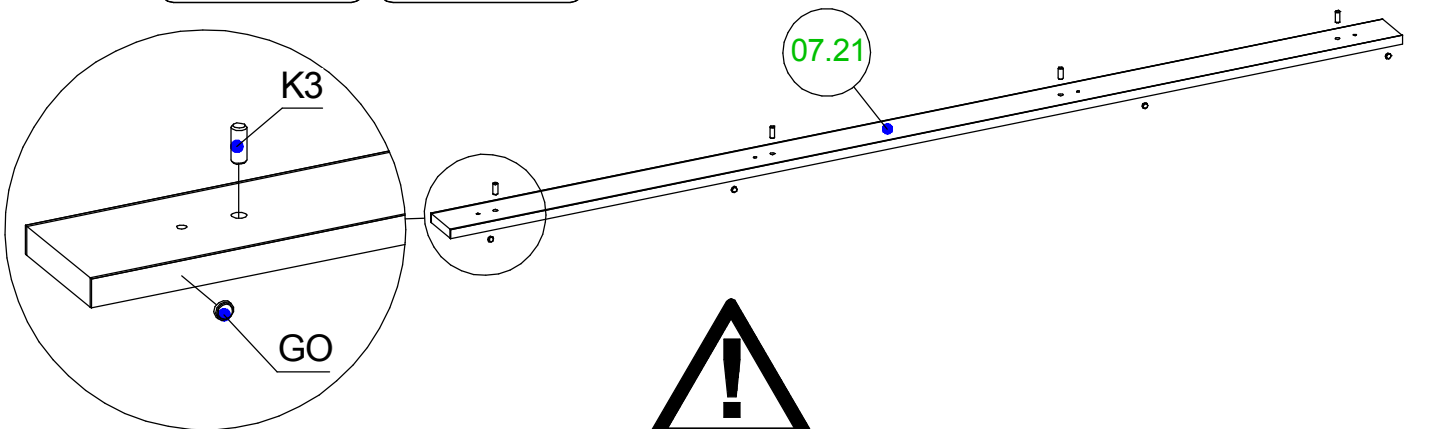
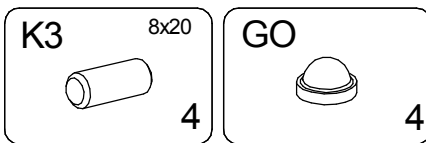

▶ 6

EN You will need the following hardware to complete this step:
PL Niezbędne do montażu :

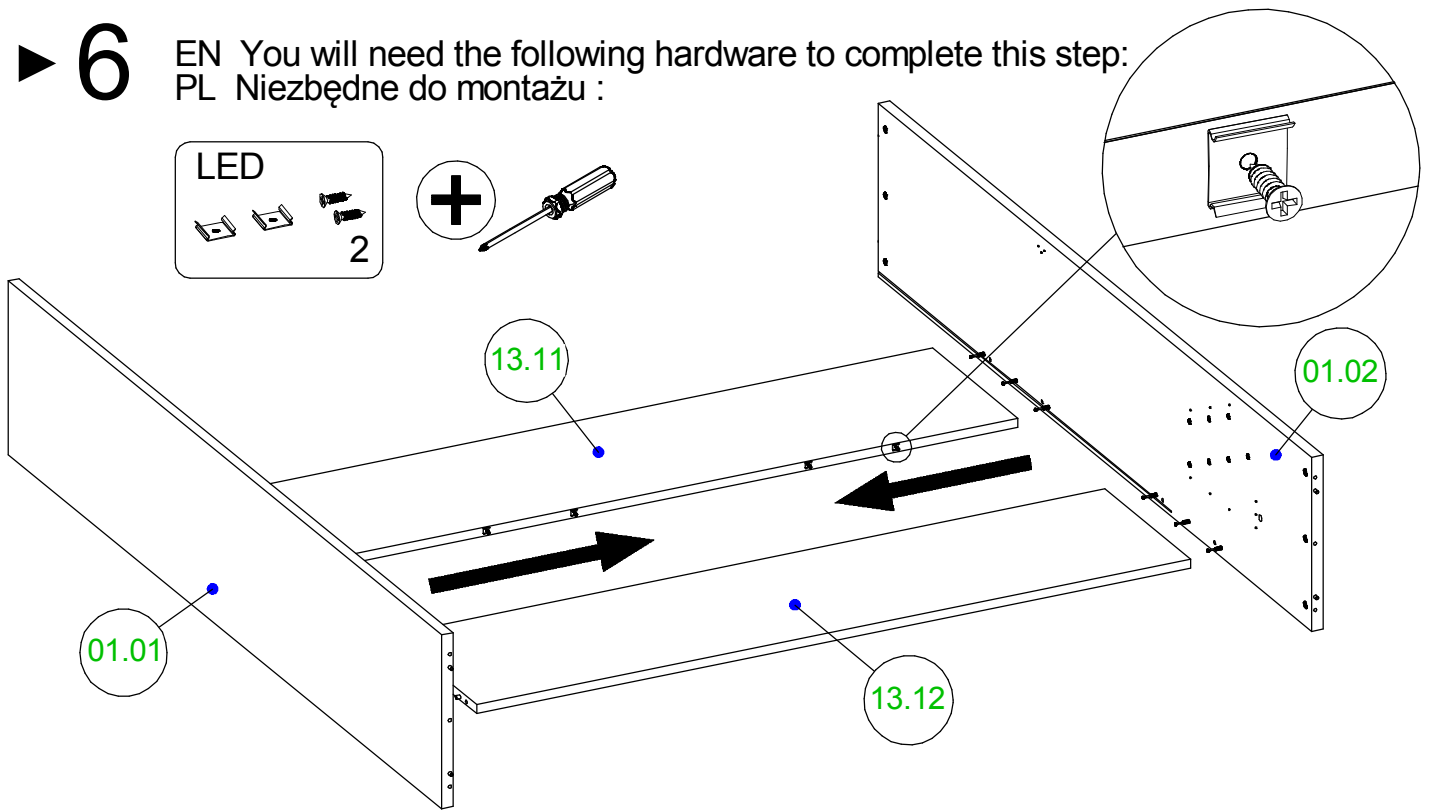
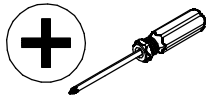
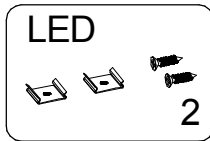

▶ 7

EN You will need the following hardware to complete this step:
PL Niezbędne do montażu :

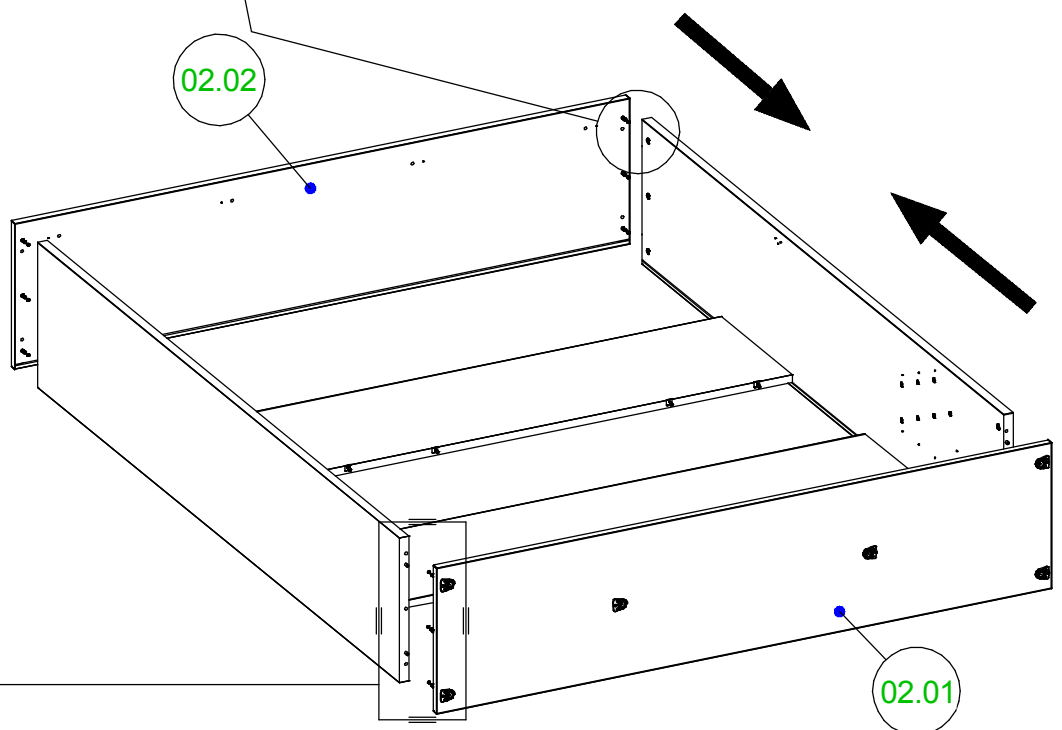
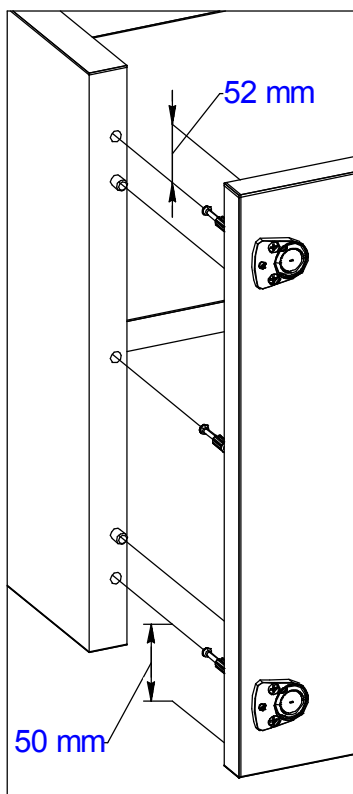
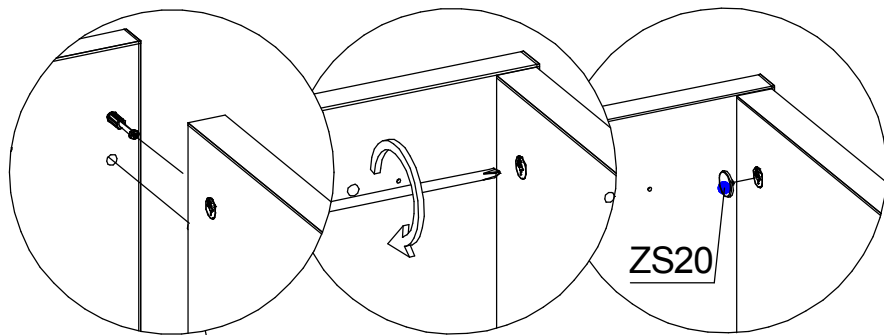
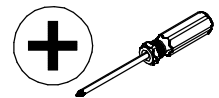
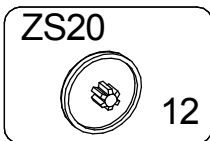

▶ 8

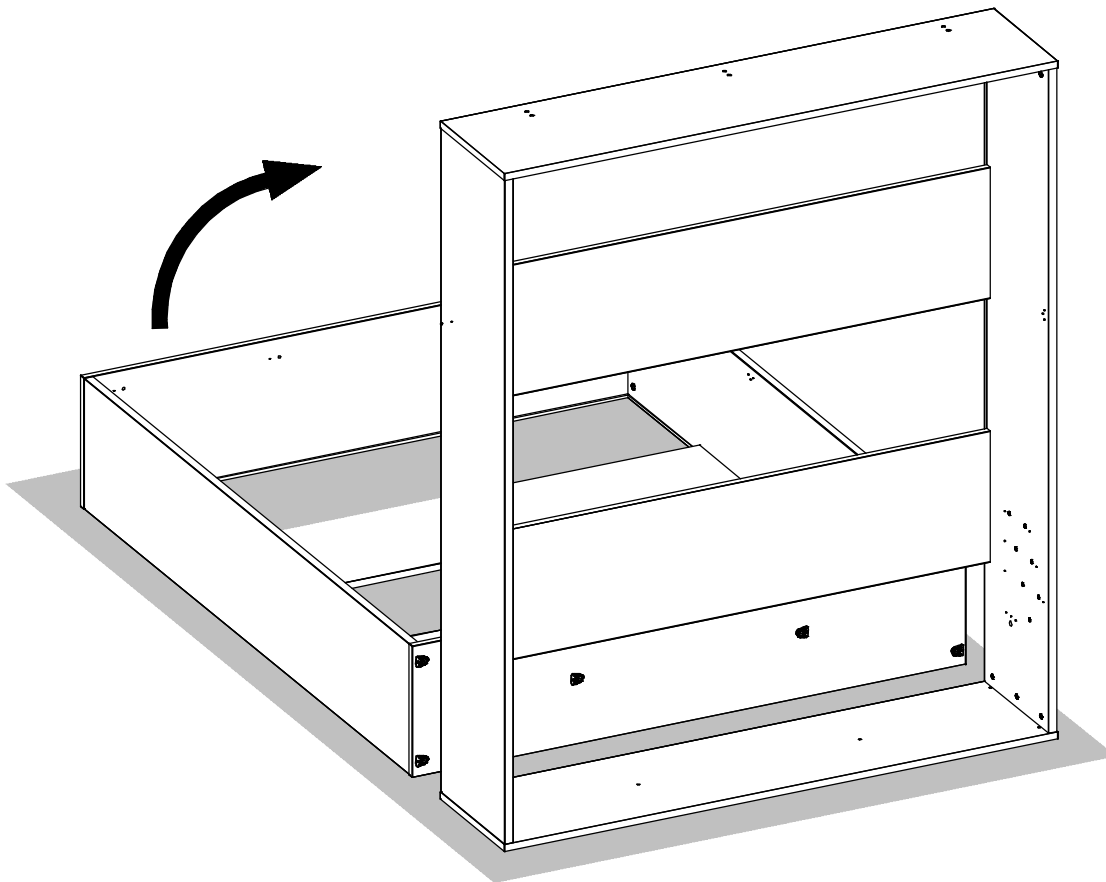

▶ 9

EN You will need the following hardware to complete this step:
PL Niezbędne do montażu :

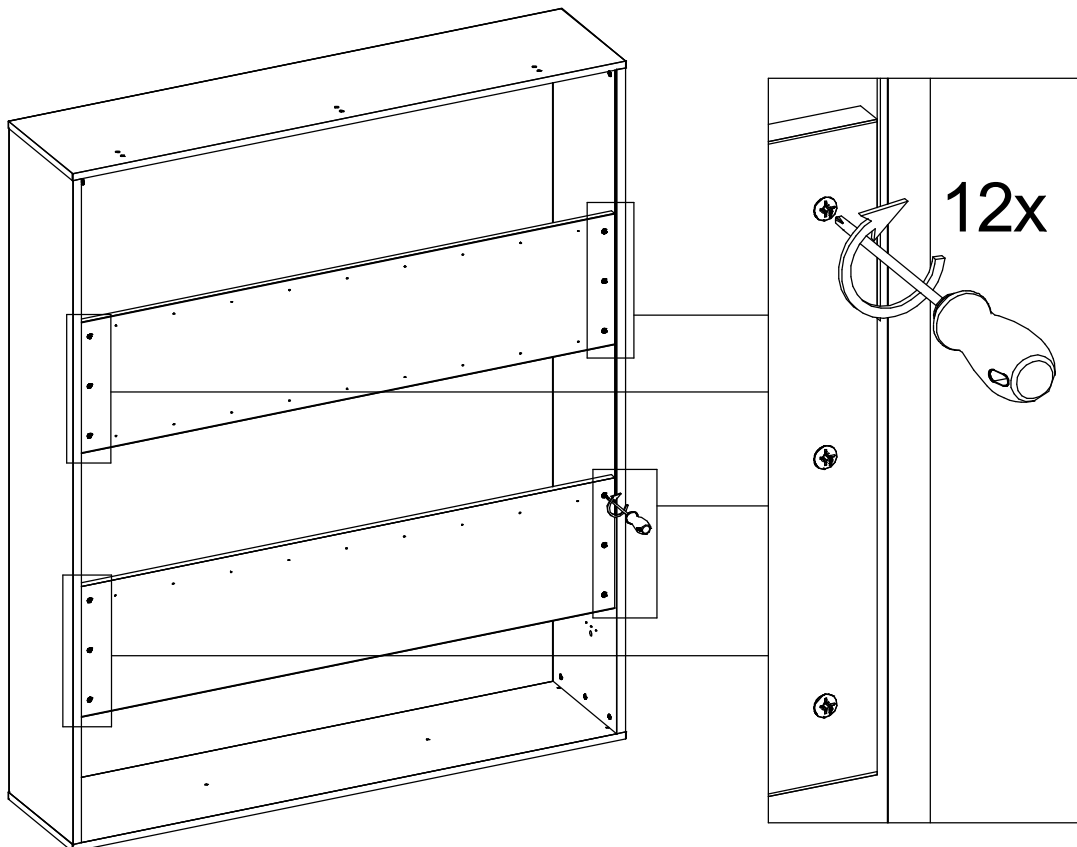
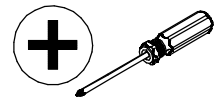

► **10** EN You will need the following hardware to complete this step:
 PL Niezbędne do montażu :

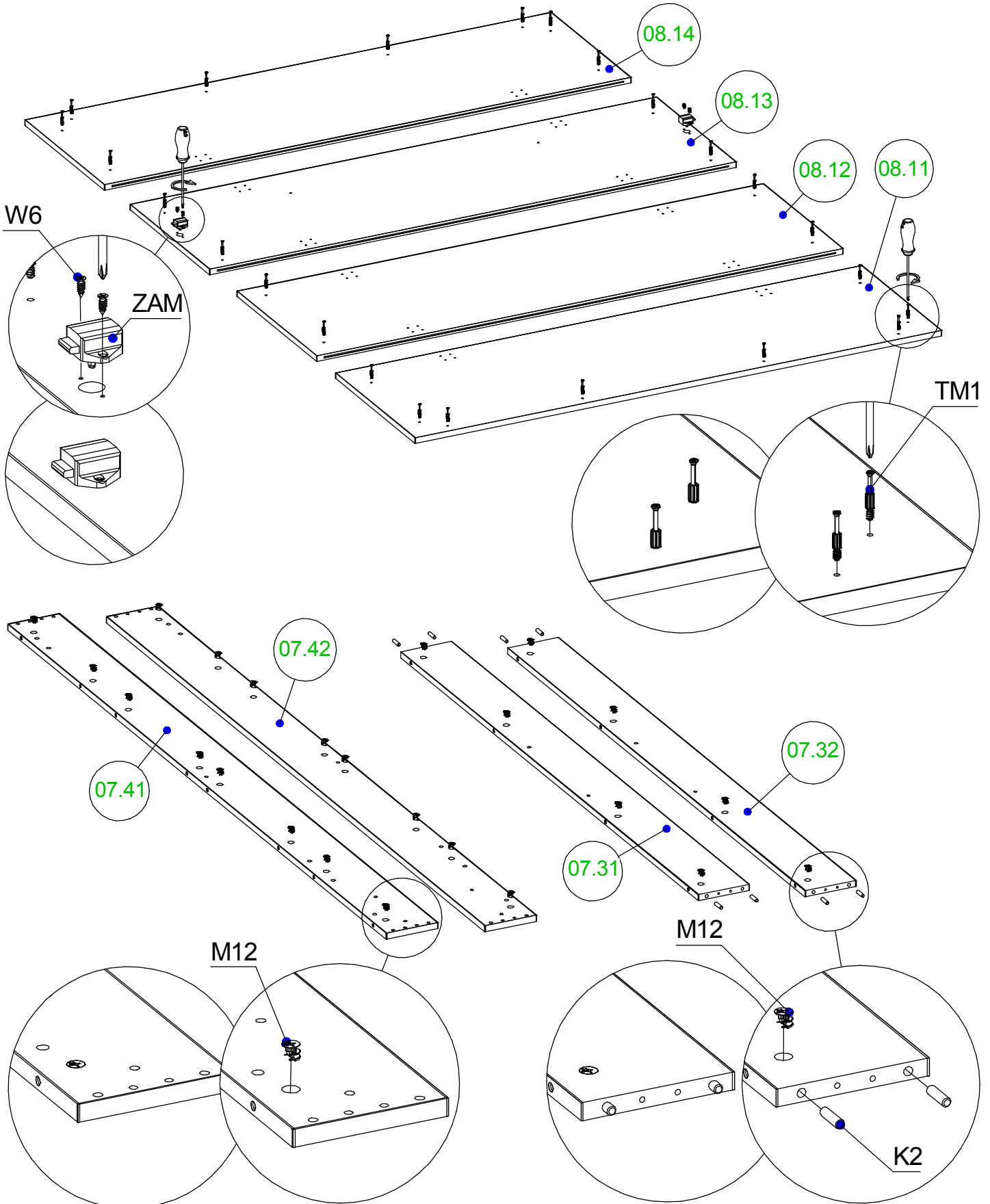
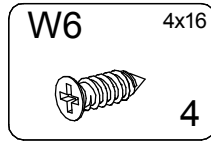
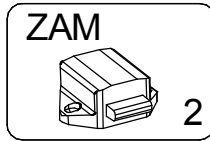
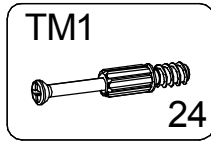
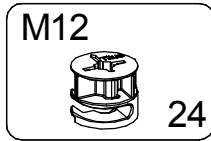
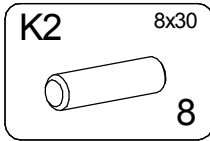
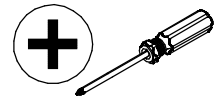

►11

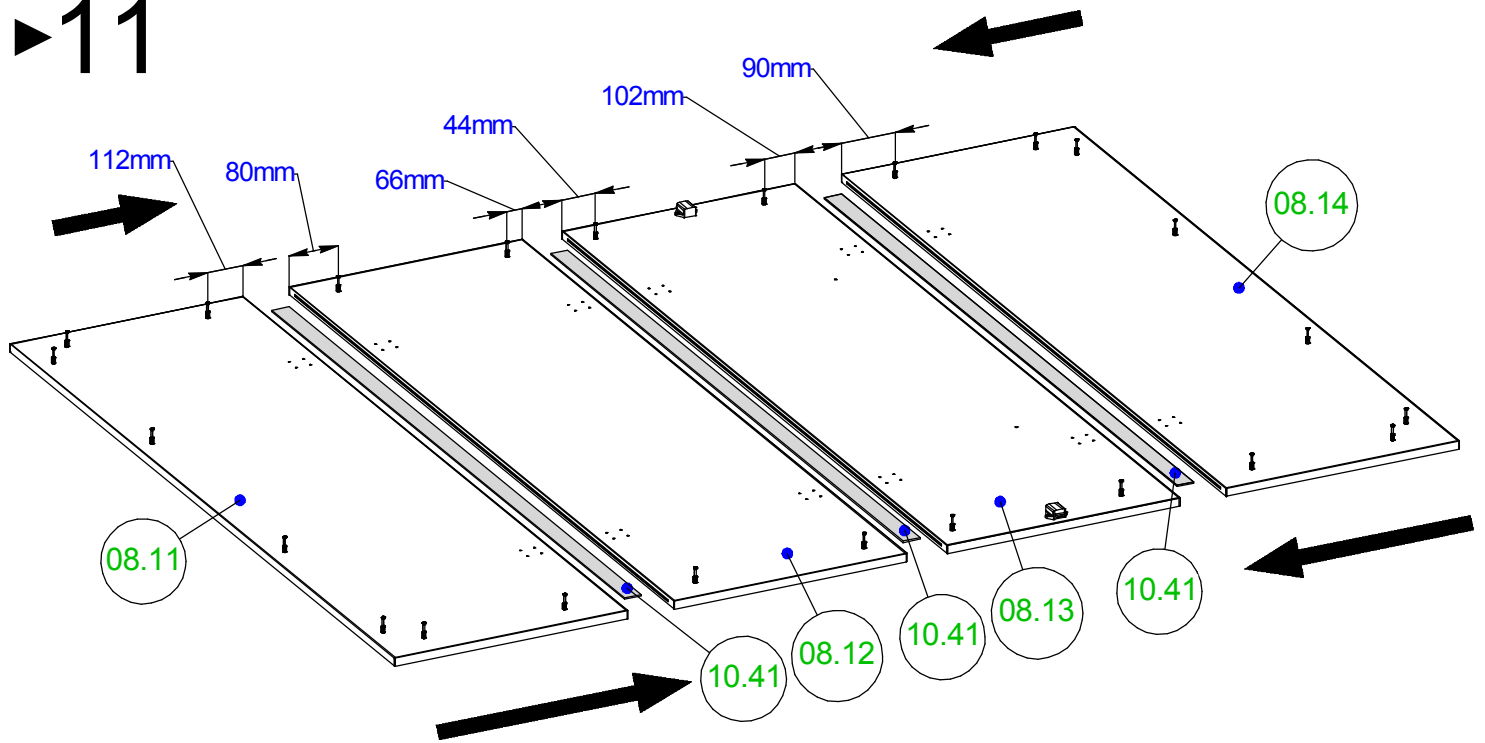

►12

EN You will need the following hardware to complete this step:
 PL Niezbędne do montażu :

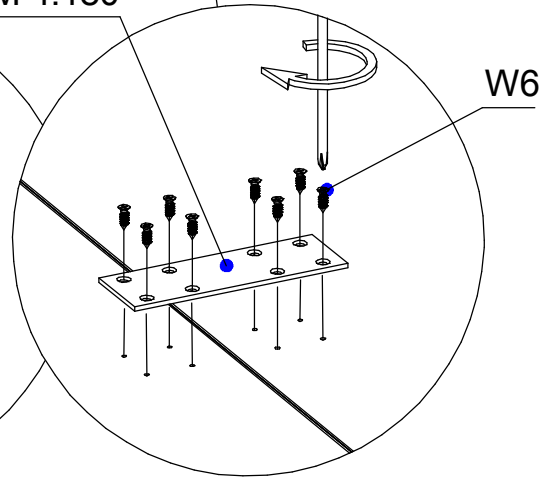
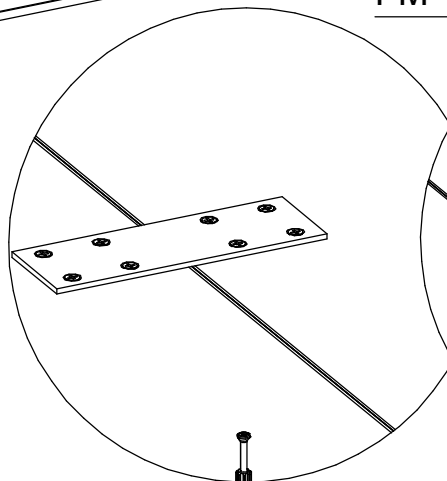
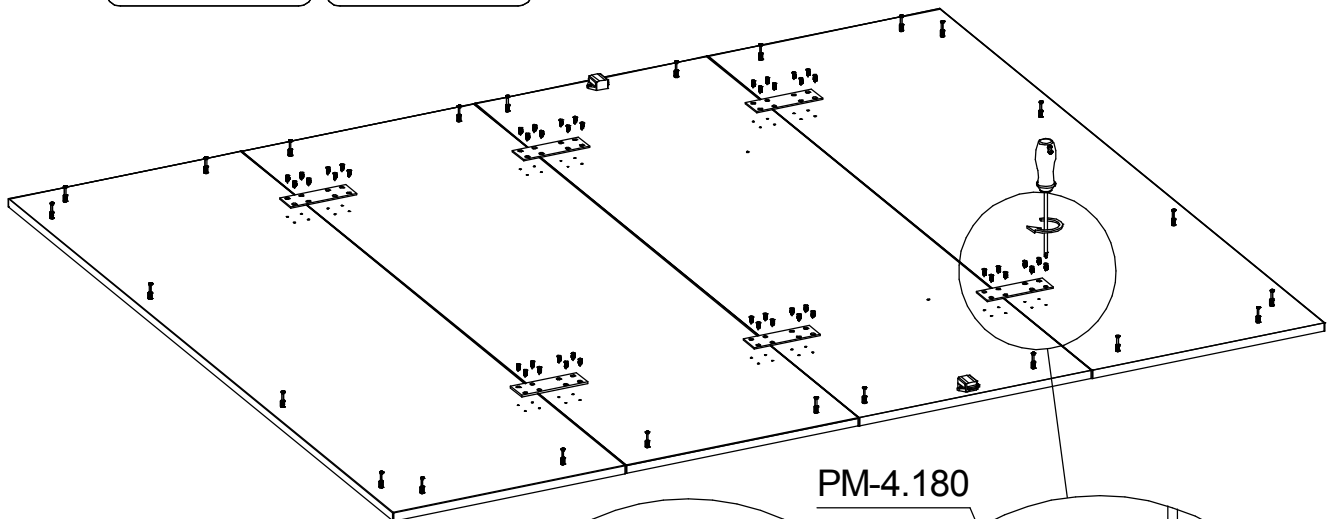
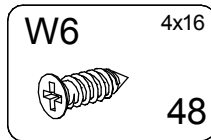
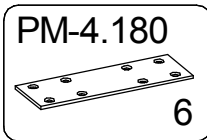
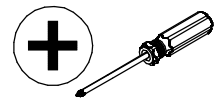

► **13** EN You will need the following hardware to complete this step:
 PL Niezbędne do montażu :

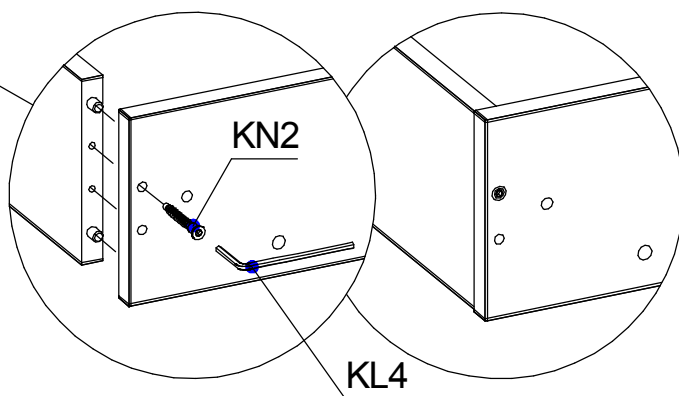
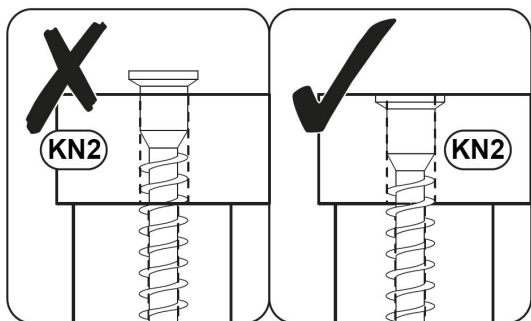
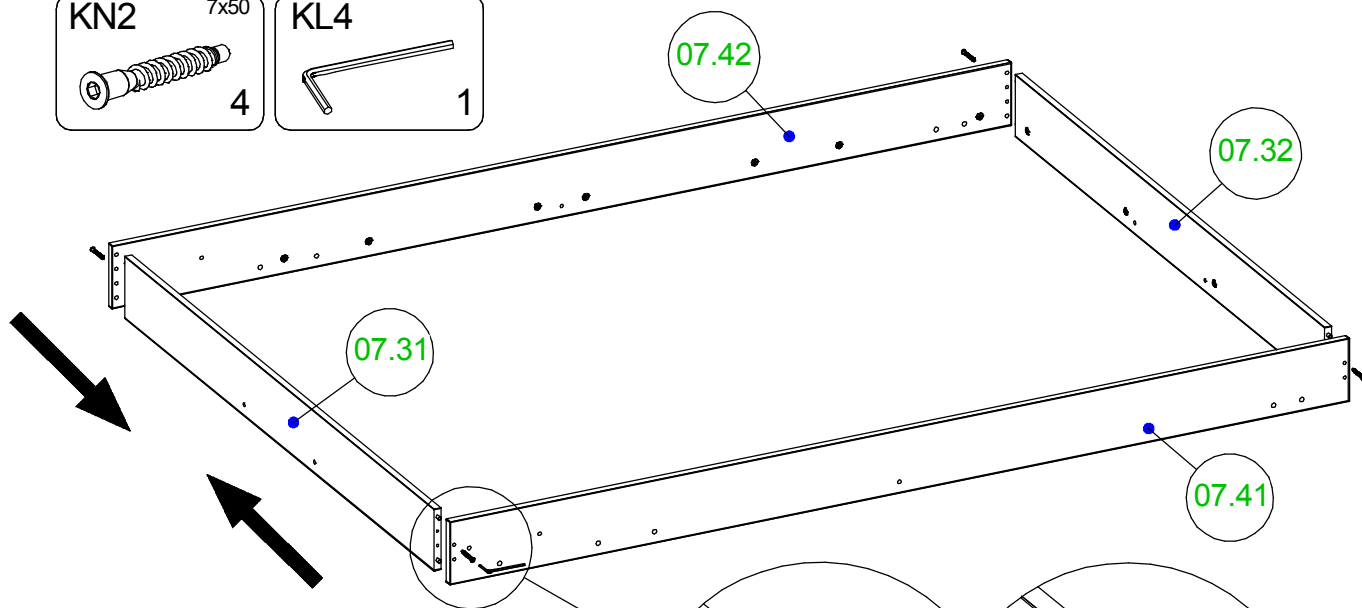
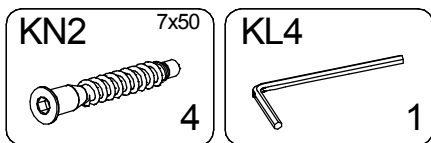

► **14** EN You will need the following hardware to complete this step:
 PL Niezbędne do montażu :

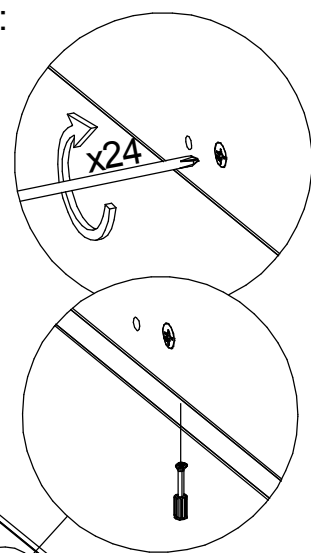
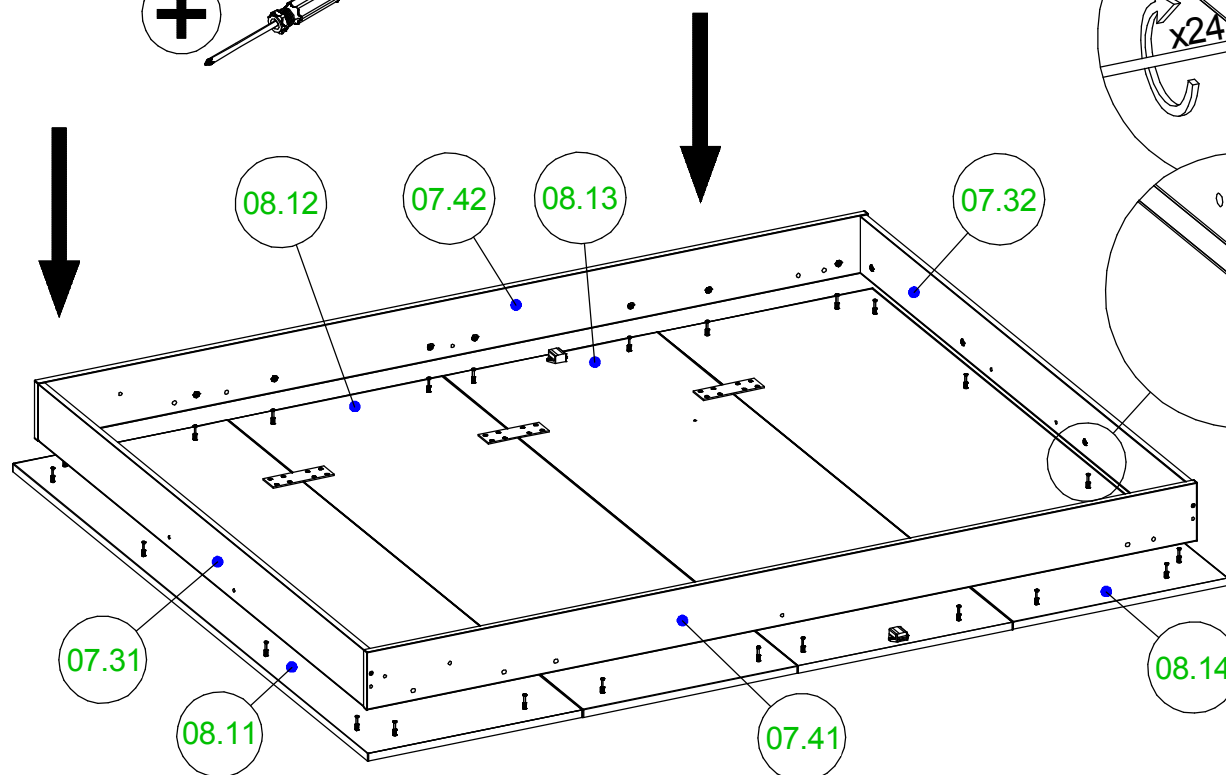
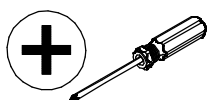

► **15** EN You will need the following hardware to complete this step:
 PL Niezbędne do montażu :

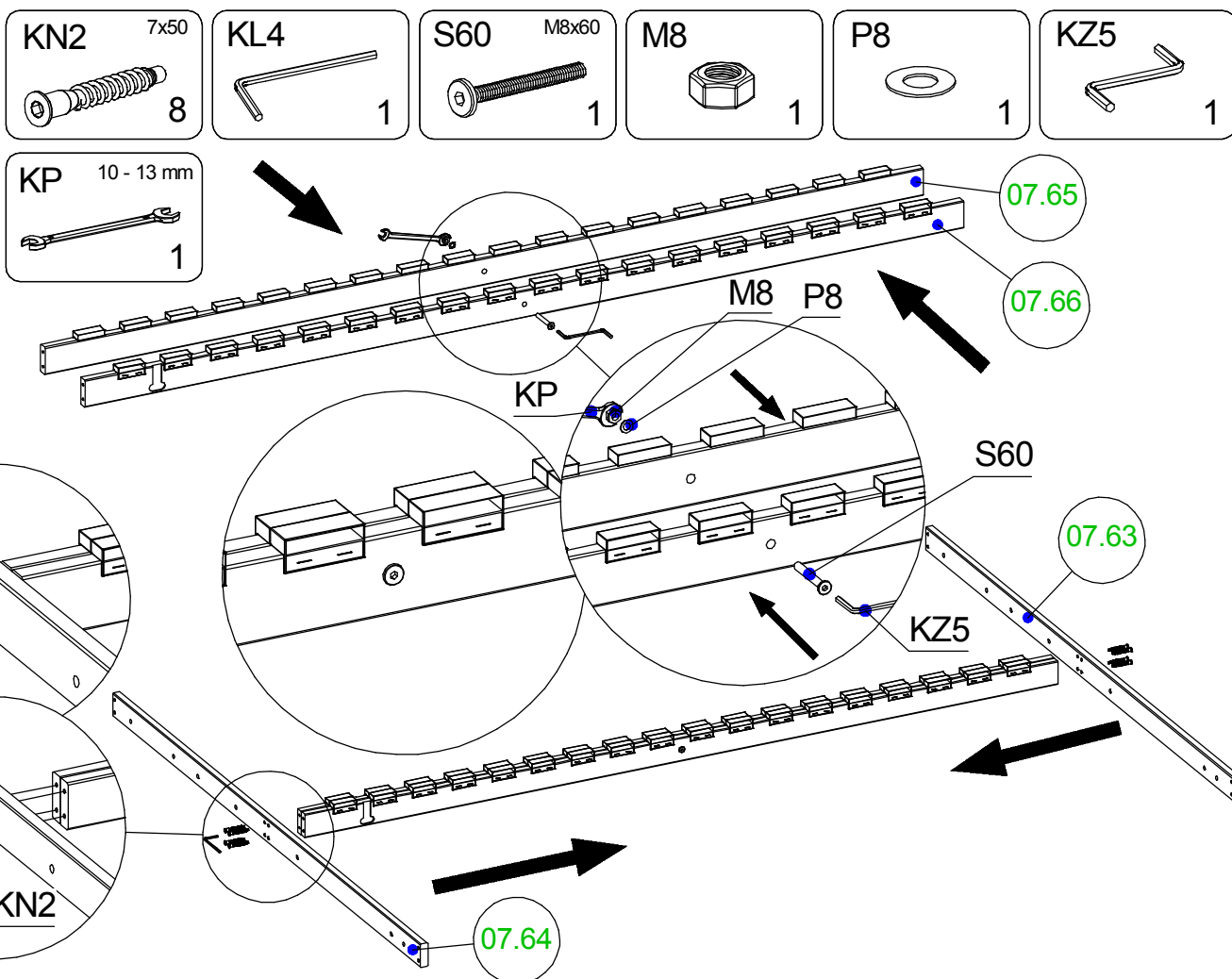

► **16** EN You will need the following hardware to complete this step:
 PL Niezbędne do montażu :

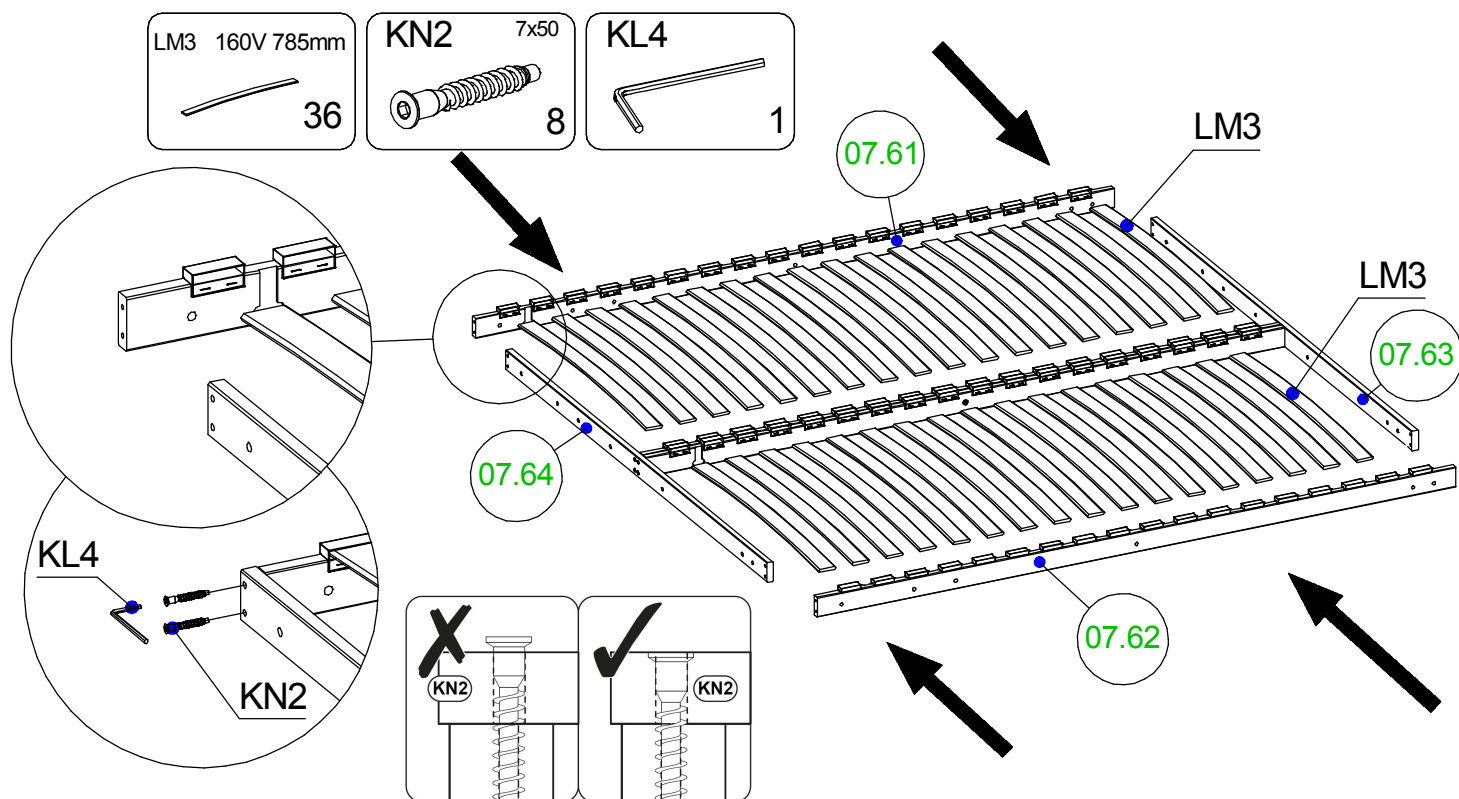

►17

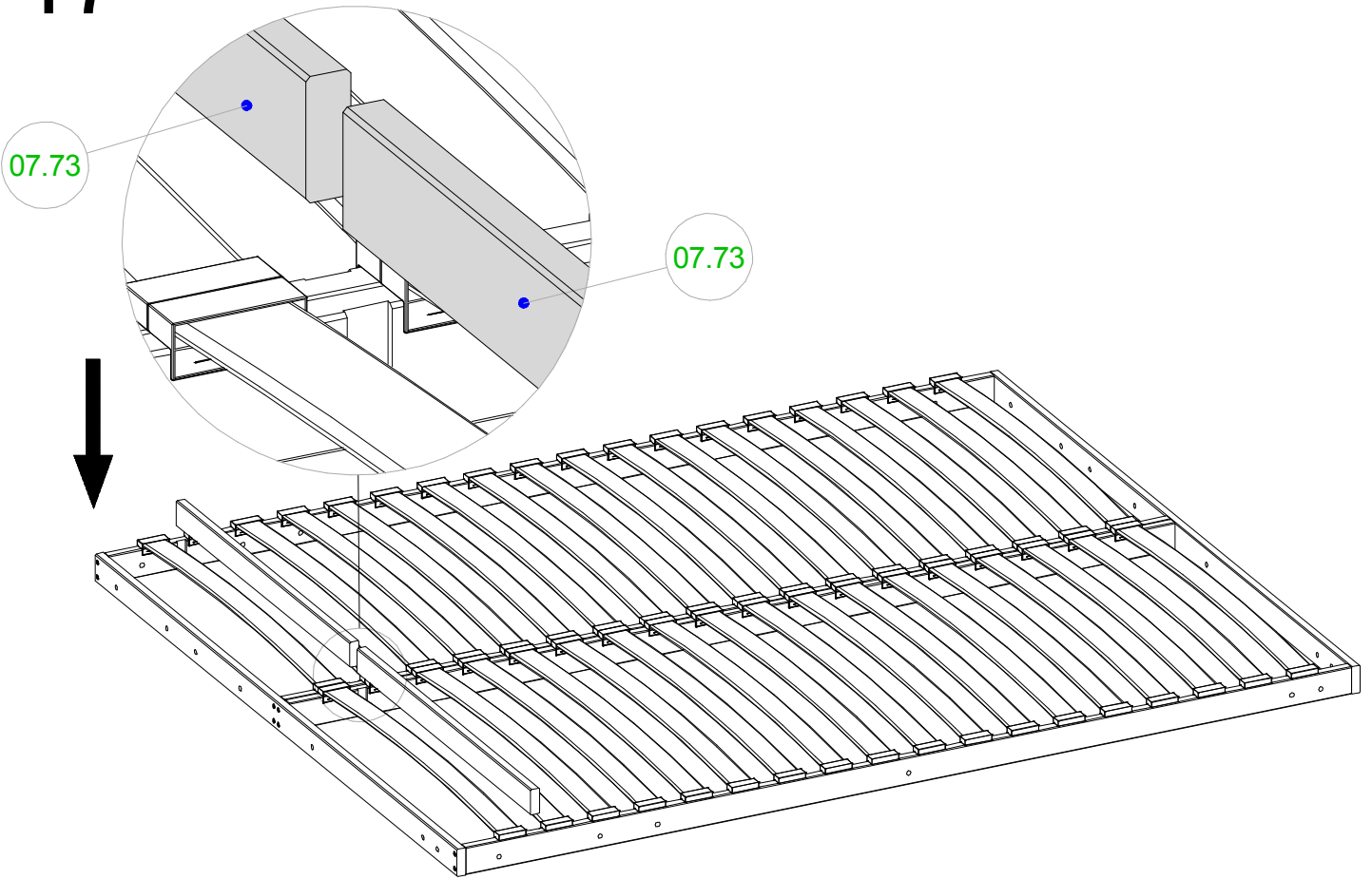

►18

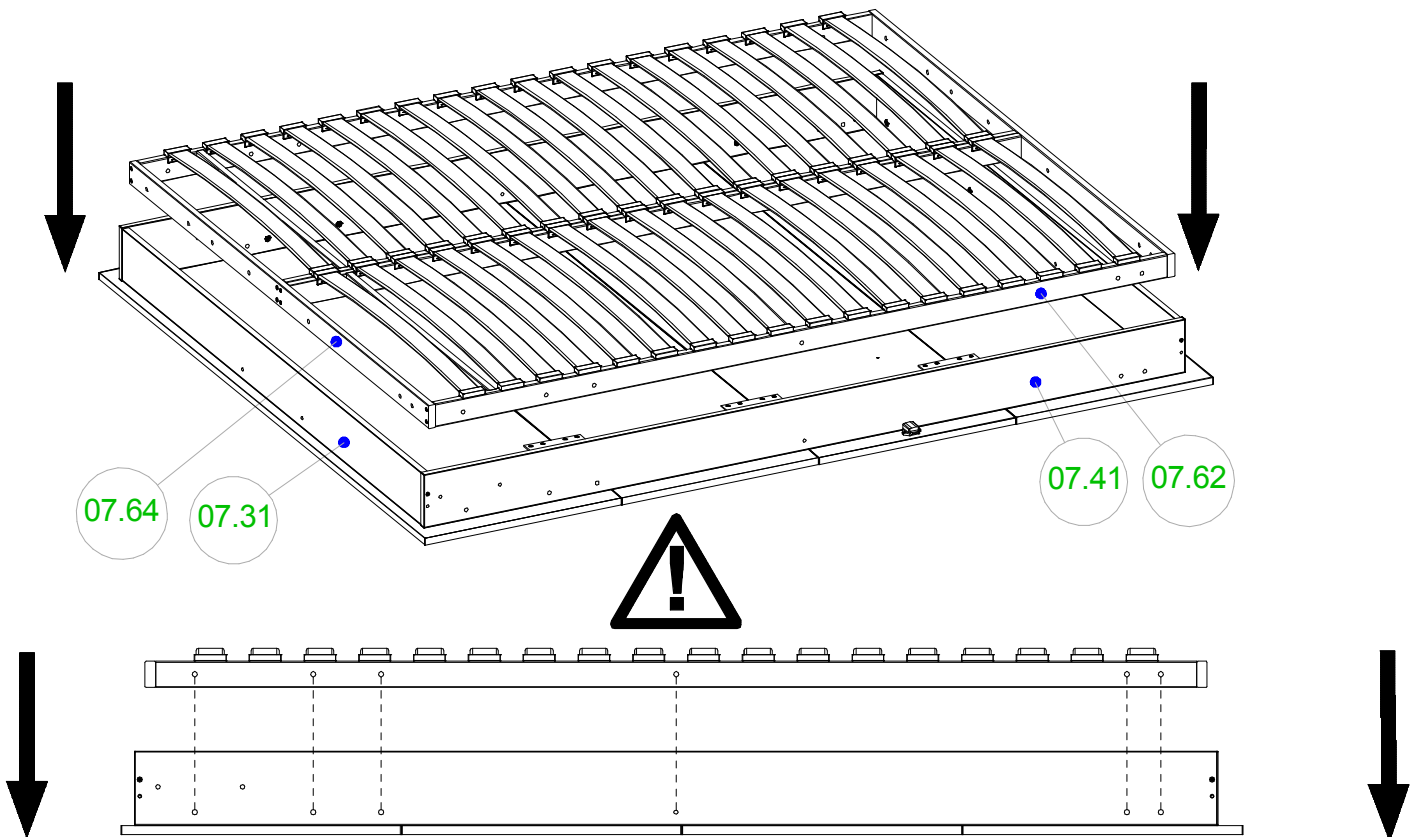

► **19** EN You will need the following hardware to complete this step:
 PL Niezbędne do montażu :

S60 M8x60 6	S67 M6x30 4	M8 6	M6 4	P8 6	P6 4
KN2 7x50 2	KL4 1	VM001 L 1	VM001 R 1	KZ5 1	KP 10 - 13 mm 1

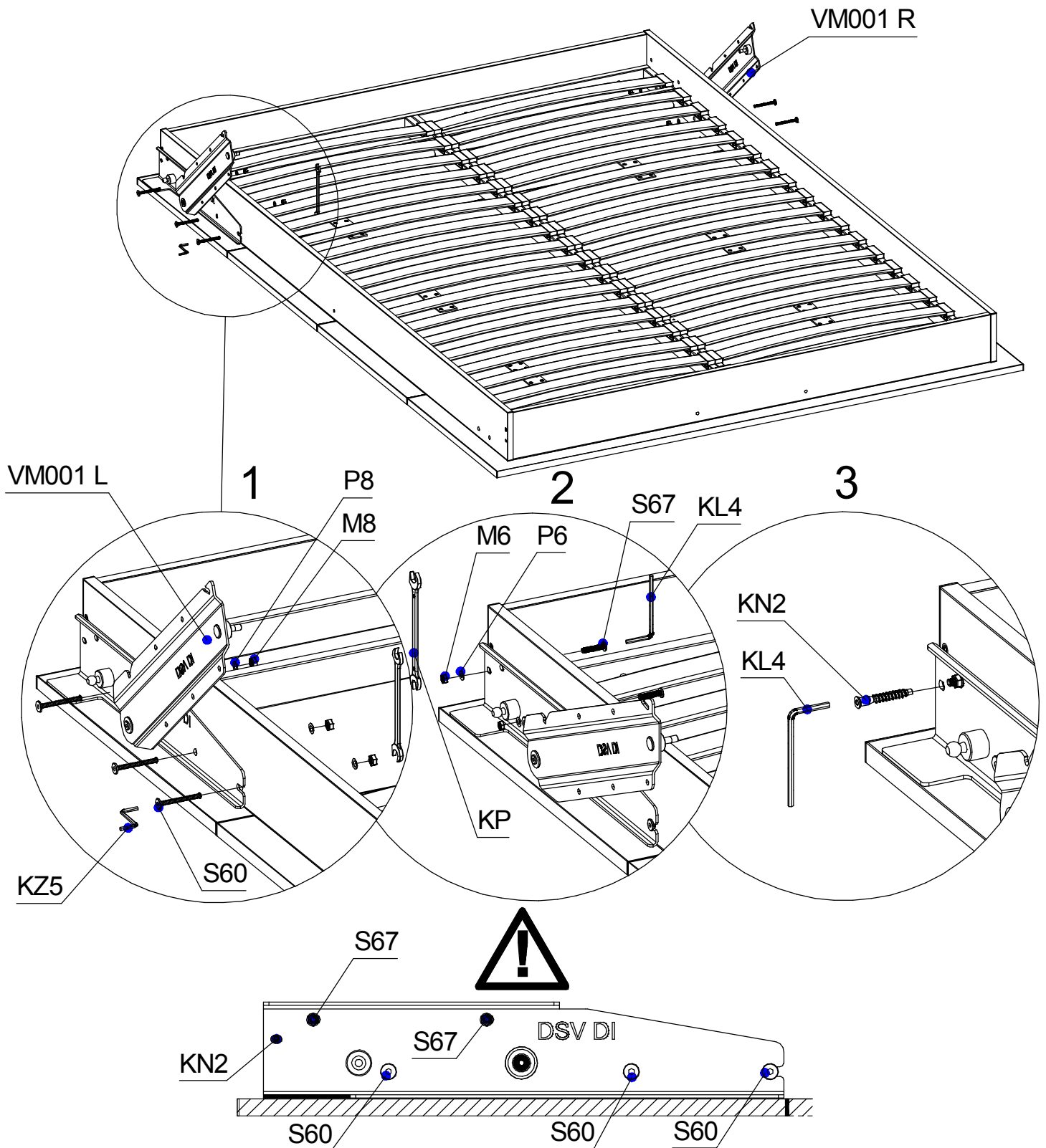

► **20** EN You will need the following hardware to complete this step:
 PL Niezbędne do montażu :

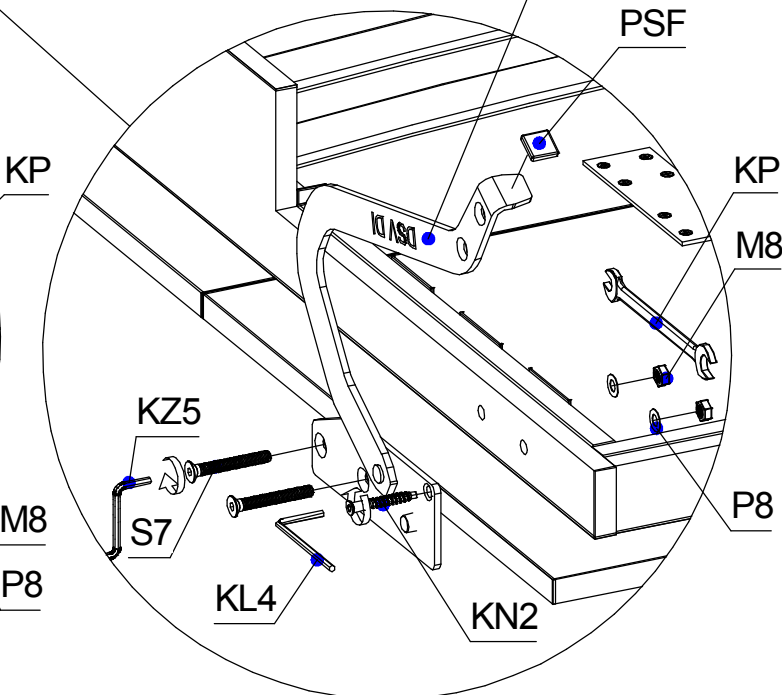
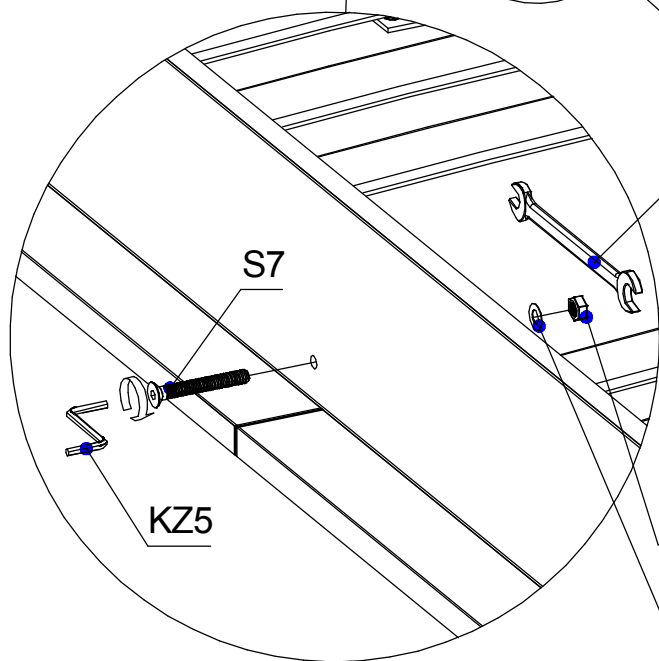
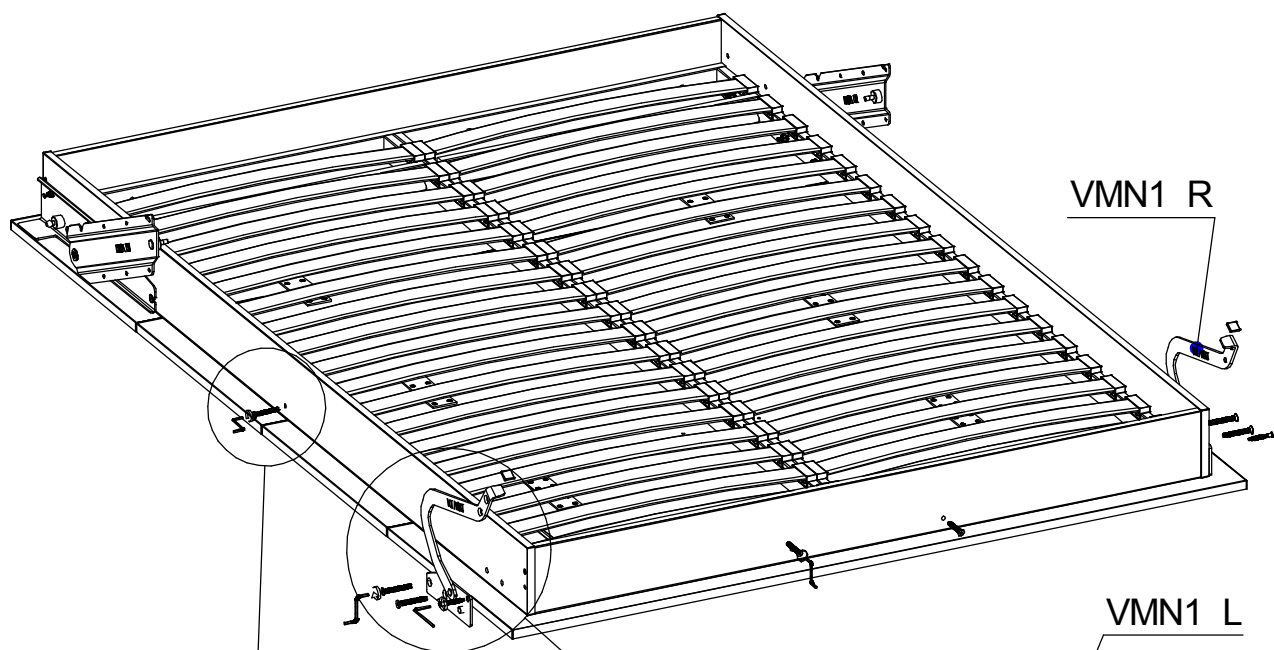
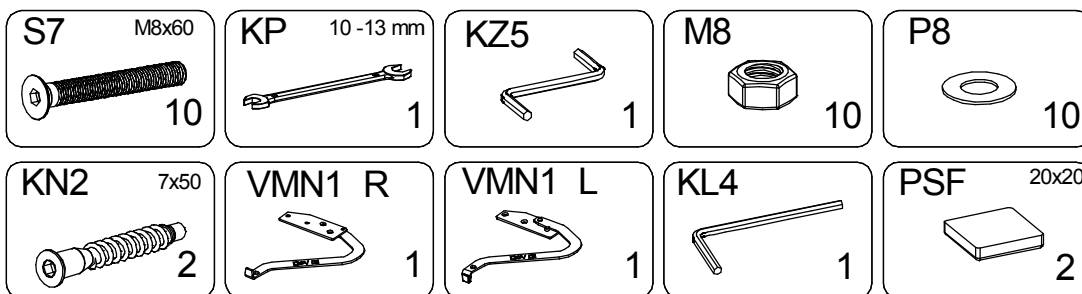

►21 EN You will need the following hardware to complete this step:
 PL Niezbędne do montażu :

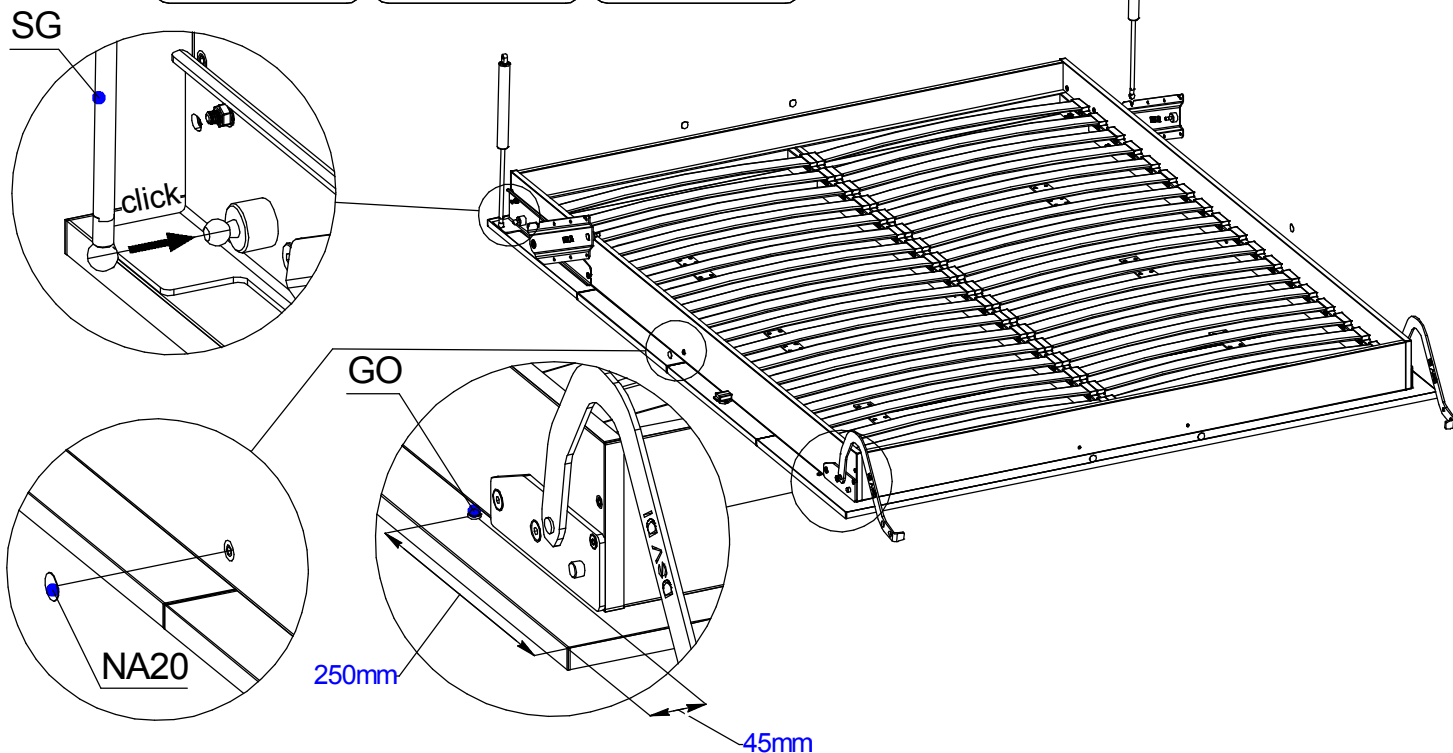
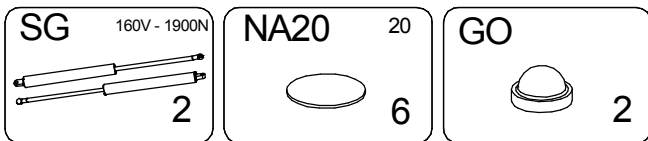

►22 EN You will need the following hardware to complete this step:
 PL Niezbędne do montażu :

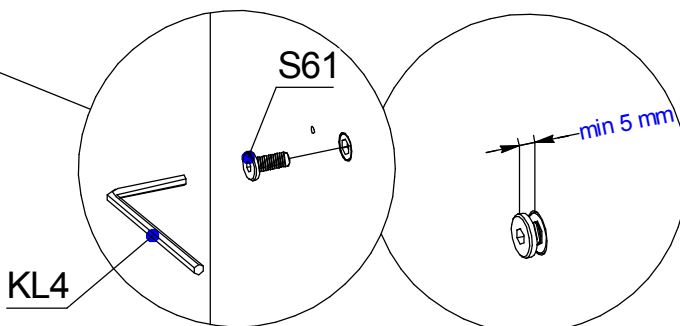
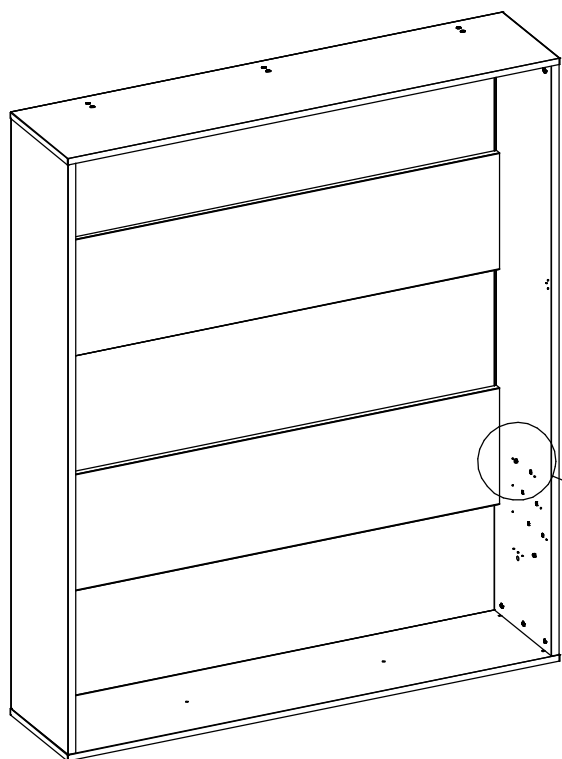
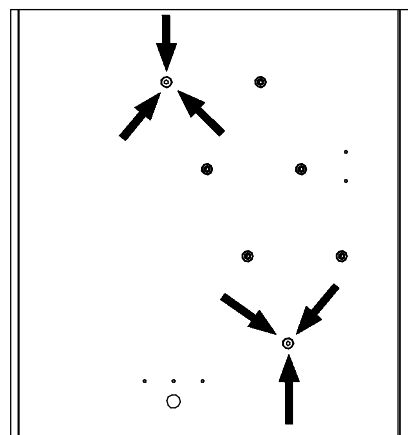
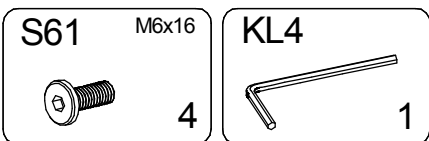

► **23** EN You will need the following hardware to complete this step:
 PL Niezbędne do montażu :

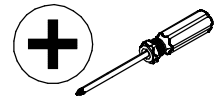

S61 M6x16 10	KL4 1
US 800mm 1	S45 M4x25 2

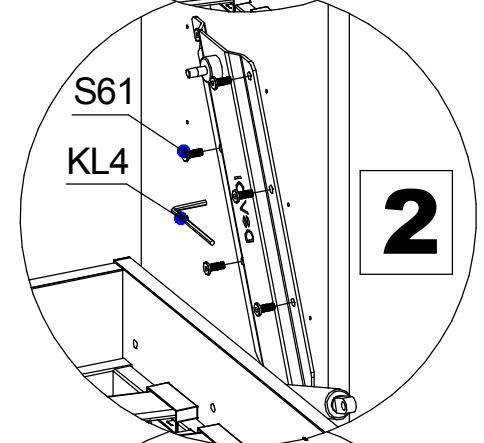
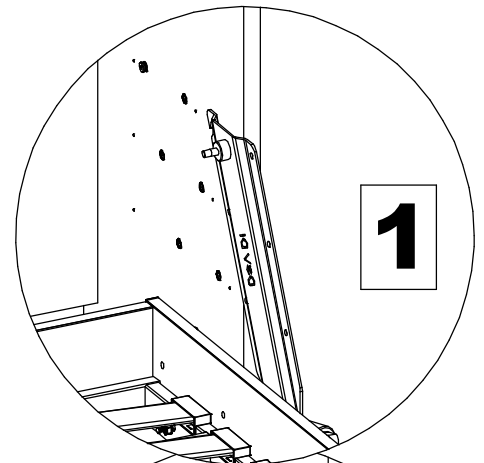
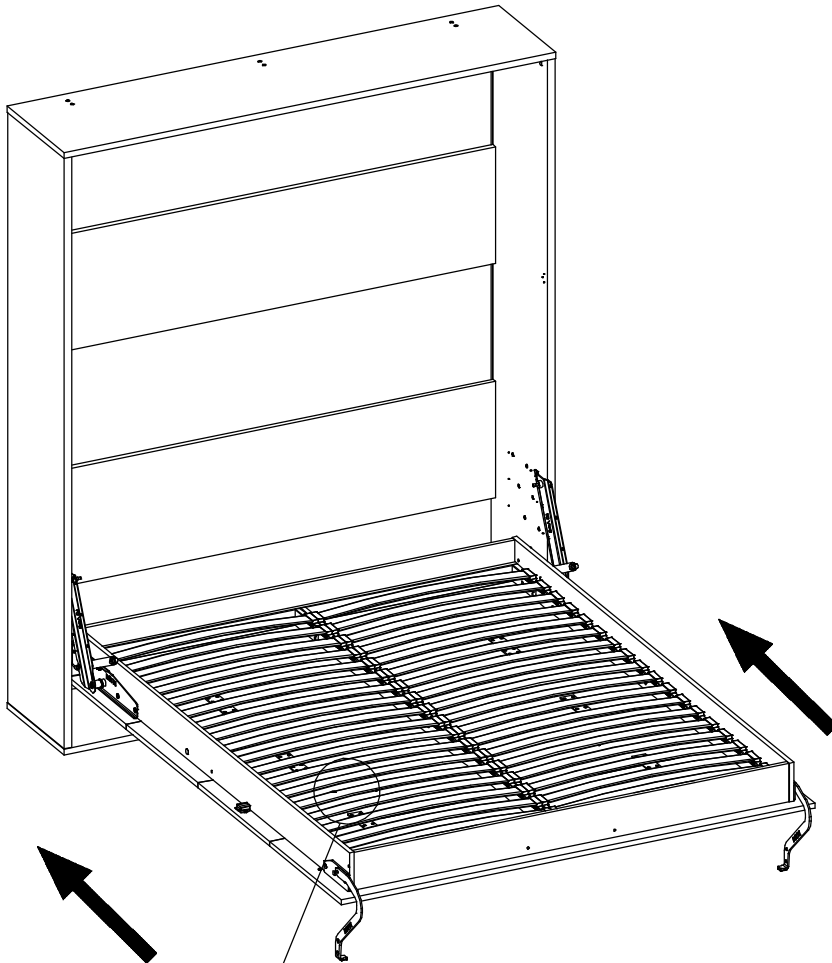
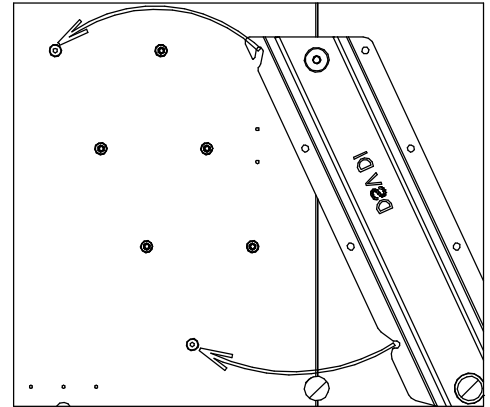

2

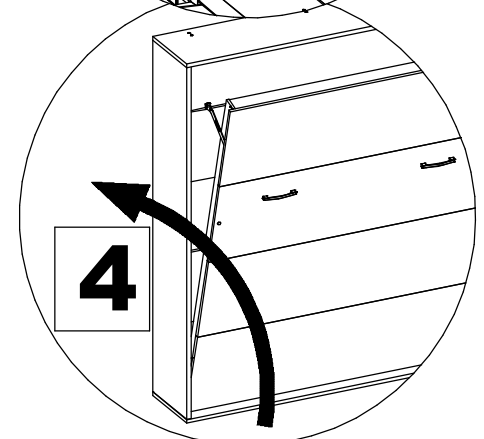
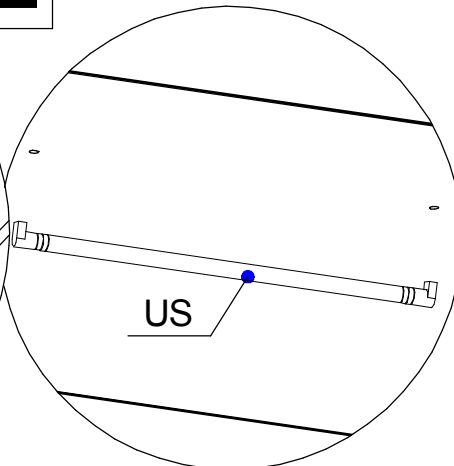
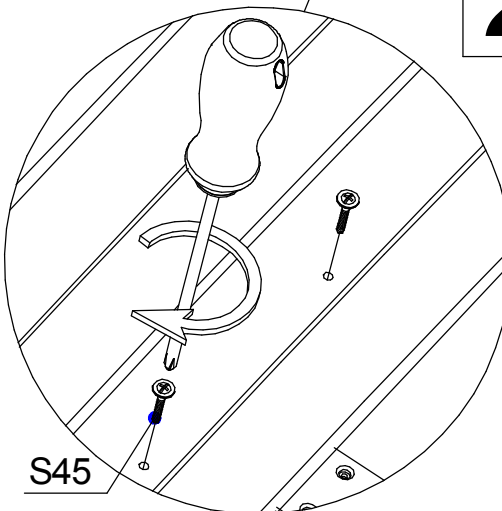

► **24** EN You will need the following hardware to complete this step:
 PL Niezbędne do montażu :

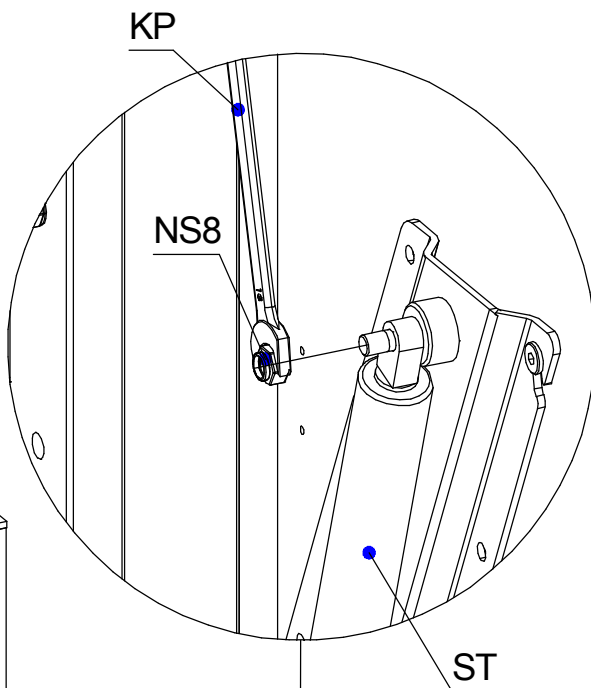
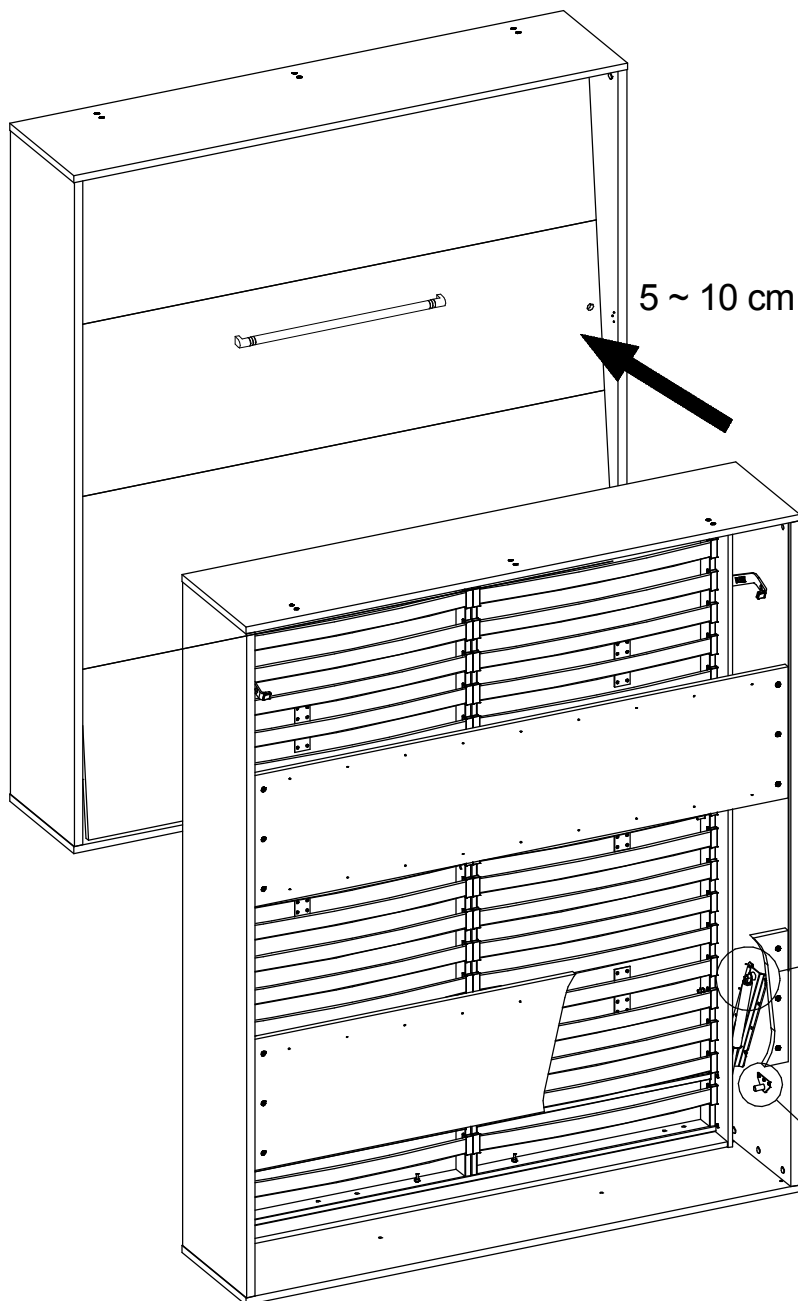
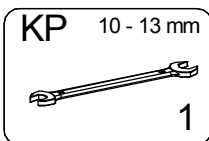
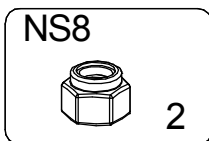
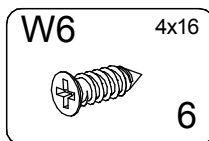
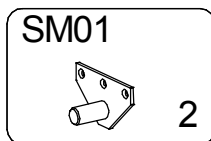

EN Inside view.
 PL Widok wewnętrzny

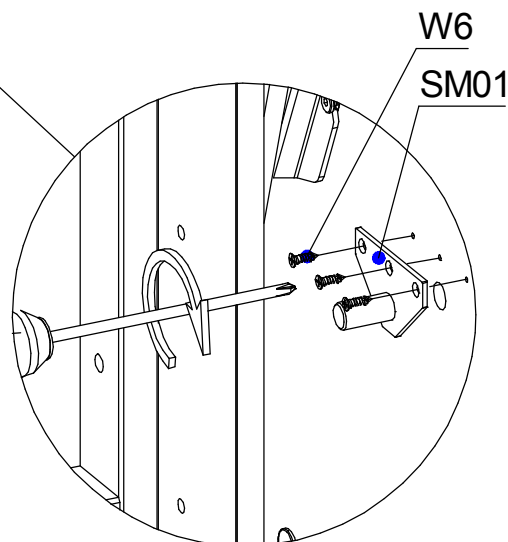

EN One person has to hold the front that the springs can be securely attached from the backside. Put ST on the top suspension of VM001. Fix ST with NS8. The INVENTO bed can only be opened after attaching the gas springs and mounting to the wall.

PL Jedna osoba musi przytrzymać front, aby sprężyny można było bezpiecznie zamocować od tyłu. Umieścić ST na górnym zawieszeniu VM001. Zamocować ST za pomocą NS8. Łóżko INVENTO można otworzyć dopiero po zamontowaniu sprężyn gazowych i przymocowaniu łóżka do ściany.

► **25** EN You will need the following hardware to complete this step:
PL Niezbędne do montażu :

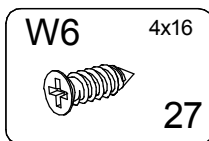
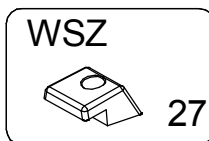
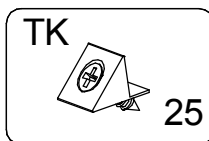

EN Length 1 = Length 2
PL Długość 1 = Długość 2

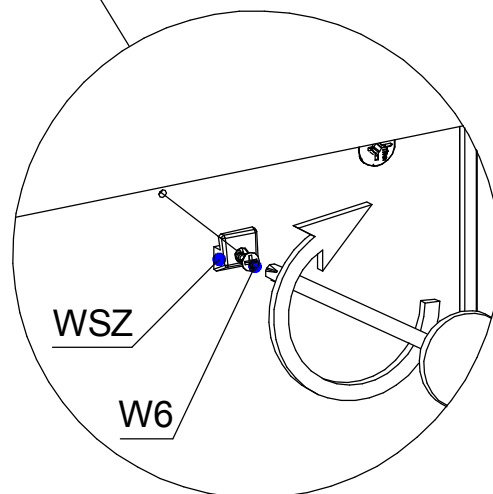
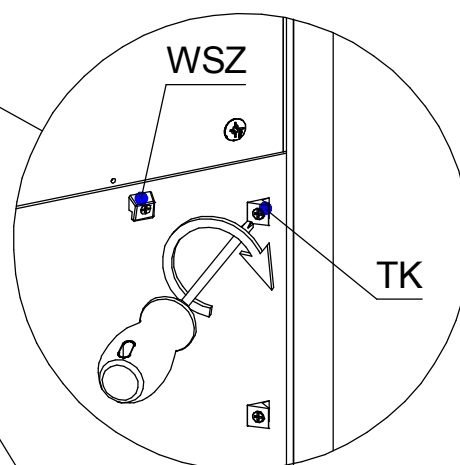
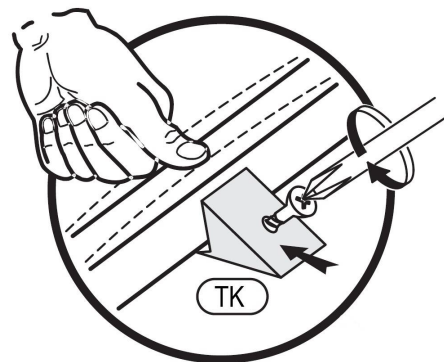
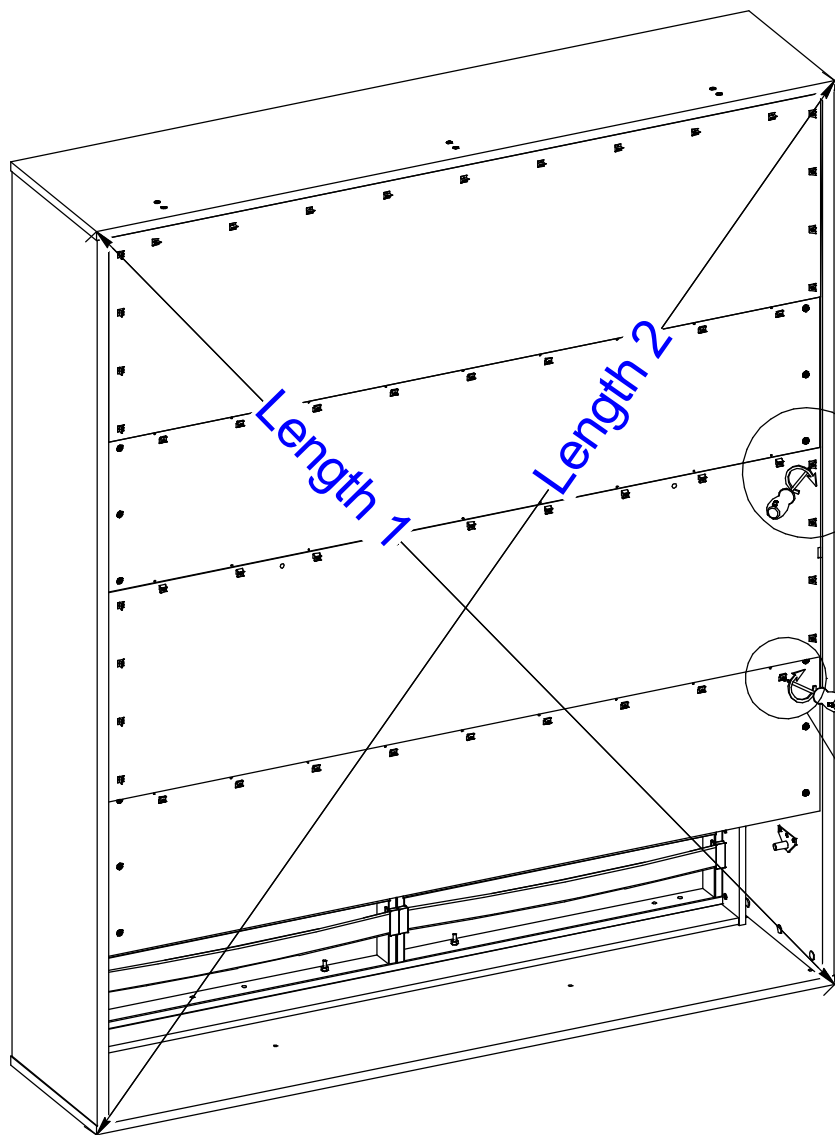

► **26** EN You will need the following hardware to complete this step:
 PL Niezbędne do montażu :

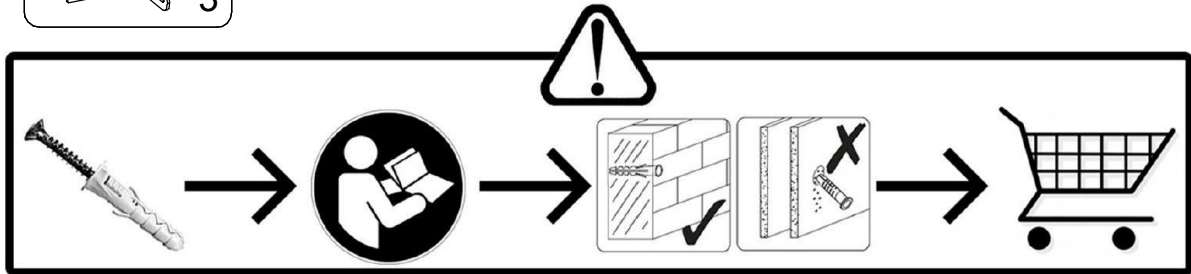
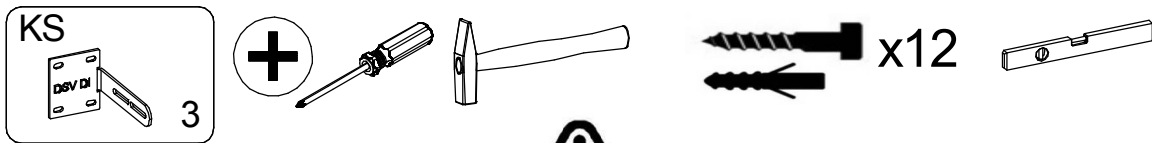

EN Screws, dowels for the wall (not included in the delivery).
 Size and type should be adapted to the wall consistency.

PL Wkręty i kołki rozporowe do ściany (nie są przewidziane w dostawie).
 Rozmiar i rodzaj kołków wyznacza się w zależności od typu ściany.
 Mocowanie do ściany "KS" musi być zamontowane za pomocą odpowiednich kołków rozporowych.

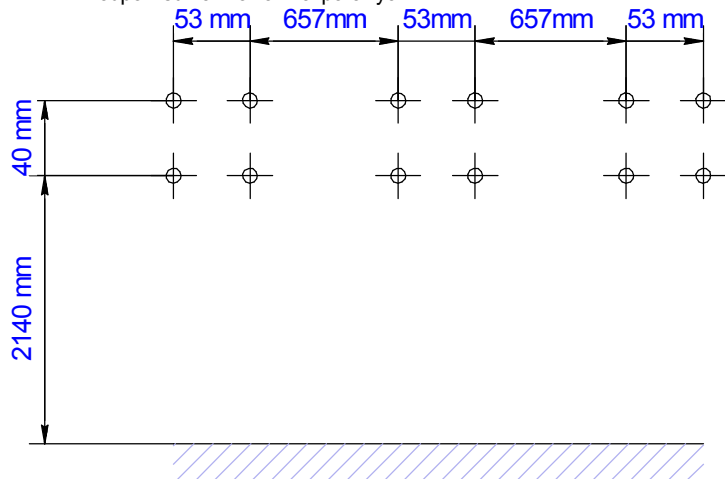
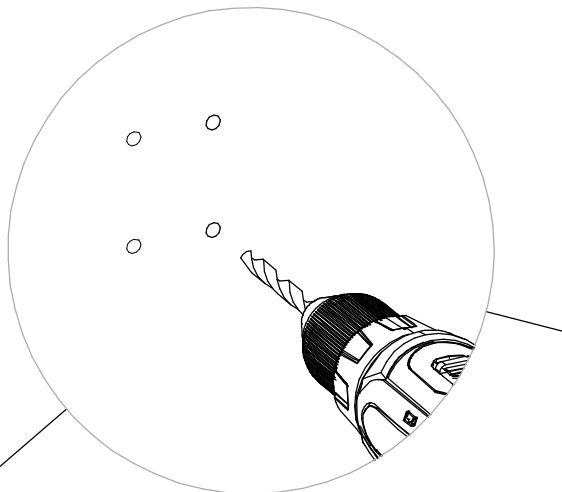

EN The wall mount «KS» has to be mounted with suitable dowels, on the wall.

PL Mocowanie do ściany «KS» należy zamontować za pomocą odpowiednich kołków rozporowych, dopasowanych do rodzaju ściany.

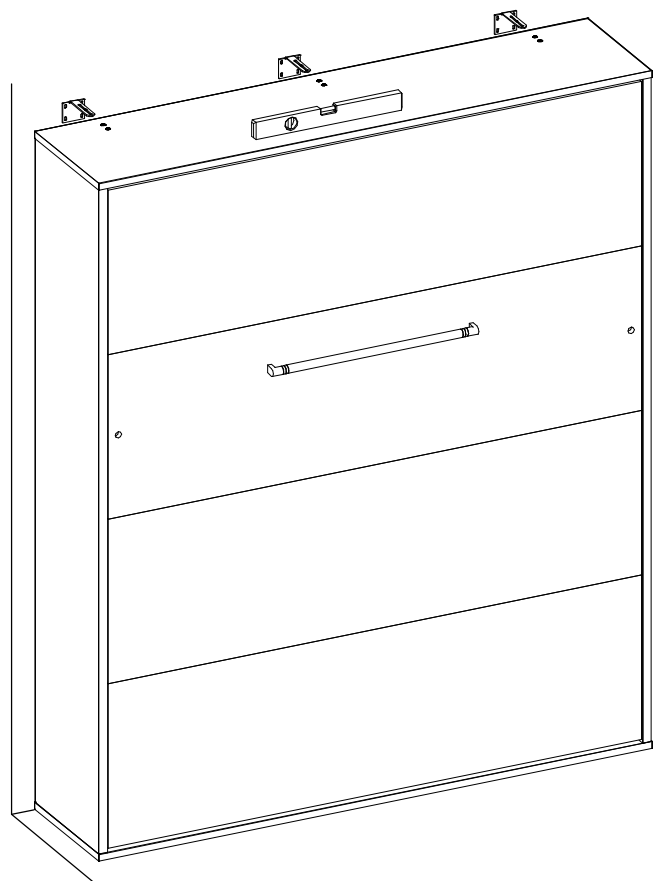
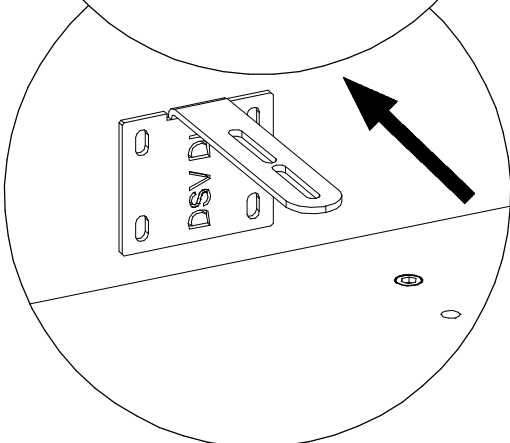
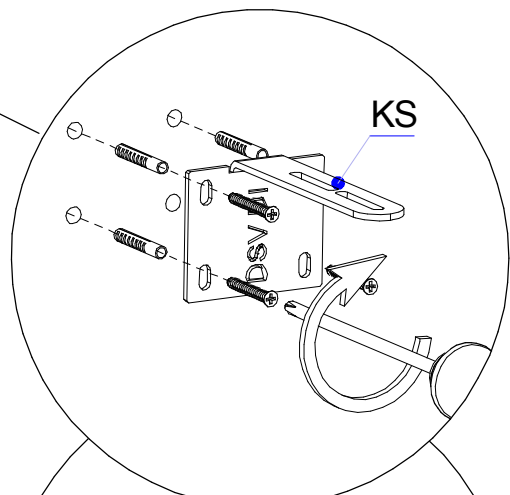

► **27** EN You will need the following hardware to complete this step:
PL Niezbędne do montażu :

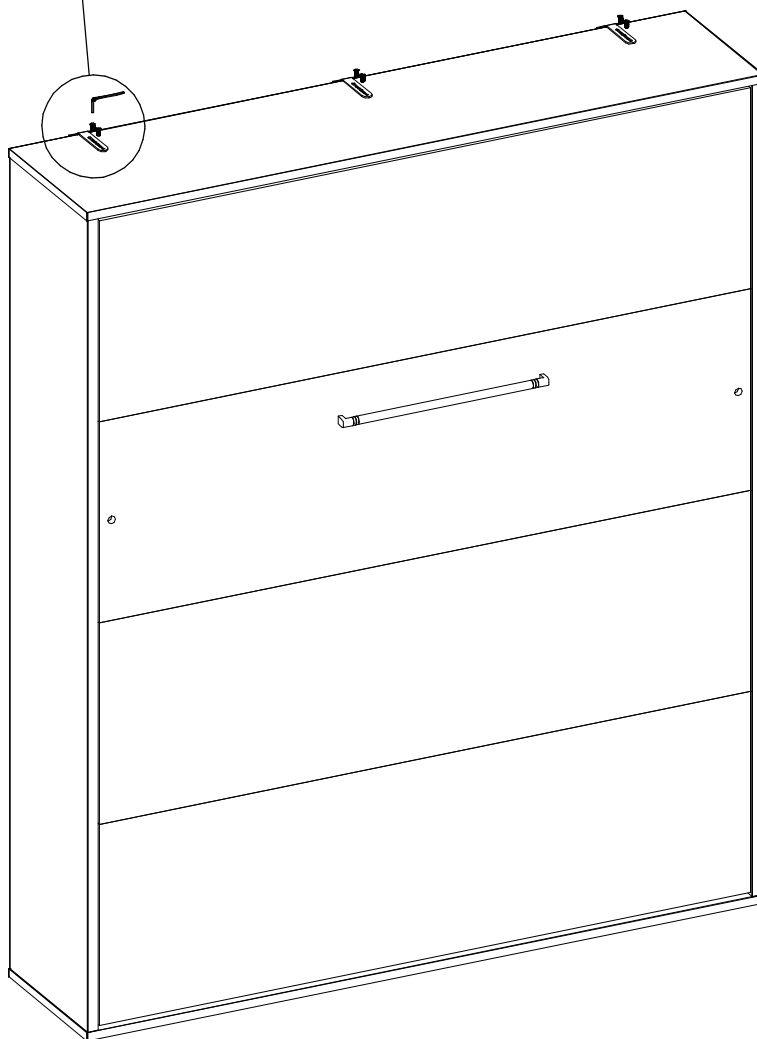
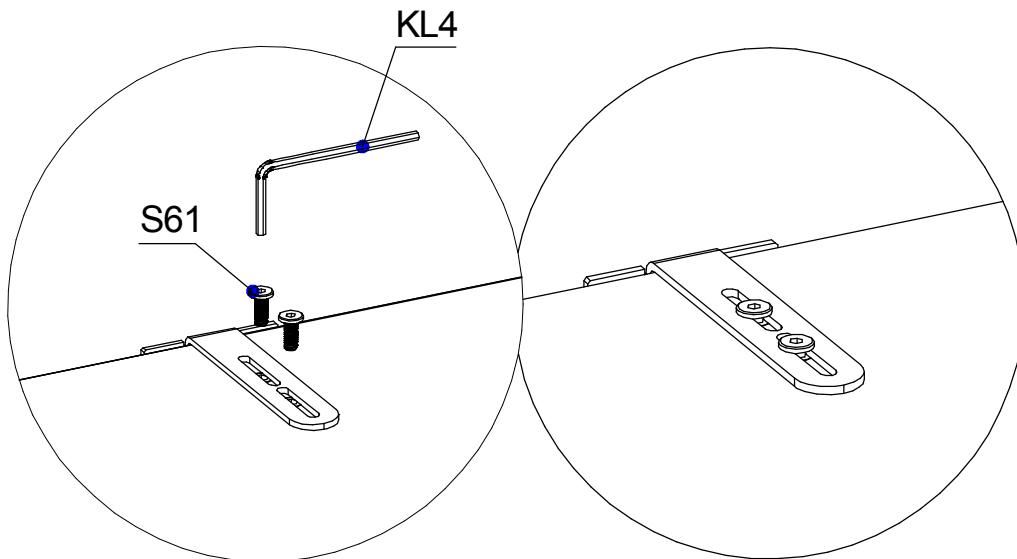
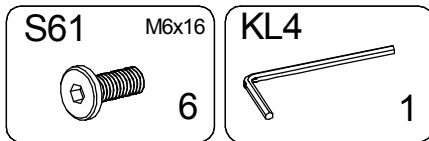







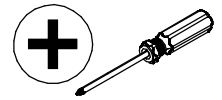

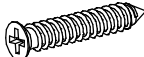

EN A person must hold the corpus before the front can be folded out.

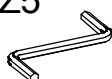
PL Osoba musi trzymać korpus w trakcie montażu.

►28 EN You will need the following hardware to complete this step: PL Niezbędne do montażu :



ZAF  2	W6 4x16  6	W9 4x30  4	NA14 f14  4	KZ5  1	N-S50 M8x16  4
ZAB  2	ZAC  2	25  1	P8  2	N-NK8 M8  4	

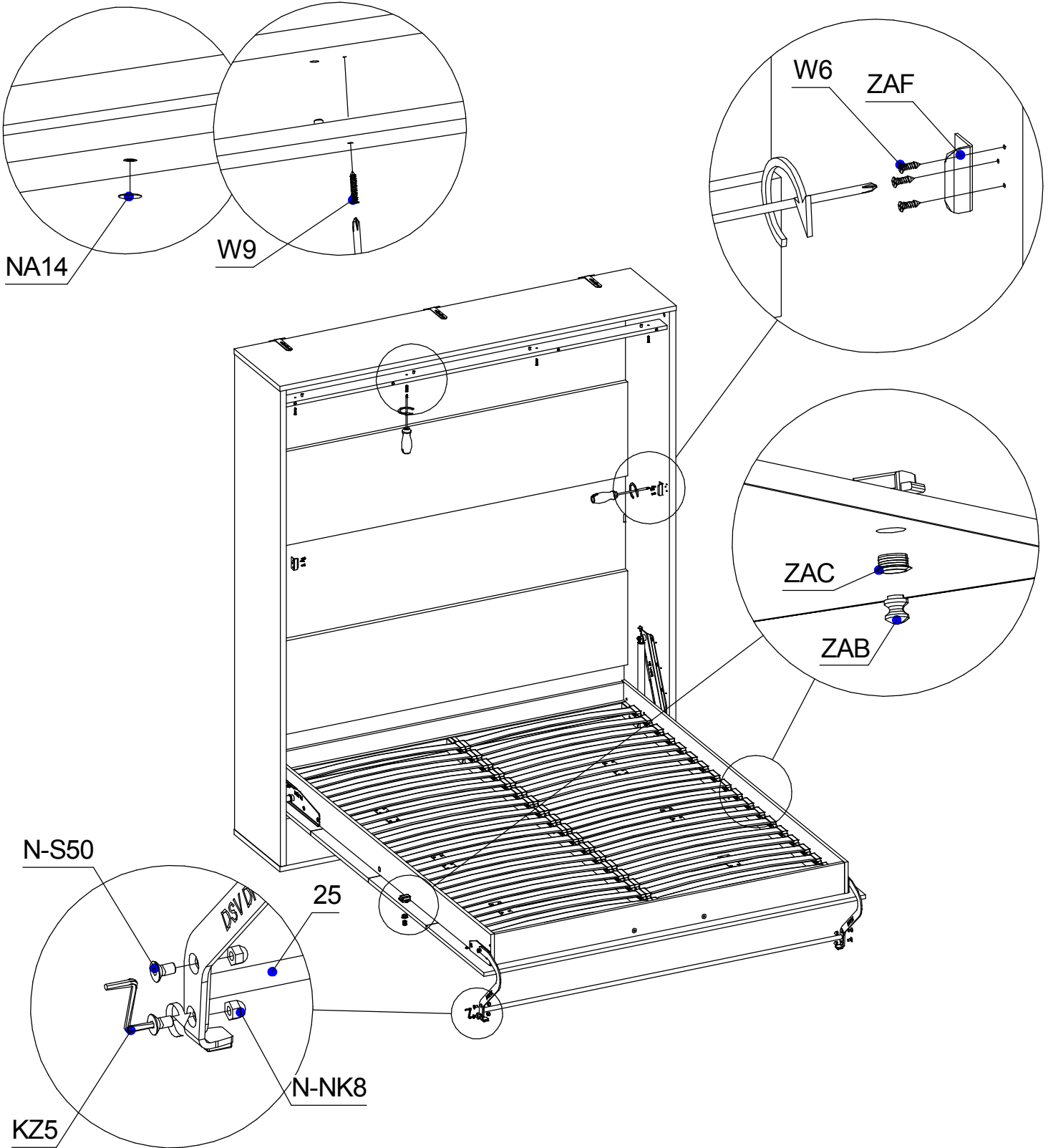

►29 EN You will need the following hardware to complete this step: PL Niezbędne do montażu :

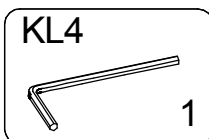
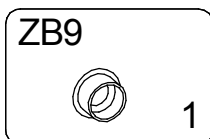
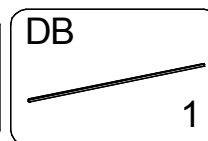
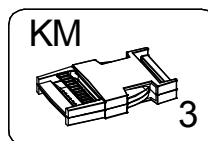
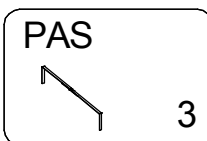
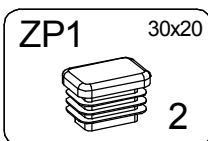
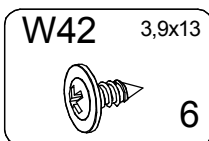
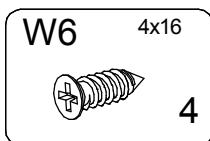

EN Inside view. Part DB is mounted directly behind Part 07.21.
PL Widok wewnętrzny. Element DB zamontować bezpośrednio za elementem 07.21.

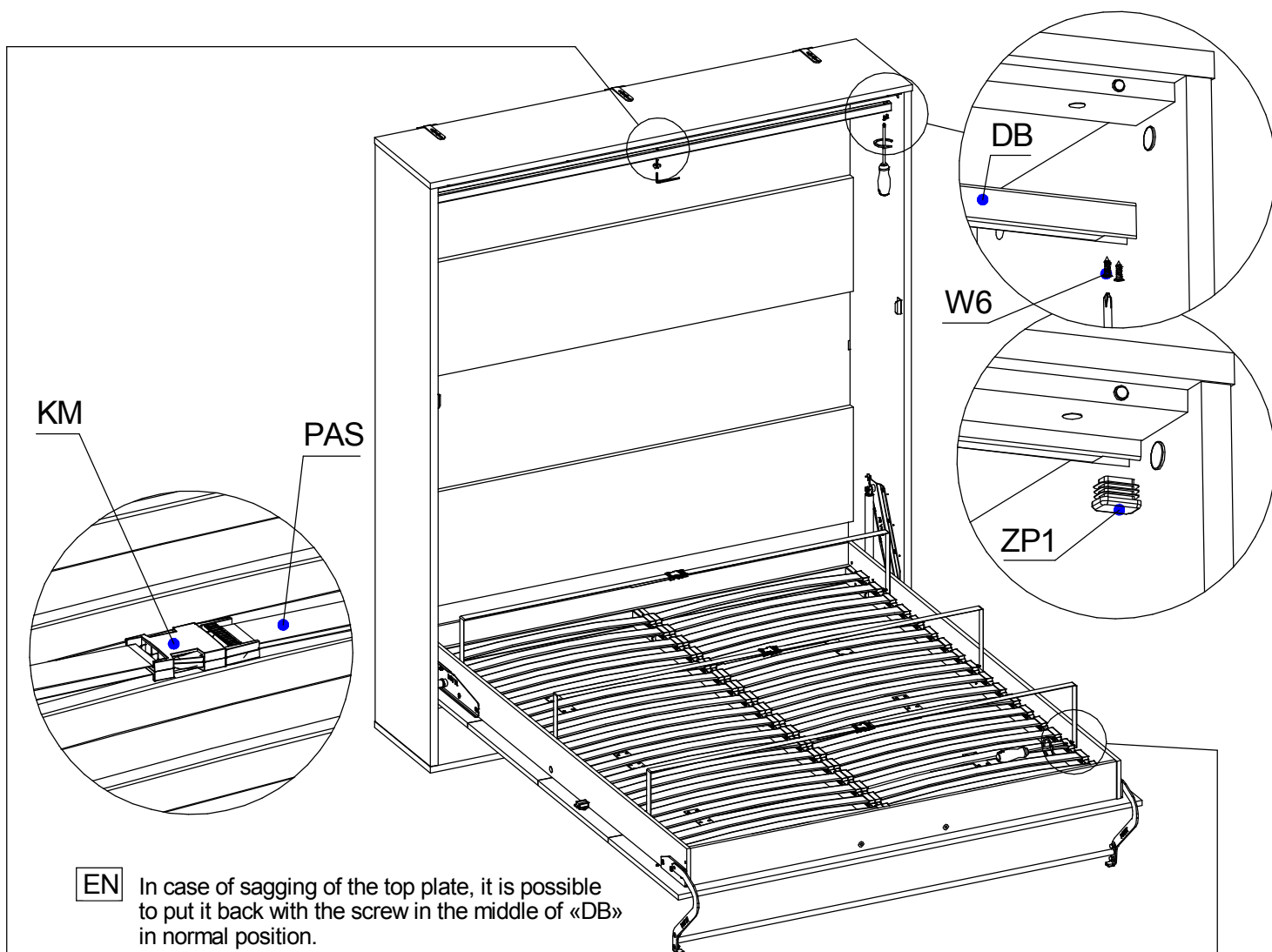

EN In case of sagging of the top plate, it is possible to put it back with the screw in the middle of «DB» in normal position.

PL W przypadku wygięcia górnej płyty korpusu jest możliwa regulacja jej poziomu za pomocą śruby znajdującej na środku profilu "DB".

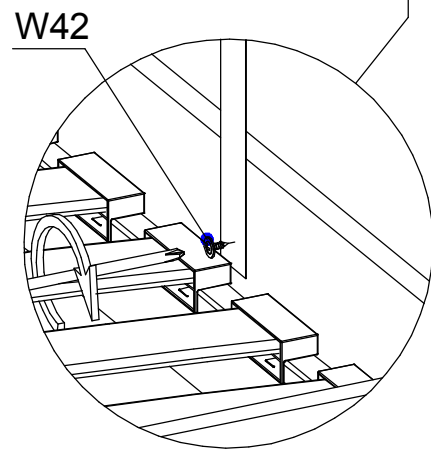
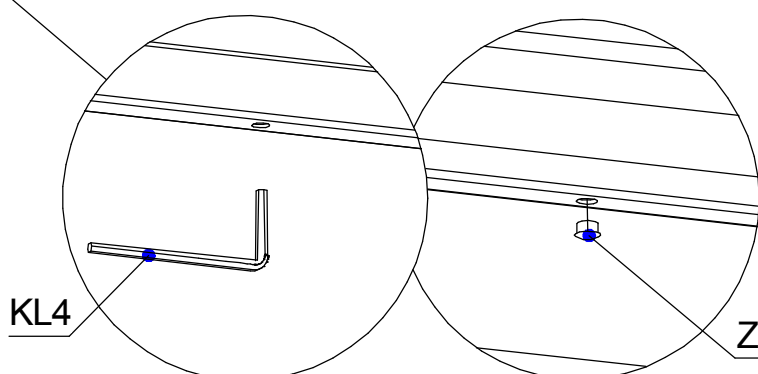

► **30** EN You will need the following hardware to complete this step:
PL Niezbędne do montażu :

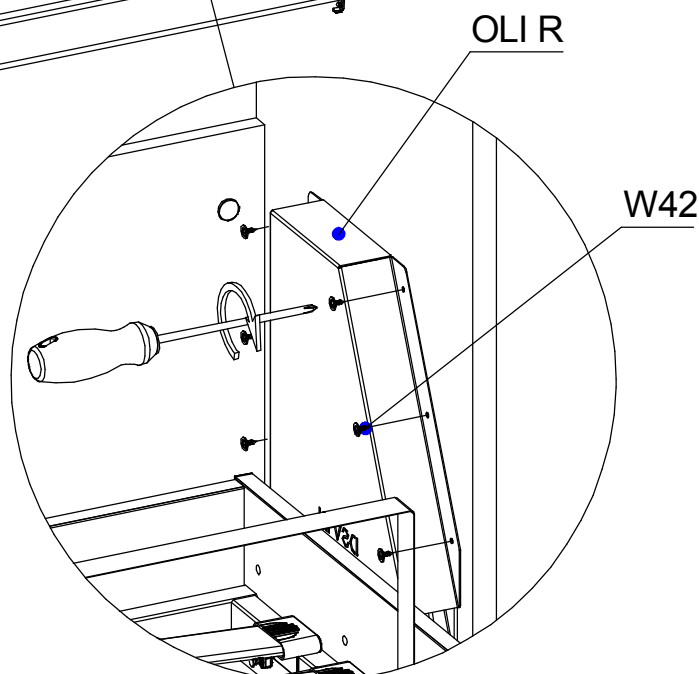
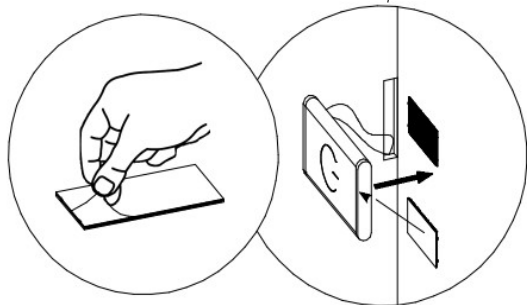
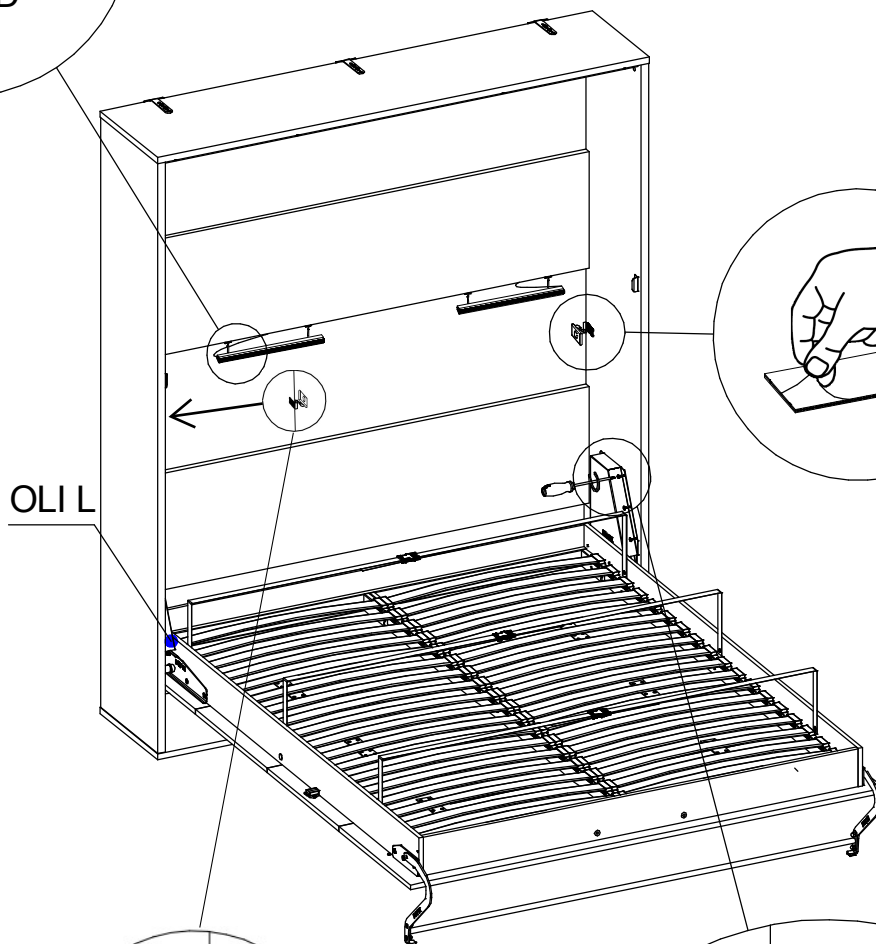
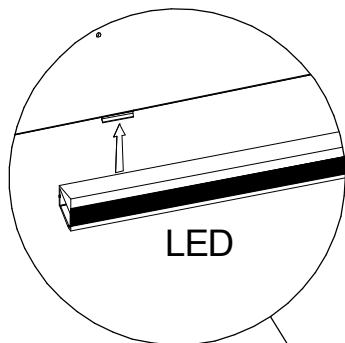
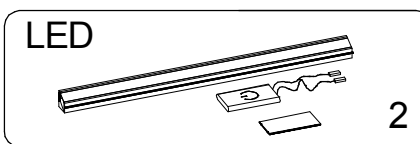
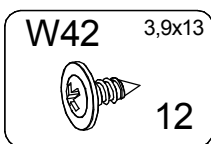
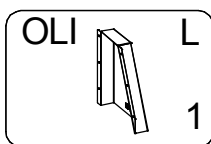
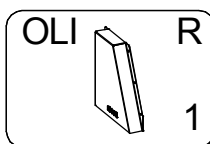

► **31** EN You will need the following hardware to complete this step:
PL Niezbędne do montażu :

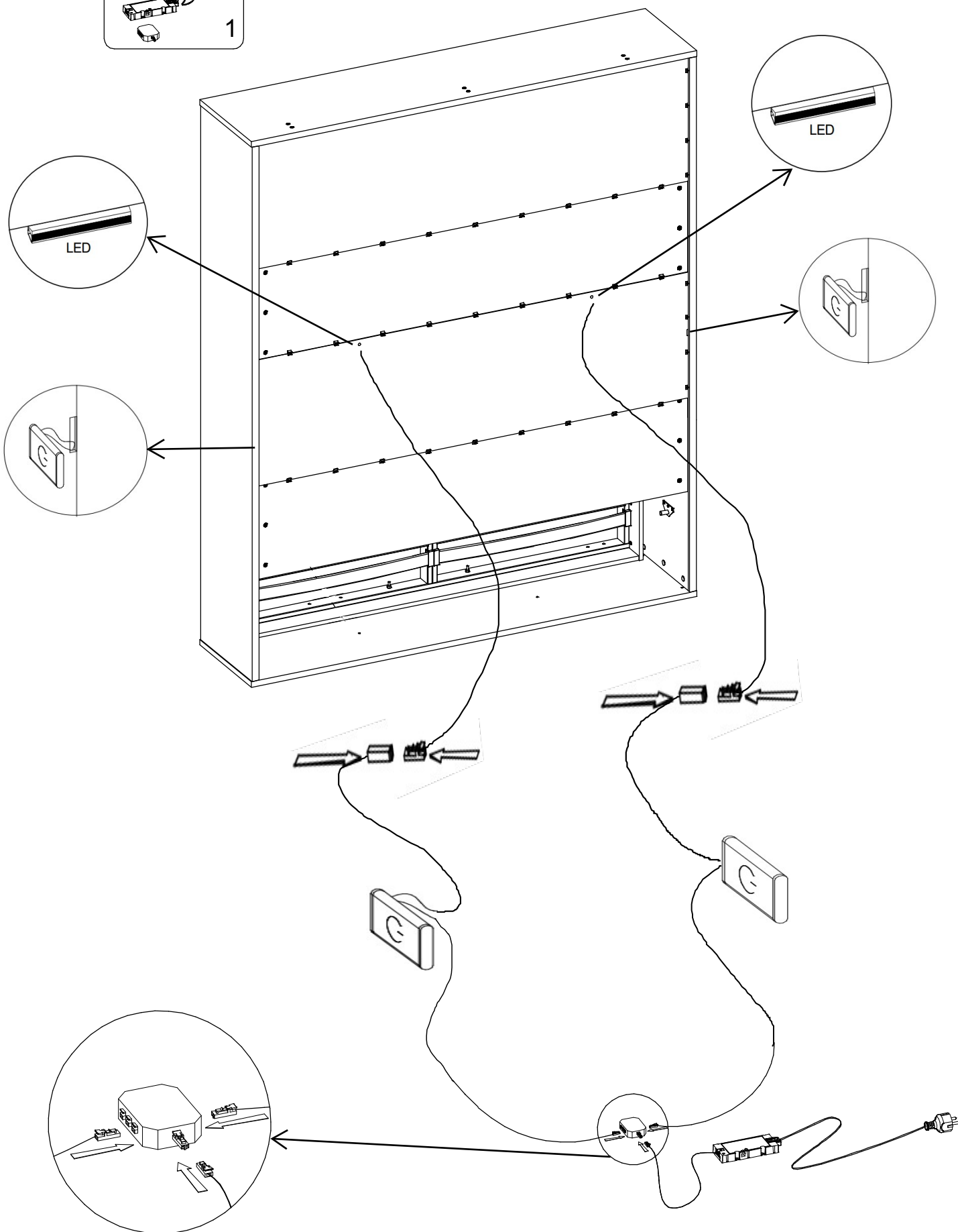
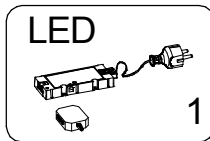

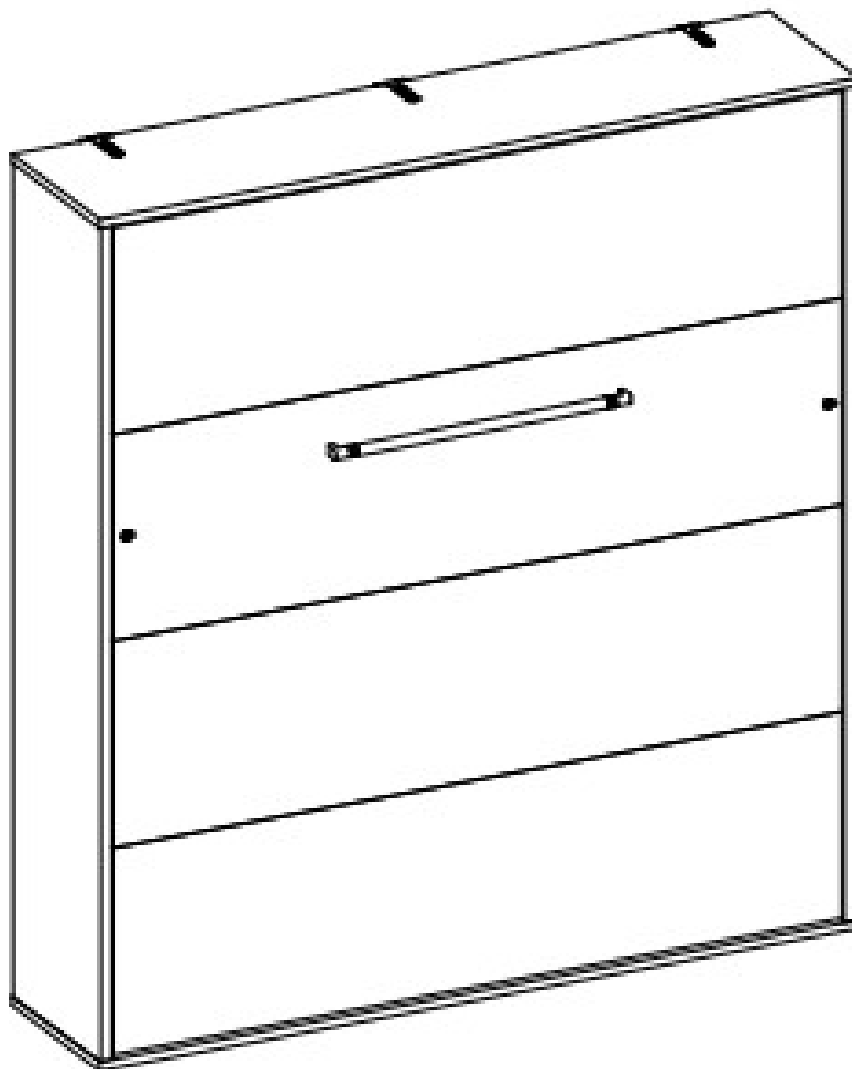

[EN]

Attention!
Please use only dust cloth or damp cloth
for cleaning (no microfiber cloths).
DO NOT use abrasive cleaning agents!
Attention!
INVENTO could close by itself without
mattress!

[PL]

Uwaga!
Do czyszczenia używać tylko specjalnej szmatki
do czyszczenia mebli (nie szmatkę z mikrofibry).
NIE używać ostrych środków czyszczących!
Uwaga!
Istnieje ryzyko samodzielnego zamknięcia łóżka
INVENTO bez materaca!