

# OLIVETTA ROUND WOOD DINING TABLE

DESIGN# SFV2201

Assembly Instructions

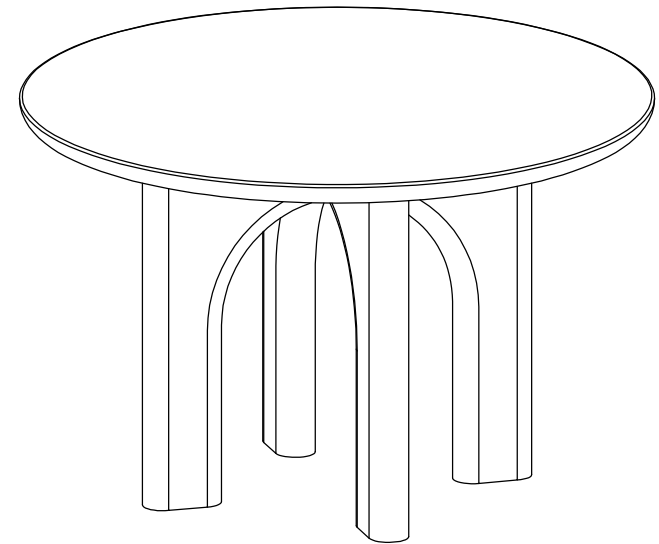

Need help?  
Feel free to contact us via email or call  
if you have any specific questions!





**contact us:**  
[cs@safavieh.com](mailto:cs@safavieh.com)  
866-422-9070

**SAFAVIEH**  
C O U T U R E





# Thanks for bringing Safavieh Couture into your home

Everything we make is incredibly simple to set up, including your new dining table. You won't need any additional tools.

## Parts List

- A X 1  
Table Top 
- B X 2  
Shorter Leg 
- C X 2  
Longer Leg 
- D x 4  
Mounting Plate 

## Hardware List

- HW1 x 32  
Hex Socket Bolt 5/16"-18 x 1.25" 
- HW2 x 1  
Crisscross metal plate 160\*160mm 
- HW3 x 6  
Dowels Ø10 x 30mm 
- HW4 x 1  
Allen Key M4 

1

Insert 2 of the dowels (HW3) into 1 of the longer legs (C). Insert the other end of the 2 dowels (HW3) into the second longer leg (C) as shown.

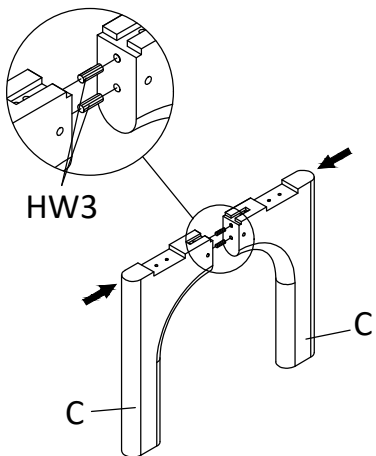

2

Insert the 4 remaining dowels (HW3) into the 2 shorter legs (B). Insert the other end of the dowels into the holes on the sides of the assembled longer legs as shown.

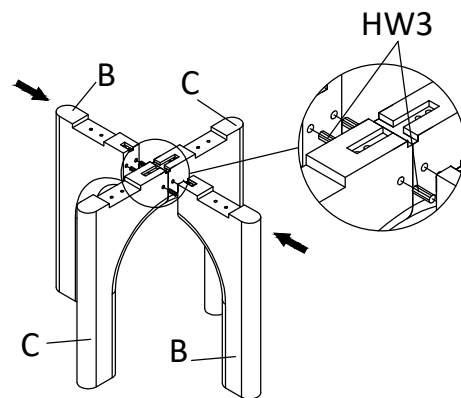

3

Align the screw holes on the crisscross metal plate (HW2) to the screw holes on the top of the assembled legs. Use the Allen key (HW4) to screw in 8 of the Hex Socket bolts (HW1) as shown.

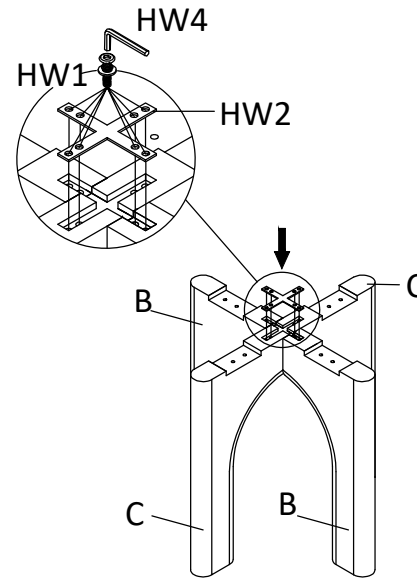

5

Place the table top (A) upside down on a soft surface. Align the screw holes on the table top (A) to the screw holes on the mounting plates (D). Use the Allen key (HW4) to screw in the rest of the Hex Socket bolts (HW1) as shown.

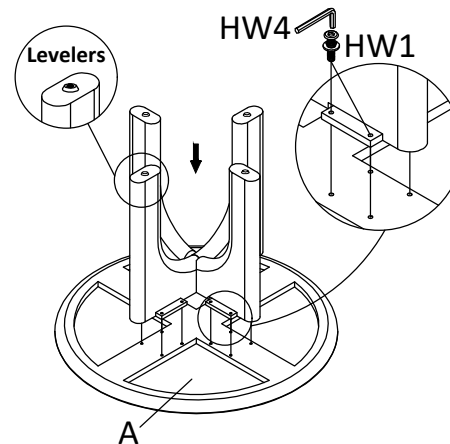

4

Align the center screw holes on the mounting plates (D) to the screw holes on the top of the legs. Use the Allen key (HW4) to screw in 8 of the Hex Socket bolts (HW1) as shown.

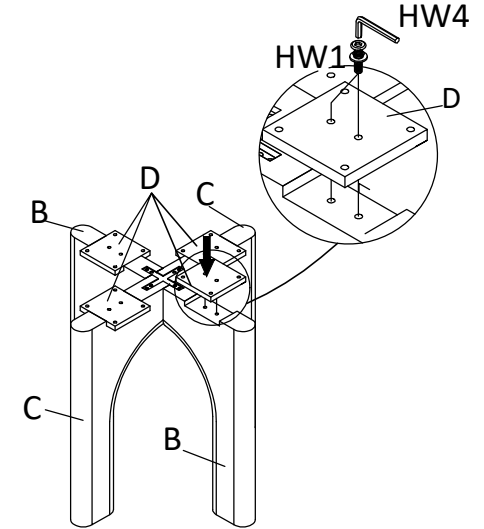

6

Turn the table upright. Use the levelers on the bottom of the legs to adjust the table as needed to make it level. Place the dining table in the place where you will use it. We'd love to see it - just tag us (we're @safavieh) and use the hashtag #safavieh on Instagram!

