

Assembly Instructions

We have designed our furniture with you, the customer in mind. Our clear, easy to follow, step by step instructions will guide you through the project from start to finish. Feel confident that this will be a fun and rewarding project. The final product will be a quality piece of furniture that will go together smoothly and give years of enjoyment.

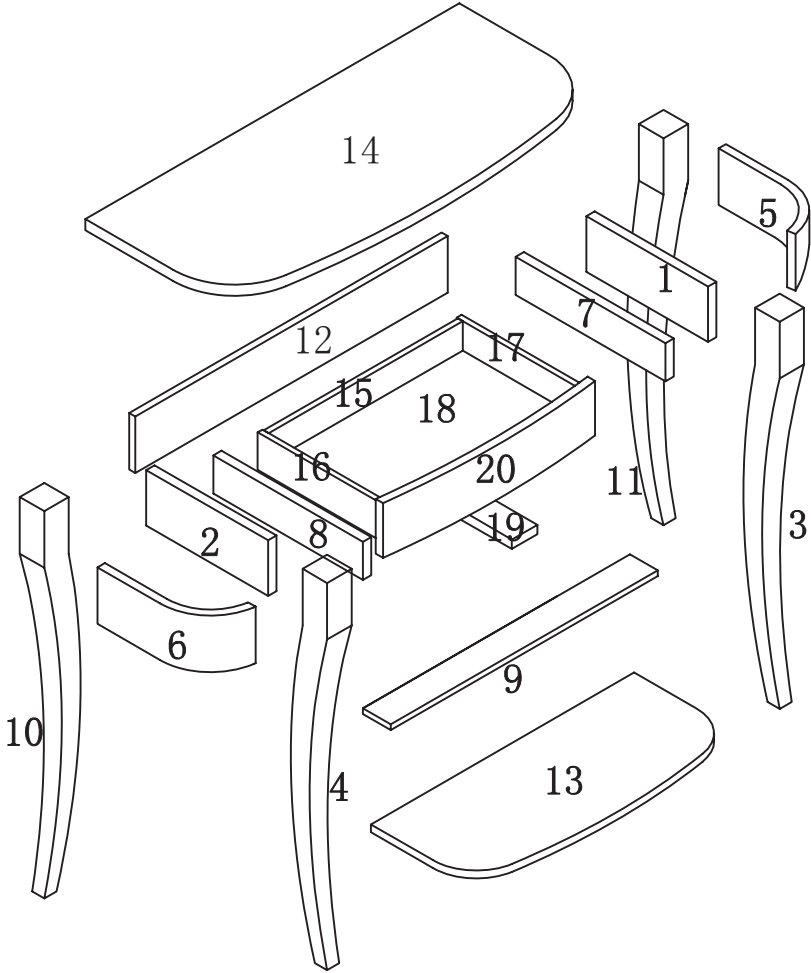









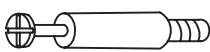

PARTS IDENTIFICATION

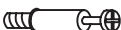

Please count and verify all parts before assembly

(1)	1pc	(8)	1pc	(15)	1pc
(2)	1pc	(9)	1pc	(16)	1pc
(3)	1pc	(10)	1pc	(17)	1pc
(4)	1pc	(11)	1pc	(18)	1pc
(5)	1pc	(12)	1pc	(19)	1pc
(6)	1pc	(13)	1pc	(20)	1pc
(7)	1pc	(14)	1pc		

HARDWARE IDENTIFICATION

A		Large Cambolt	L29	28pcs
B		Large Camlock	ø15	28pcs
C		Large Dowel	ø8 × 25	19pcs
D		Medium Screw	ø4 × 30	8pcs
E		Small Cambolt	L20	4pcs
F		Small Camlock	ø12	4pcs
G		Small Screw	ø4 × 25	8pcs
H		Large Screw	ø4 × 35 (BK)	4pcs
I		Small Dowel	ø6 × 30	2pcs
J		Foot Pin	ø16	4pcs
K		Bracket	28 × 20 × 20 (BK)	4pcs
L		Bracket Screw	ø3 × 14 (BK)	16pcs
M		Glue	Glue: For securing please apply to wood dowel first before inserting into panel	1pc

Assembling the unit with camlocks and wood dowels.

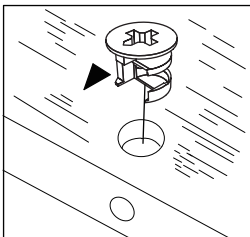
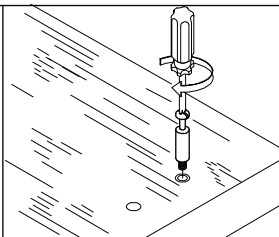
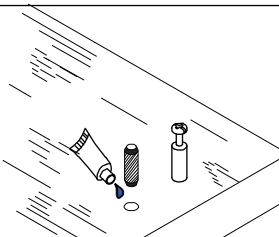
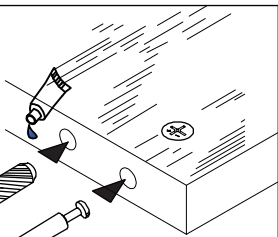
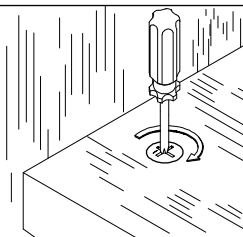
				
Insert camlock, camlock must face bolt hole	Gently screw cam dowel into the threaded anchor	Lightly glue one end of wood dowel and tap into hole.	Lightly glue dowel and connect to second panel by inserting dowels into holes	Gently screw the cam clockwise into locked position. Do not overtighten.

Step1

1.Attach hardware to pieces as shown.

2.Attach (1) to leg (3) and leg (4) using care not to overtighten camlocks.

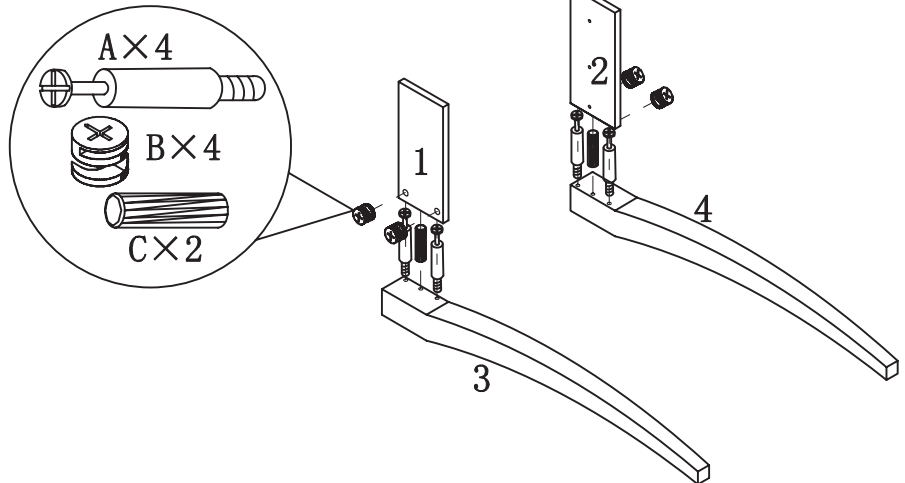

NOTE:

*REFER TO PAGE 3 FOR CAMLOCK INSTRUCTIONS.

Step2

Screw (5) and (6) into leg assemblies using screws (D) .

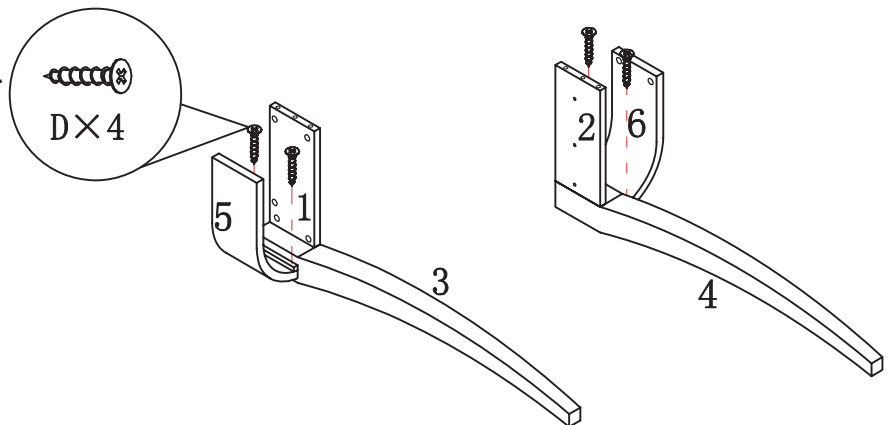

Step3

1.Screw (8) and (7) into leg assemblies with screws (G).

2.Connect assemblies together with (9) and camlocks,using care not to overtighten.

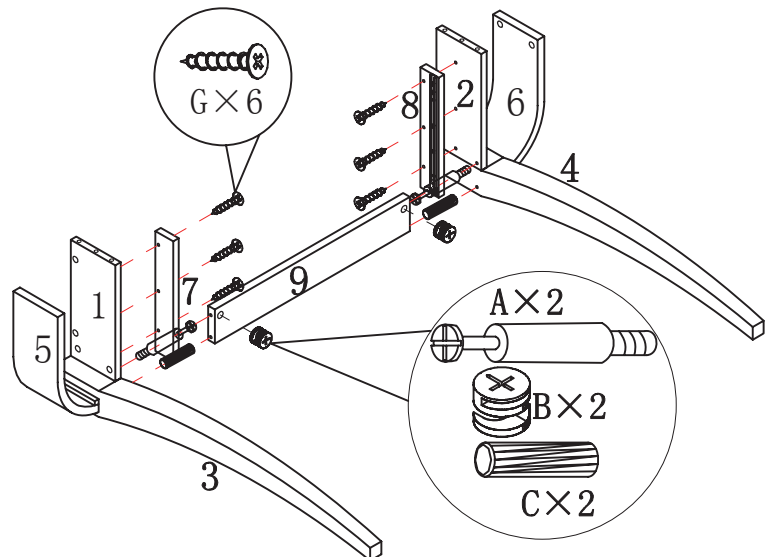

Step4

REAR LEG ASSEMBLY

Connect legs (10) and (11) to back panel (12) with camlocks, be careful not to overtighten.

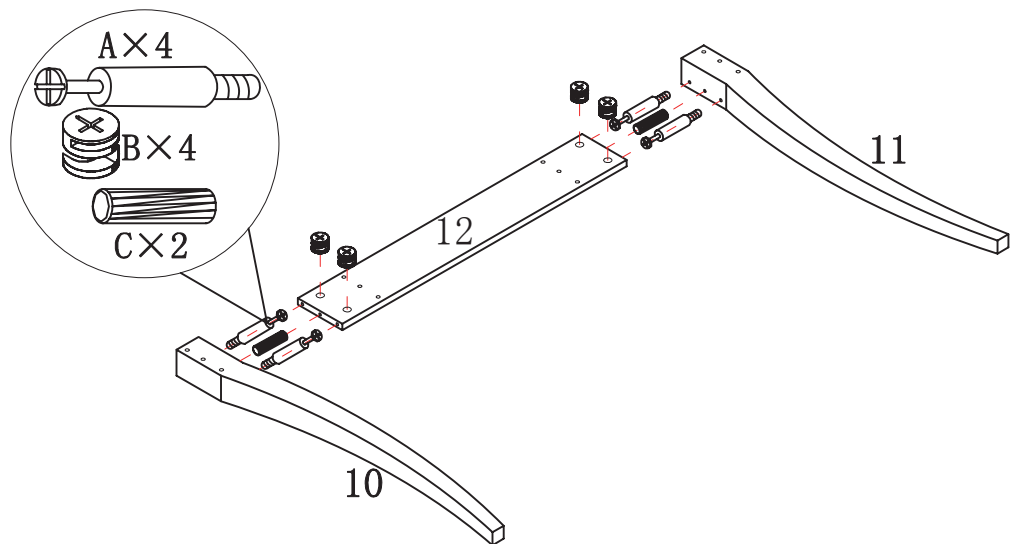

Step5

1. Attach hardware to rear leg assembly.

2. Insert camlocks into front leg assembly.

3. Connect front and rear assemblies together with camlocks and large screws (H).

4. Turn unit upside down and gently hammer foot pins (J) into legs.

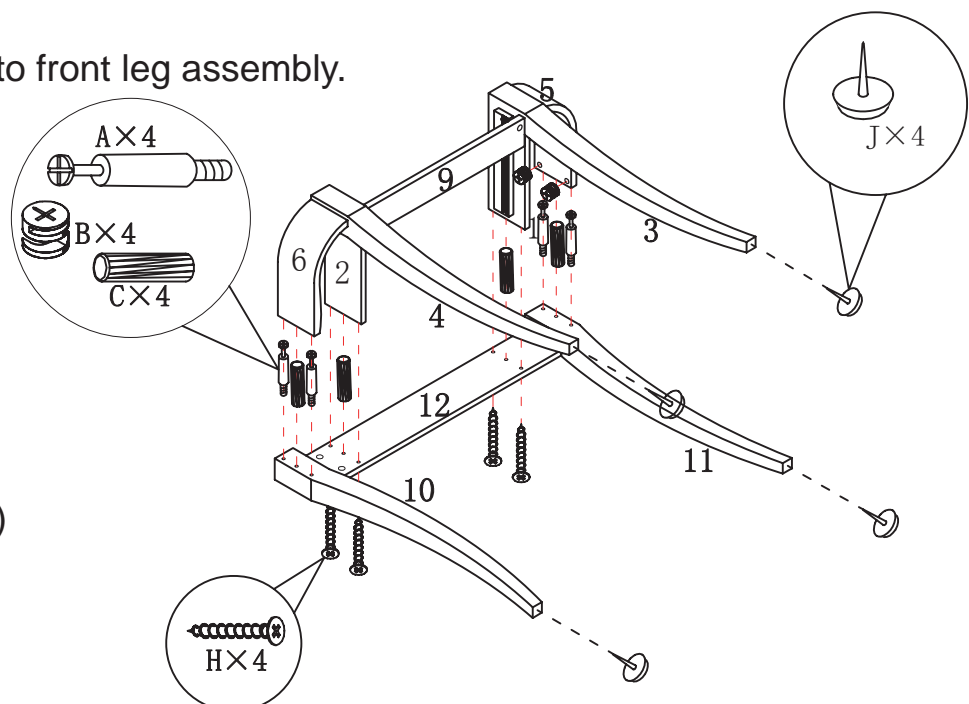

Step6

1. Attach hardware to tabletop (14) and insert camlocks into leg assembly.

2. Place top (14) onto assembly and gently tighten camlocks.

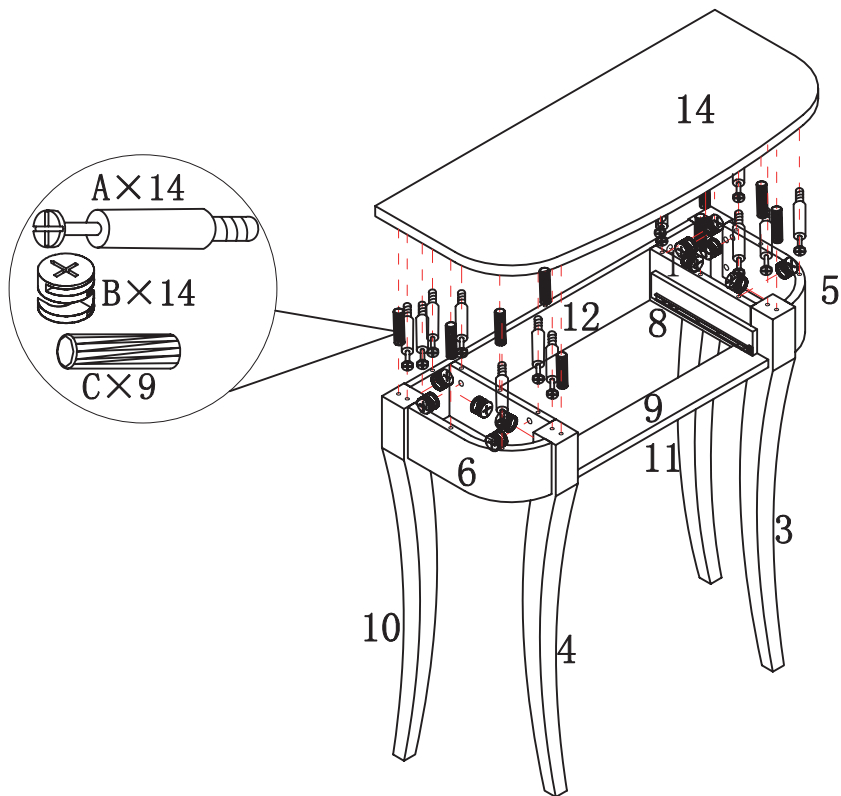

Step7

1. Turn unit upside down on carpet or soft surface.

2. Attach bottom shelf (13) to table using brackets (K) and barcket screws (L).

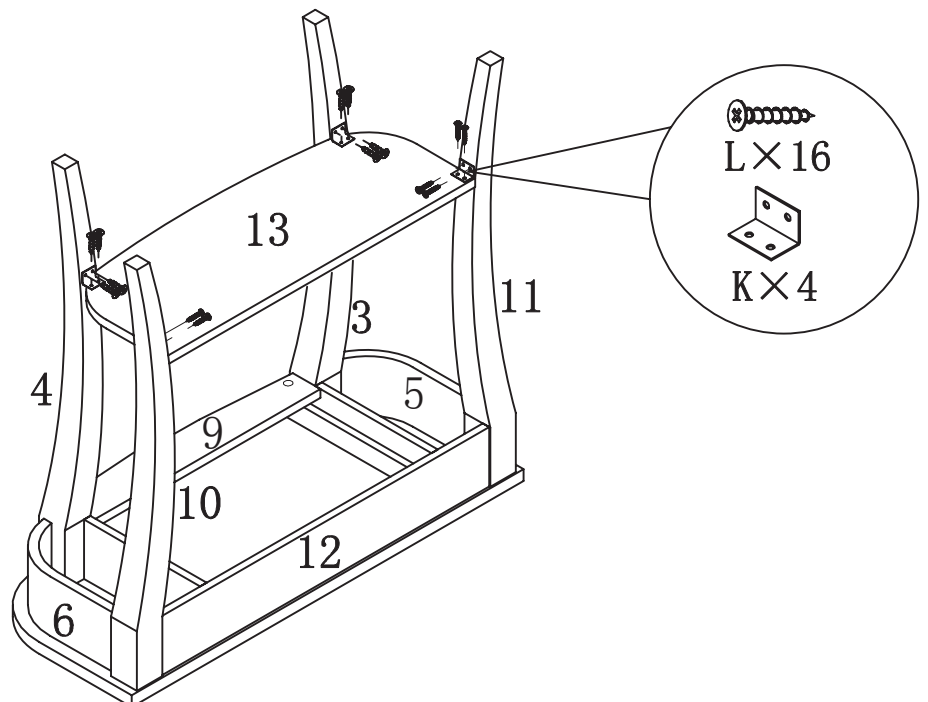

Step8

DRAWER ASSEMBLY

Carefully connect side panels (16)&(17) to back panel (15) using medium screws (D).

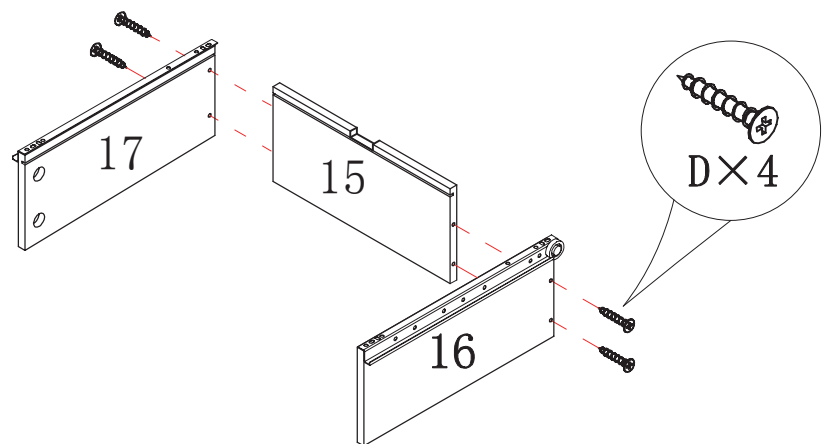

Step9

1. Slide drawer bottom panel (18) into grooves of drawer assembly.

2. Place support bar (19) over bottom panel (18) and connect with small screws (G).

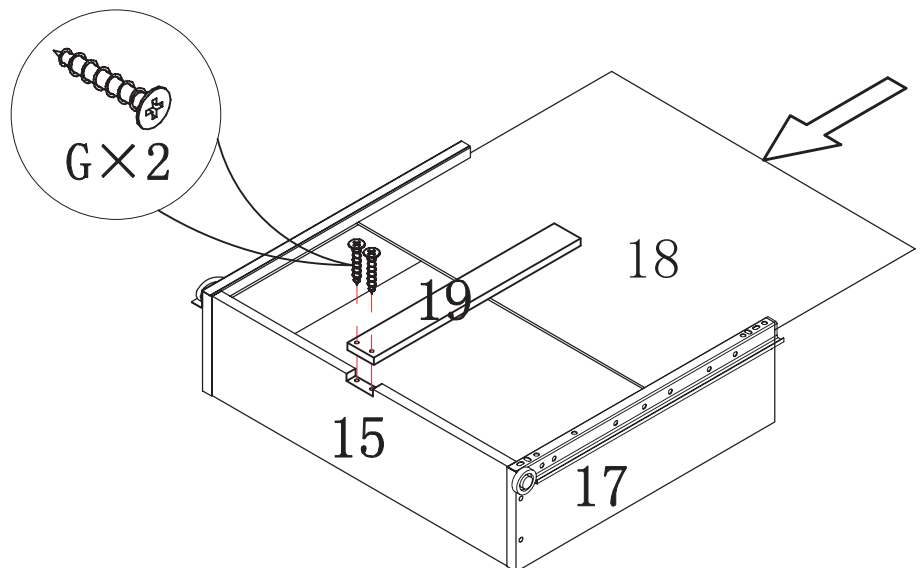

Step10

1. Attach hardware to drawer front panel (20) and insert camlocks into drawer sides.

2. Connect drawer front panel to drawer and tighten camlocks.

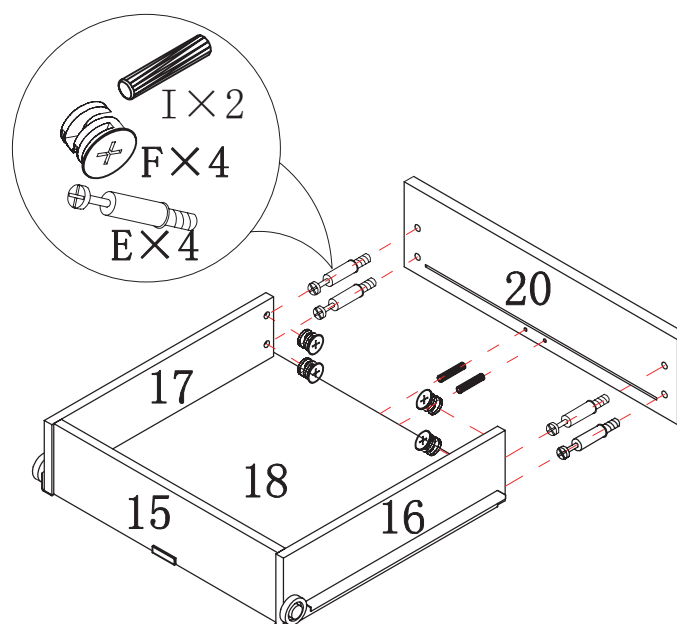

Step 11

Carefully slide drawer into table.

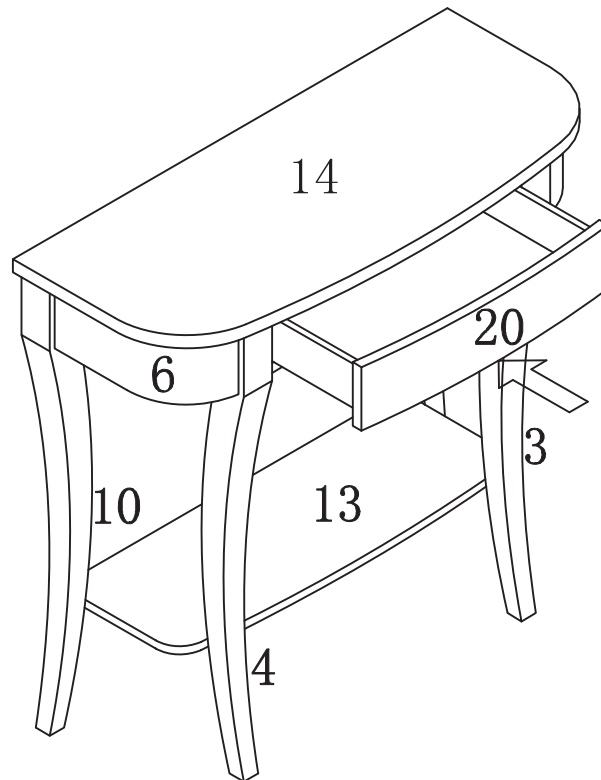

Enjoy your new quality piece of furniture.

