

# ASSEMBLY INSTRUCTION

**A** Table Top



1pc

**B** Leg

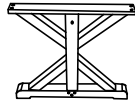

2pcs

**C** Side Rail

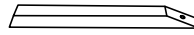

2pcs

**D** Middle Rail



1pc

**E** Reinforcing Bar

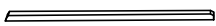

**F** Bolt  
Ø5/16"x1-1/2"



**G** Bolt  
Ø5/16"x2"



**H** Flat Washer  
Ø5/16"x22mm



**I** Lock Washer  
Ø5/16"x13mm



**J** Allen Key  
M5



**K** Bolt  
Ø5/16"x3-3/4"



**L** Half Moon Nut  
Ø5/16"



**M** Hex Nut  
Ø5/16"x1/2"x6mm



**N** Spanner  
Ø5/16"

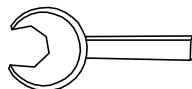

**O** Bolt  
Ø1/4"x2-1/4"



**P** Flat Washer  
Ø1/4"x19mm



**Q** Lock Washer  
Ø1/4"x11mm



**R** Allen Key  
M4



4pcs

1pc

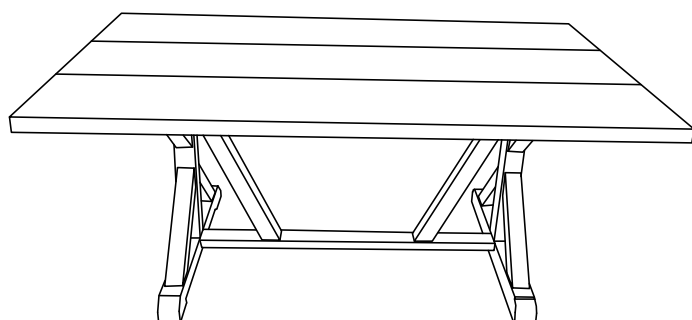

This page lists all the contents included in the box. Please take the time to identify the hardware as well as the individual components to this product. As you unpack and prepare for assembly, place the contents on a carpeted or padded area to protect them from damage.

- 1** Assembling Middle Rail (D) to Leg (B), rotate Bolt (K) to Leg (B) Firstly, then attach Middle Rail (D) to Leg (B) through Bolt (K). Next using Half Moon Nut (L) and Hex Nut (M) to lock with Bolt (K) by Spanner (N) as below shown.

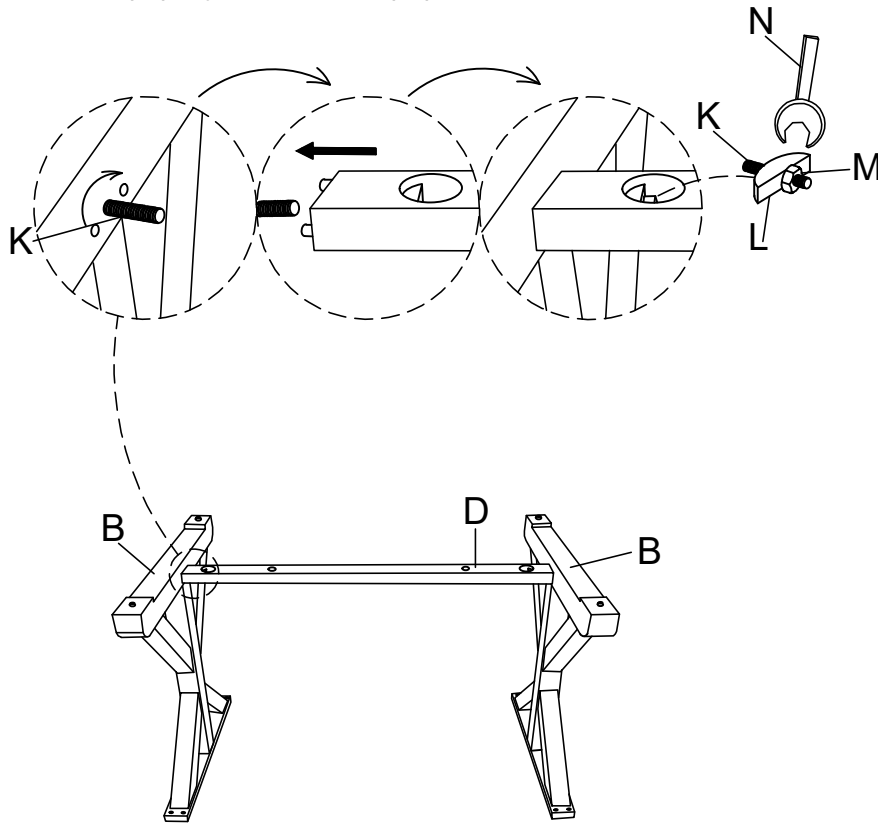

- 2** Attach the Side Rail (C) to the Middle Rail (D) & Leg (B) using Bolt (G), Lock Washer (I) & Flat Washer (H) by Allen Key (J) as below shown.

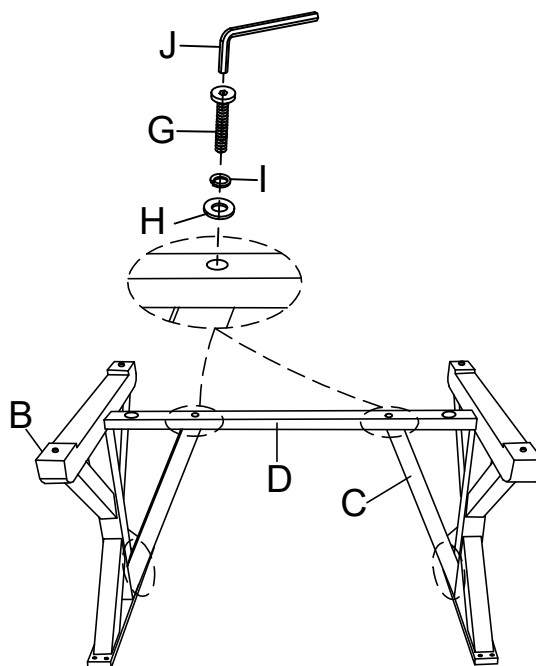

- 3** Attach pre-assembled Leg (B) to Table Top (A) using Bolt (F), Flat Washer (H) & Lock Washer (I) by Allen Key (J) as below shown. Then attach Reinforcing Bar (E) to Table Top (A) using Bolt (O), Flat Washer (P) & Lock Washer (Q) by Allen Key (R) as below shown.

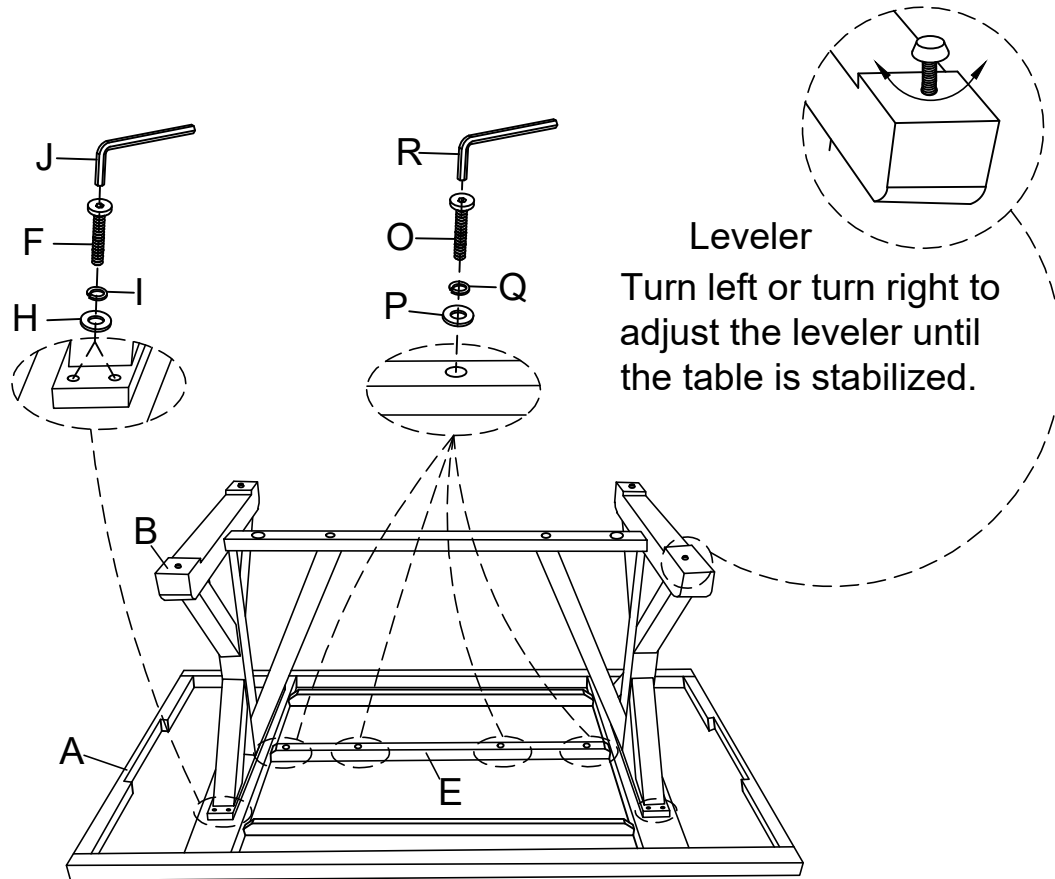

### Cleaning & Care

Treat surface with care. Surface is resistant to scratches but is not scratch resistant. Clean surfaces with a dry or damp soft cloth. Do not use abrasive cleaners. Hardware may loosen over time. Periodically check that all connections are tight.

# ASSEMBLY INSTRUCTION

**A** Chair Back

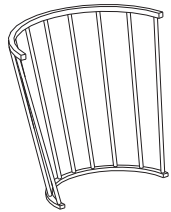

1 pc

**B** Left Leg

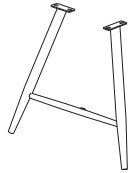

1 pc

**C** Right Leg



1 pc

**D** Seat



1 pc

**E** Center Cross Bar



1 pc

**F** Bolt with Lock Washer and Flat Washer  
1/4", 5/8"

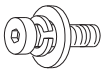

10 pcs

**G** Pan Head Bolt  
1/4", 1-3/4"



3 pcs

**H** Lock Washer  
Ø11



3 pcs

**I** Flat Washer  
Ø13



3 pcs

**J** Allen Wrench  
4mm

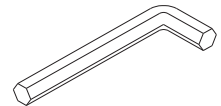

1 pc

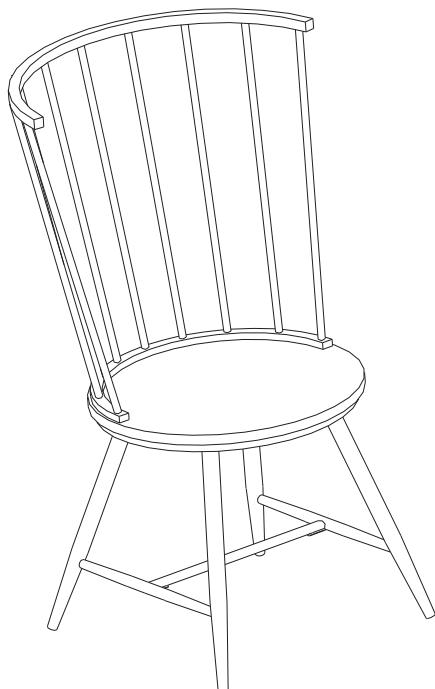

This page lists all the contents included in the box. Please take the time to identify the hardware as well as the individual components to this product. As you unpack and prepare for assembly, place the contents on a carpeted or padded area to protect them from damage.

- 1 Place and face down Seat ( D ) on a stable and smooth surface, attach Left Leg ( B ) and Right Leg ( C ) to the Seat ( D ) then tighten Bolt with Lock Washer and Flat Washer ( F ) with Allen Wrench ( J ).

Take the Allen Wrench, and turn the bolts until the legs are secure. **DO NOT TIGHTEN COMPLETELY.** Stop when you feel you are adding force to tighten the bolts.

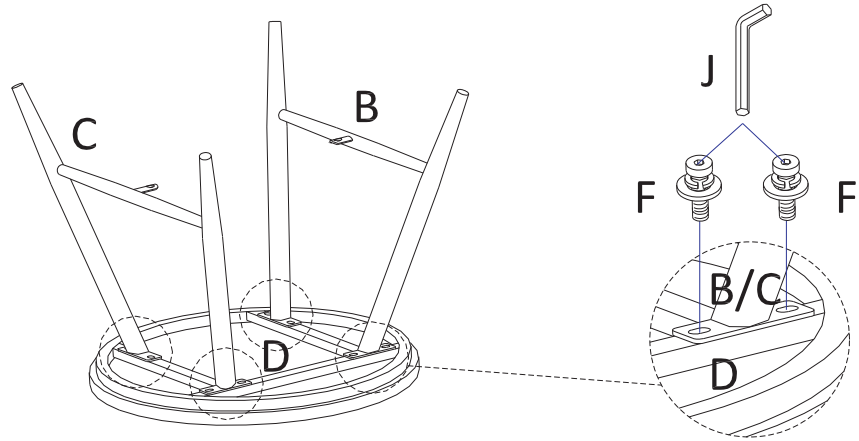

- 2 Align Center Cross Bar ( E ) to Left Leg ( B ) and Right Leg ( C ) then tighten Bolt with Lock Washer and Flat Washer ( F ) with Allen Wrench ( J ).

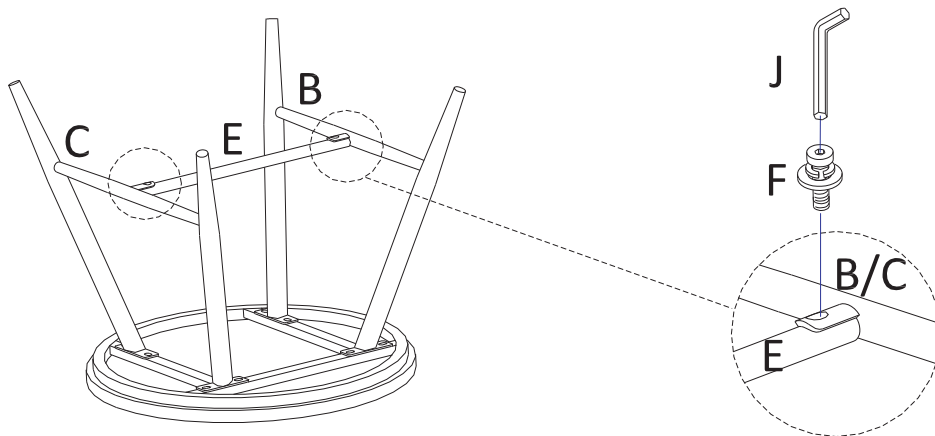

- 3** Place upright the assembled seat with legs, attach Chair Back ( A ) with Seat ( D ) then tighten with Pan Head Bolts ( G ), Lock Washer ( H ) and Flat Washer ( I ), using Allen Wrench ( J ).

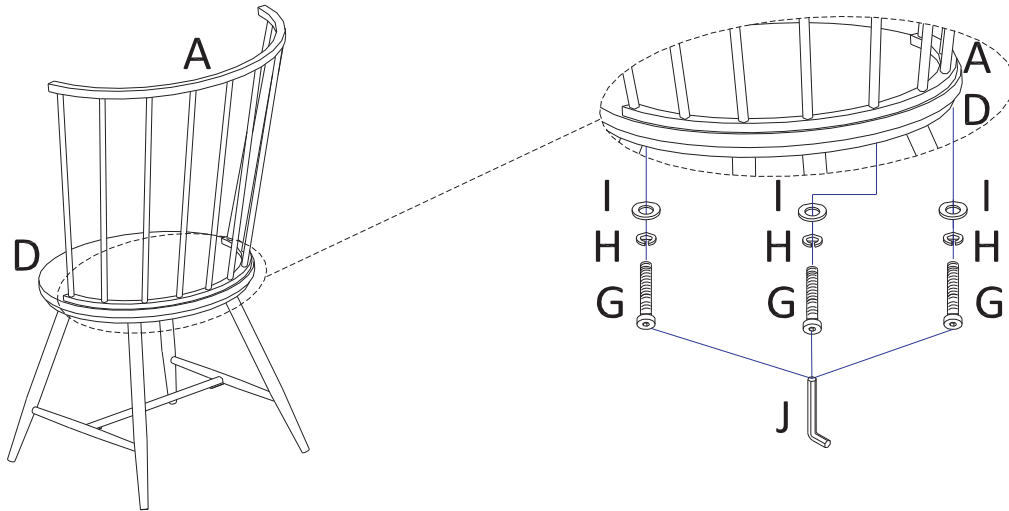

**Helpful Tip:**

-Instead of applying downward pressure while reaching under to tighten bolts, have someone sit in the chair while you tighten the bolts.

Stand chair up on an even surface and check that it is balanced. If there is a slight wobble, apply downward pressure in the corner where a leg is uneven. Keeping pressure in that corner, tighten all bolts.

If balanced, apply downward pressure evenly in the center and tighten all bolts.

Do not over-tighten beyond hole depth.

---

**Cleaning & Care**

Treat surface with care. Surface is resistant to scratches but is not scratch resistant. Clean surfaces with a dry or damp soft cloth. Do not use abrasive cleaners. Hardware may loosen over time. Periodically check that all connections are tight.