

# ASSEMBLY INSTRUCTIONS

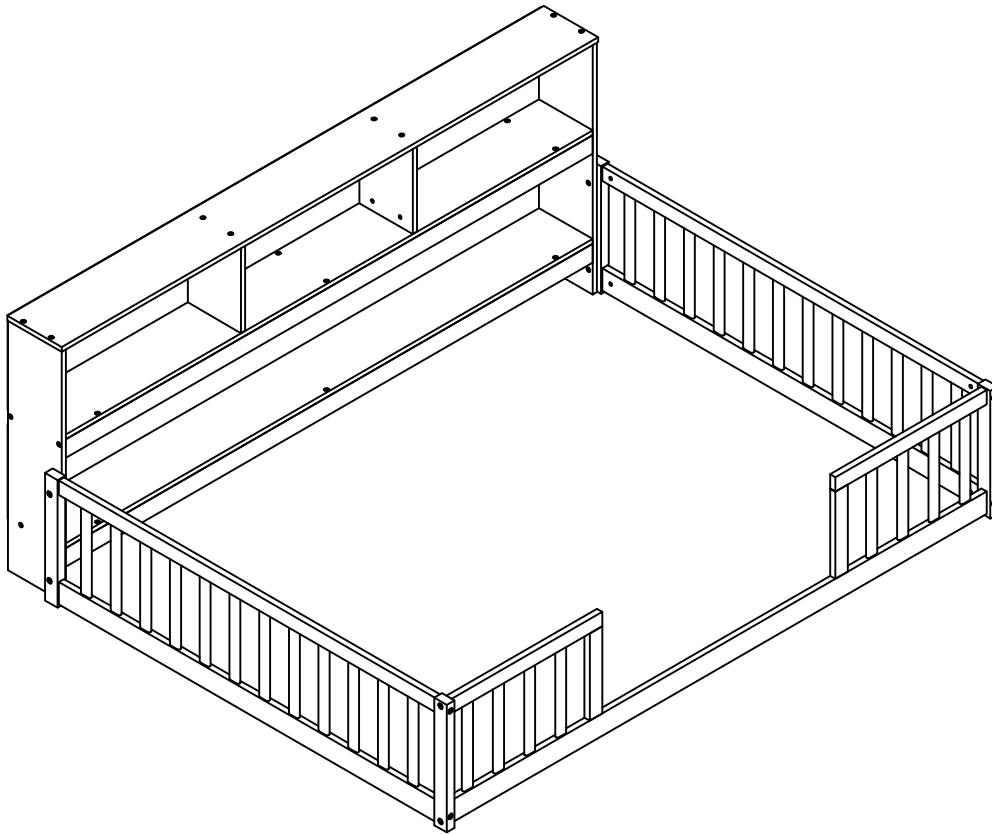

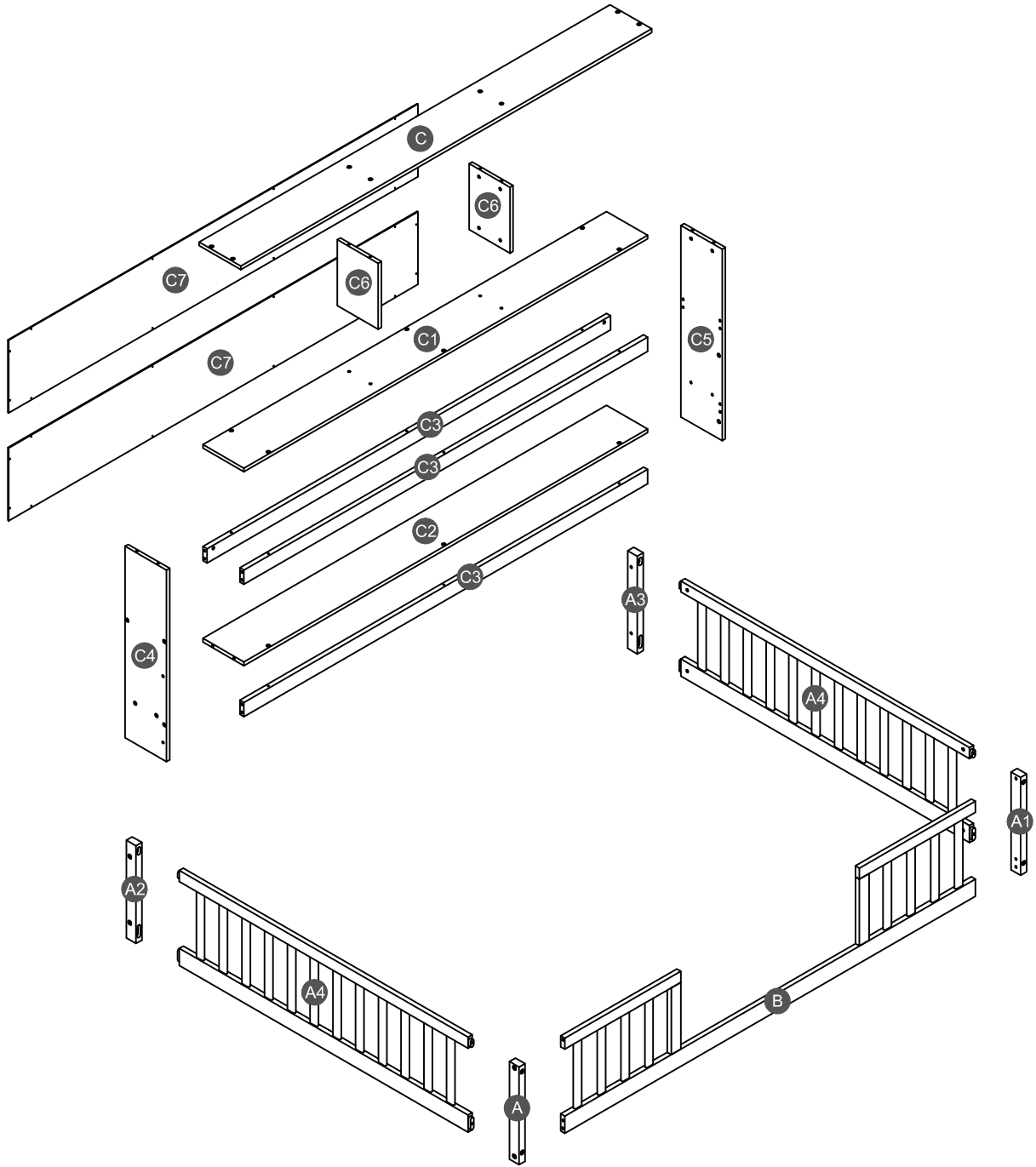



## FULL FLOOR BED WITH SHELVES



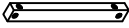
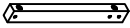
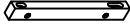
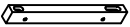
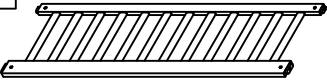

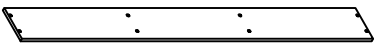
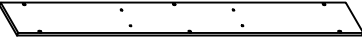
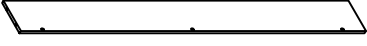

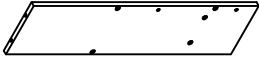
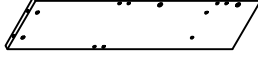

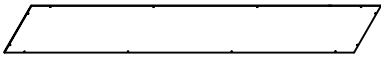
# Detail View

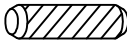
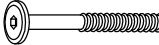
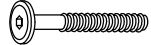

# Part List

<p><b>A</b></p>  <p>Leg (Left Front) - 1pc</p>	<p><b>A1</b></p>  <p>Leg (Right Front) - 1pc</p>	<p><b>A2</b></p>  <p>Leg (Left Back) - 1pc</p>
<p><b>A3</b></p>  <p>Leg (Right Back) - 1pc</p>	<p><b>A4</b></p>  <p>Frame HB/FB - 2pcs</p>	<p><b>B</b></p>  <p>Guard rail (Front) - 1pc</p>
<p><b>C</b></p>  <p>Top panel - 1pc</p>	<p><b>C1</b></p>  <p>Shelf panel - 1pc</p>	<p><b>C2</b></p>  <p>Bottom panel - 1pc</p>
<p><b>C3</b></p>  <p>Horizontal bar - 3pcs</p>	<p><b>C4</b></p>  <p>Side panel (Left) - 1pc</p>	<p><b>C5</b></p>  <p>Side panel (Right) - 1pc</p>
<p><b>C6</b></p>  <p>Divider panel - 2pcs</p>	<p><b>C7</b></p>  <p>Back panel - 2pcs</p>	

# Hardware List

<b>1</b>  Ø8*30mm Wood dowel (8pcs)	<b>2</b>  (Ø15)1/4"*80mm Hex-Head bolts (12pcs)	<b>3</b>  (Ø12)1/4"*60mm Hex-Head bolts (22pcs)
<b>4</b>  (Ø12)1/4"*40mm Hex-Head bolts (4pcs)	<b>5</b>  1/4"*15 (9.5mm) Horizontal-Hole bolts(34pcs)	<b>6</b>  (Ø12)1/4"*40mm Hex-Head bolts (9pcs)
<b>7</b>  Ø3.5*15mm Wood screws (24pcs)	<b>8</b>  (1/4")4.5*58mm Allen key (1pc)	

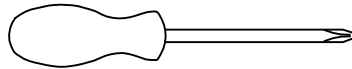

## ASSEMBLY TOOLS REQUIRED ( NOT INCLUDED )

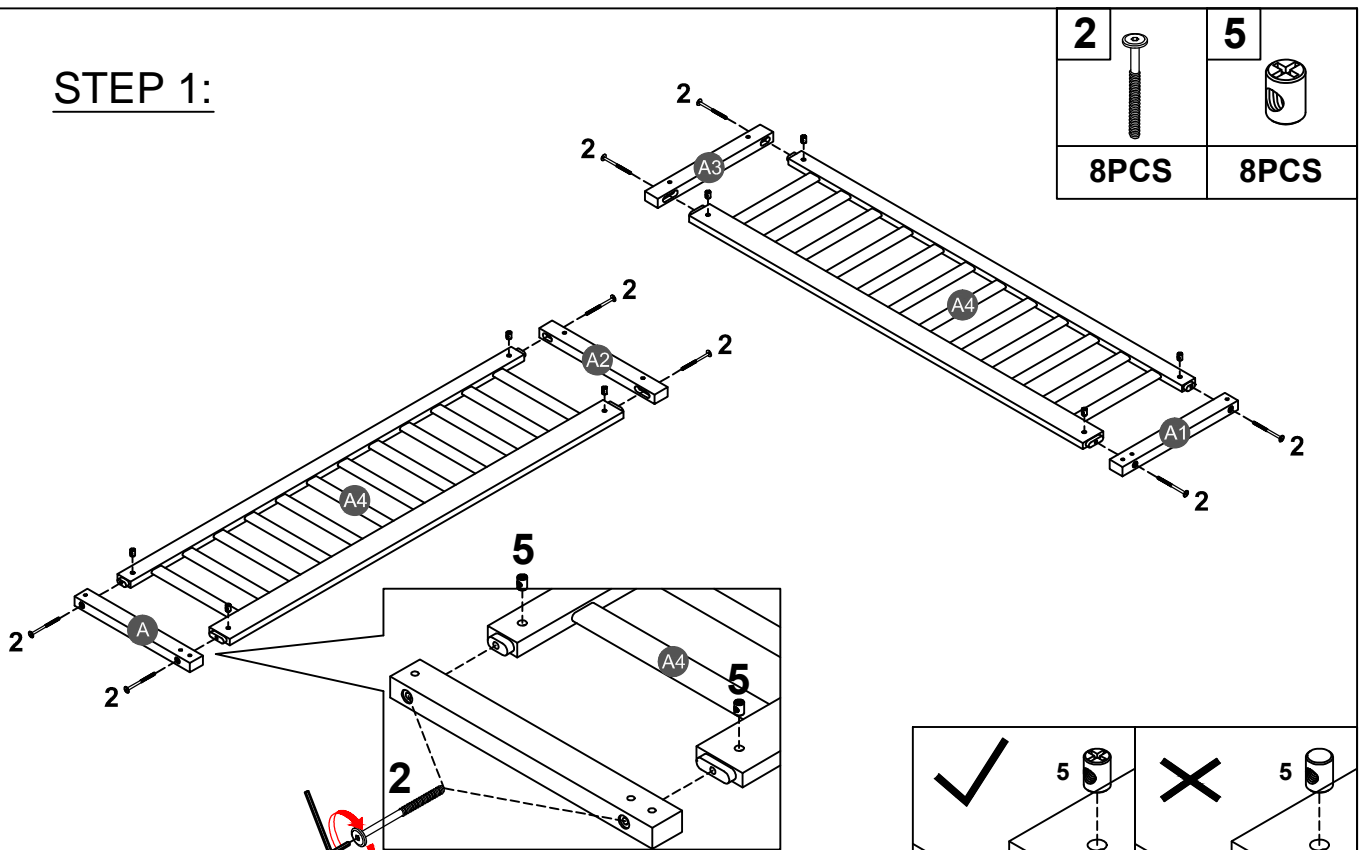

PLEASE BE CAREFUL DO NOT DAMAGE THE HOLE POSITION WHEN YOU USE POWER TOOLS !

**STEP 1:**





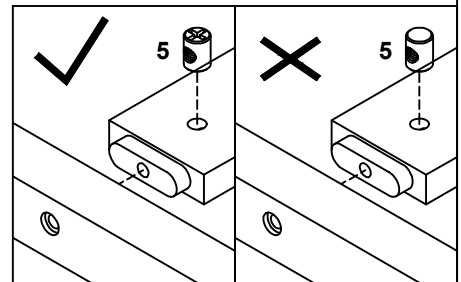

<b>2</b>		<b>5</b>	
<b>8PCS</b>		<b>8PCS</b>	

Note: Part 5 will face up with the "x" mark on it, otherwise it cannot be tightened

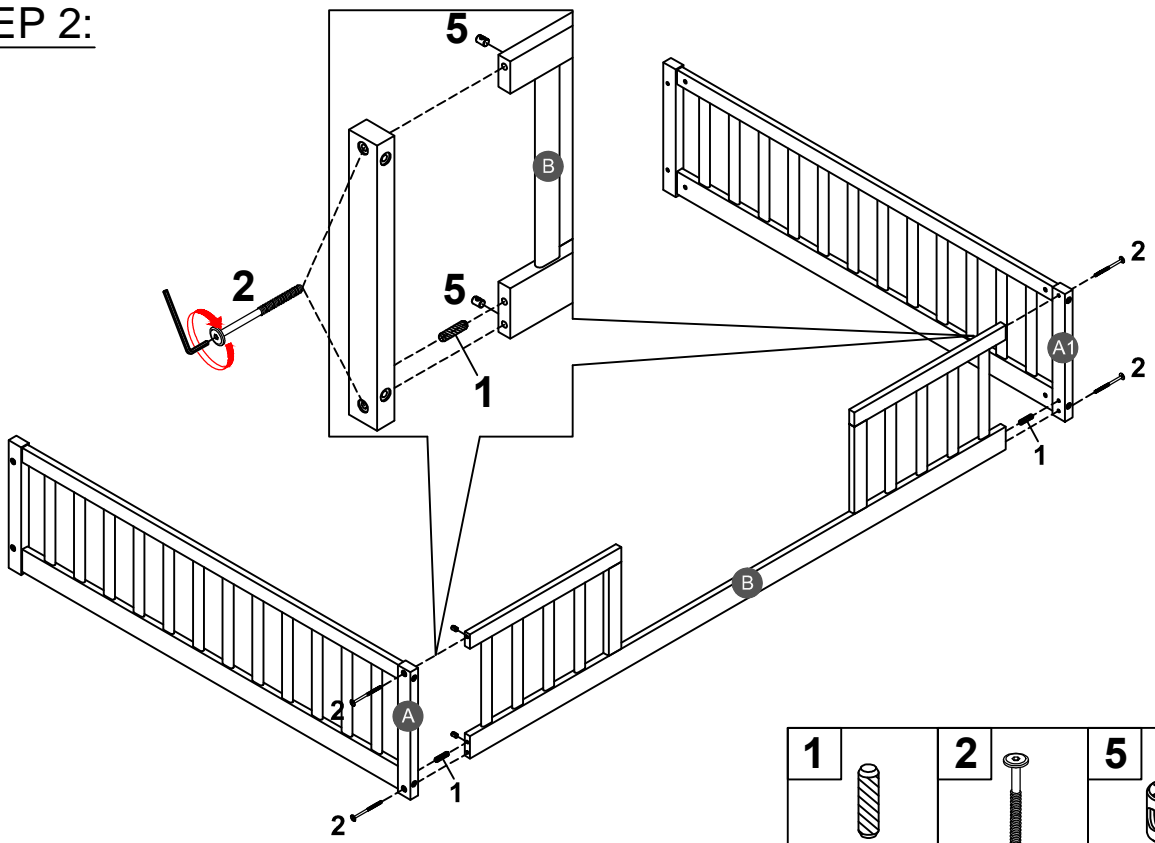



**STEP 2:**



<b>1</b>		<b>2</b>		<b>5</b>	
<b>2PCS</b>		<b>4PCS</b>		<b>4PCS</b>	

**STEP 3:**

<b>1</b>		<b>3</b>		<b>5</b>	
<b>6PCS</b>		<b>10PCS</b>		<b>10PCS</b>	

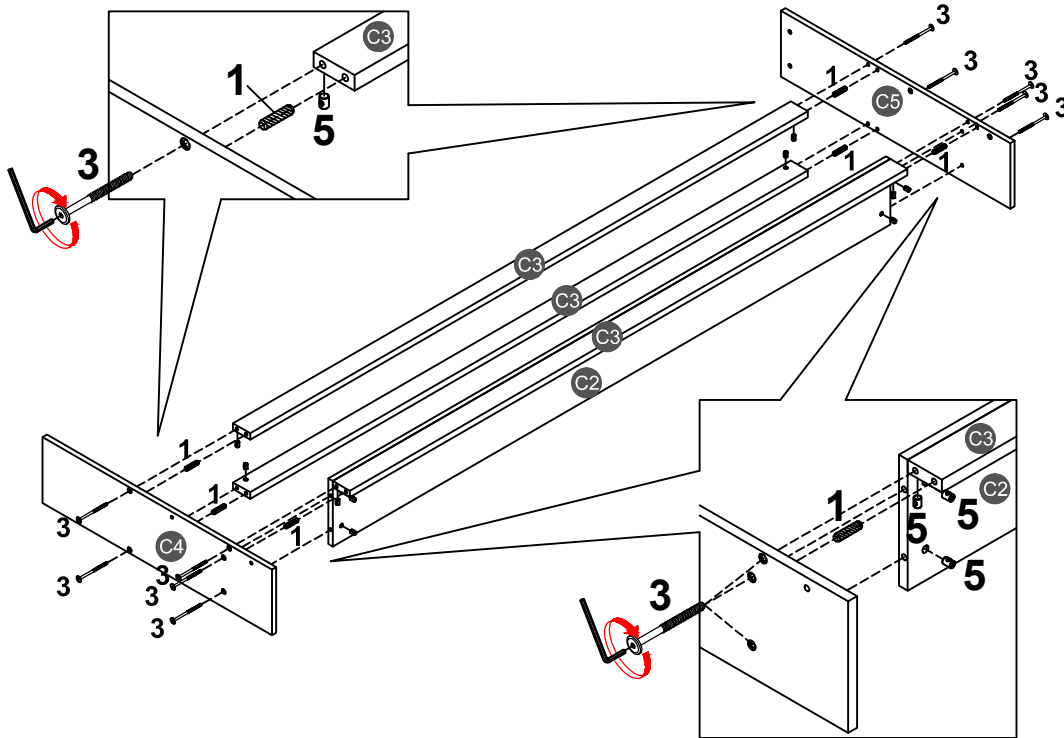

**STEP 4:**

<b>6</b>	
<b>3PCS</b>	

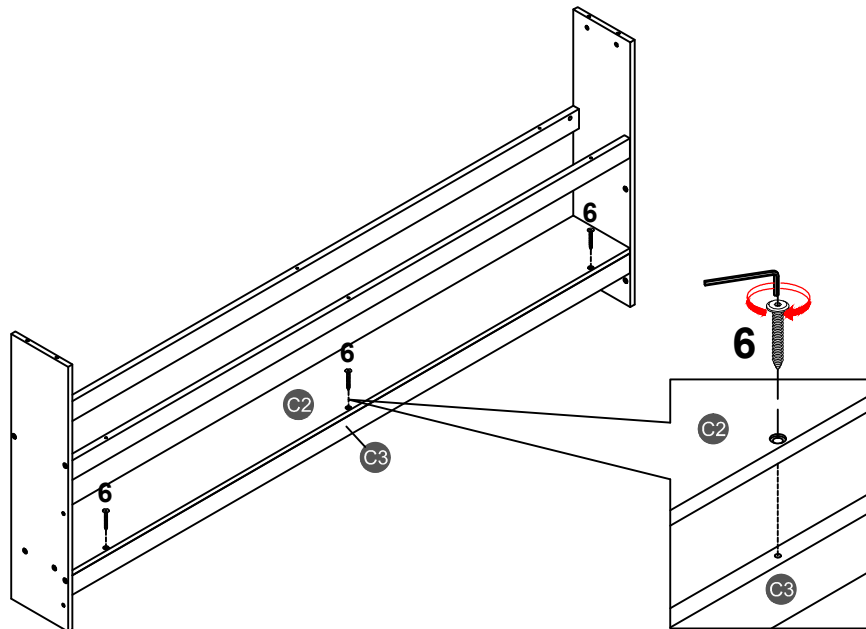

**STEP 5:**

**6**



**6PCS**

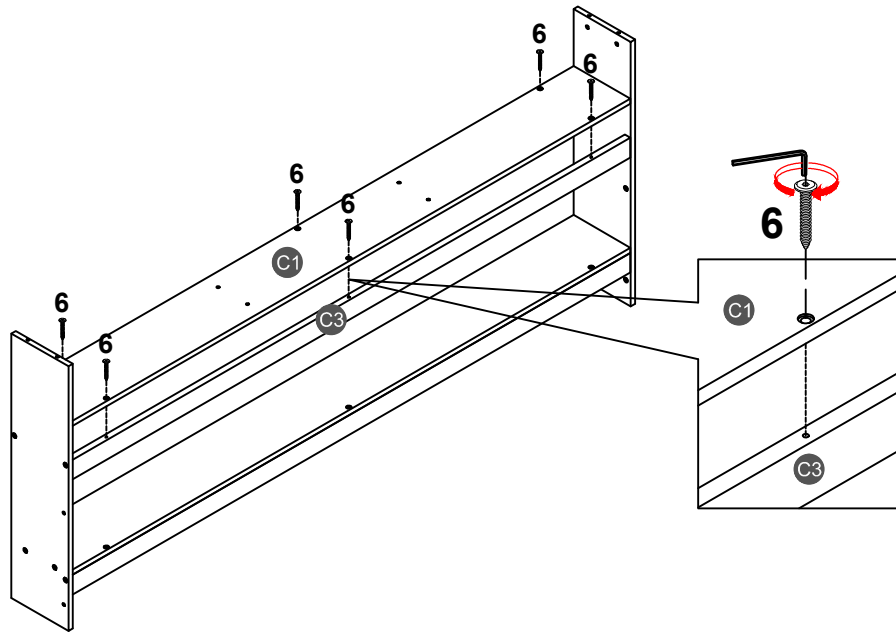

**STEP 6:**

**3**



**4PCS**

**5**



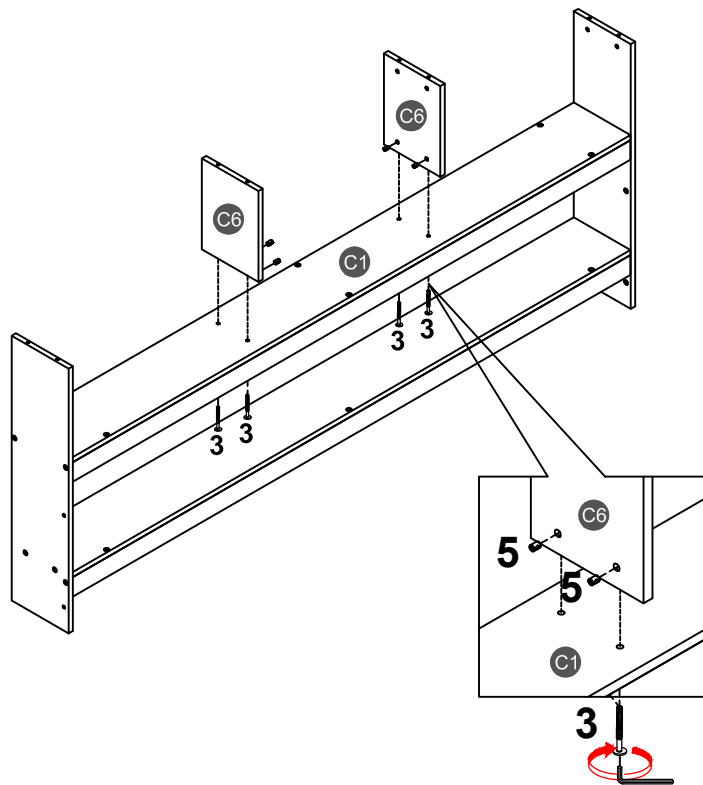

**4PCS**



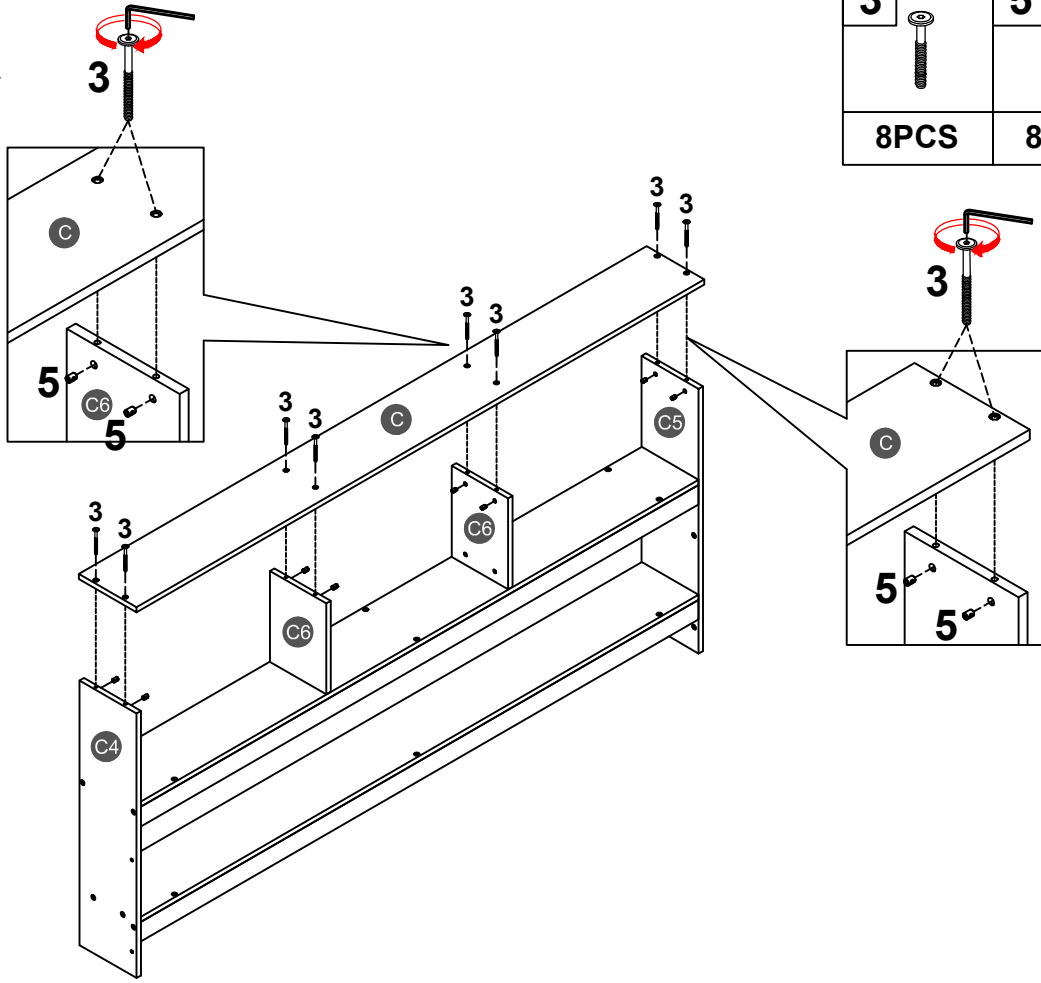

**STEP 7:**

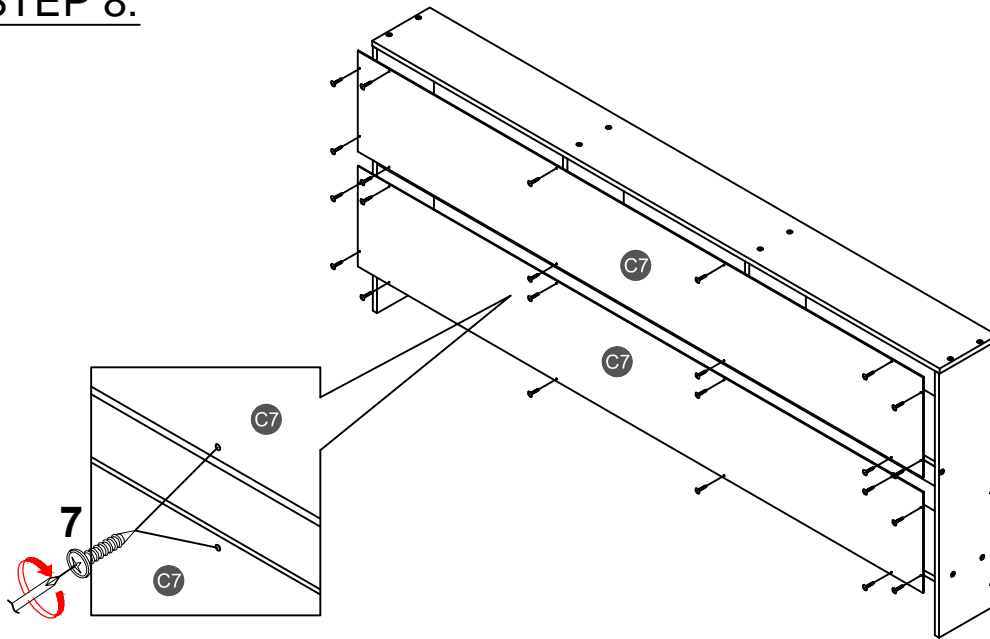

<b>3</b>		<b>5</b>	
<b>8PCS</b>		<b>8PCS</b>	

**STEP 8:**



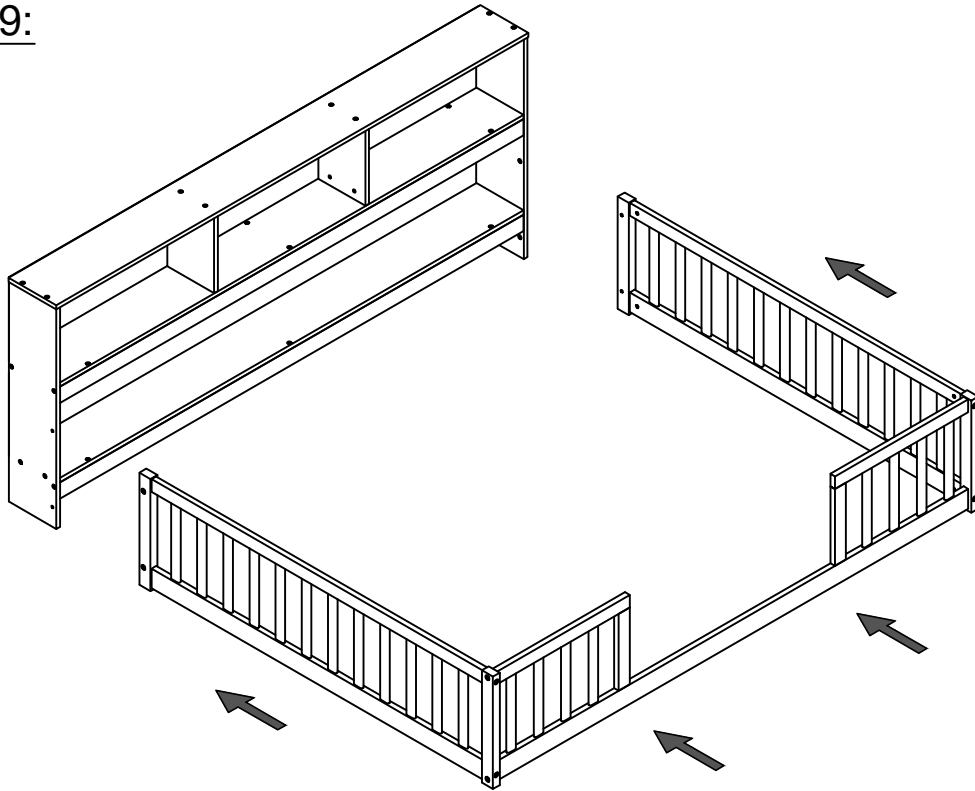

<b>7</b>	
<b>24PCS</b>	

**STEP 9:**

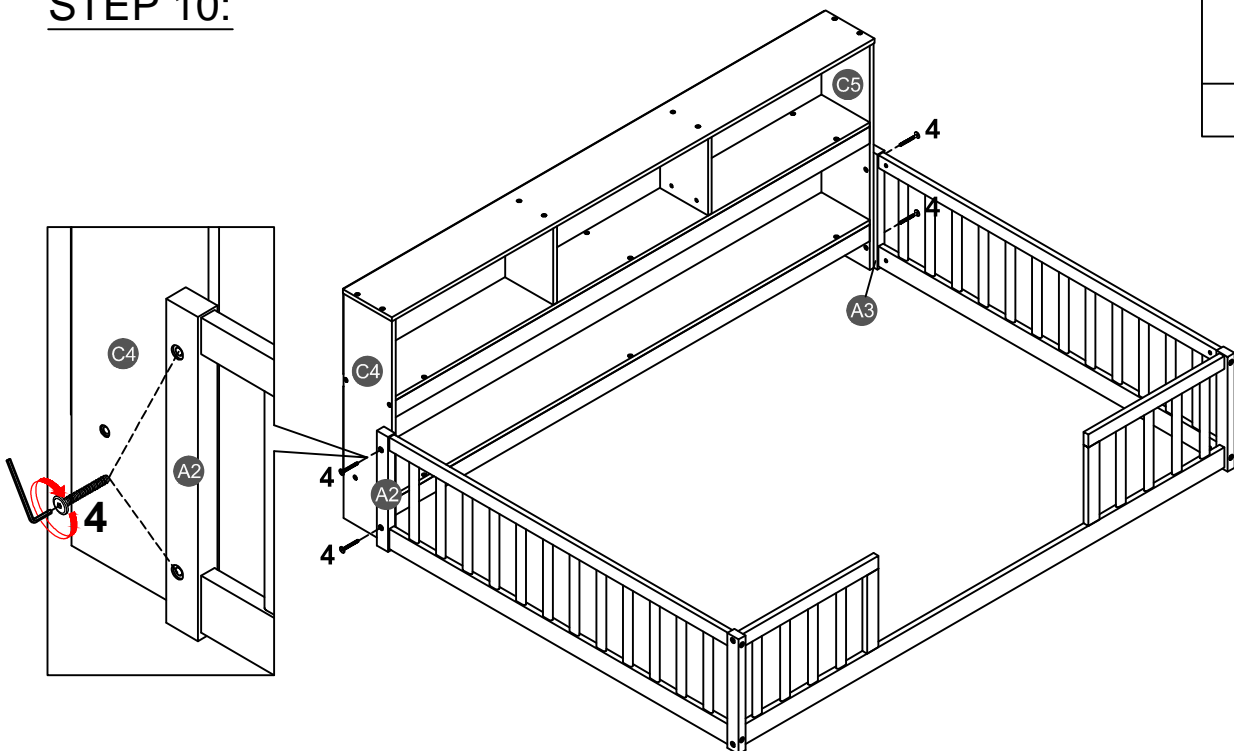

**STEP 10:**



4  
  
4PCS