

Assembly Manual

Modular Sectional Sofa

1336

Please read this manual carefully before any operation and keep it properly for future use.

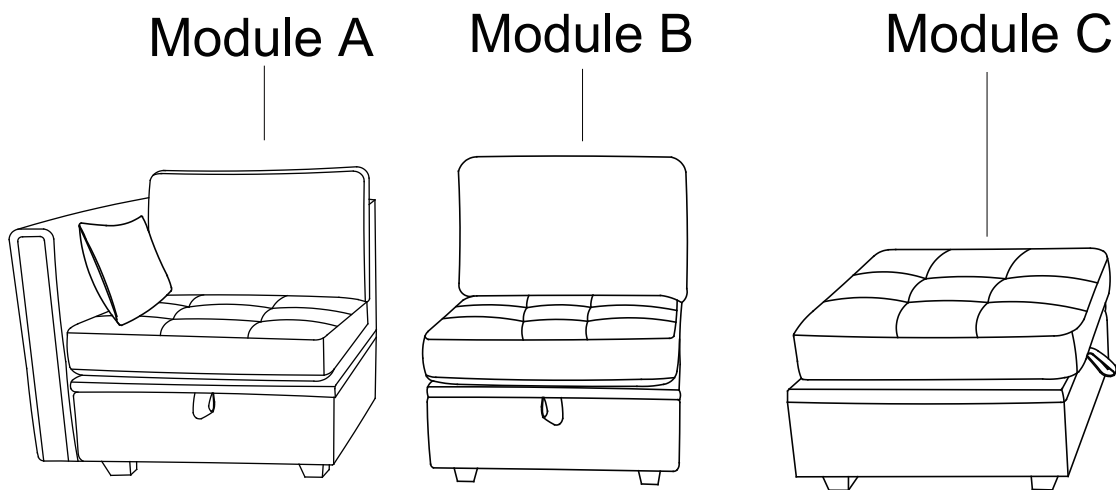

After assembling ABC separately, combine them according to the purchased quantity



Module A installation steps refer to P2-5

Module B installation steps refer to P6-9

Module C installation steps refer to P10-11

Components List-Module A

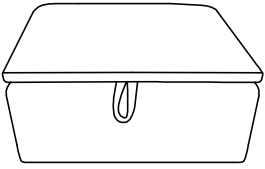
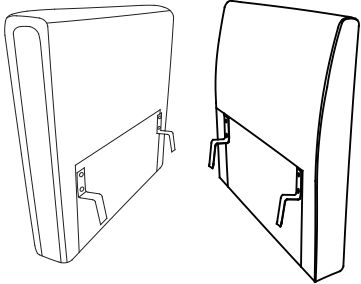
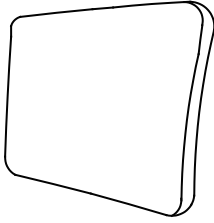
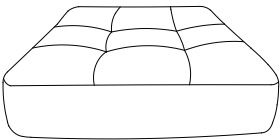
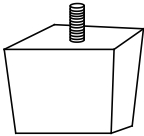
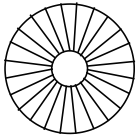
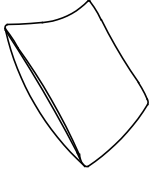
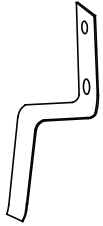
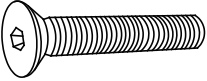
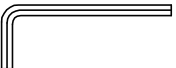
In addition to the normal required quantity,
A has 1 spare part

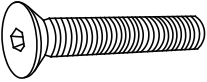
 <p>Sofa ① *1</p>	 <p>Arm/Back ② *2</p>	 <p>Pillow ③ *1</p>	 <p>Cushion ④ *1</p>
 <p>Feet/Foot Pad ⑤ *4</p>	 <p>Plastic Gasket ⑥ *4</p>	 <p>Small pillow ⑦ *1</p>	 <p>Iron sheet ⑧ *4</p>
 <p>M6*30mm ⑨ *8</p>	 <p>Spanner ⑩ *1</p>	 <p>Connector ⑪ *2</p>	 <p>Filler piece ⑫ *2</p>
 <p>M6*18mm ⑬ *4</p>			

Step 1

Please follow the feet of the sofa first.

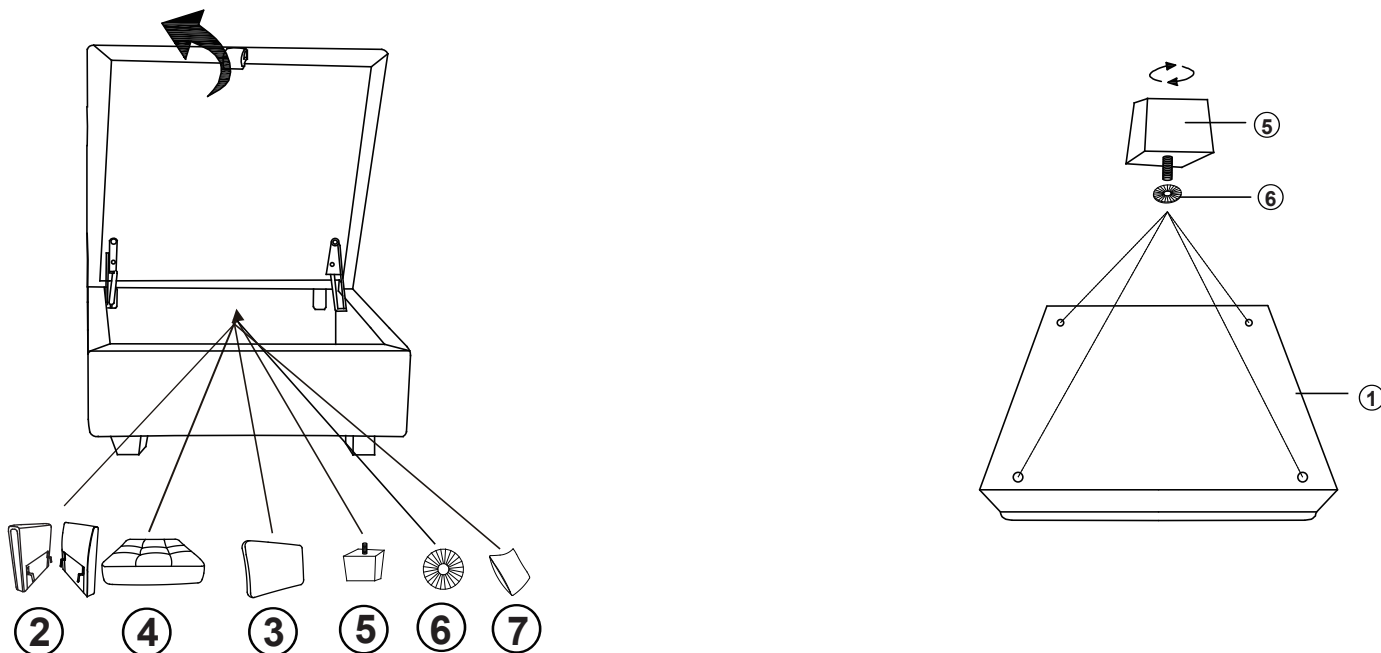

Step 2

Please screw in the armrest/backrest iron first.

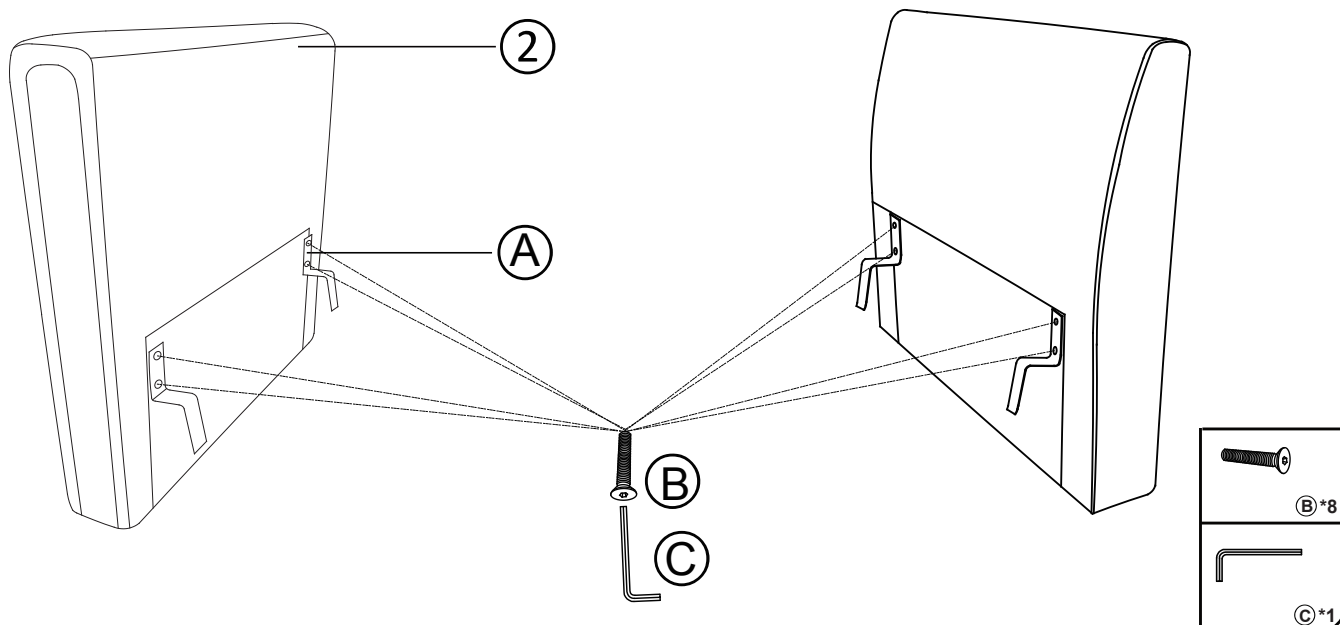

Step 3

Insert the armrest into the seat cushion and wrench the screws to secure the handrail and the seat cushion through the gasket.

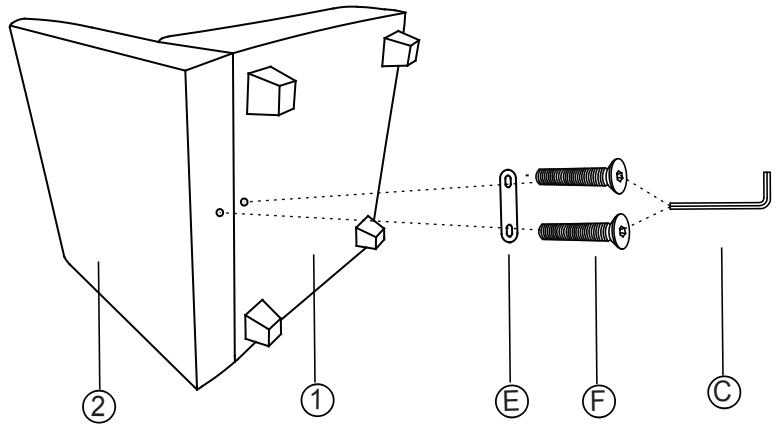
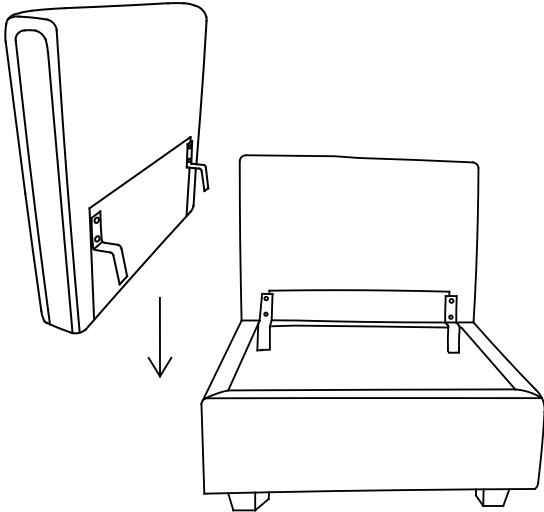

Step 4

Please open the cover of the sofa and insert the backrest into the frame, Attach the other handrail.

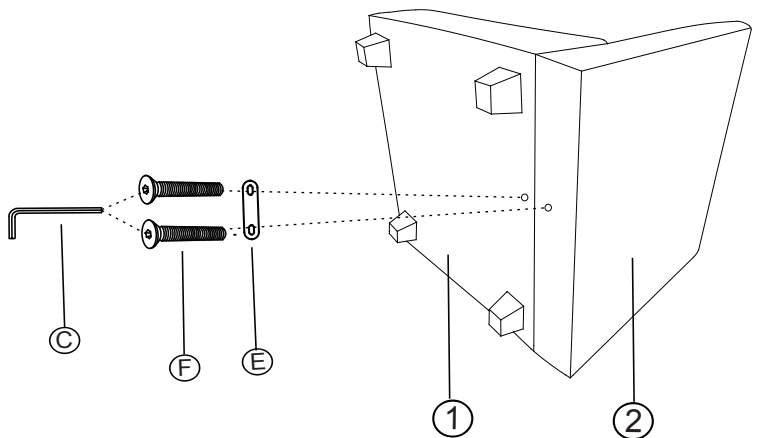
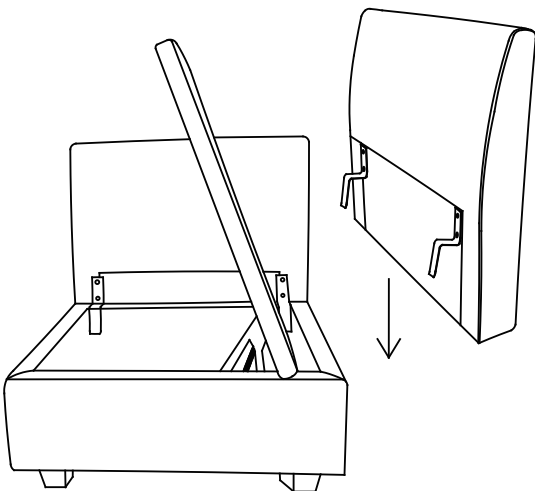

Step 5

Please put the cushion on the sofa.

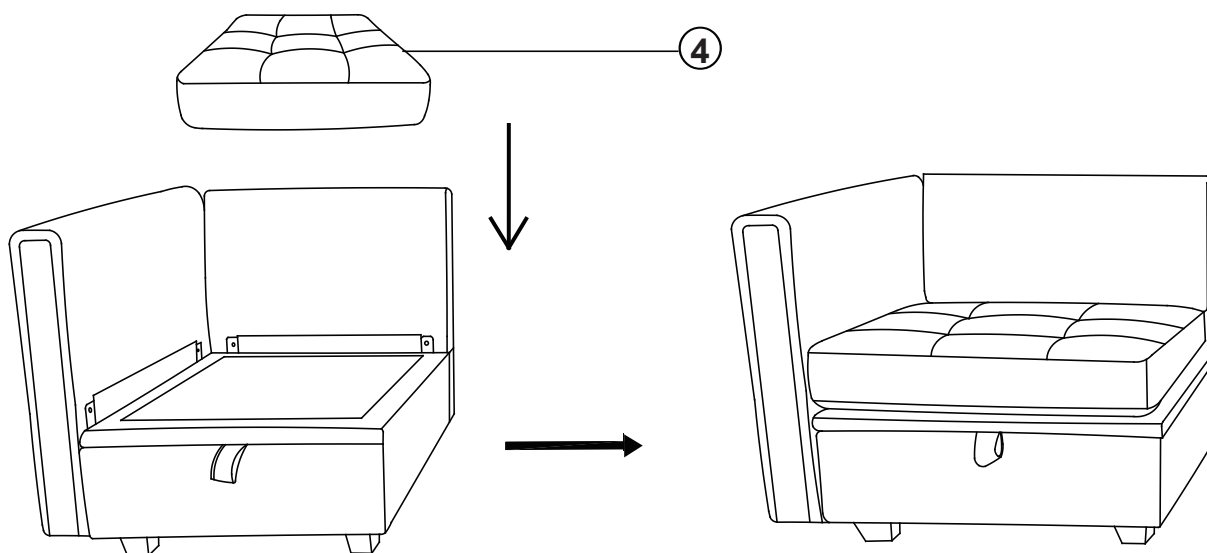





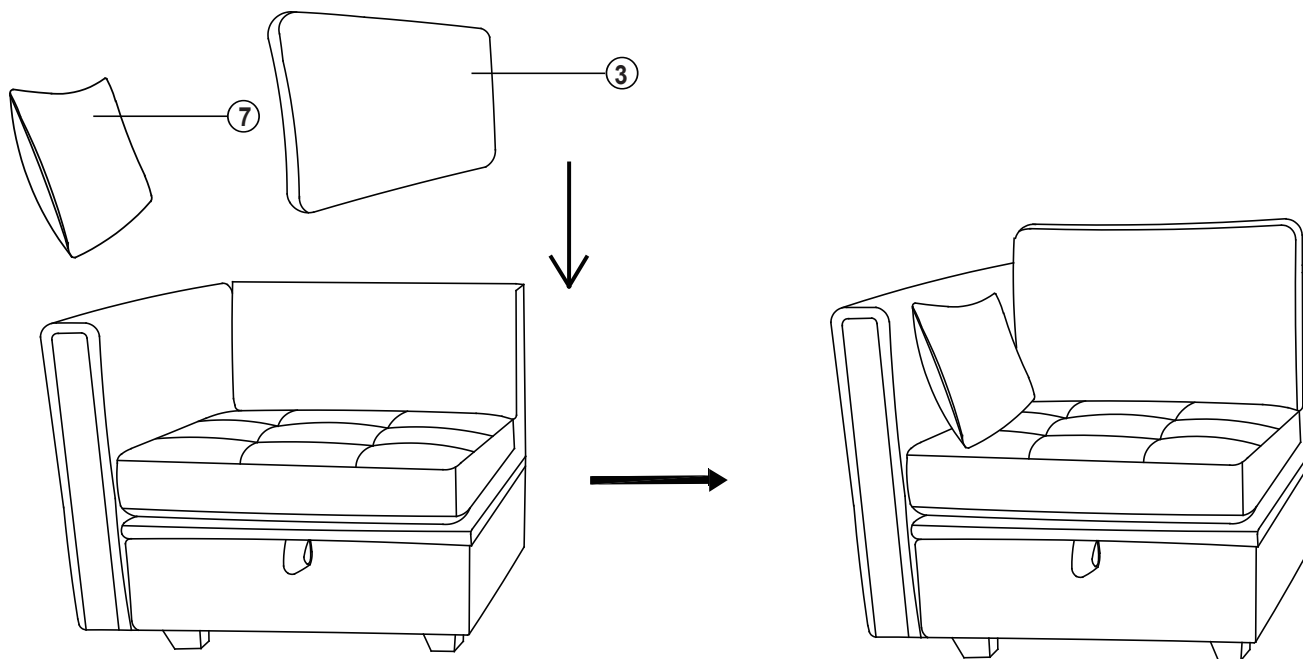

Step 6

Please put the pillow on the cushion.

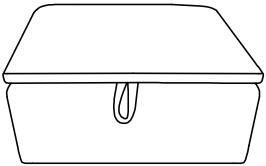
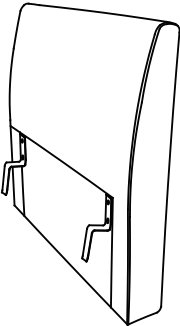
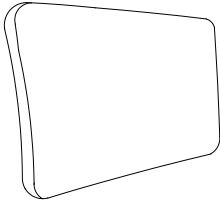
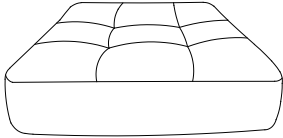
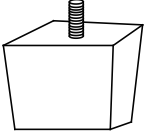
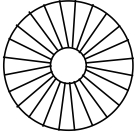

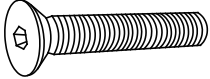
Components List-Module B

In addition to the normal required quantity,
A has 1 spare part

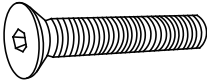
 <p>Sofa ① *1</p>	 <p>Arm/Back ② *1</p>	 <p>Pillow ③ *1</p>	 <p>Cushion ④ *1</p>
 <p>Feet/Foot Pad ⑤ *4</p>	 <p>Plastic Gasket ⑥ *4</p>	 <p>Iron sheet ① *2</p>	 <p>M6*30mm ② *4</p>
 <p>Spanner ③ *1</p>	 <p>Connector ④ *2</p>	 <p>Filler piece ⑤ *1</p>	 <p>M6*18mm ⑥ *2</p>

Step 1

Please follow the feet of the sofa first.

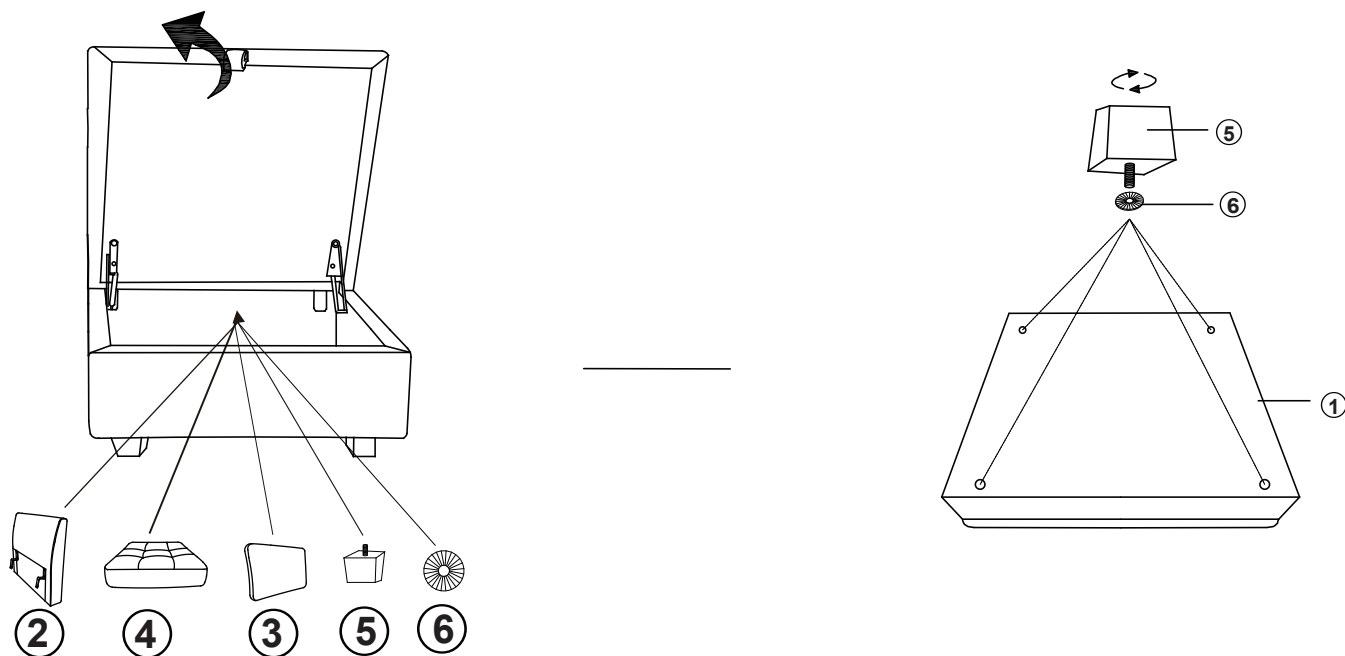

Step 2

Please screw in the armrest/backrest iron first, Twist one foot under the backrest.

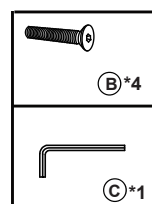
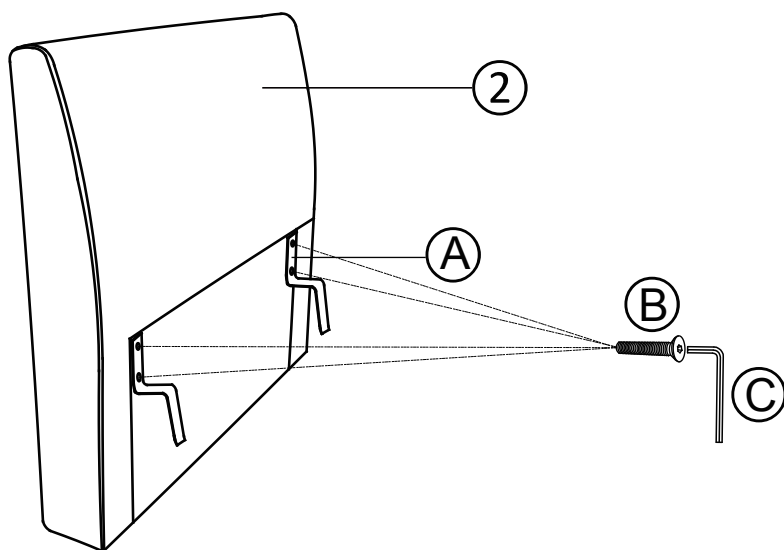

Step 3

Please open the cover of the sofa and insert the backrest into the frame, Attach the other handrail.

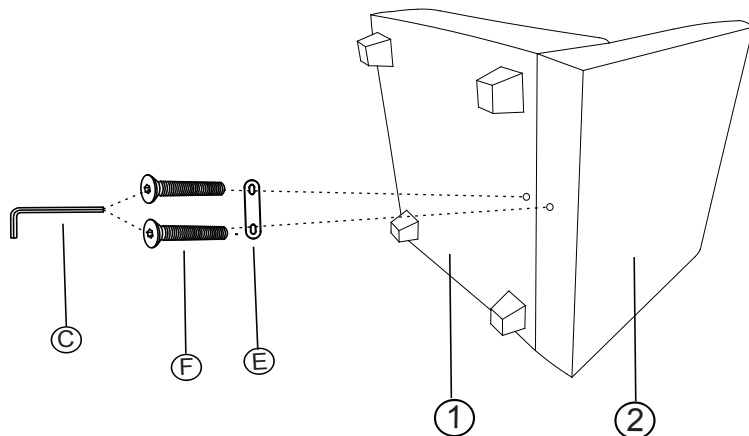
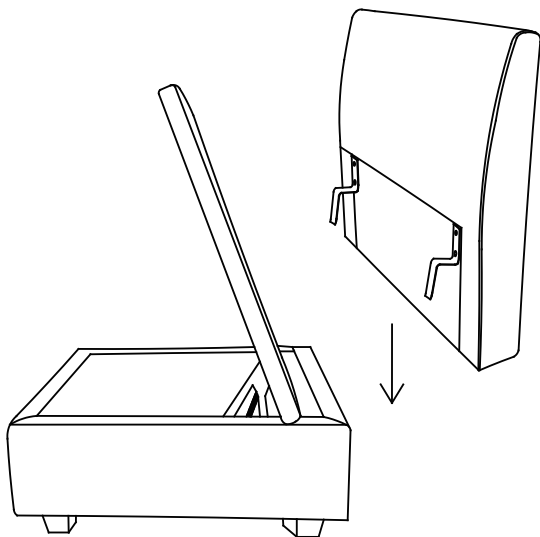

Step 4

Please put the cushion on the sofa.

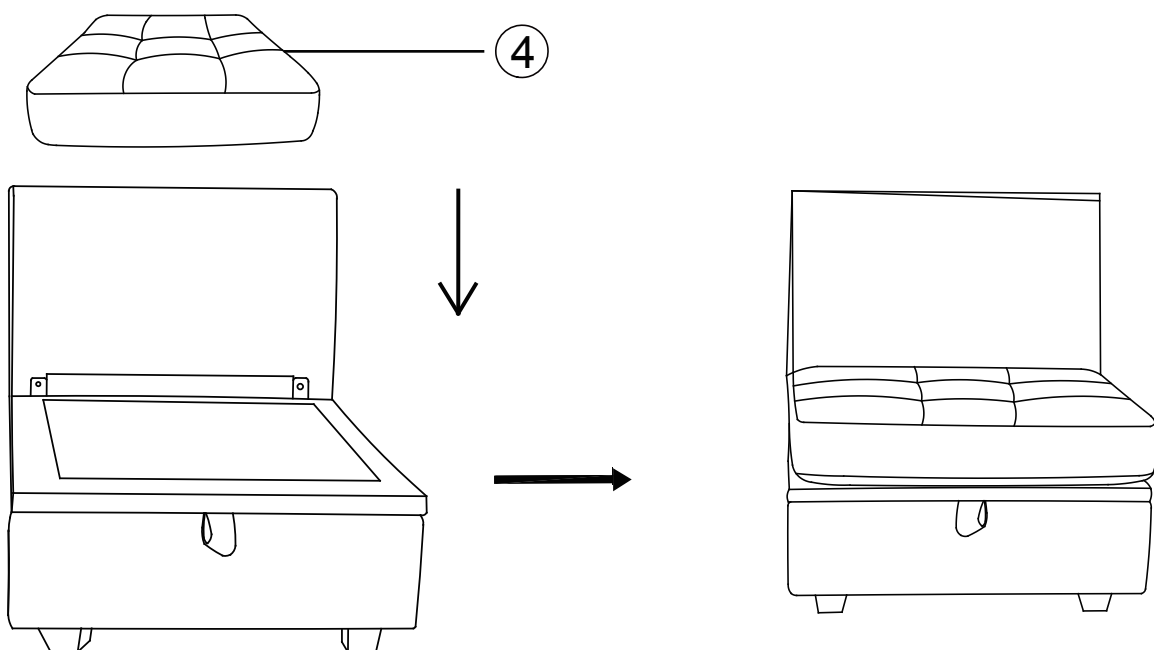

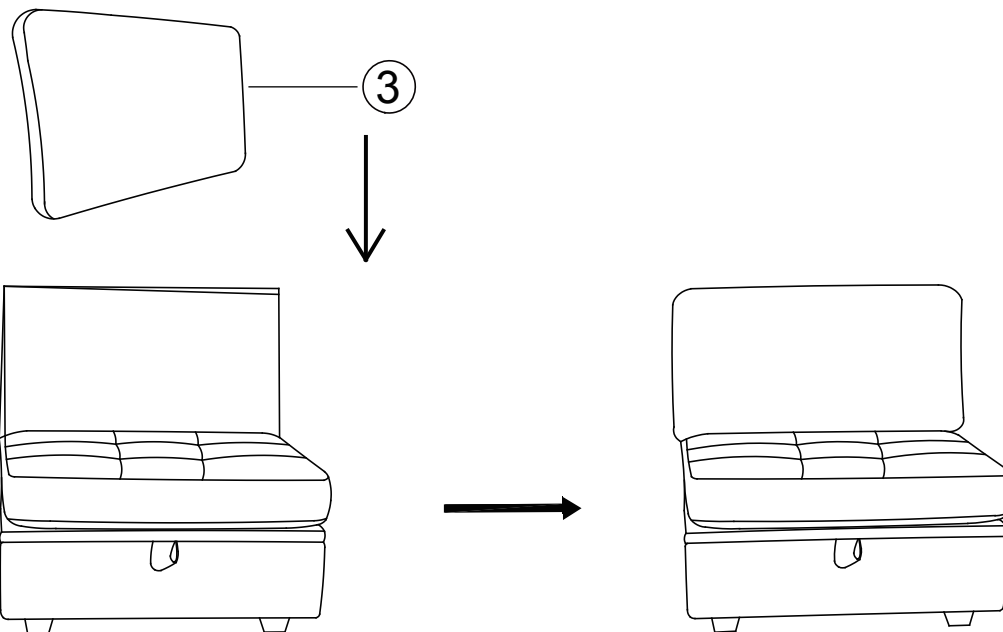

Step 5

Please put the pillow on the cushion.

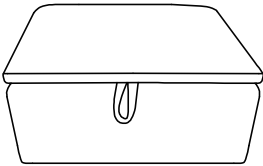
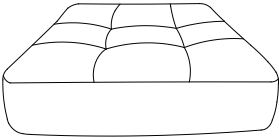
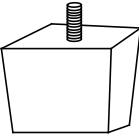
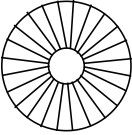

Components List-Module C

 <p>Sofa ① *1</p>	 <p>Cushiion ④ *1</p>	 <p>Feet/Foot Pad ⑤ *4</p>	 <p>Plastic Gasket ⑥ *4</p>
 <p>Connector ①D *2</p>			

Step 1

Please follow the feet of the sofa first.

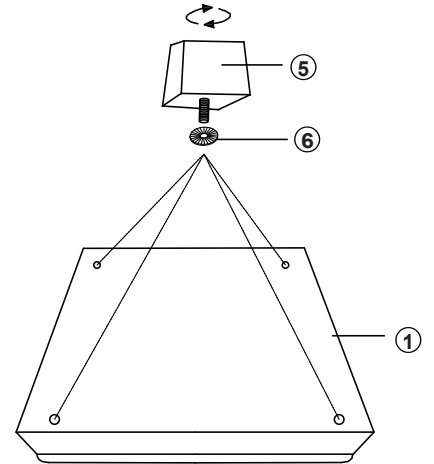
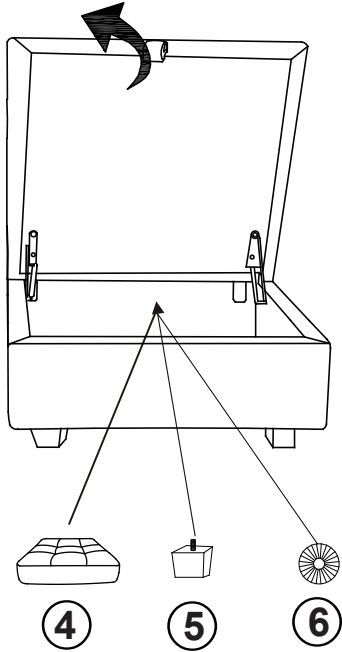

Step 2

Please put the cushion on the sofa.

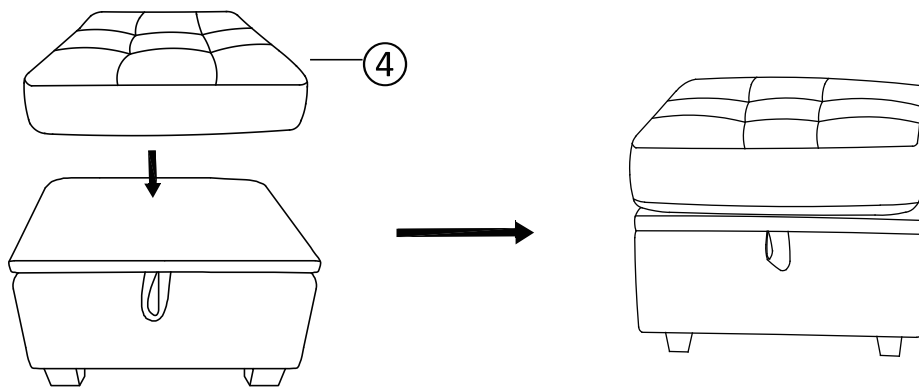

Fix the assembled sofa together with D and then place the seat cushion and backrest on top

-U Shaped installation

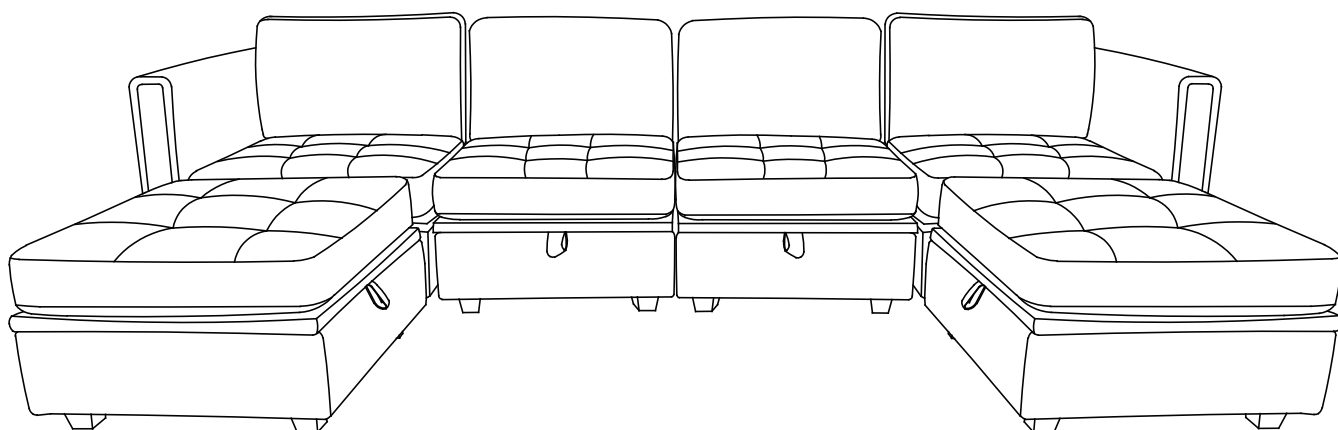
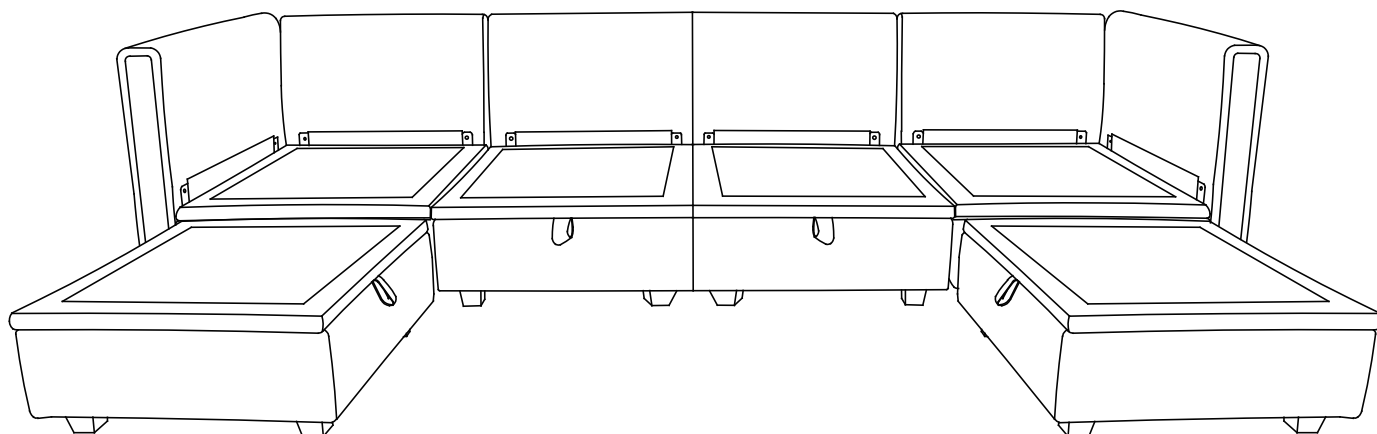
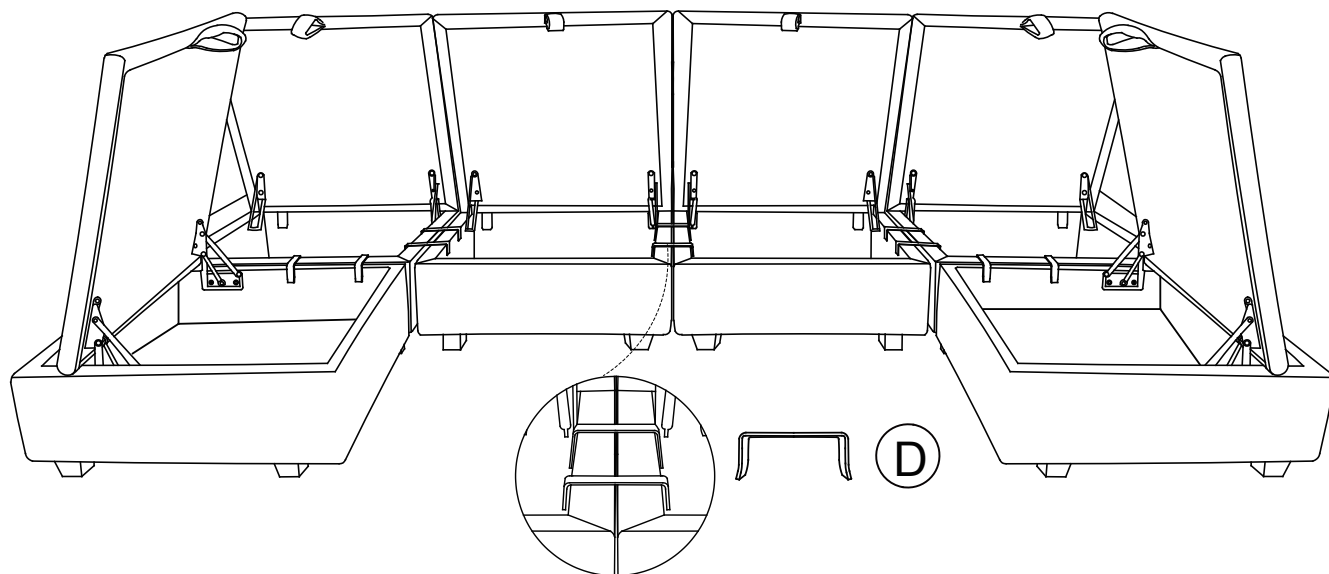

Please install according to the combination method purchased

This sofa of 2 Modules A, 2 Modules B

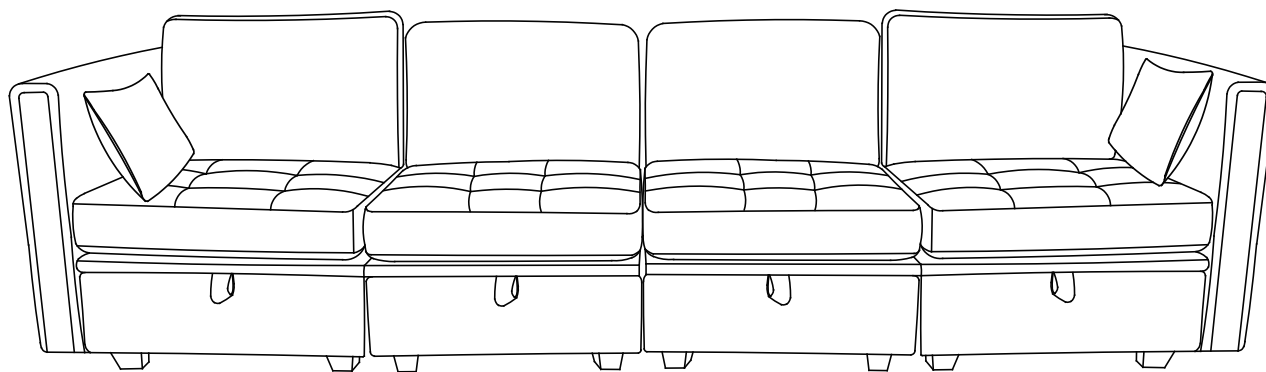

This sofa of 2 Modules A, 2 Modules B, 1 Modules C

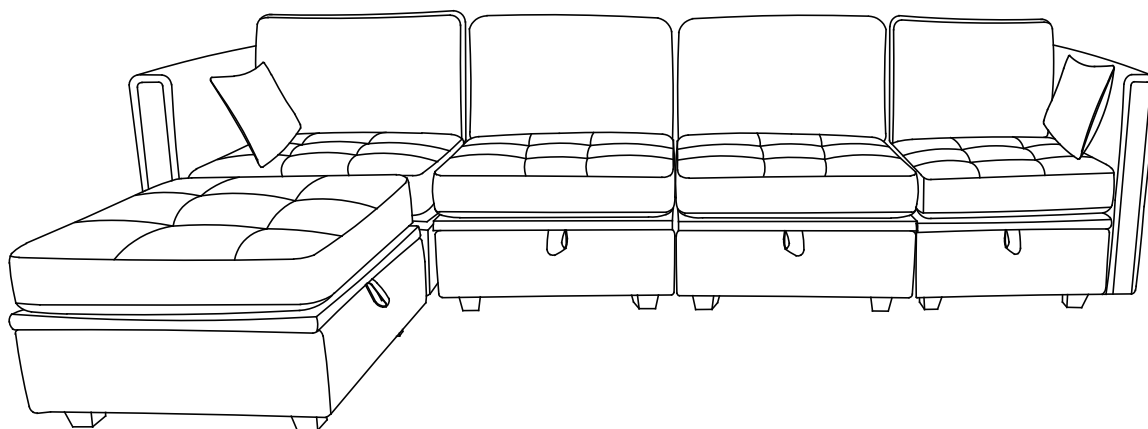

This sofa of 2 Modules A, 2 Modules B, 2 Modules C

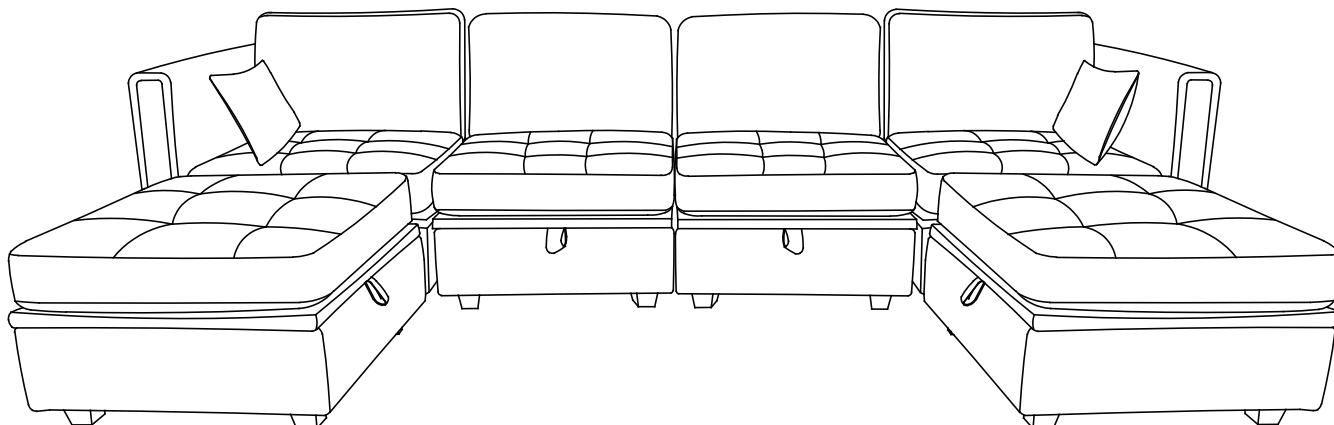

Please install according to the combination method purchased

This sofa of 2 Modules A, 4 Modules B

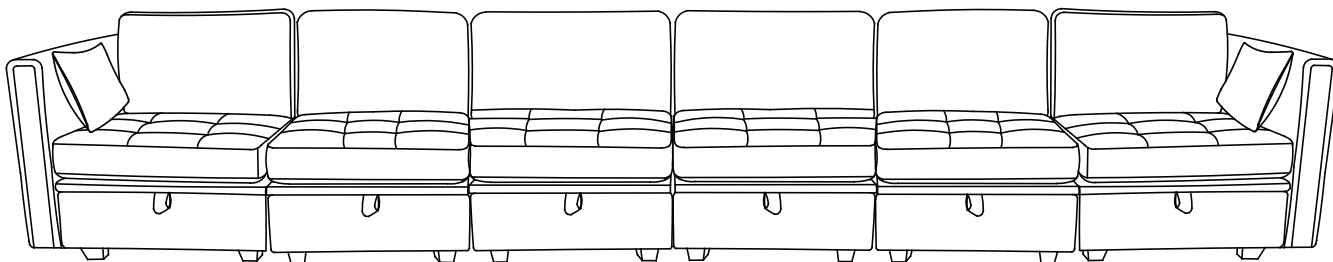

This sofa of 2 Modules A, 2 Modules B, 3 Modules C

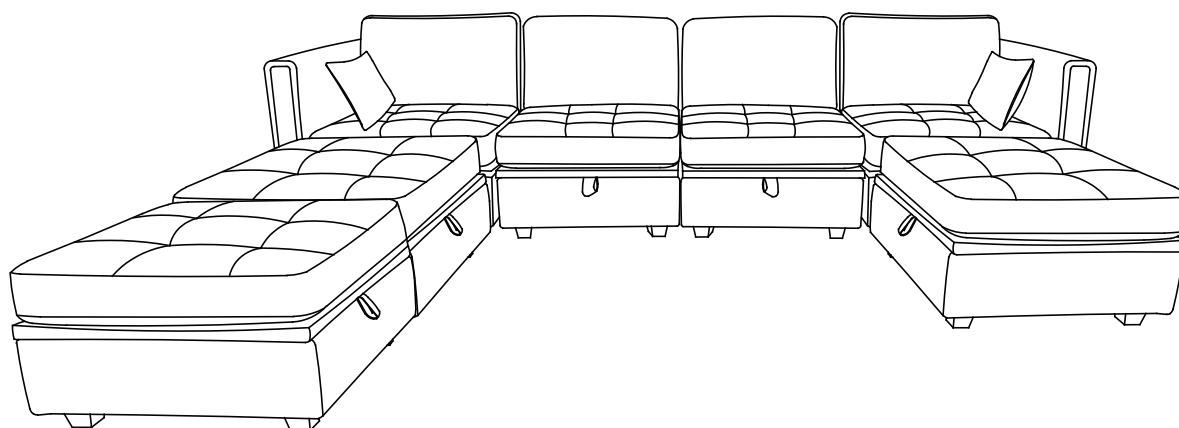

Please install according to the combination method purchased

This sofa of 2 Modules A, 3 Modules B, 1 Modules C

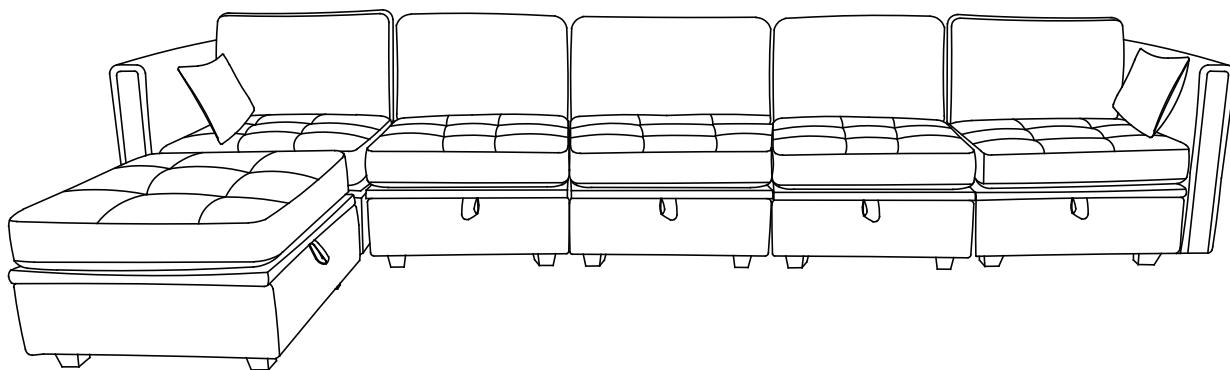

This sofa of 2 Modules A, 3 Modules B, 2 Modules C

