















ASSEMBLY INSTRUCTIONS

HARDWARE LIST

NO.	Sketch	Description	Qty
1		Bolt(M5x4mm)	4 PCS
2		Bolt(1/4"x2-1/8")	8 PCS
3		Bolt(1/4"x5/8")	8 PCS
4		Spring washer(1/4")	12 PCS
5		Washer(1/4")	12 PCS
6		Allen wrench(4mm)	1 PC
7		Allen wrench(2.5mm)	1 PC

PARTS LIST

NO.	Sketch	Description	Qty
A		Seat	1 PC
B		Backrest	1 PC
C		Left metal leg frame	1 PC
D		Right metal leg frame	1 PC
E		Back upper rail	1 PC
F		Front upper rail	1 PC
G		Back Bottom Rail	1 PC
H		Footrest	1 PC

Step 1

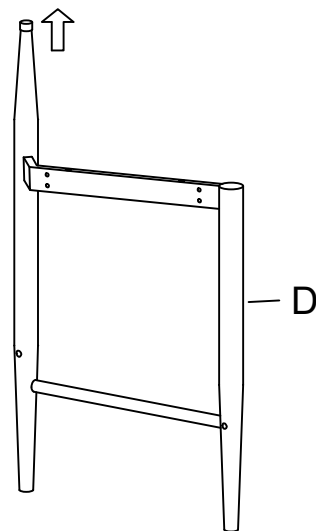
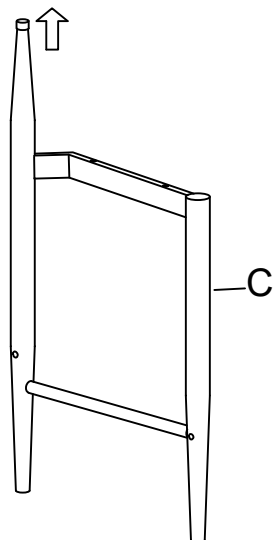

ASSEMBLY INSTRUCTIONS

Step 2

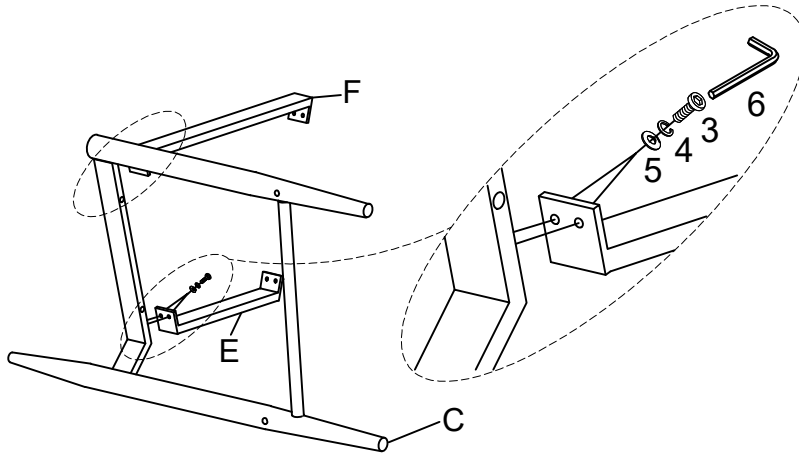

Note: Do not fully tighten the bolts at this step.

Step 3

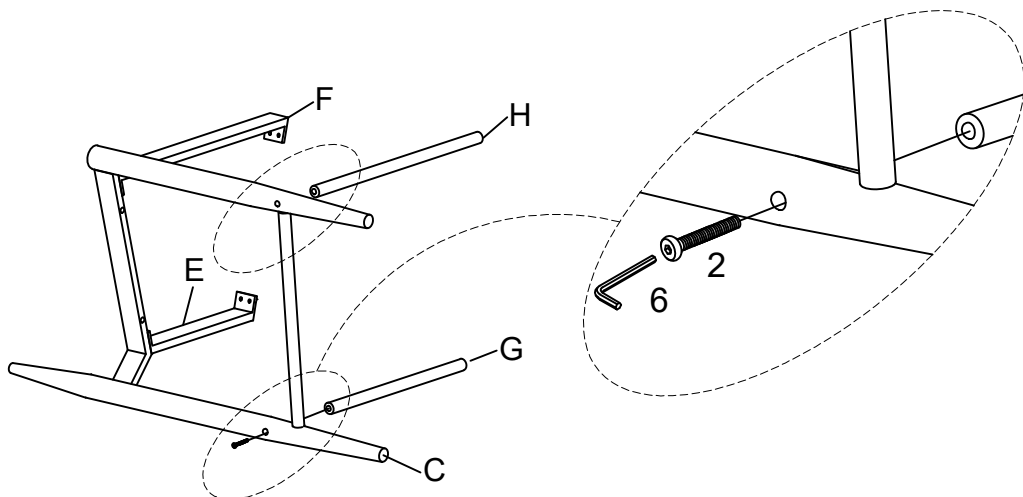

Note: Do not fully tighten the bolts at this step.

ASSEMBLY INSTRUCTIONS

Step 4

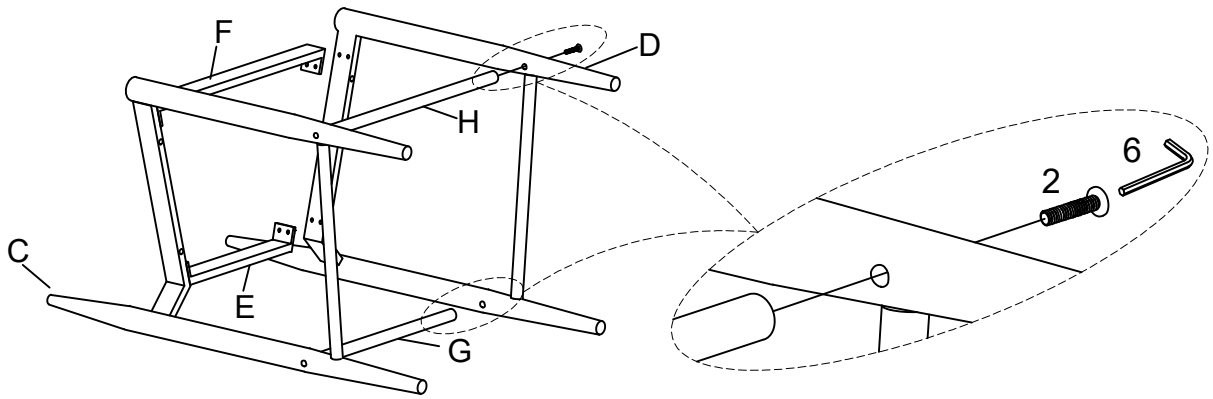

Note: Do not fully tighten the bolts at this step.

Step 5

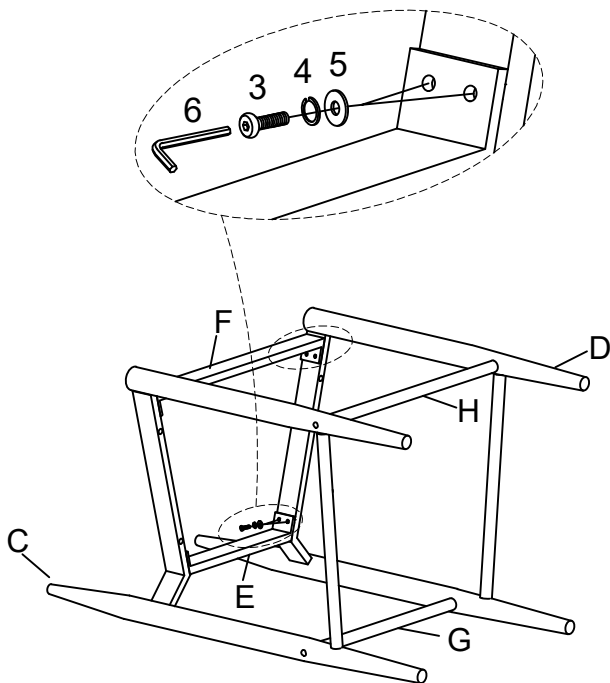

Note: Do not fully tighten the bolts at this step.

Step 6

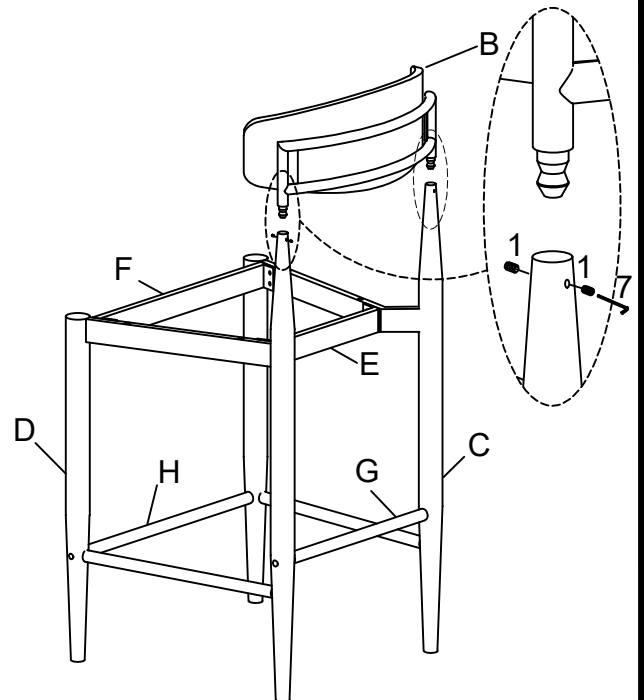

Note: Do not fully tighten the bolts at this step.

ASSEMBLY INSTRUCTIONS

Step 7

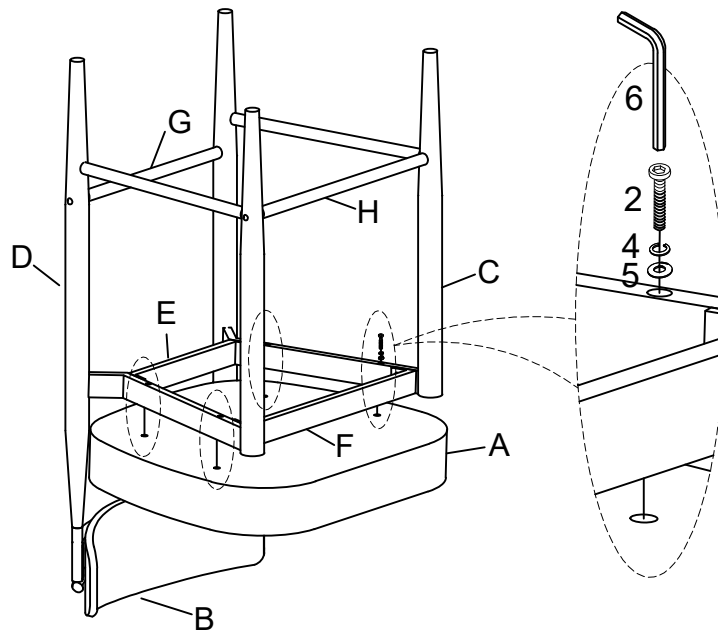

Note: Once the assembly is completed, proceed to tighten all bolts sequentially.

Step 8

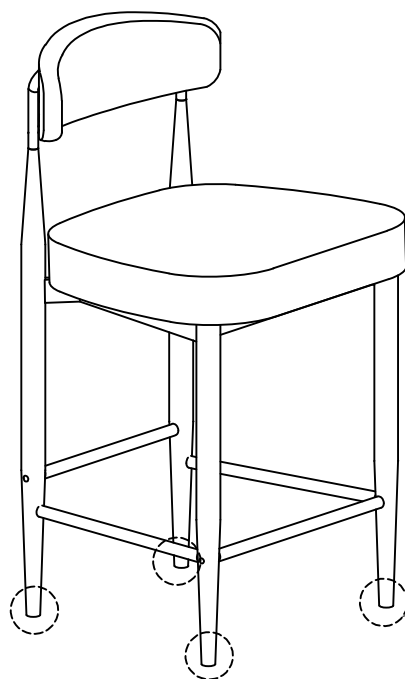

Adjust Pre-installed Levelers height to achieve balance

Step 9

