

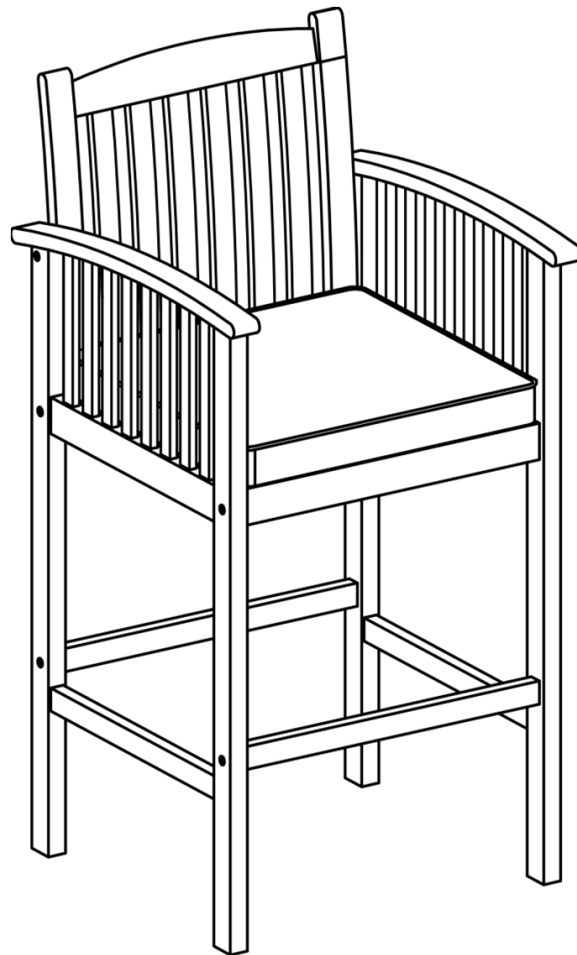



Assembly Instructions

Caution: You must read this before you proceed

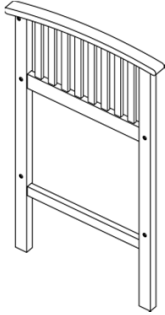
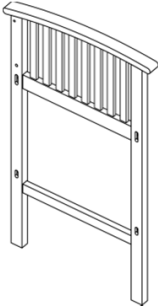

Barstool

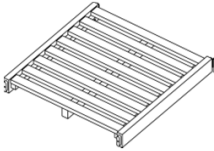

Parts List

Label	Picture	Description	QTY
A		Left Leg Panel	1
B		Right Leg Panel	1
C		Backrest Panel	1
D		Seat Panel	1
E		Leg Support Bar	2
F		Seat Cushion	1

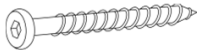
Hardware

Label	Picture	Description	QTY
①		Screw (M6x65mm)	11
②		Allen Key	1

Assembly Preparation

Before Beginning Assembly:

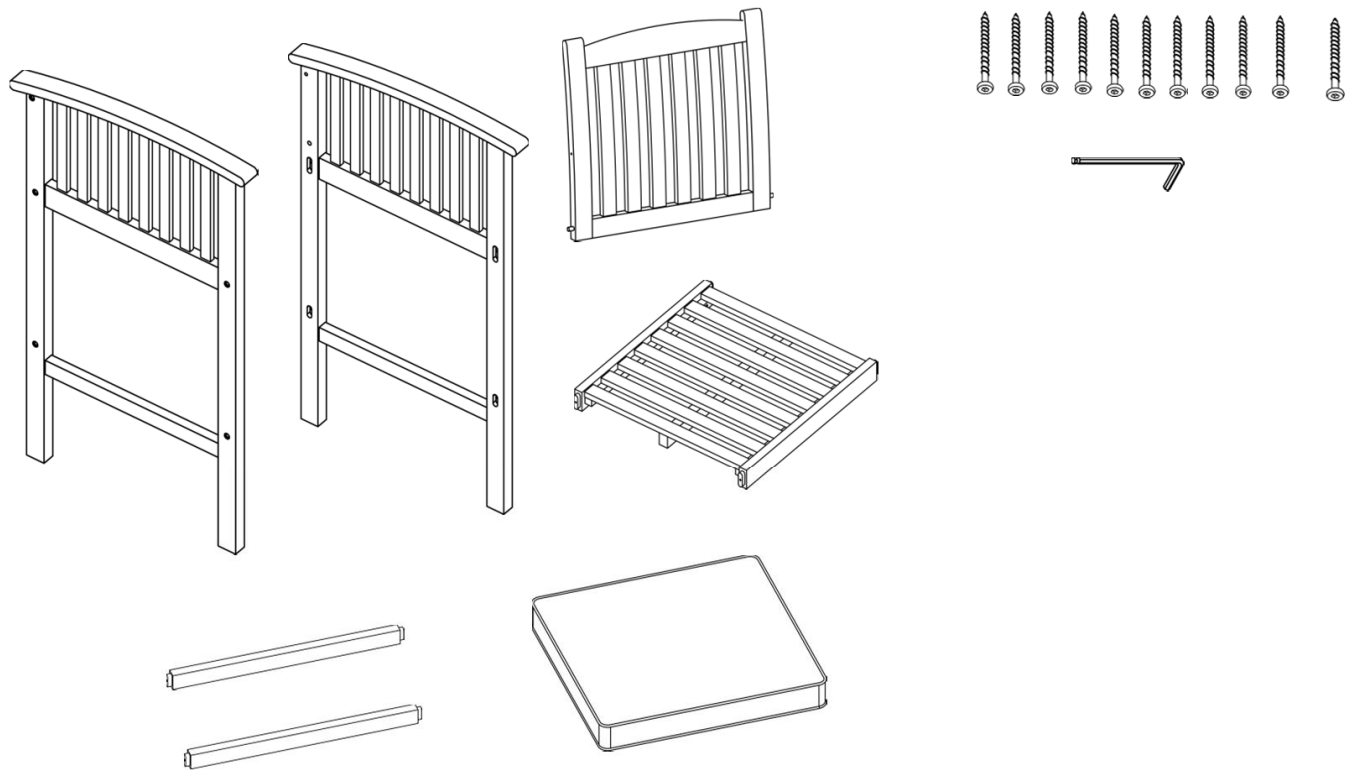

- Read instructions, cover to cover-



- Have 2 adults on hand for assembly-



- Do not assemble on flooring or carpet-



- Assemble on a clean non-marring surface (packing foam)-



- Save all packaging until finished-

Assembly Steps

Overview

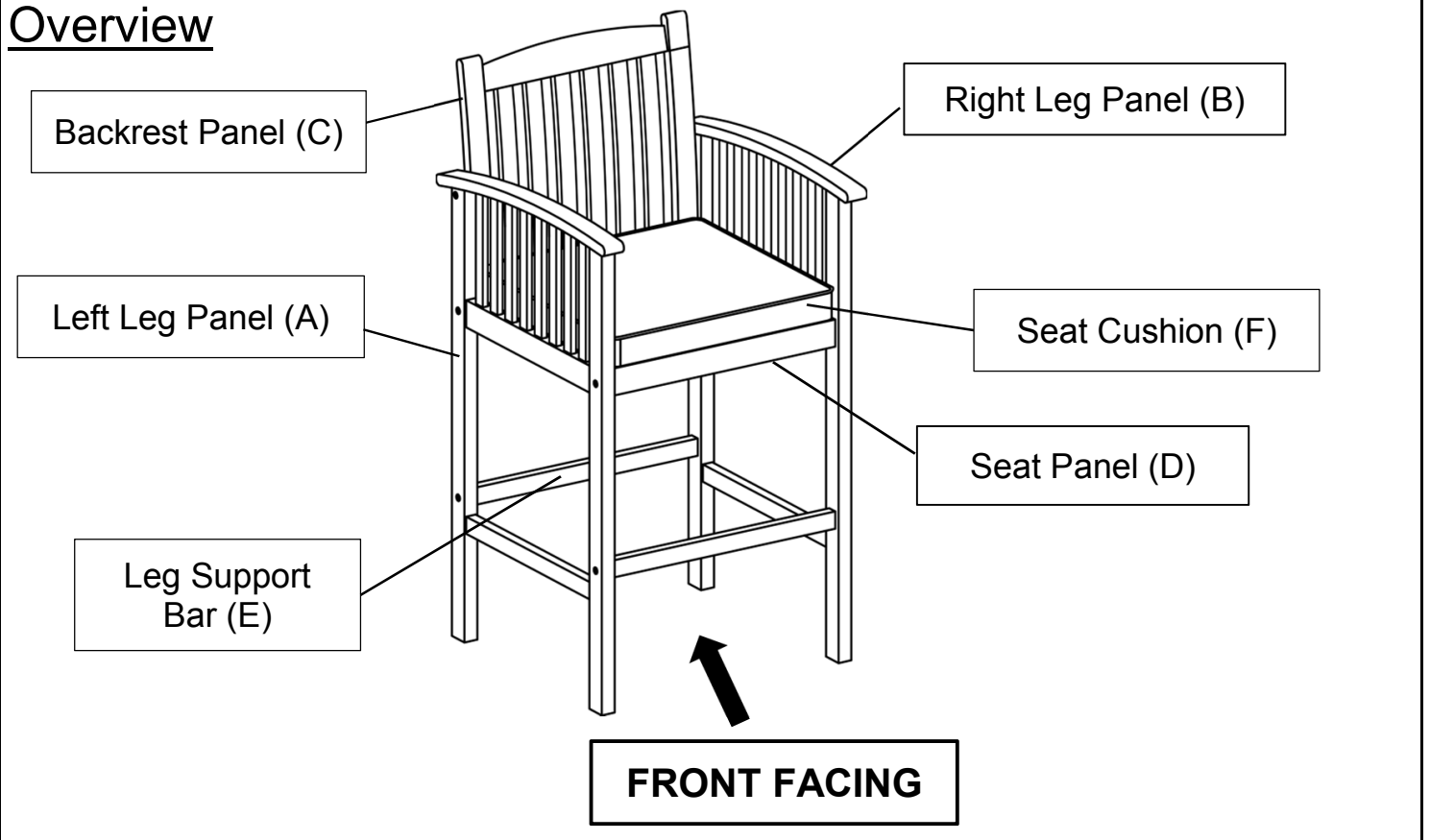

This Barstool has multiple parts and may require up to 30 minutes to assemble. To give you an overview of the Barstool parts, the above picture is to help you put the various parts into perspective. Please read through the instructions below to familiarise yourself with the parts and steps before assembly.

Step 1

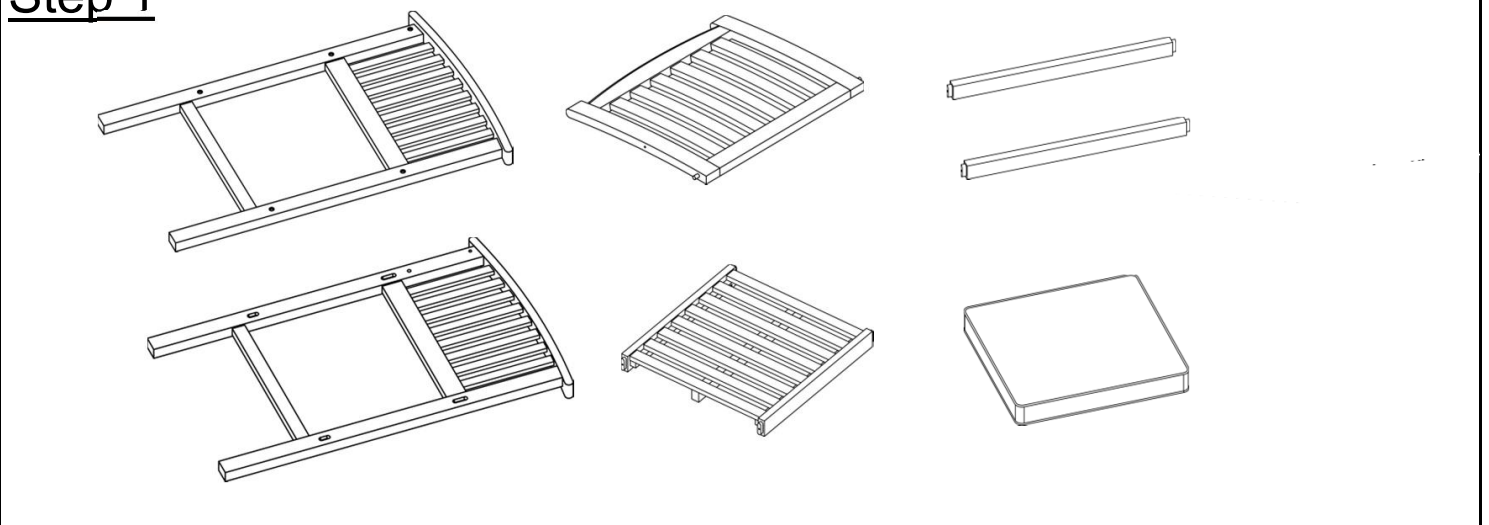

Unpack and place all parts on a clean, non-marring surface.

Step 2

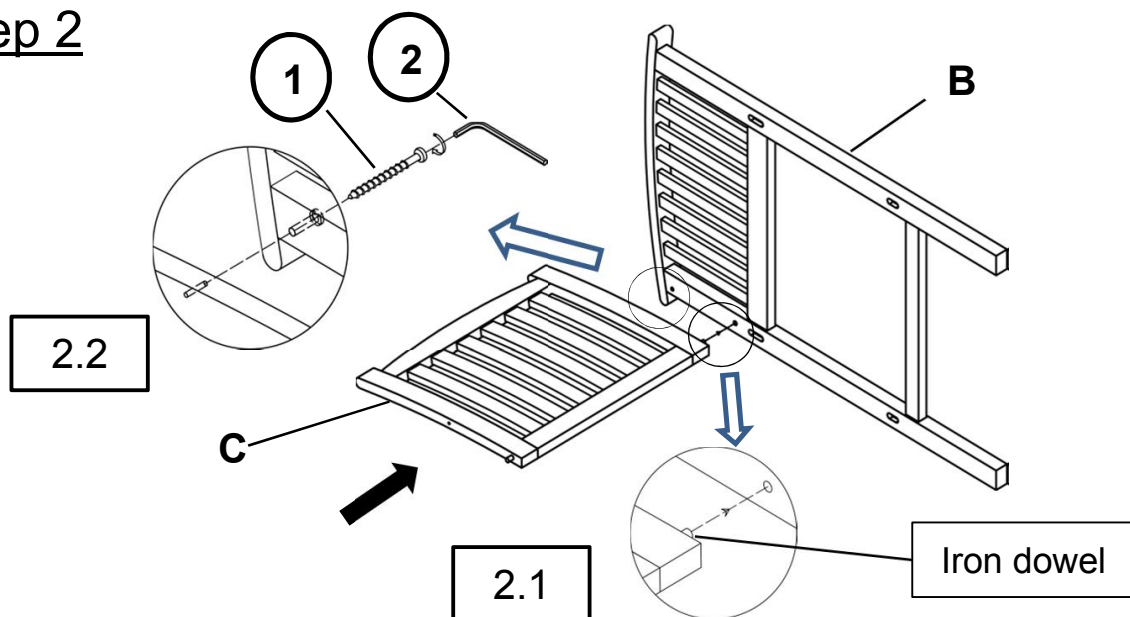

Place the Right Leg Panel(B) at 90 degree as pictured above.

2.1) Insert prefixed iron dowel on Backrest Panel(C) into housing of Right Leg Panel(B).

2.2) Attach Backrest Panel(C) to Right Leg Panel(B) using Screws(①) with Allen Key(②).

Do not fully tighten the Screws.

Step 3

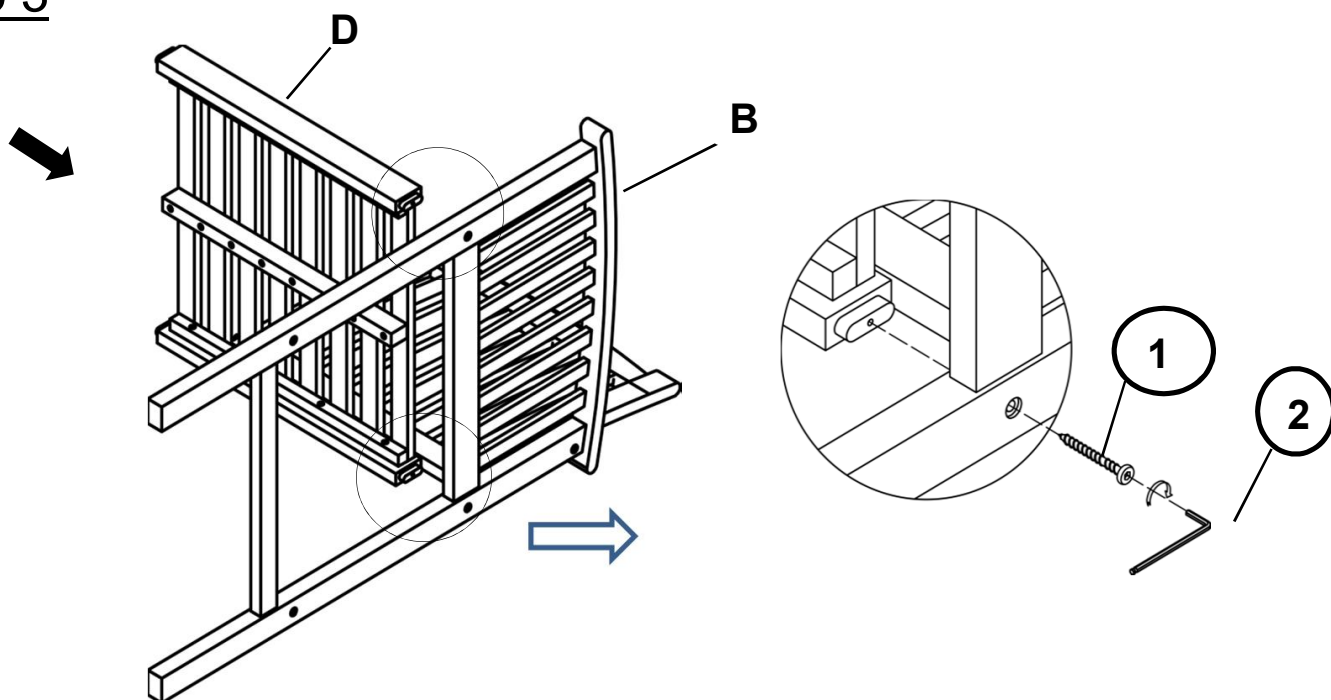

Attach Seat Panel(D) to Right Leg Panel(B) using Screws(①) with Allen Key(②).

Do not fully tighten Screws.

Step 4

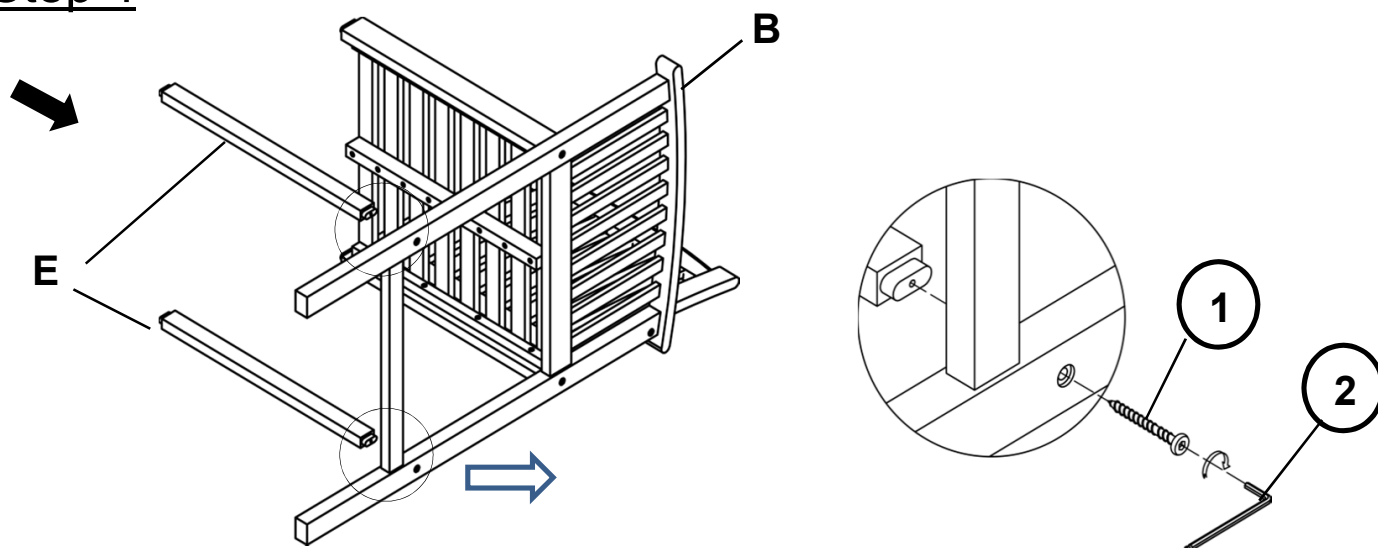

Attach Leg Support Bars(E) to Right Leg Panel(B) using Screws(①) with Allen Key(②).
Do not fully tighten Screws.

Step 5

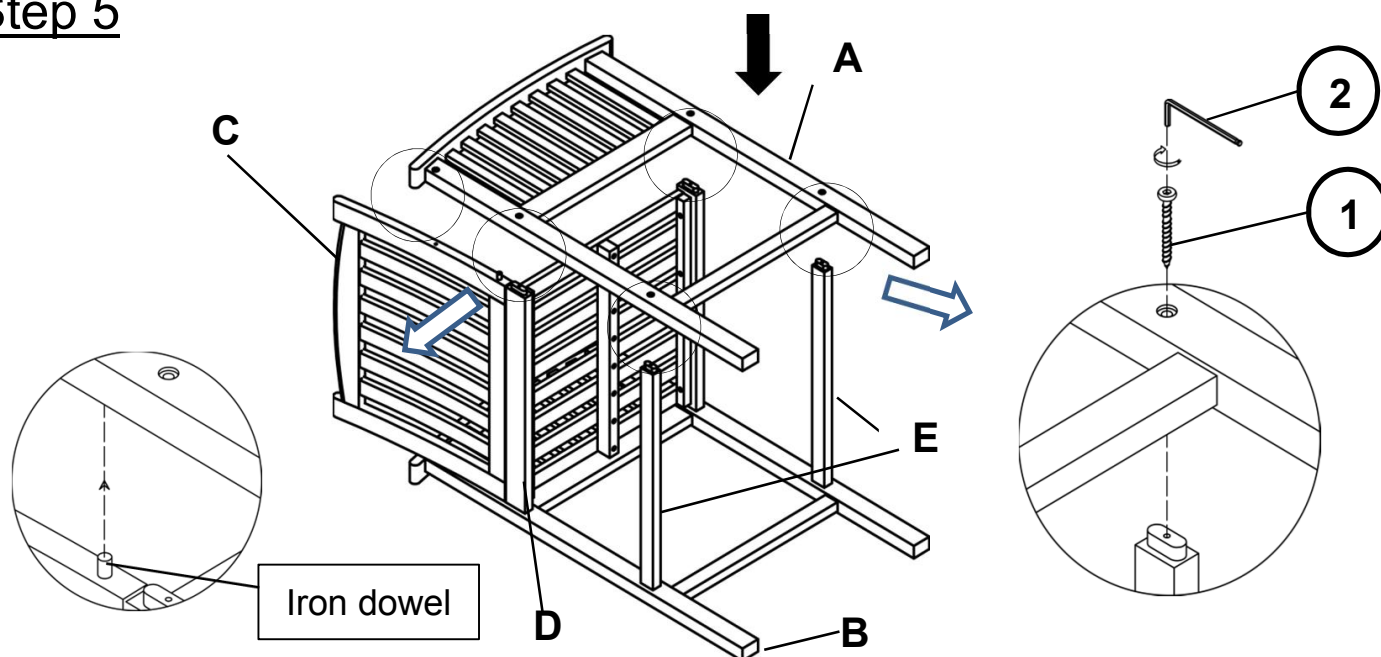

With assistance from your adult partner, carefully turn over the pre-assembled Barstool. Attach Left Leg Panel(A) to Seat Panel(D), Backrest Panel(C) and Leg Support Bars(E) using Screws(①) with Allen Key(②).
Do not fully tighten the Screws.

Step 6

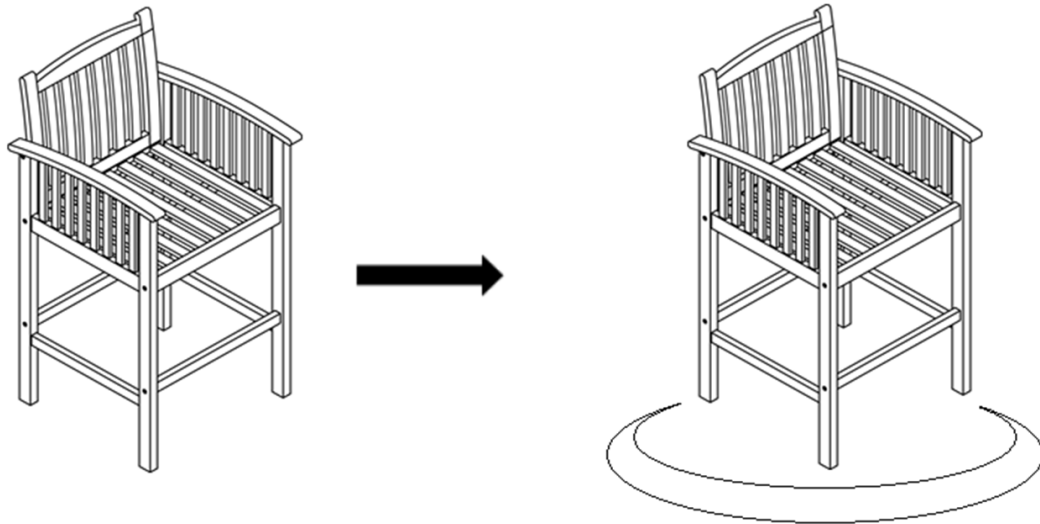

Stand the Barstool up, with assistance from your adult partner.
Exert pressure floorwards, onto the Barstool with both your hands.
This pressure will help the Legs and Barstool reach full alignment status.
Check for wobbles on a LEVEL surface.
If no wobbles are found proceed to tighten the Screws in a sequential manner,
until evenly secured.

When tightening the Screws tighten sequentially.

Do not tighten any Screw fully and then move on towards the next one.

If there are still wobbles, loosen the Screws and execute the same above process.

Step 7

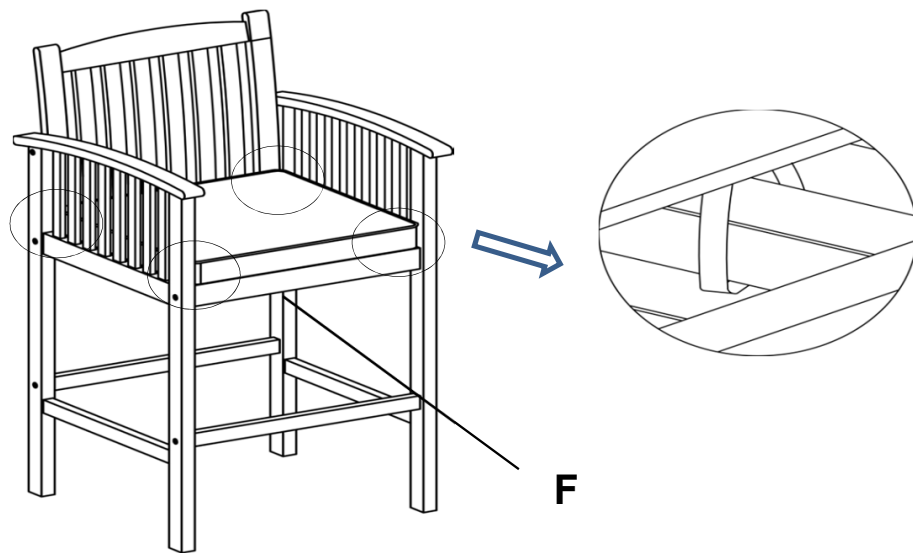



















Place Seat Cushion(C) onto the seat of the Barstool and secure the velcro straps as shown above.

Inspect the Barstool and make sure all parts are connected.

Your Barstool is ready for use.

This Barstool can only be used on a flat, level surface.

Care & Maintenance

-   ● Do not put hot items directly on furniture surface
 -   ● Do not clean furniture with harsh cleansers or polish.
 -   ● To obtain the longest lifespan of your outdoor products, minimizing exposure to direct sunlight is recommended.
 -   ● Children should not climb or jump on the furniture.
 -   ● Do not write on furniture without a padded barrier to protect the surface.
 -   ● To obtain the longest lifespan of your outdoor products, avoid extended and lengthy exposure to rain, snow, and direct sunshine. Whenever possible cover the product and /or place under patio or awnings.
 -   ● Not for commercial use. For residential use only .
 -   ● Stains may be removed with mild soap solution and damp cloth.
-
-   ● Dust and pick-up spills using a clean, non-colored, lint-free cloth .

Questions & Answers about Proposition 65

• What is Proposition 65?

Proposition 65 requires businesses to provide warnings to Californians about significant exposures to chemicals that cause cancer, birth defects or other reproductive harm. These chemicals can be in the products that Californians purchase, in their homes or workplaces, or that are released into the environment. By requiring that this information be provided, Proposition 65 enables Californians to make informed decisions about their exposures to these chemicals.

Proposition 65 also prohibits California businesses from knowingly discharging significant amounts of listed chemicals into sources of drinking water.

Proposition 65 requires California to publish a list of chemicals known to cause cancer, birth defects or other reproductive harm. This list, which must be updated at least once a year, has grown to include approximately 900 chemicals since it was first published in 1987.

• What types of chemicals are on the Proposition 65 list?

The list contains a wide range of naturally occurring and synthetic chemicals that include additives or ingredients in pesticides, common household products, food, drugs, dyes, or solvents. Listed chemicals may also be used in manufacturing and construction, or they may be byproducts of chemical processes, such as motor vehicle exhaust.

• What does a warning mean?

If a warning is placed on a product label or posted or distributed at a workplace, a business, or in rental housing, the business issuing the warning is aware or believes that it is exposing individuals to one or more listed chemicals.

By law, a warning must be given for listed chemicals unless the exposure is low enough to pose no significant risk of cancer or is significantly below levels observed to cause birth defects or other reproductive harm.