

## Assembly Instructions

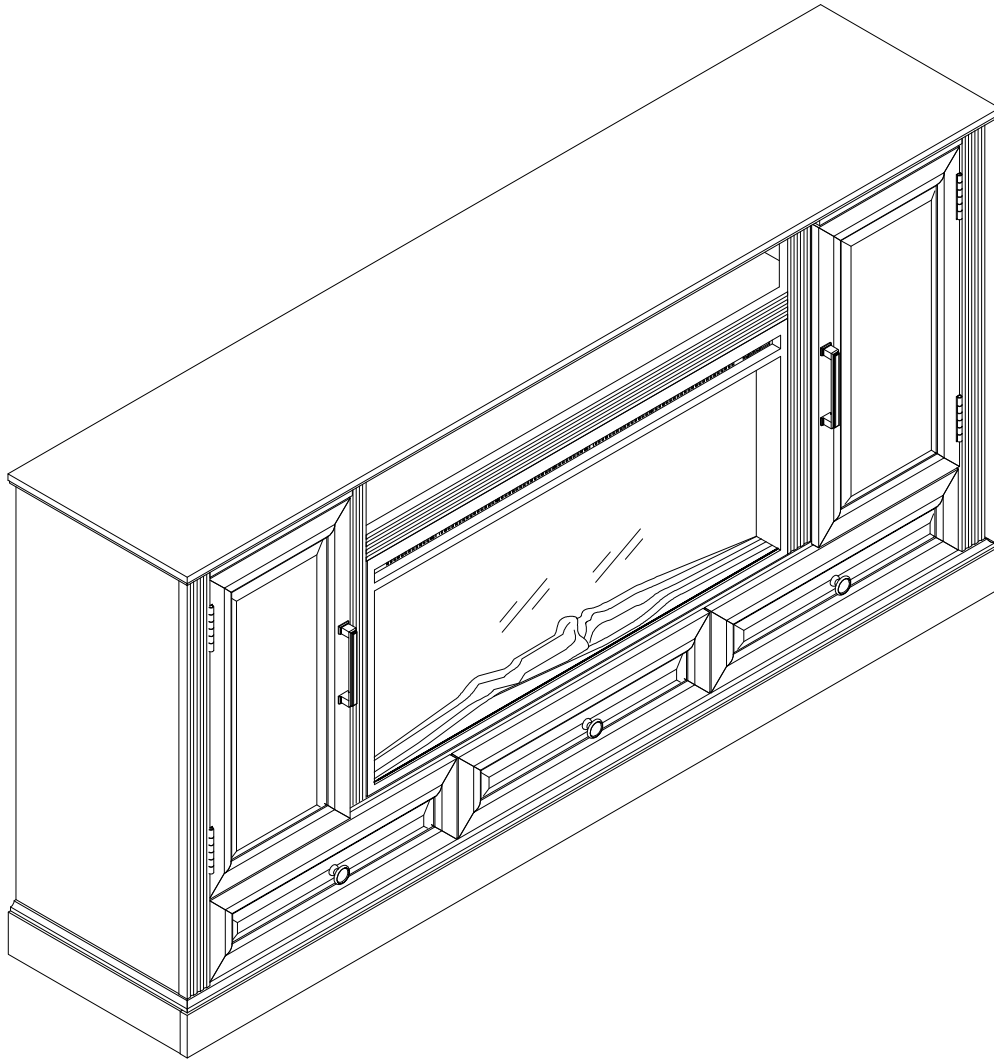

If you have any questions, please follow these steps ( “Find Your Orders” - “Problem with the Order” - “Contact Seller” ) to contact our customer service. Thanks !

NOTE: There are two packages A and B for this item. Please wait patiently if you only receive one for now

## General Assembly Guidelines

- I. Ensure that all parts and hardware are available before beginning assembly.
- II. Follow each step carefully to ensure the proper assembly of this product.
- III. Two people are recommended for ease in the assembly of this product.
- IV. The three main types of hardware used to assemble this product are : wood dowels , screws and bolts.
- V. The provided glue is to secure wood dowels in place . When first inserting dowels , locate the appropriate hole for the dowel , place a small amount of glue in the hole and insert the dowel . Wipe away excess glue immediately.

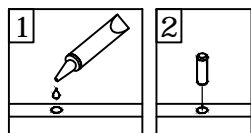

In future assembly steps when dowels are necessary to attach assembly parts together , place a small amount of glue on the end of the dowel before attaching parts together . Wipe away excess glue immediately.

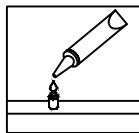

- VI. A Phillips head screwdriver is required for the assembly of this product .

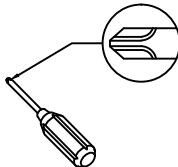



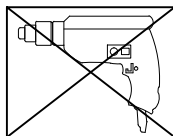



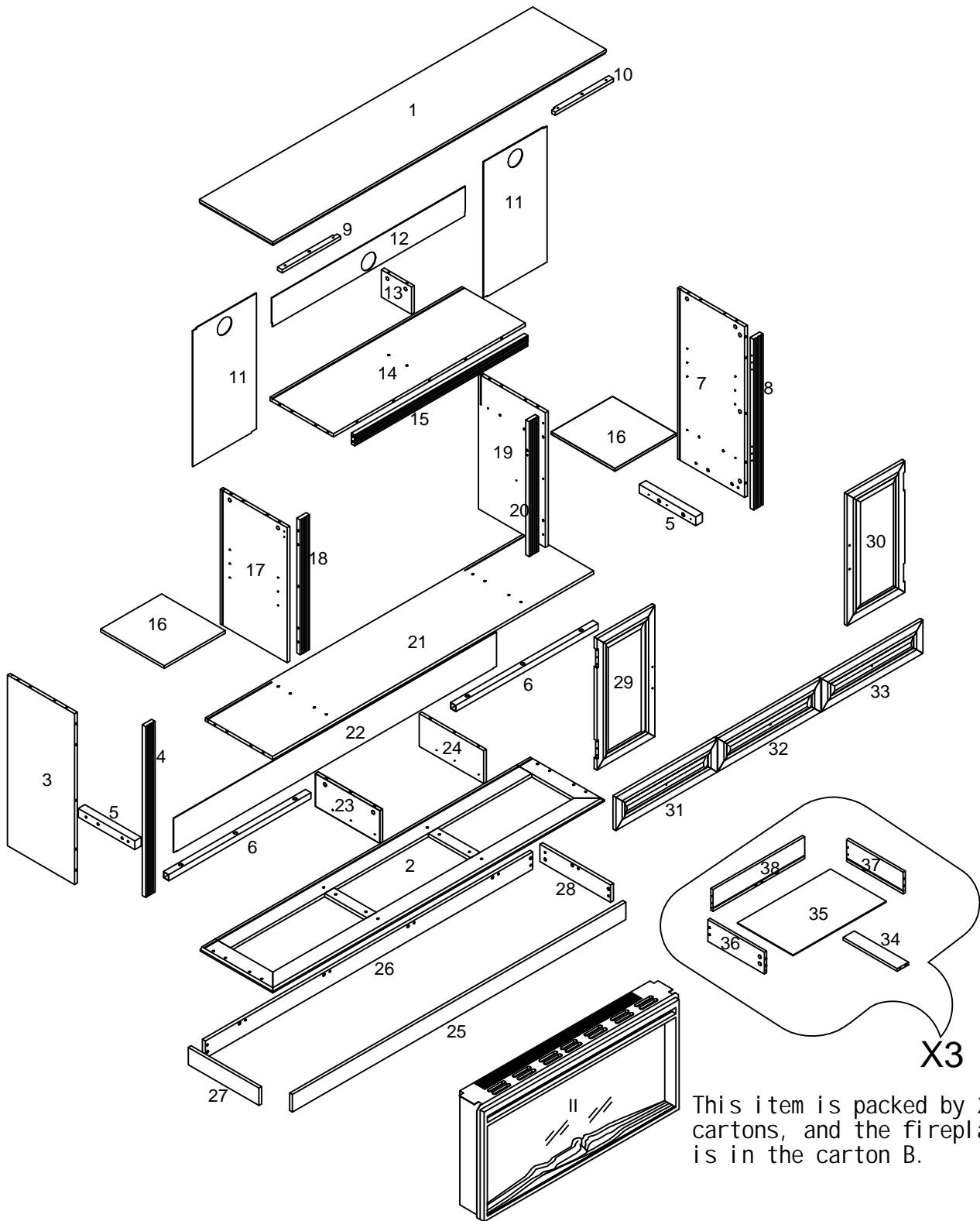







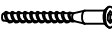

- VII. Power tools should not be used to assemble this product .

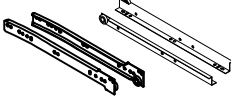

# Parts List



# Hardware List

A		Ø8x30mm	Wooden dowel	52 pcs
B		Ø6x32mm	Cam bolt	54 pcs
C		Ø15x11mm	Cam lock	39 pcs
D		Ø15x9mm	Cam lock	15 pcs
E		Ø30mm	Sticker	54 pcs
F		Ø6x50mm	Screw	14 pcs
G		M 4	Hex Key	1 pc
H		M6*12mm	Bolt	28 pcs
I			Plastic wedge	14 pcs
J		Ø4x32mm	Screw	15 pcs
K		Ø4x25mm	Screw	4 pcs
L		Ø8x20mm	Wooden dowel	2 pcs
M		12"	Drawer slides	3 Sets
N		Ø3x12mm	Screw	36 pcs
O			Hinge	4 pcs
P		Ø3.5x15mm	Screw	8 pcs
Q		Ø3.5x19mm	Screw	24 pcs
R			Door stopper	2 pcs
S		Ø3x15mm	Screw	4 pcs

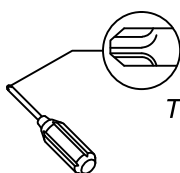

Philips head screwdriver required for assembly  
(not included)

*The hardware quantities listed above are required for proper assembly.  
Some extra hardware may also have been included.*

# Hardware List

T			Plastic wedge	22 pcs
U		Ø3x17mm	Screw	22 pcs
V		Ø6x35mm	Bolt	4 pcs
W			Screw	2 pcs
X		128mm	Handle	2 pcs
Y			Knob	3 pcs
Z		Ø4x16mm	Bolt	7 pcs
AA			Anti-inversion piece	4 pcs
BB		Ø4*15mm	Screw	4 pcs
CC			House lizard	4 pcs
DD		Ø4x35mm	Screw	4 pcs
EE			Strip	2 pcs
FF		Ø5x13x26mm	Shelf holder	8 pcs
GG		Ø6x22mm	Bolt	6 pcs
HH			Glue tube	2 pcs

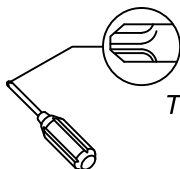

Philips head screwdriver required for assembly  
(not included)

*The hardware quantities listed above are required for proper assembly.  
Some extra hardware may also have been included.*

# Step 1

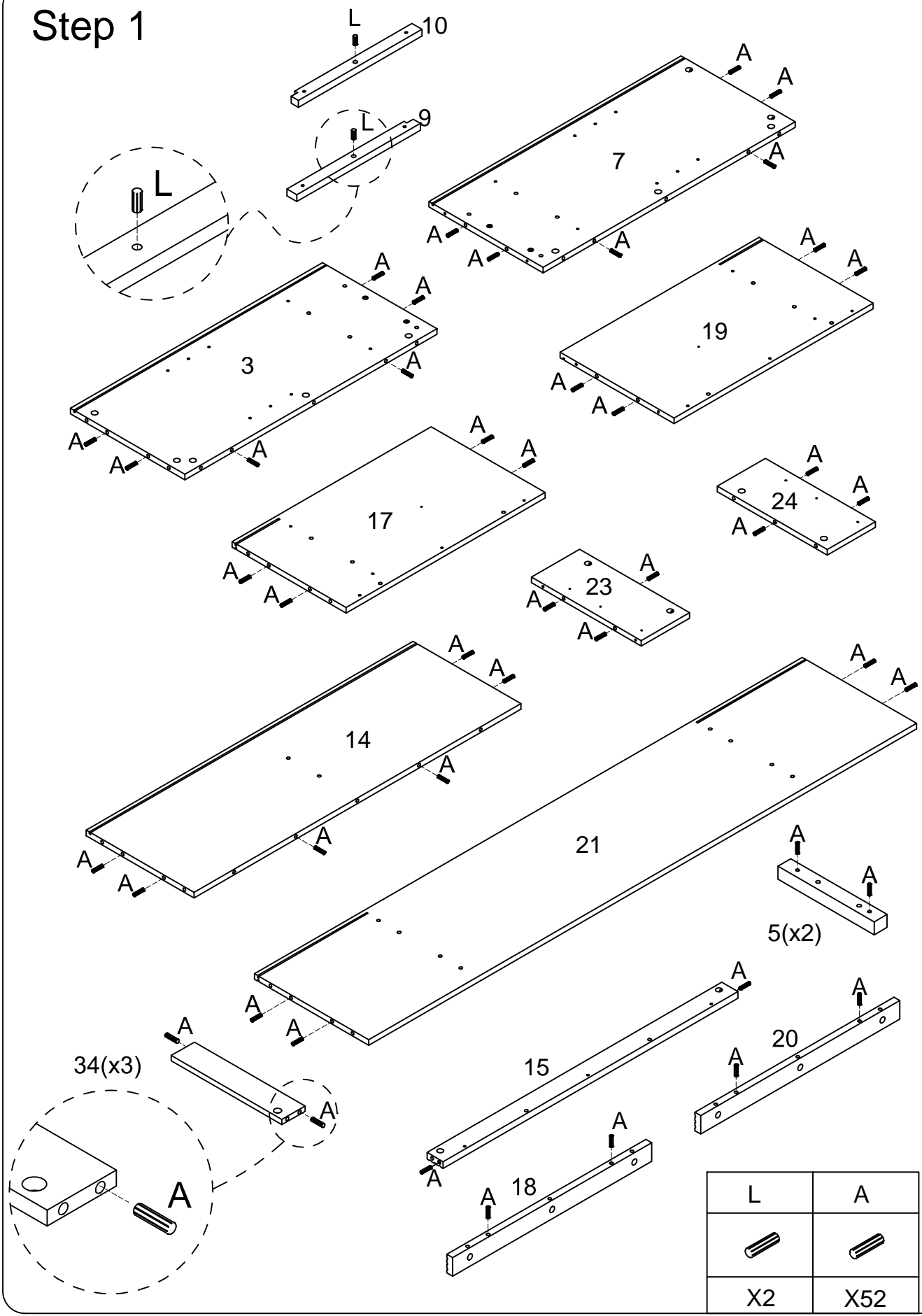

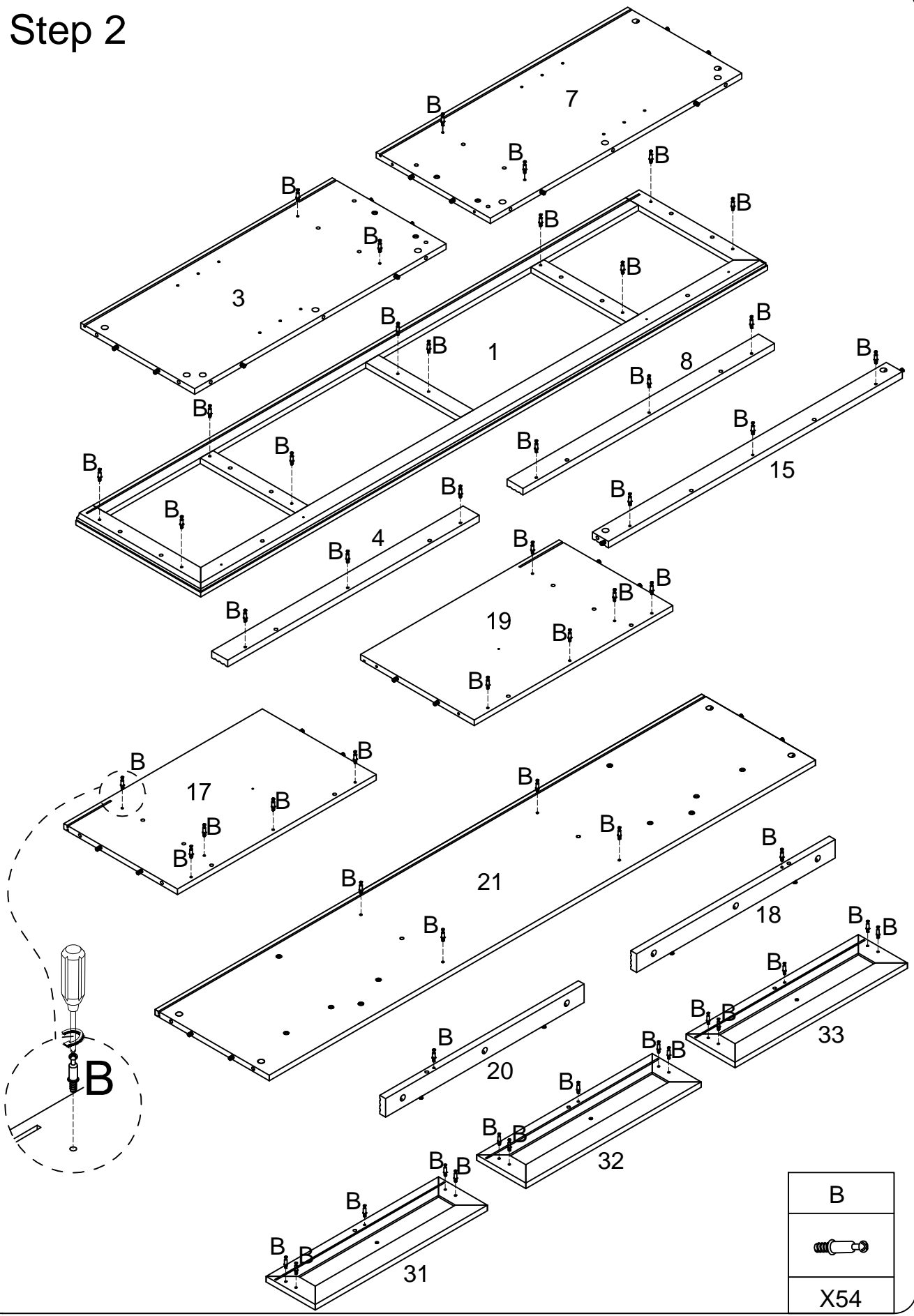

# Step 2

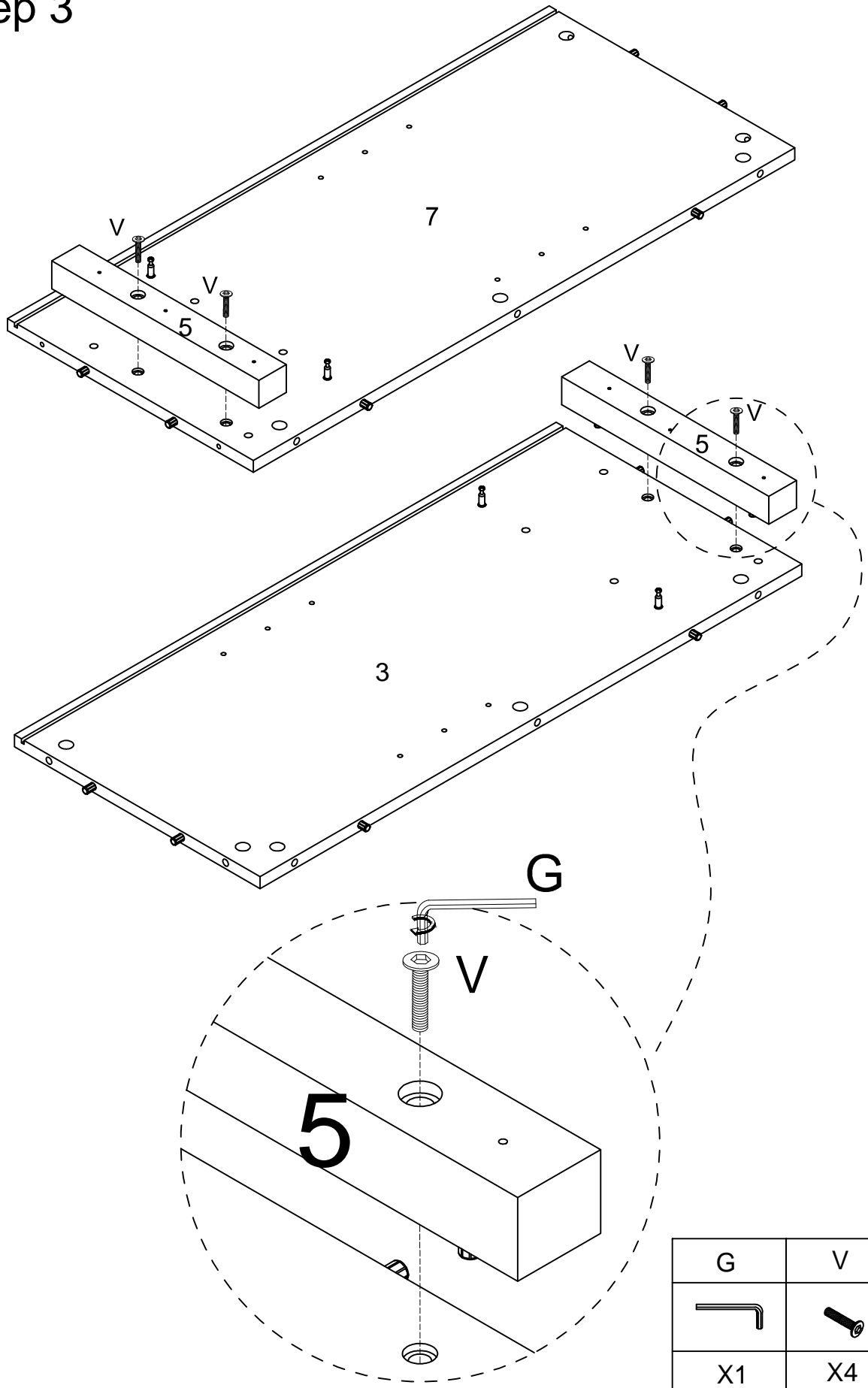

B

X54

# Step 3



G	V
	
X1	X4

# Step 4

M-CL



M-CR

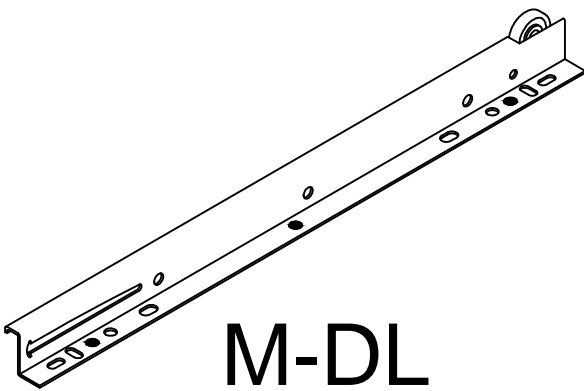
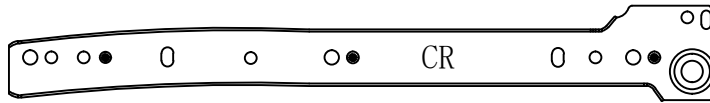

M-DL

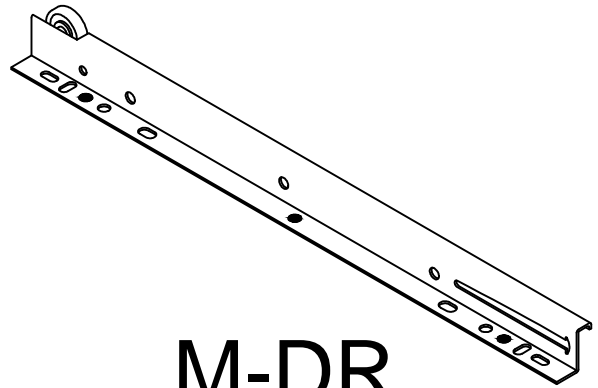

M-DR

# Step 5

NOTE:



Refer to the images to identify M-CL (left) and M-CR (right). Attach M-CL to #3 panel and M-CR to #7 panel. [N] screws must go in the exact spots shown.

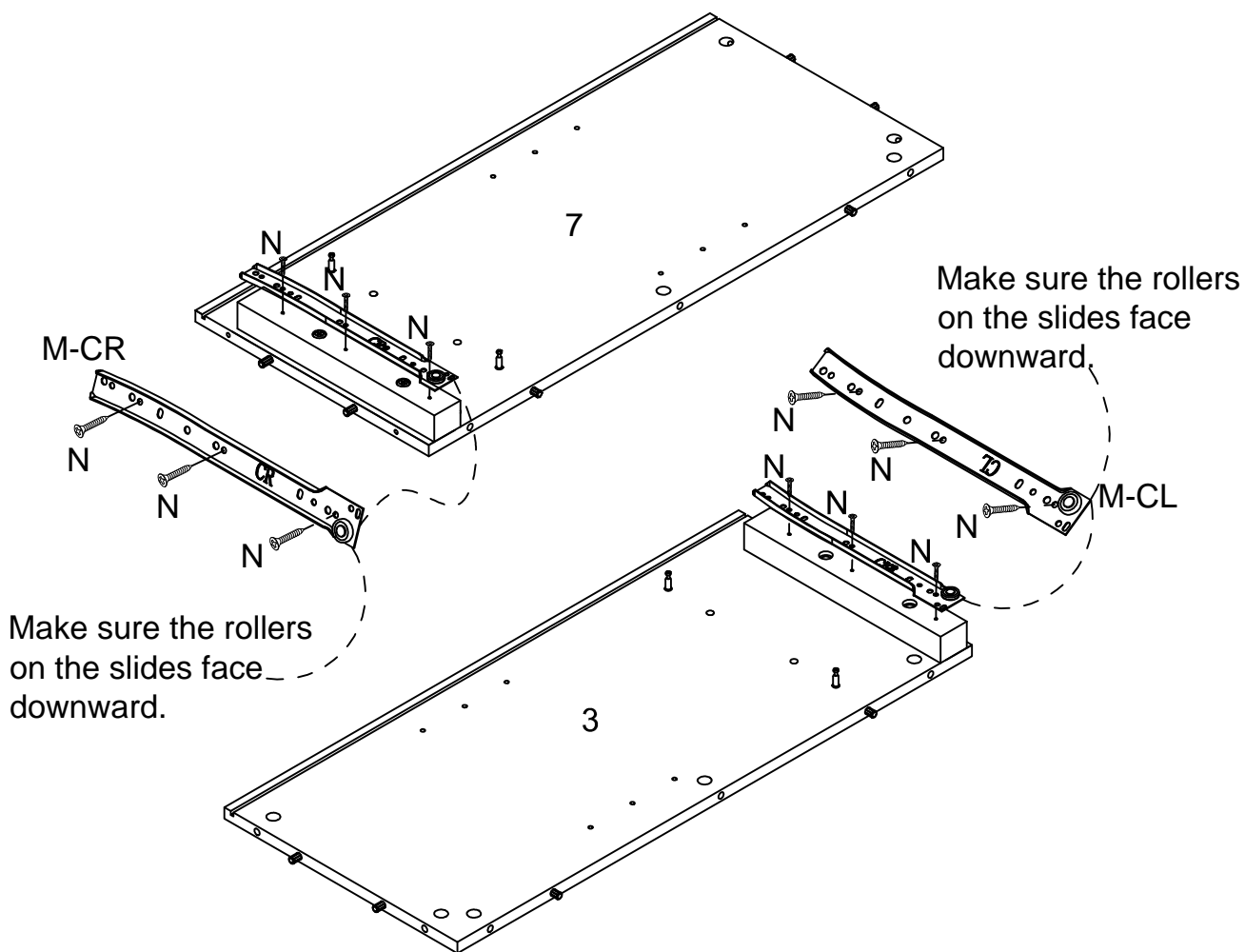
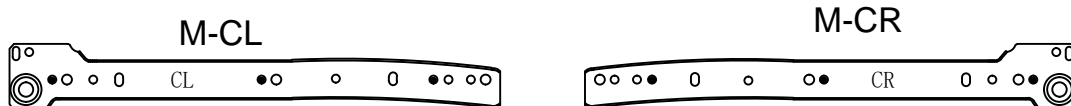

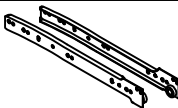
N	M
	
X6	X1

# Step 6

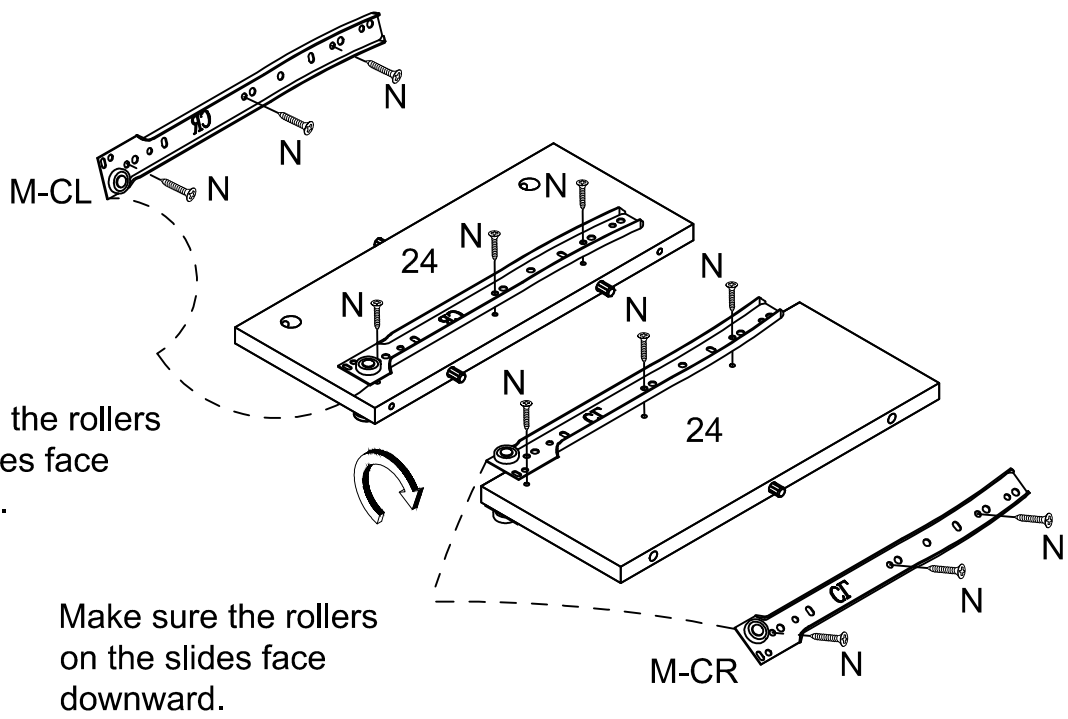

Make sure the rollers on the slides face downward.

Make sure the rollers on the slides face downward.

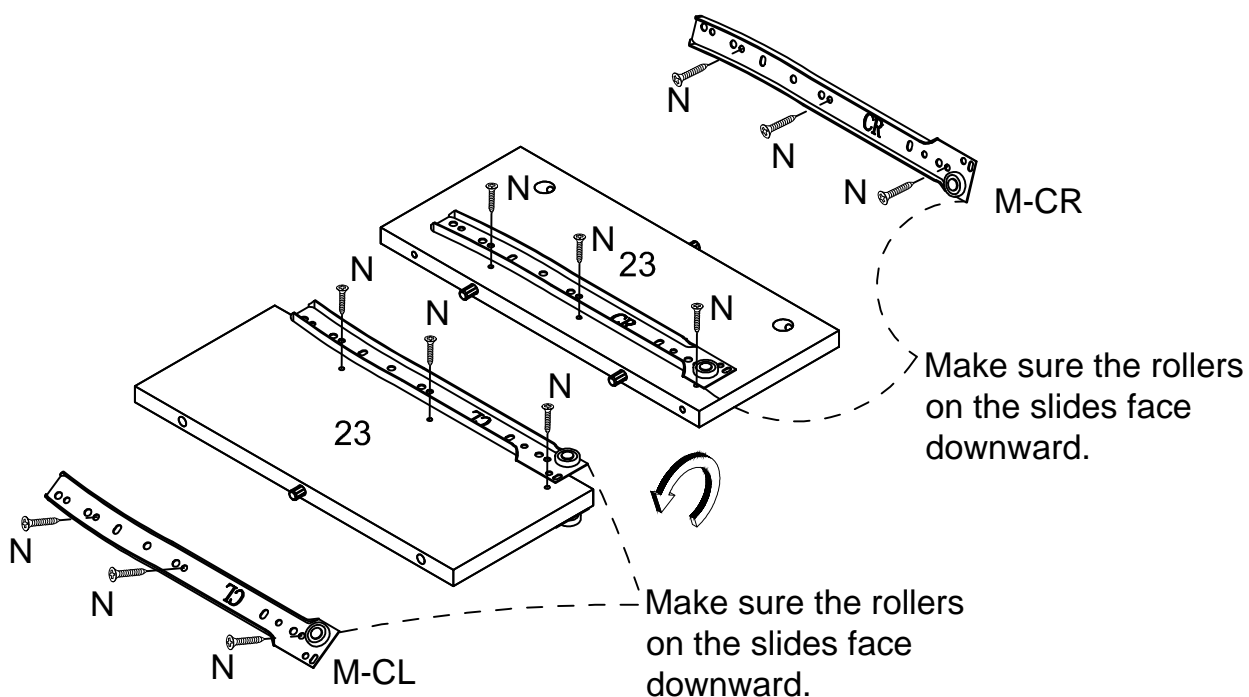

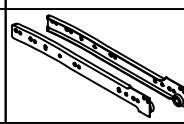

Make sure the rollers on the slides face downward.

Make sure the rollers on the slides face downward.

N	M
	
X12	X2

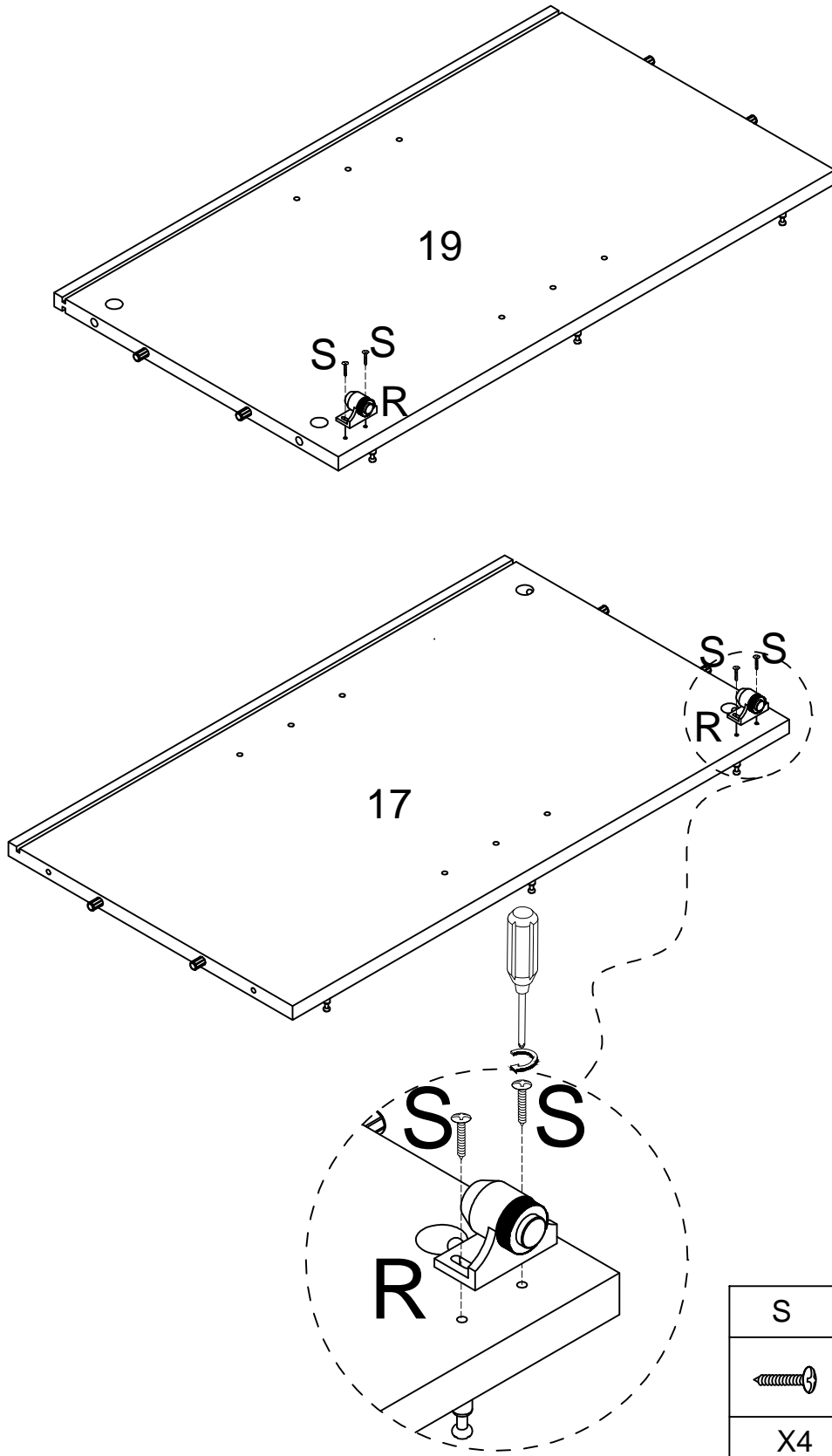
# Step 7



S	R
	
X4	X2

# Step 8

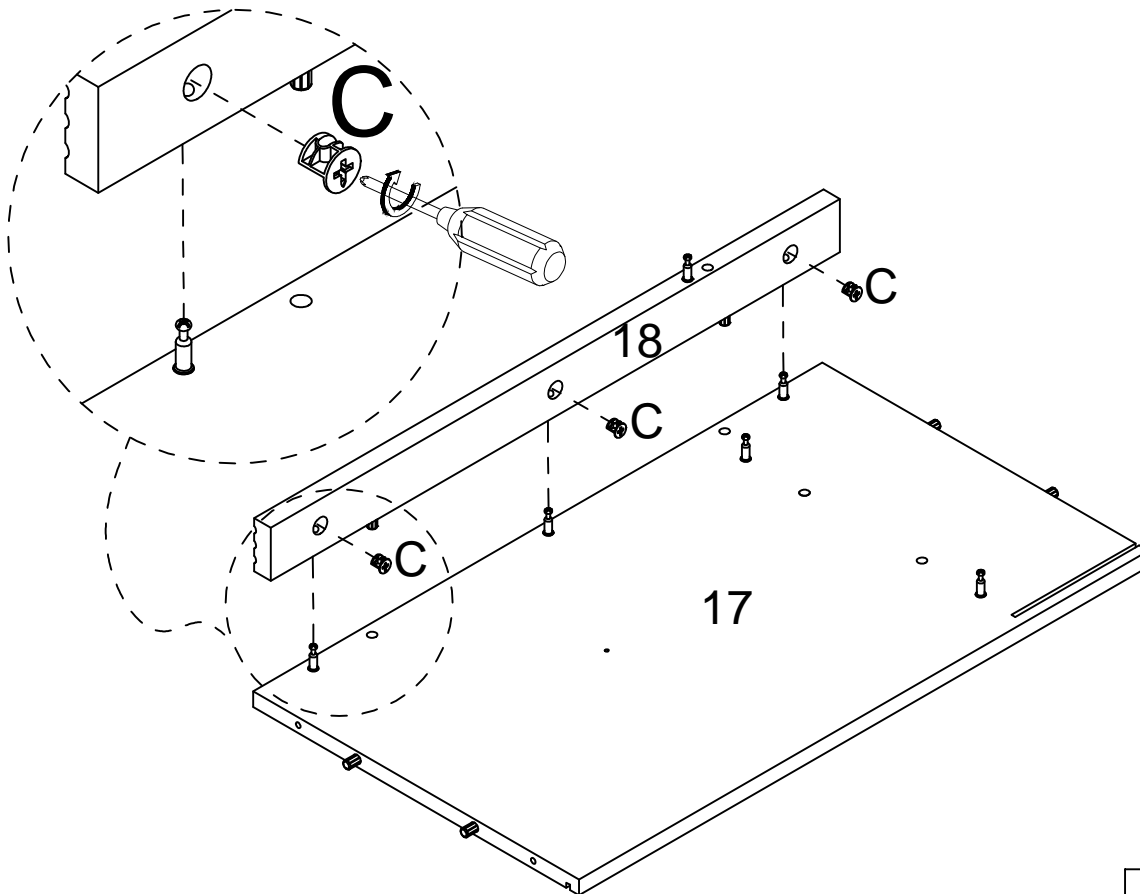
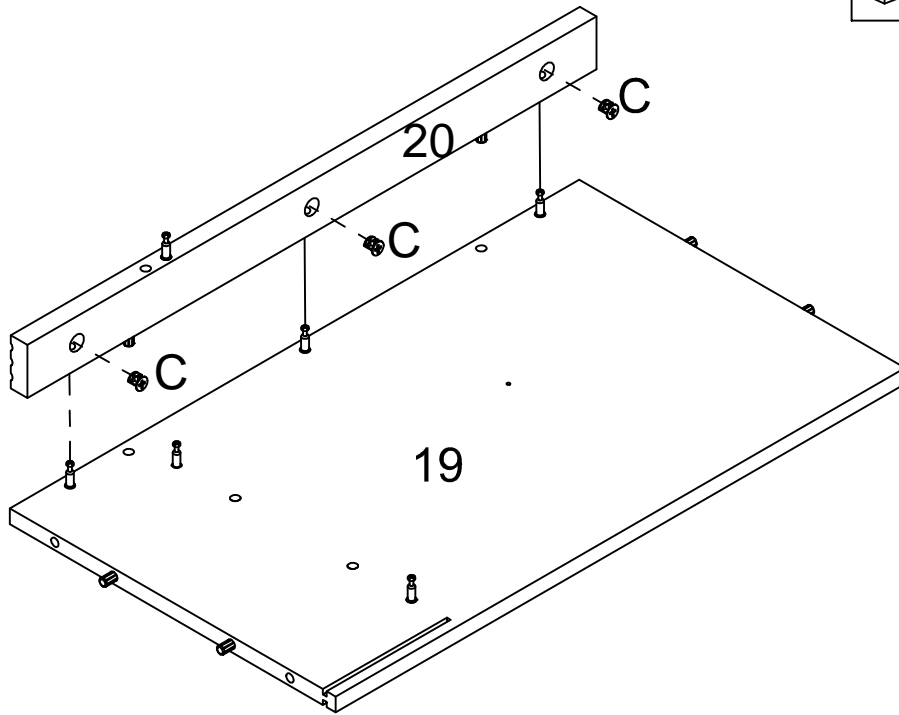
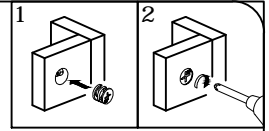

C

X6

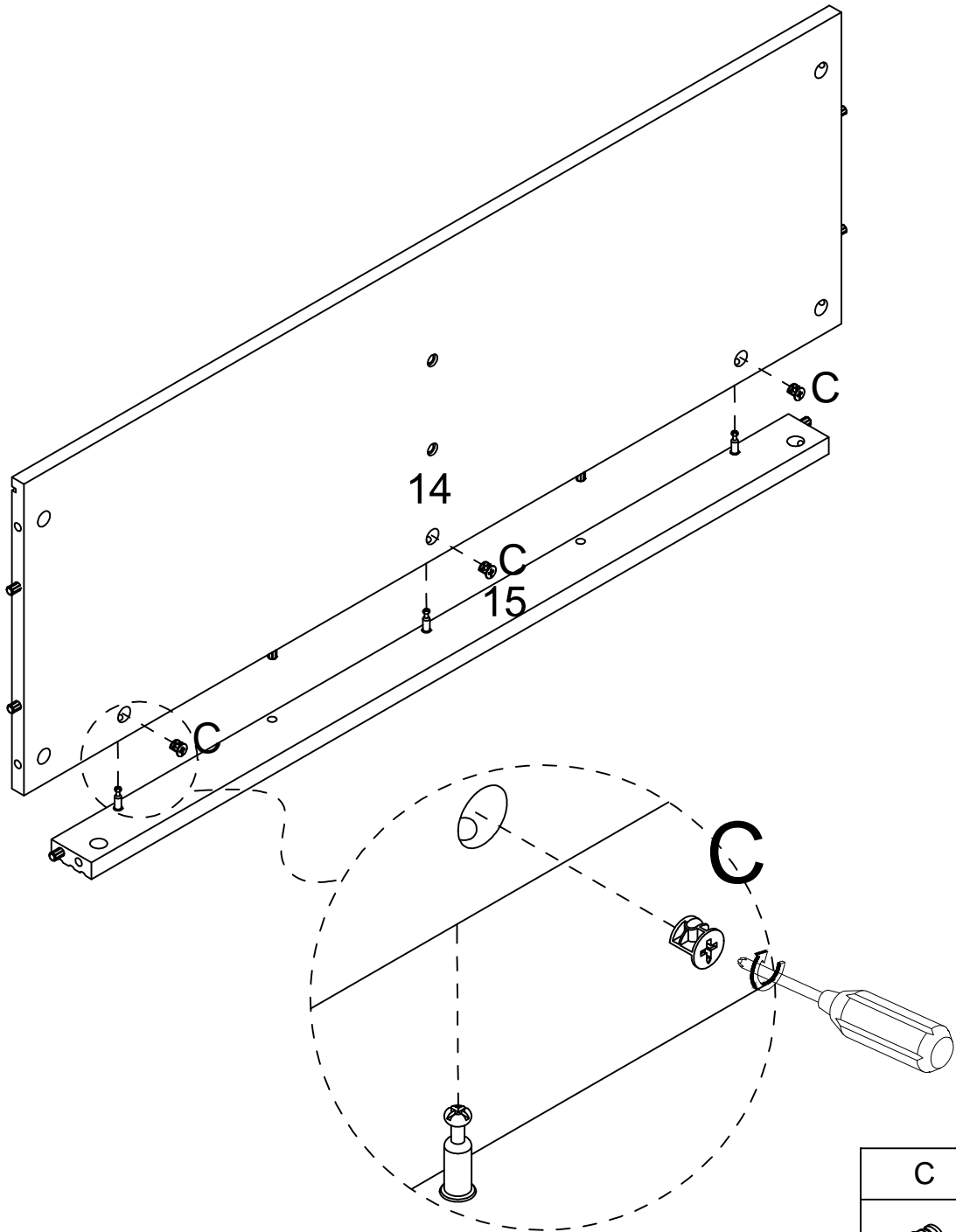
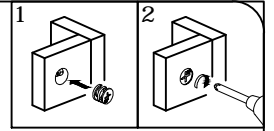
# Step 9

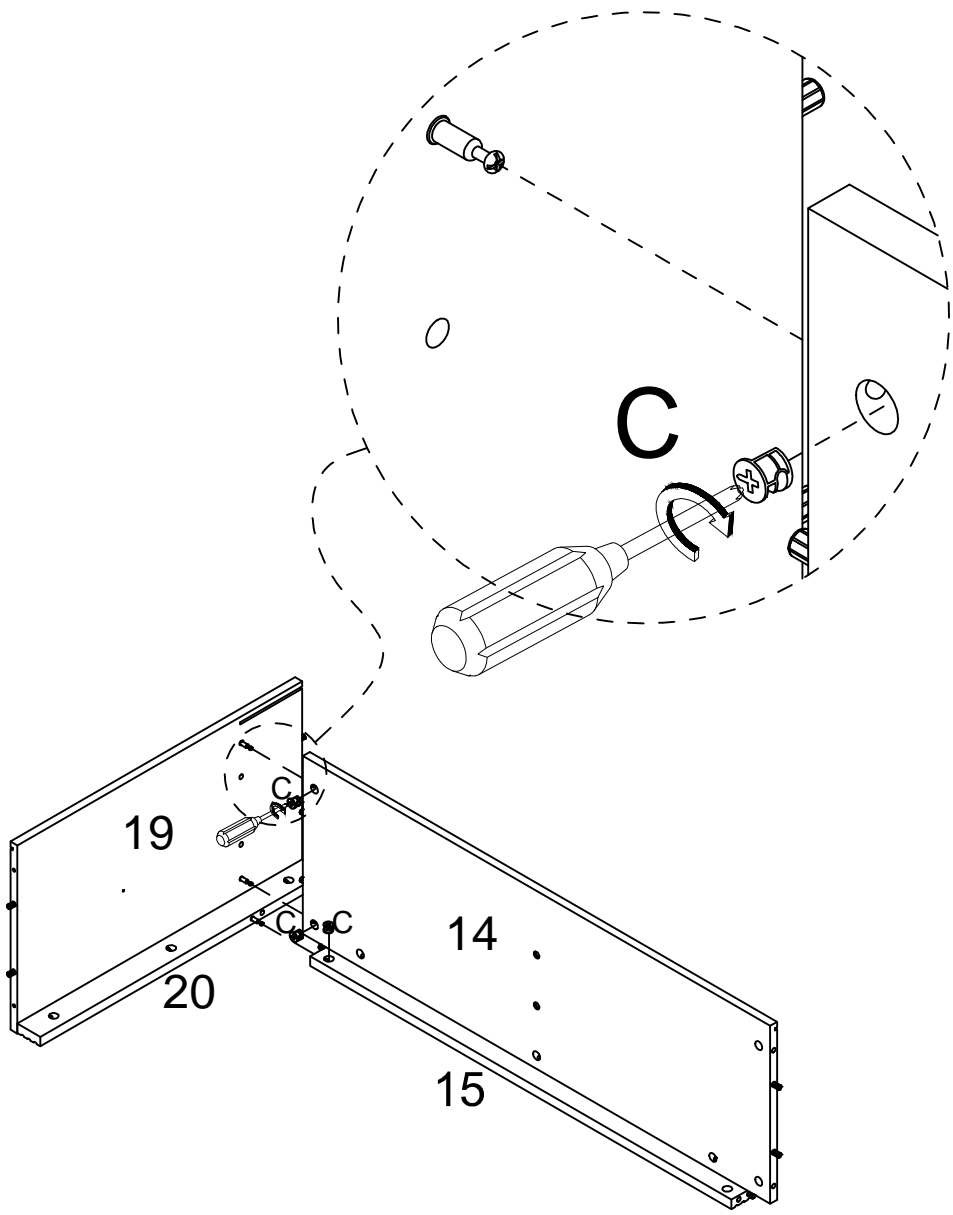
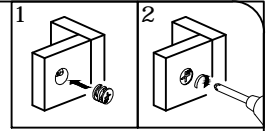

C

X3

# Step 10

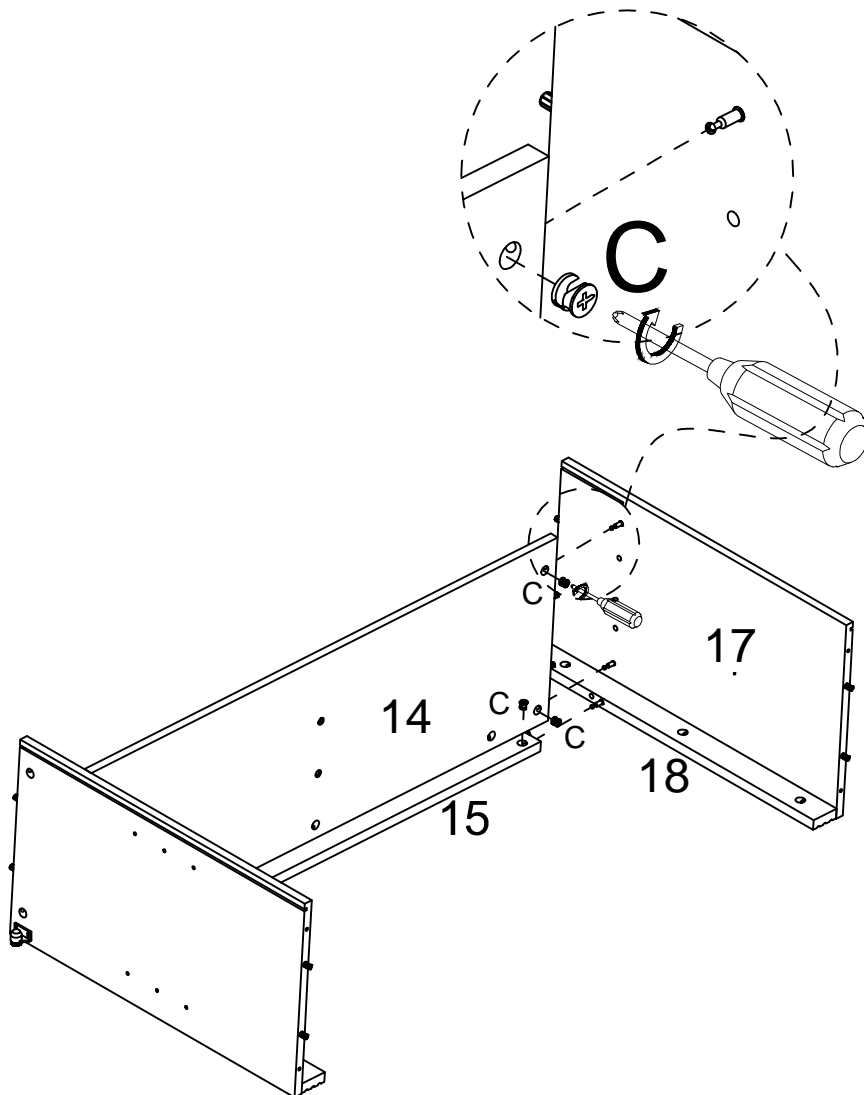
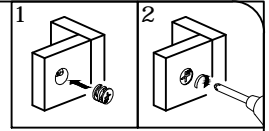

C

X3



# Step 11

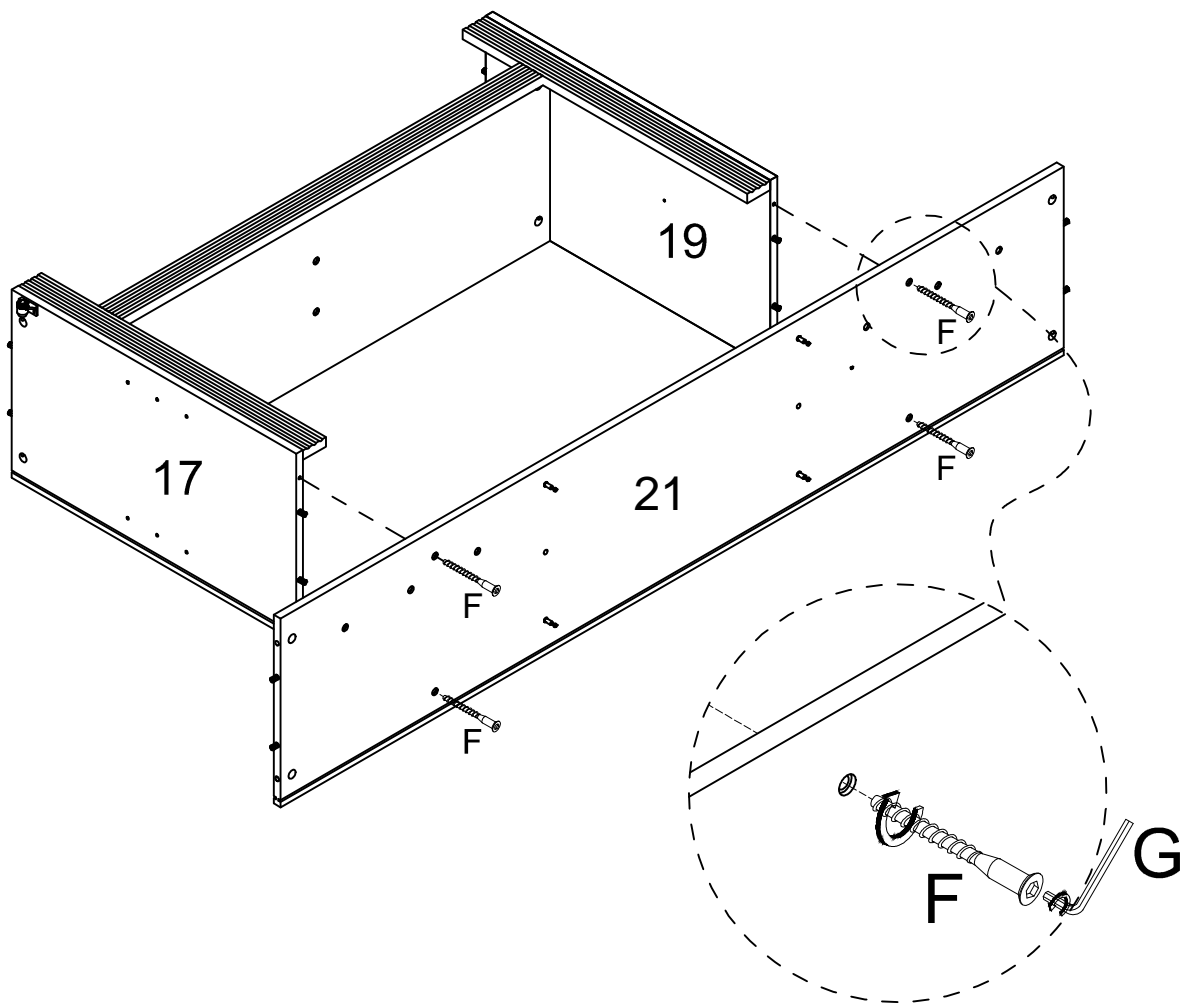

C

X3



# Step 12

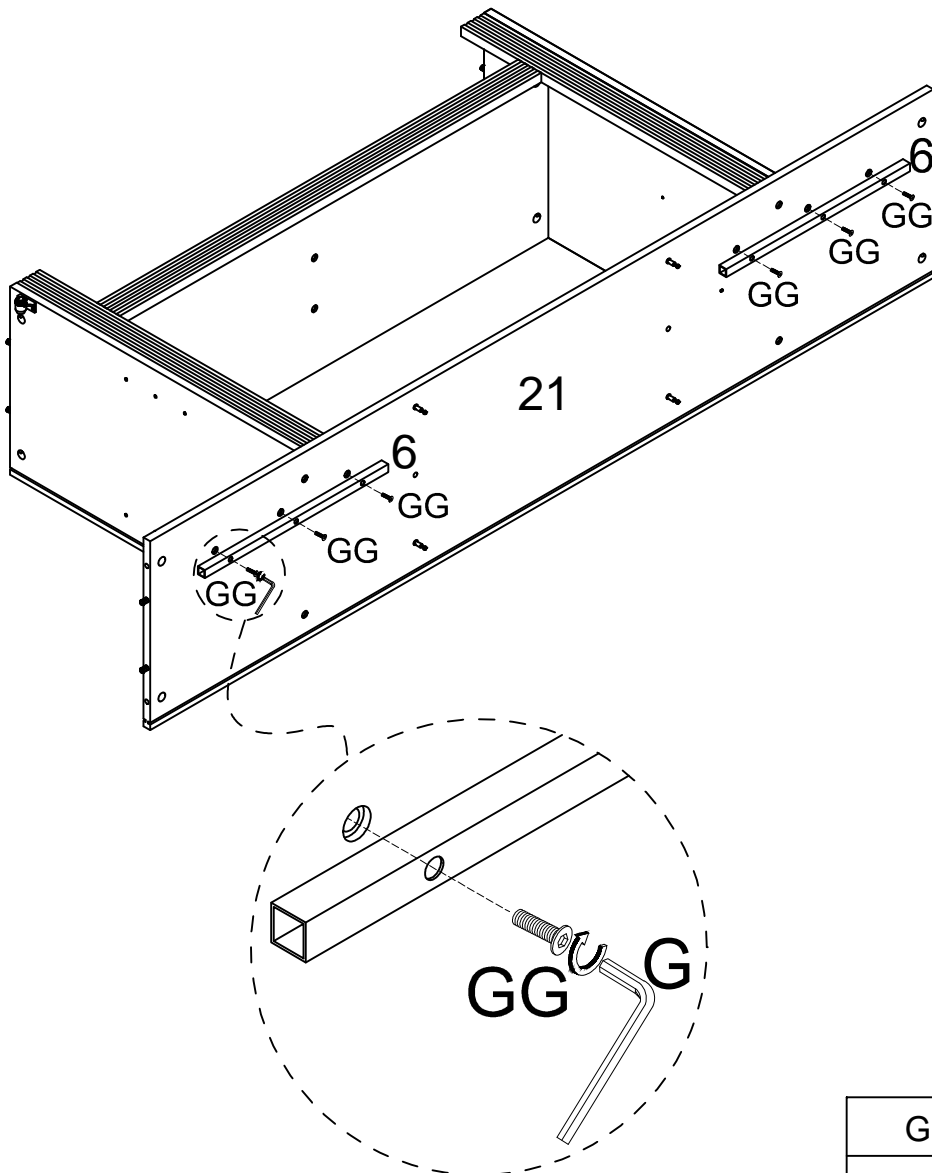

G	F
	
X1	X4

# Step 13



G	GG
	
X1	X6

# Step 14

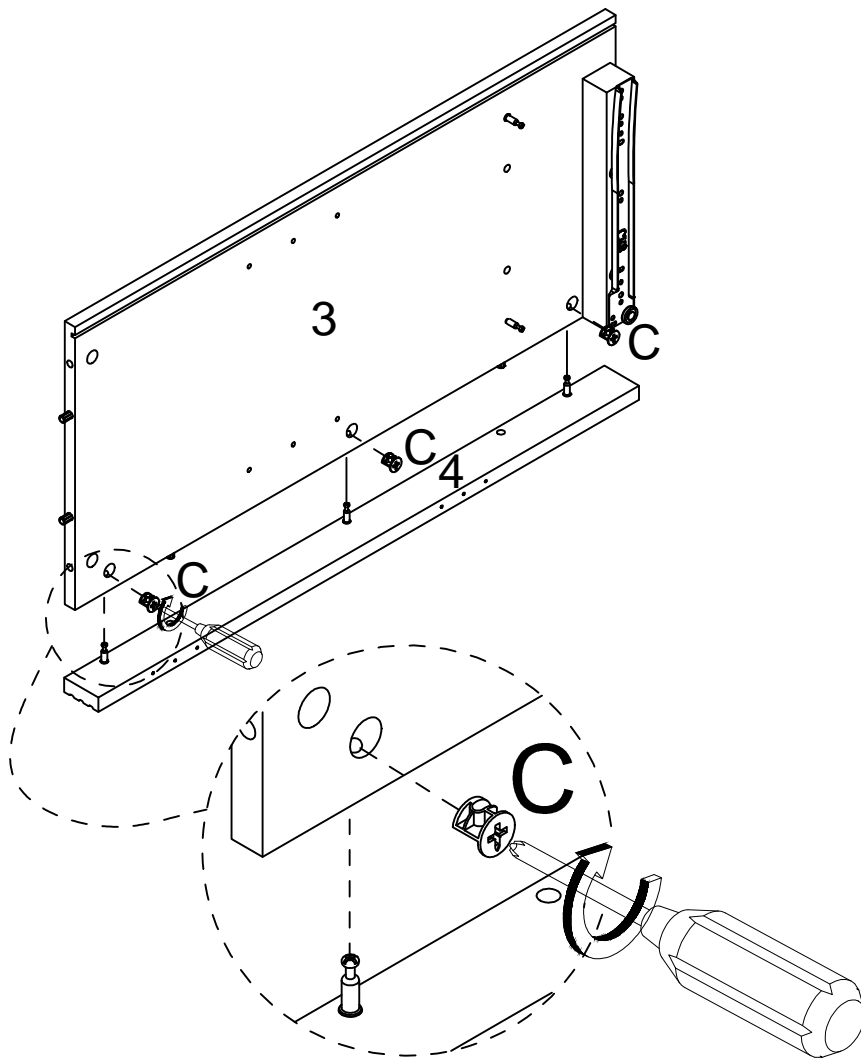
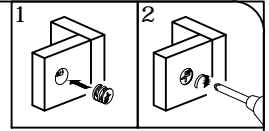

C

X3

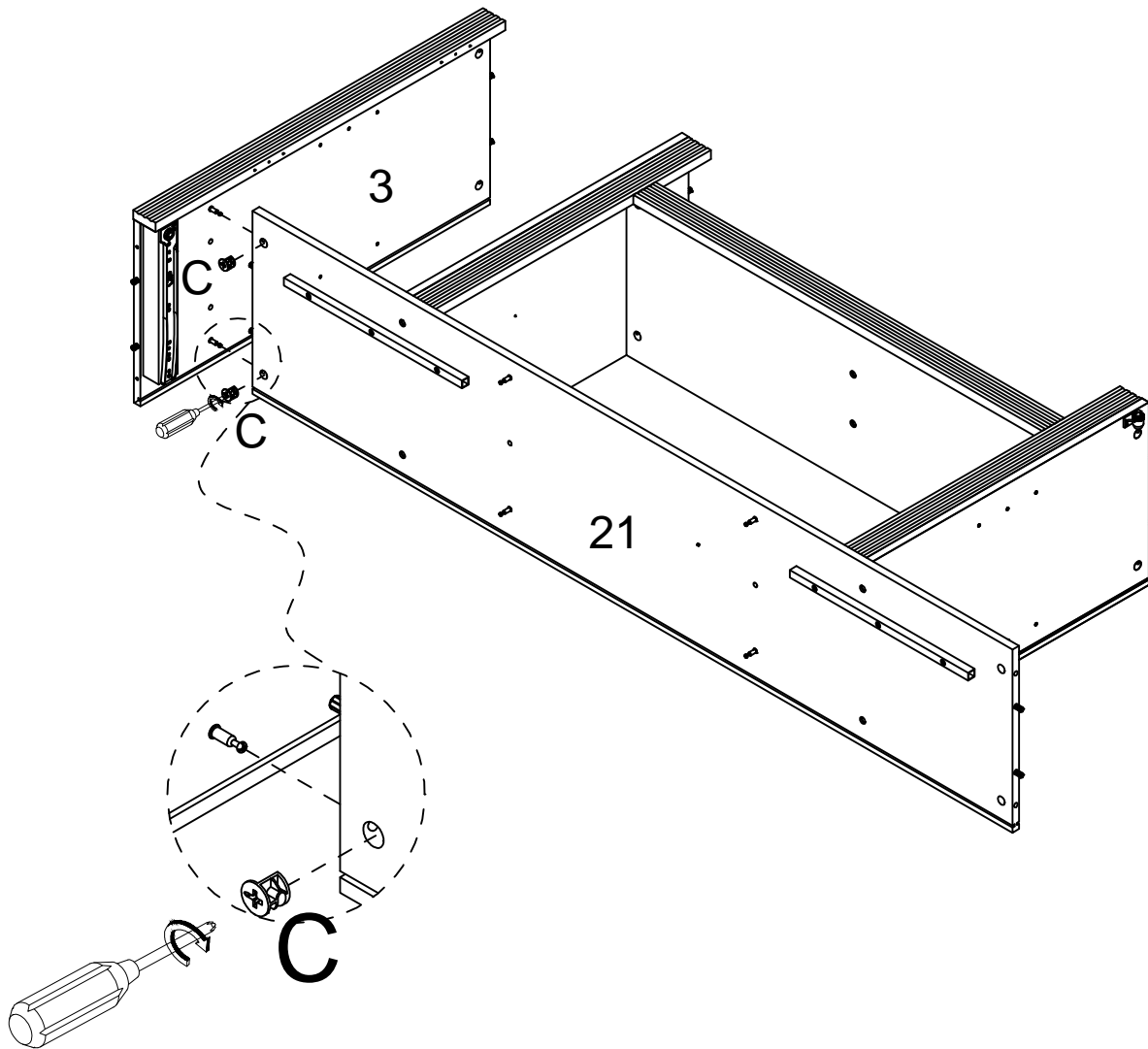
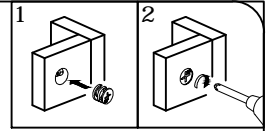
# Step 15

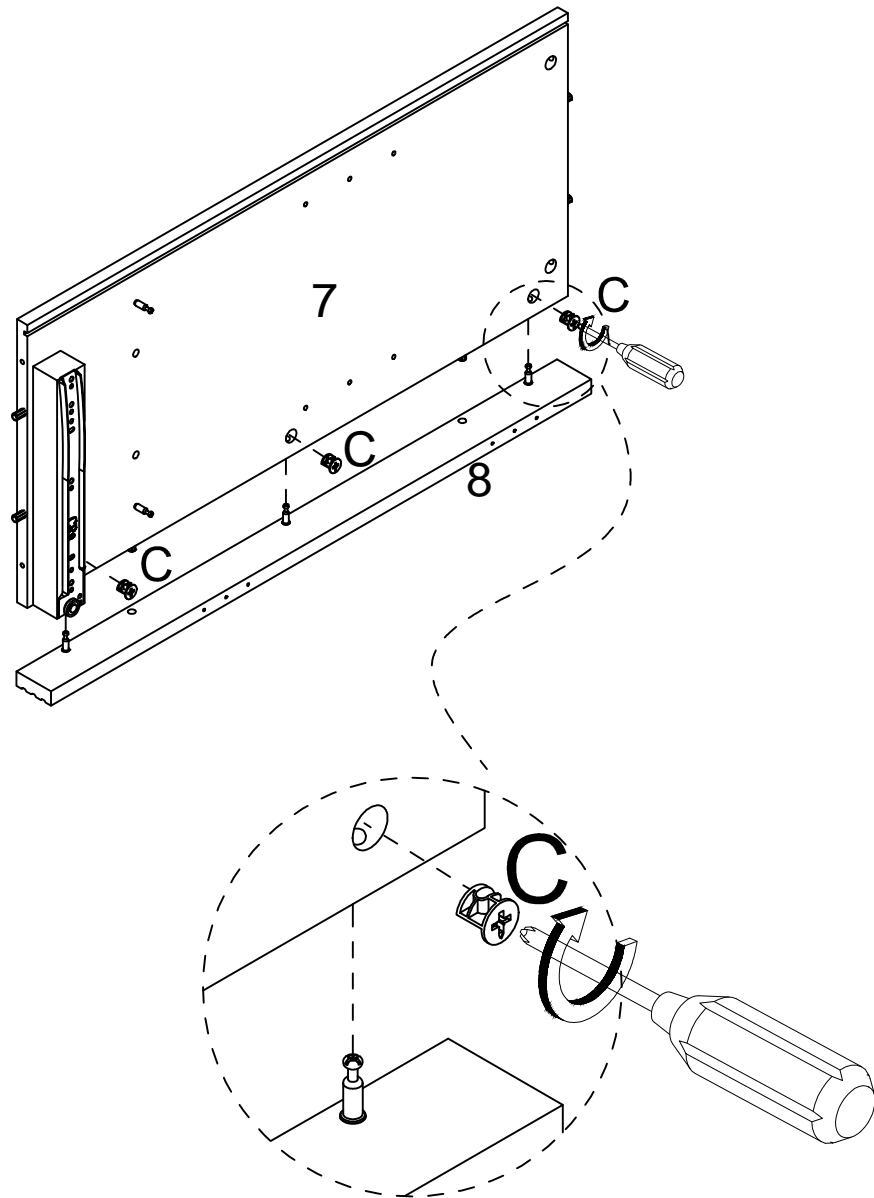
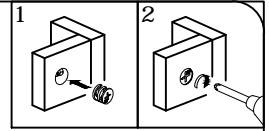

C

X2

# Step 16

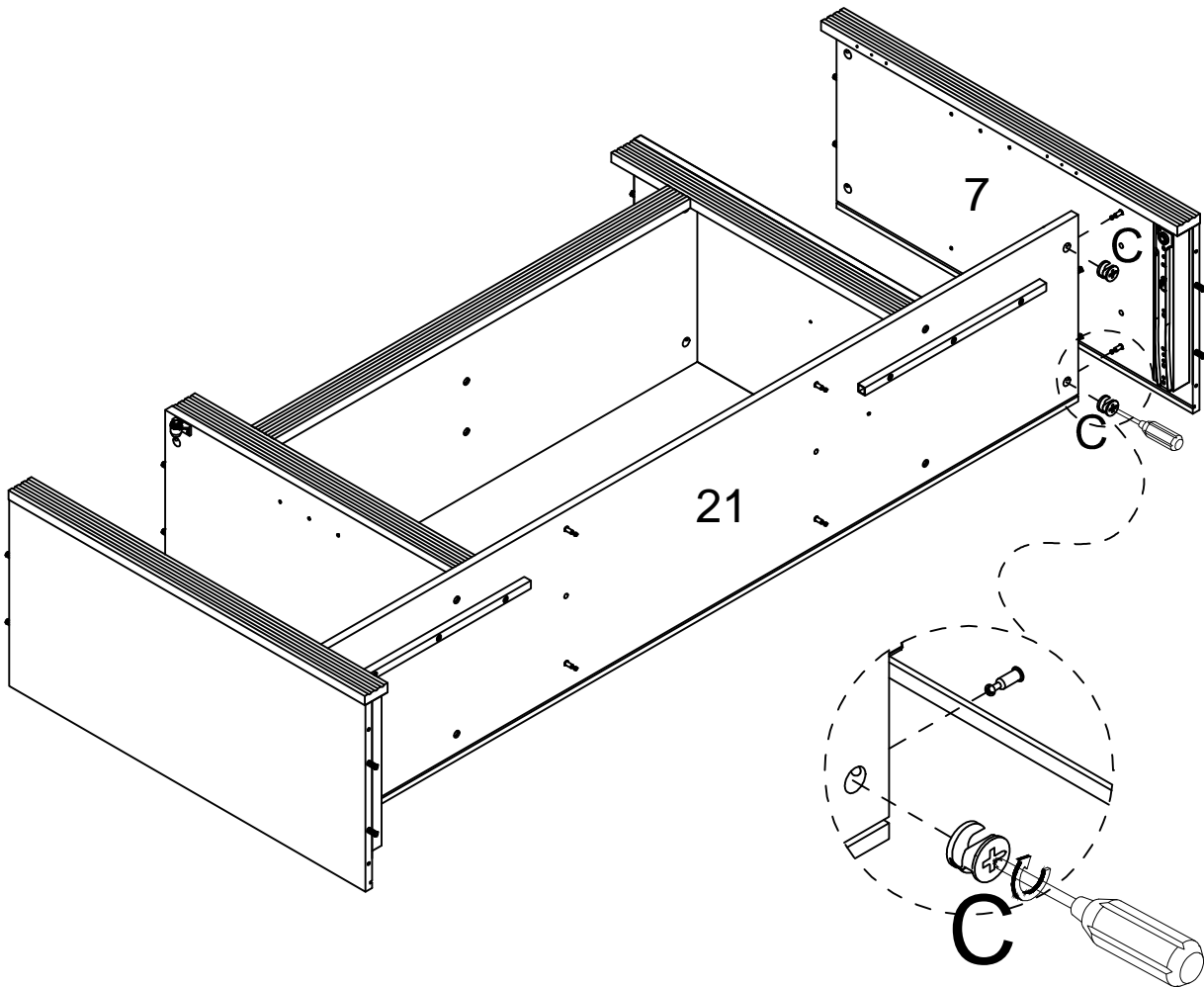
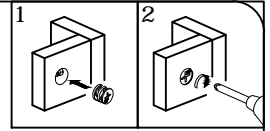

C

X3

# Step 17

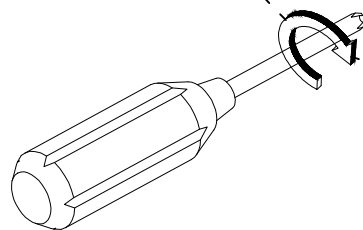
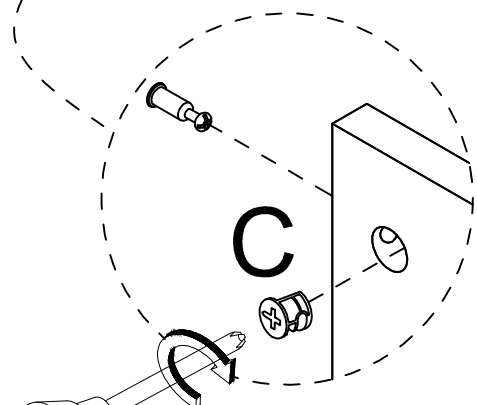
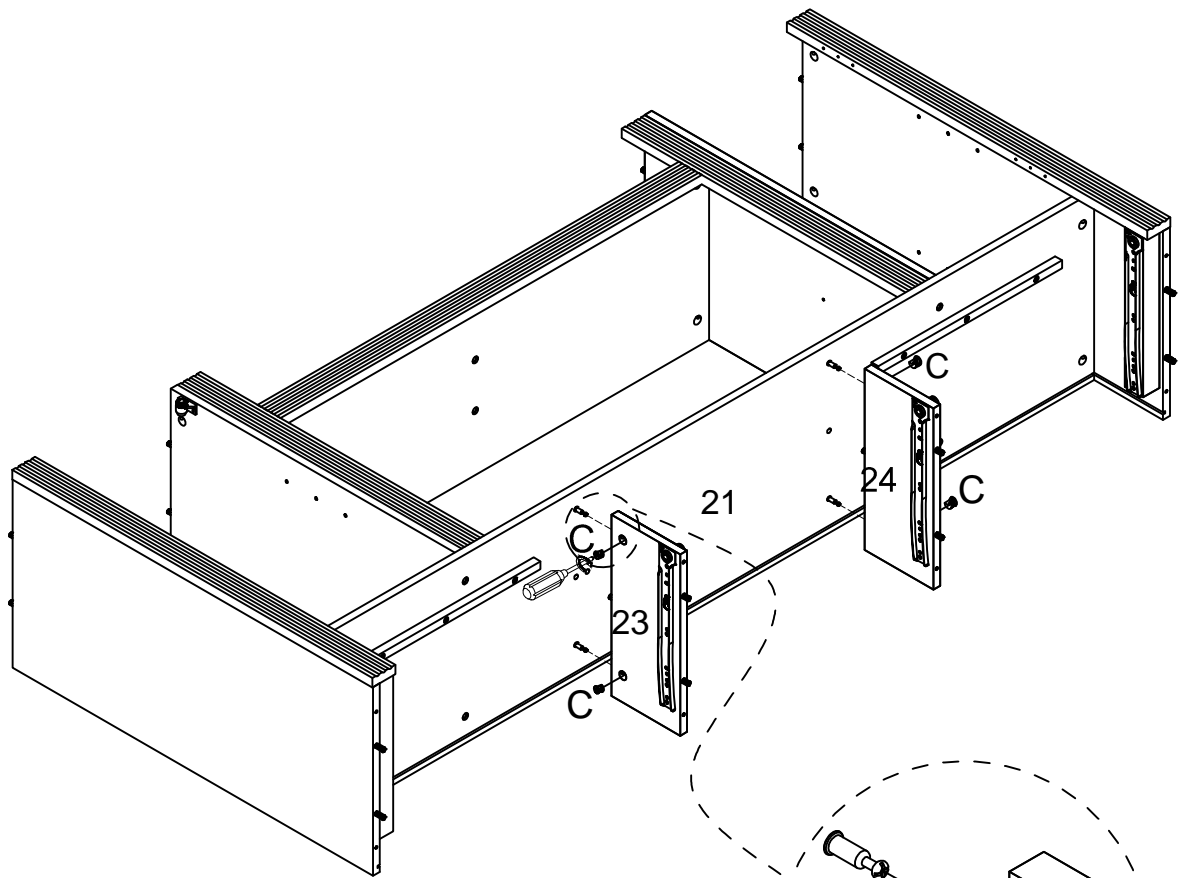
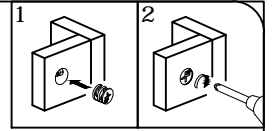

C

X2

# Step 18





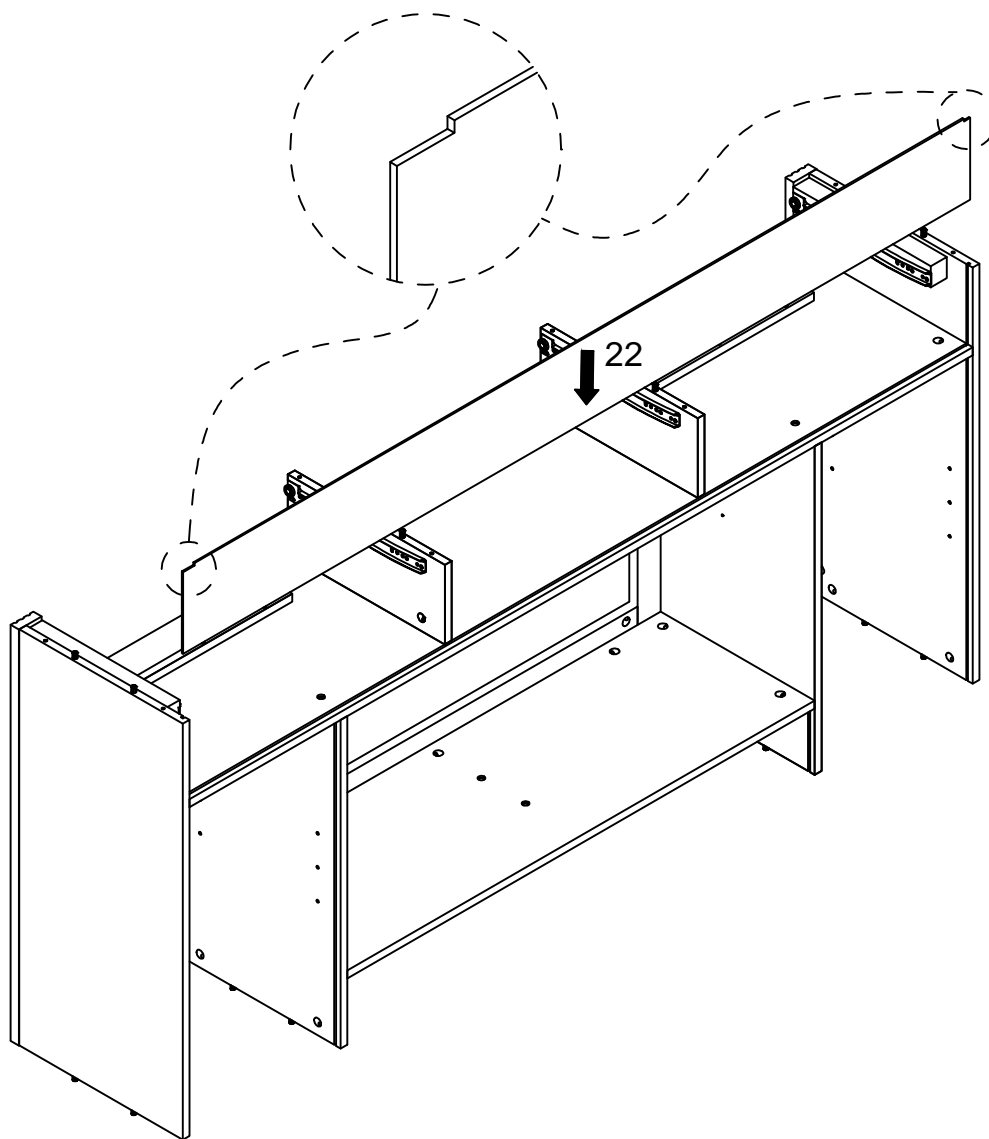

C

X4

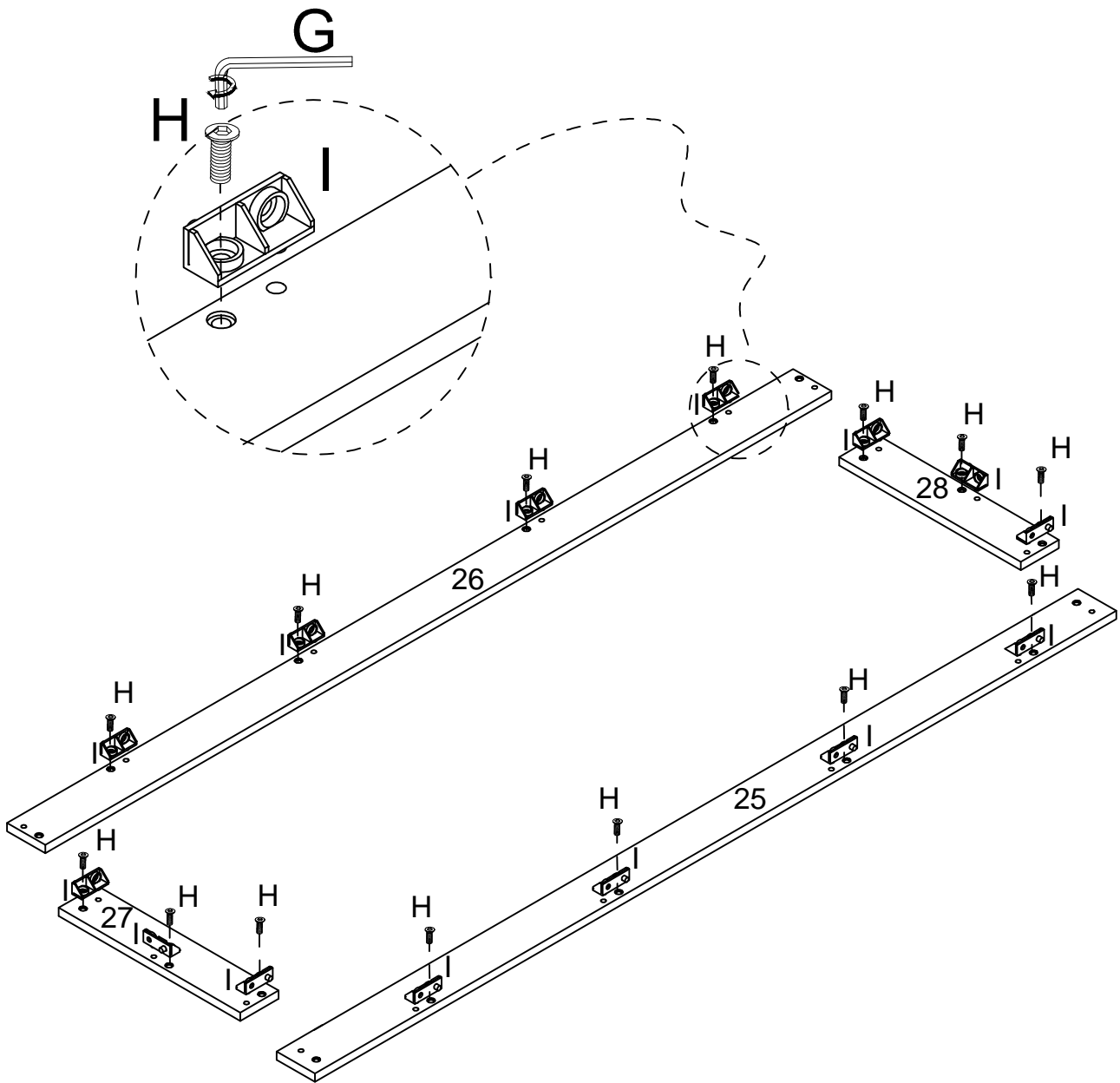
# Step 19





# Step 20



G	I	H
		
X1	X14	X14

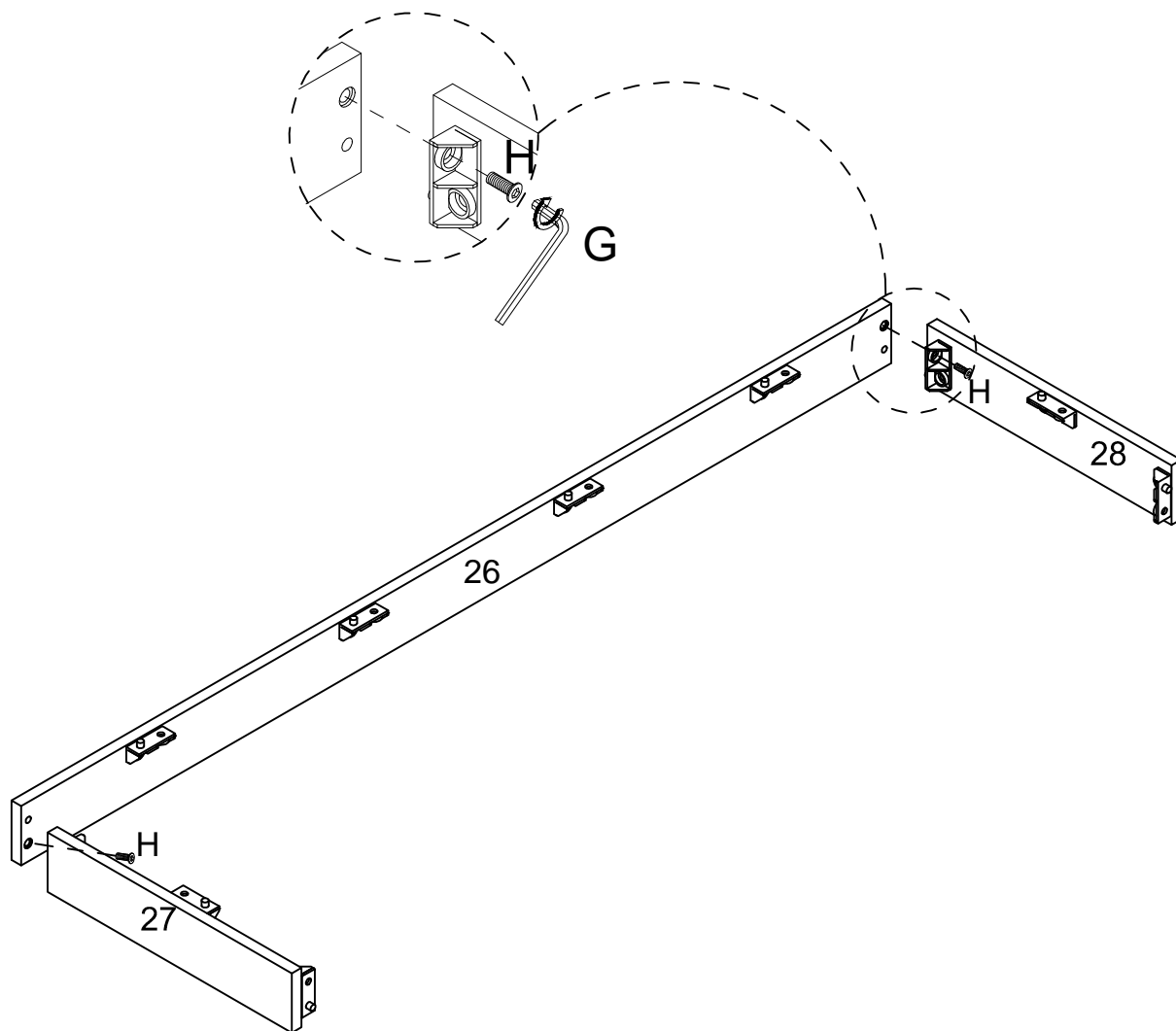

# Step 21

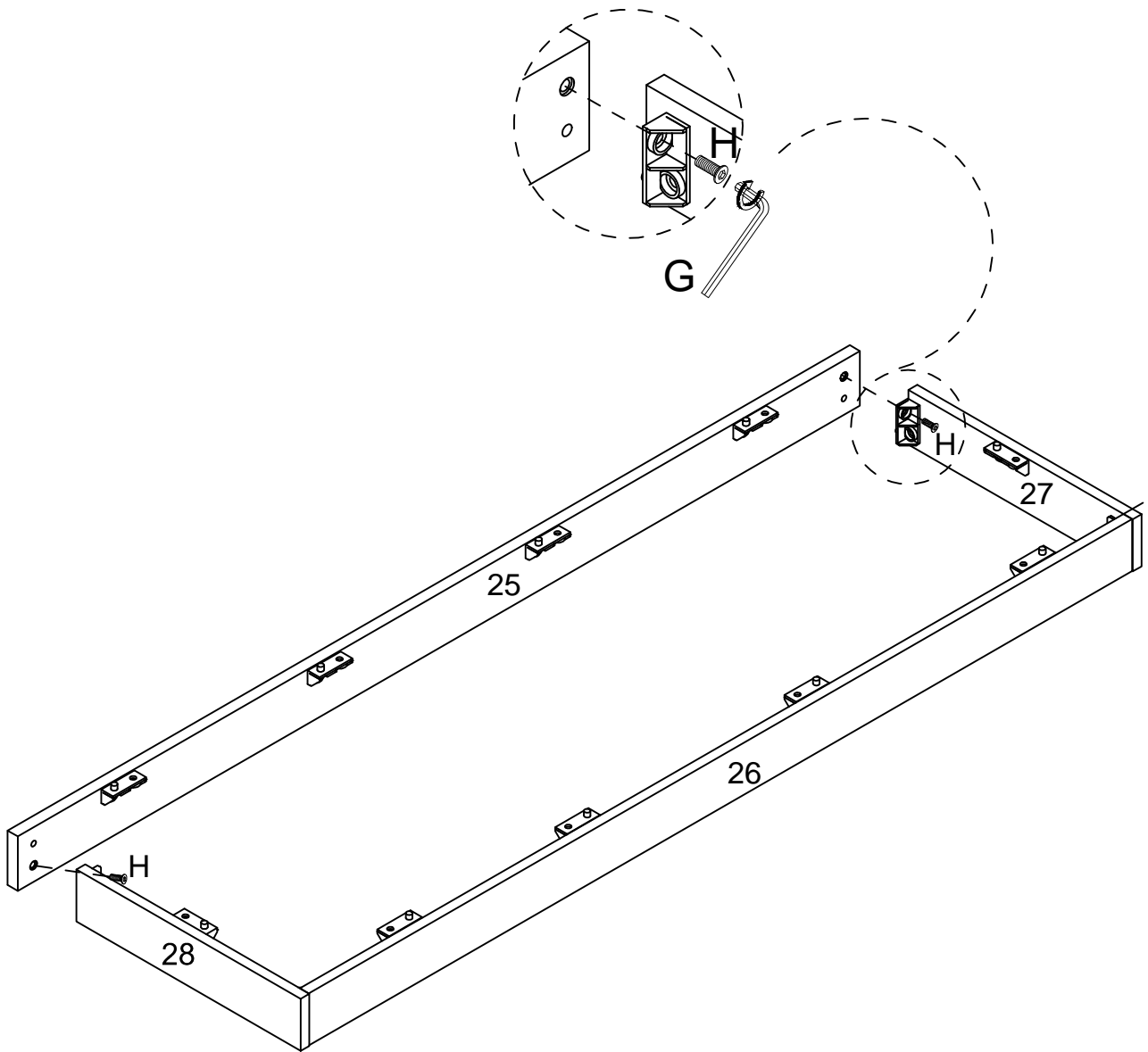

G	H
	
X1	X2

# Step 22



G	H
	
X1	X2

# Step 23

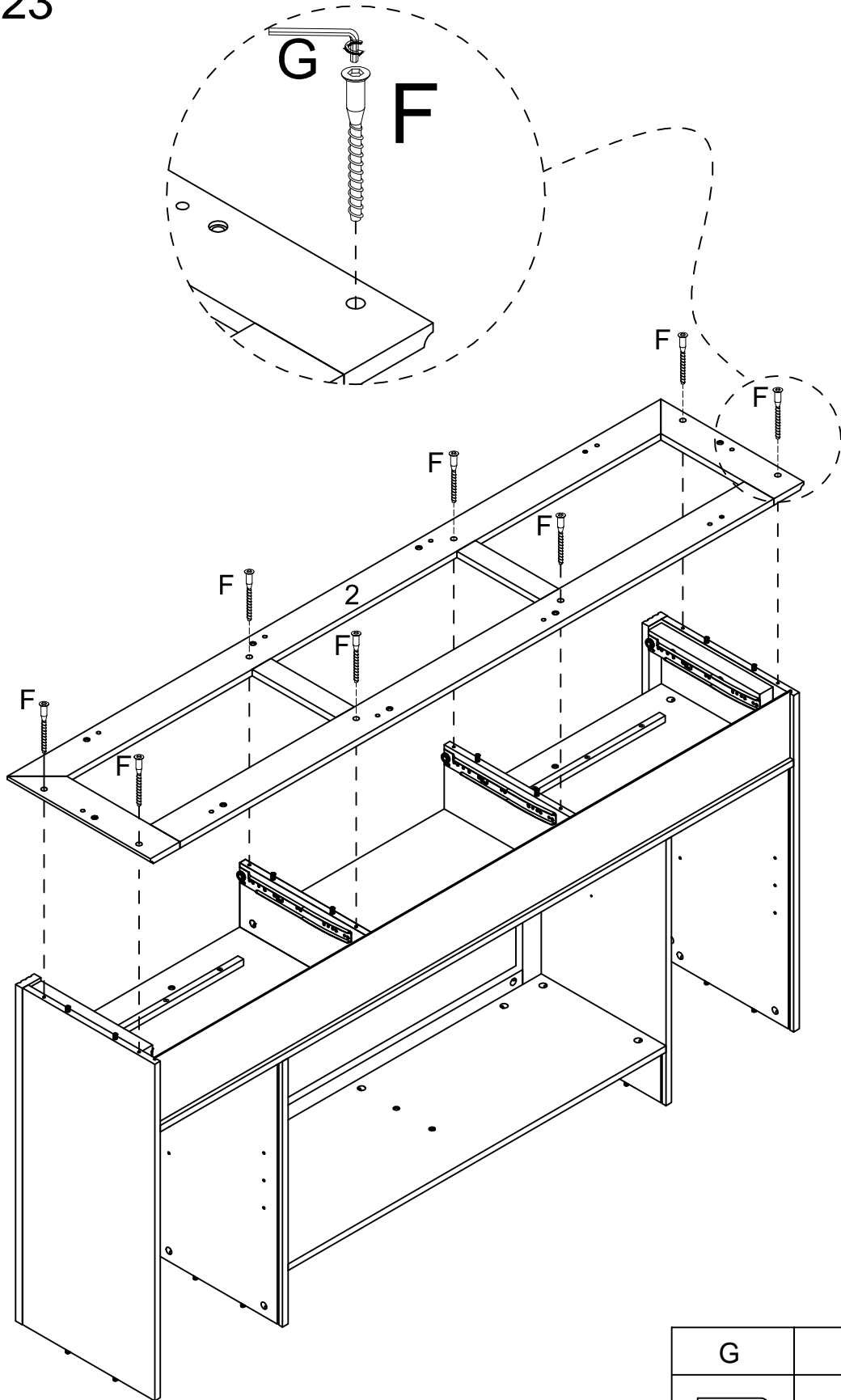

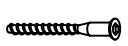
G	F
	
X1	X8

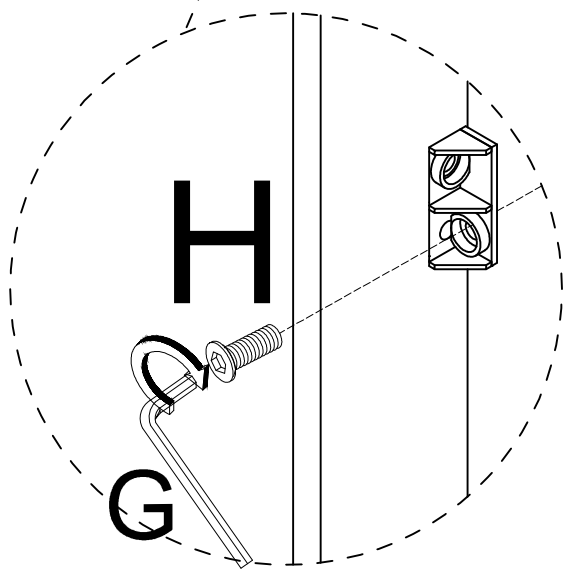
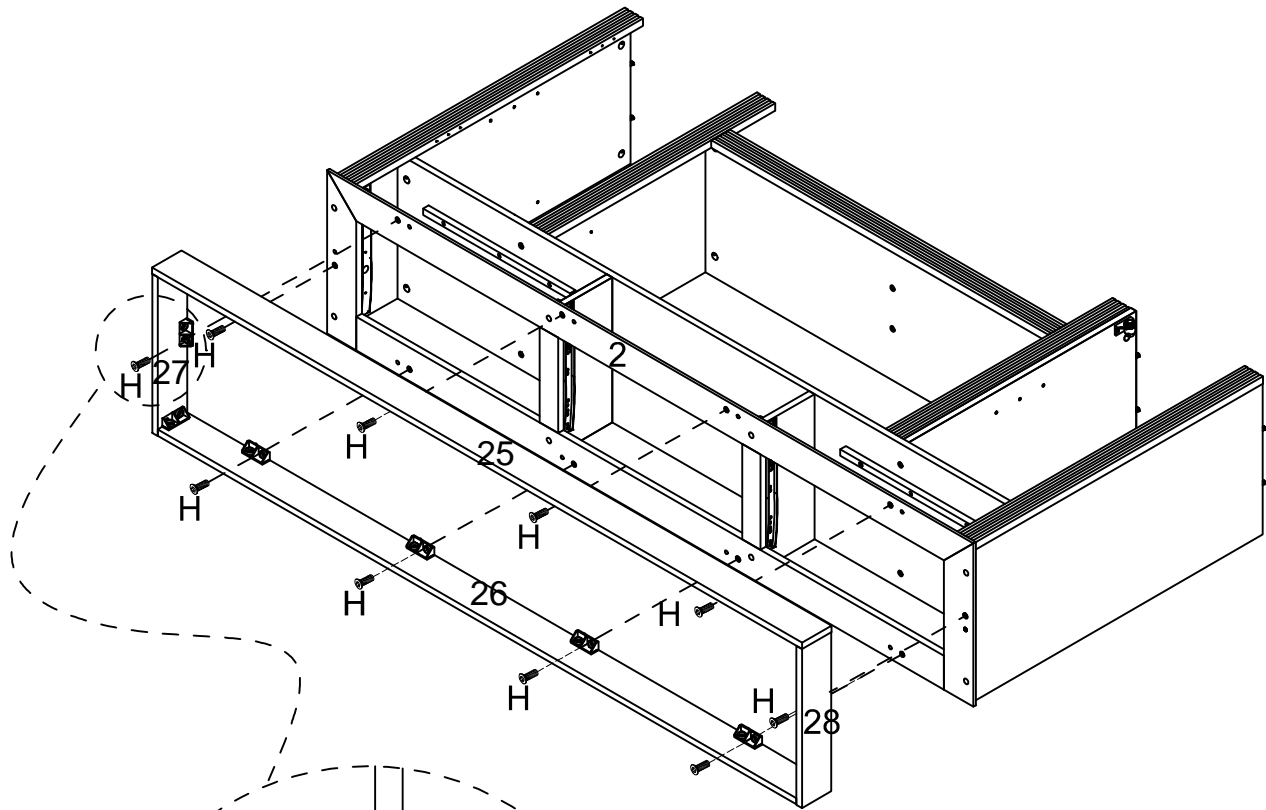

# Step 24

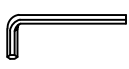

H	G
	
X10	X1

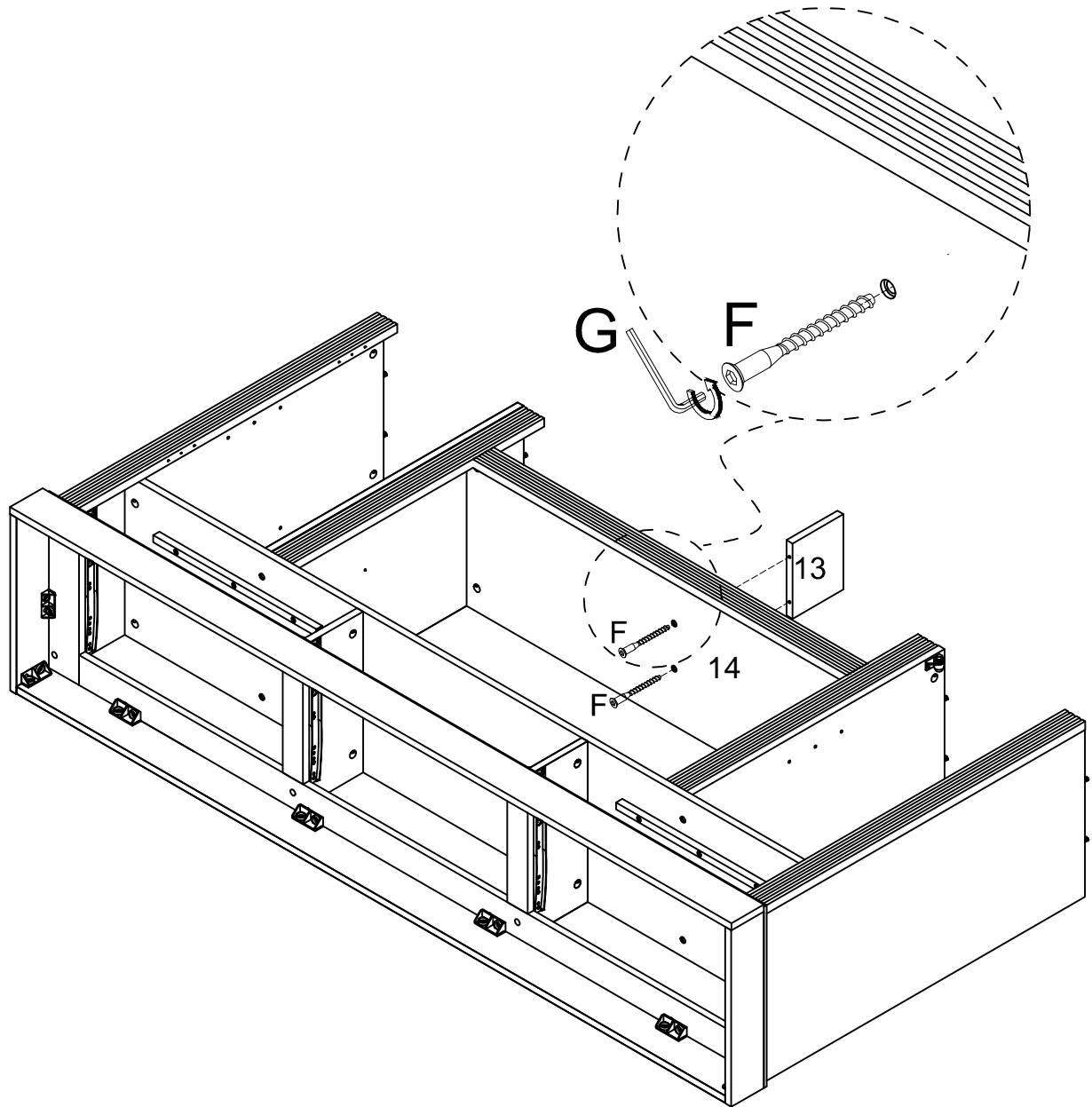
# Step 25



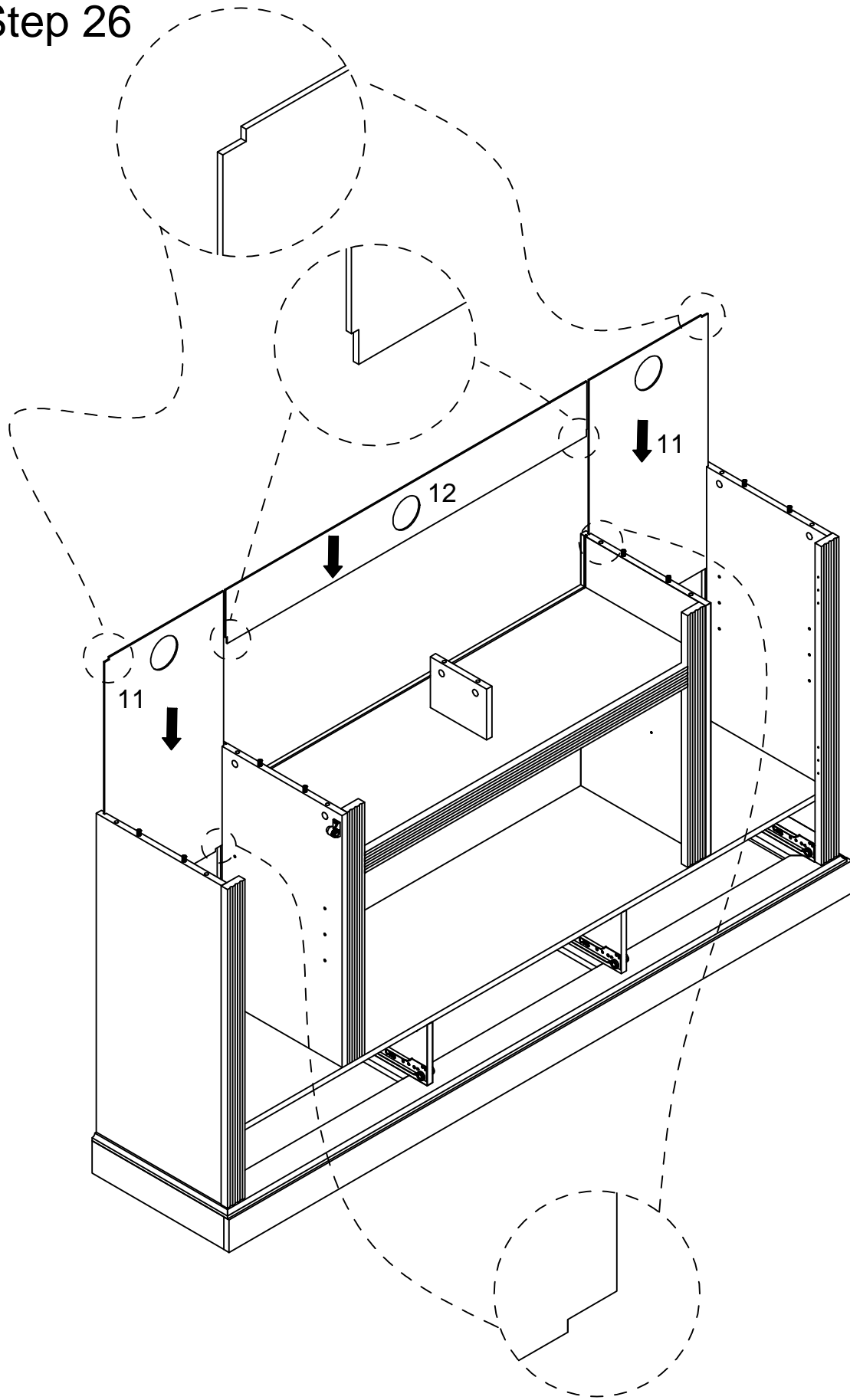

G	F
	
X1	X2

# Step 26

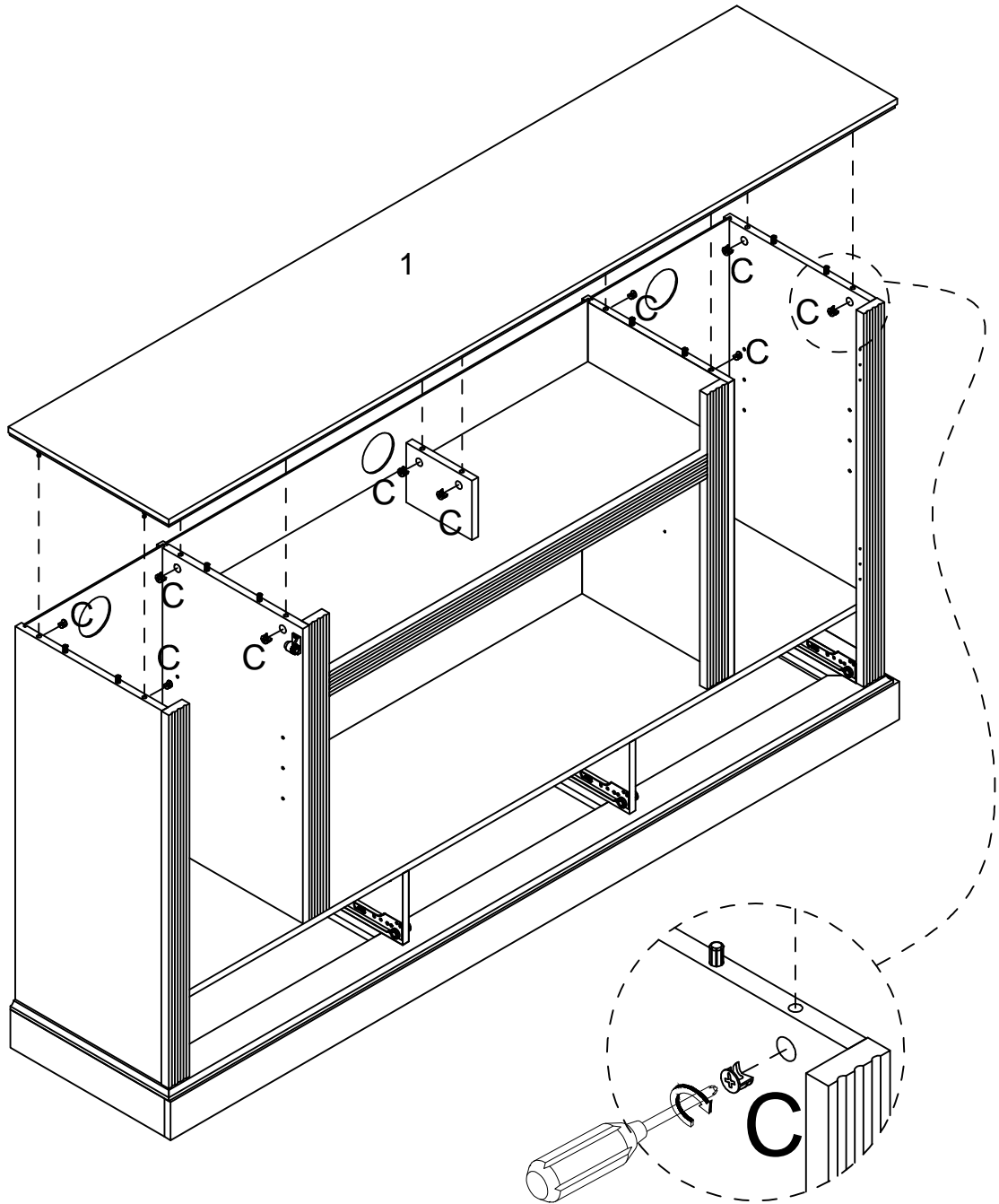
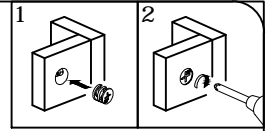

# Step 27



C

X10

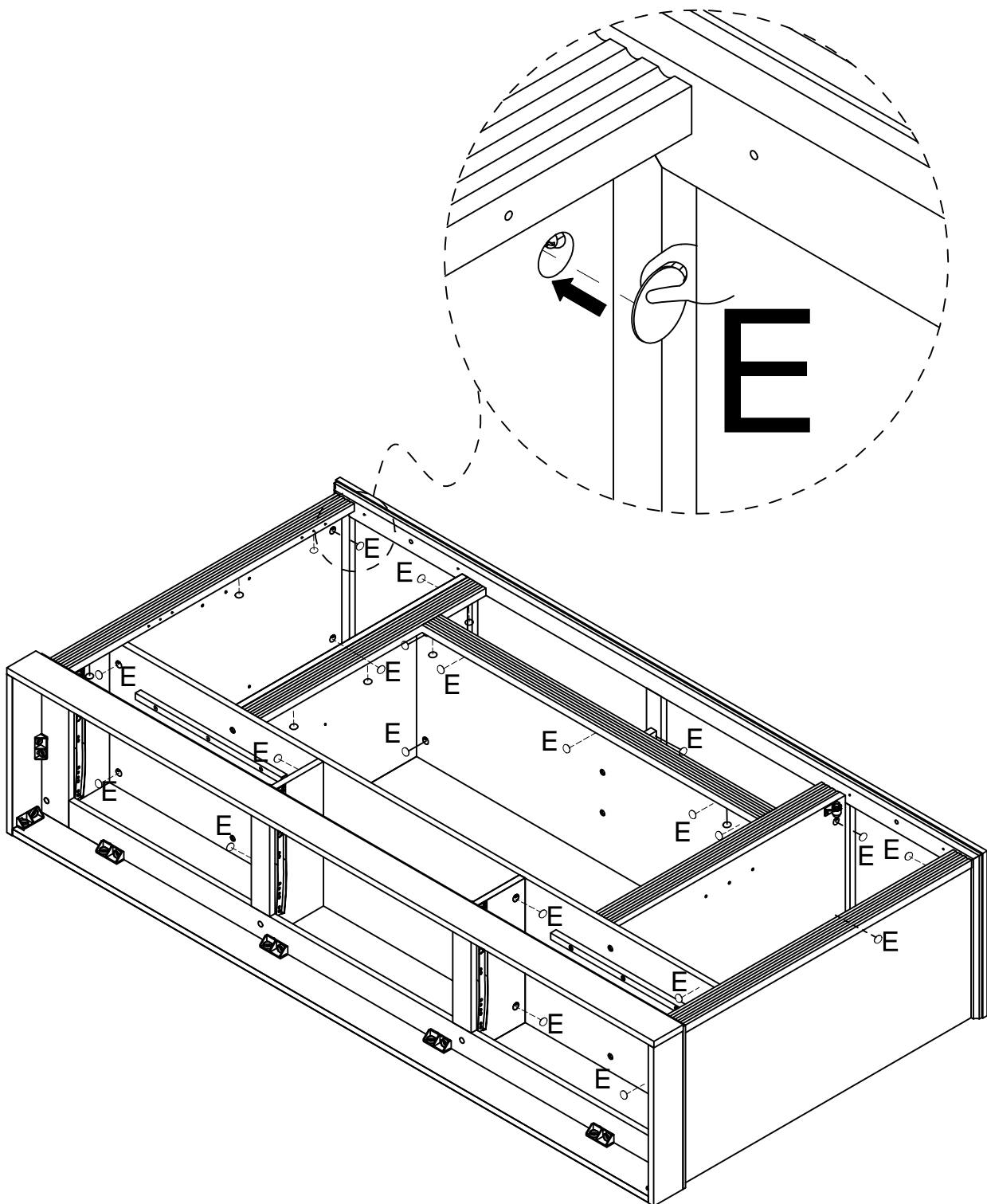
# Step 28

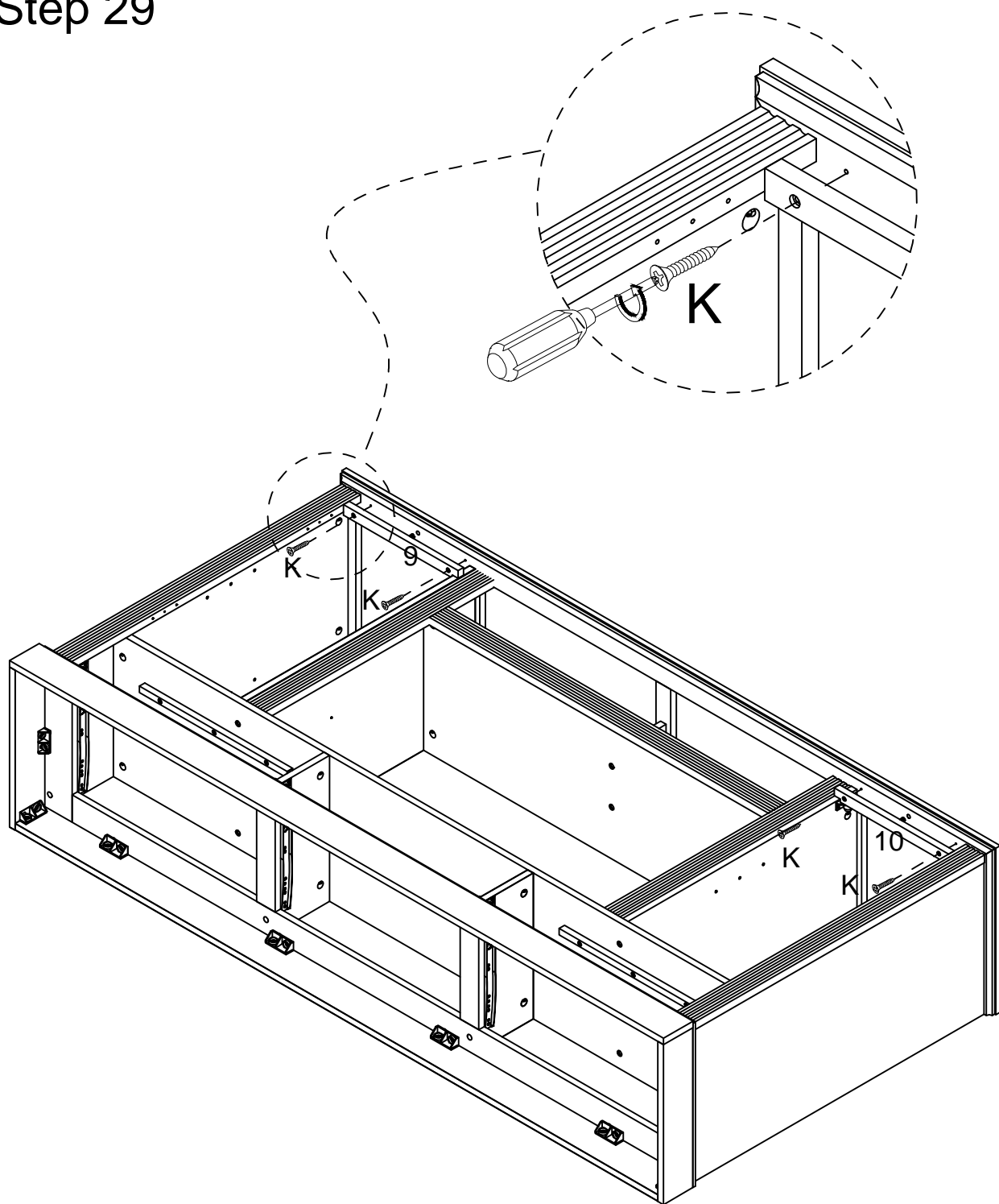

E
○
X39

# Step 29



K

X4

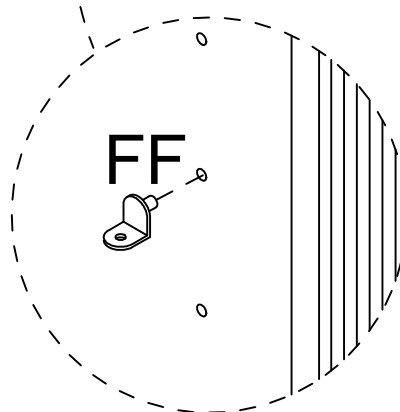
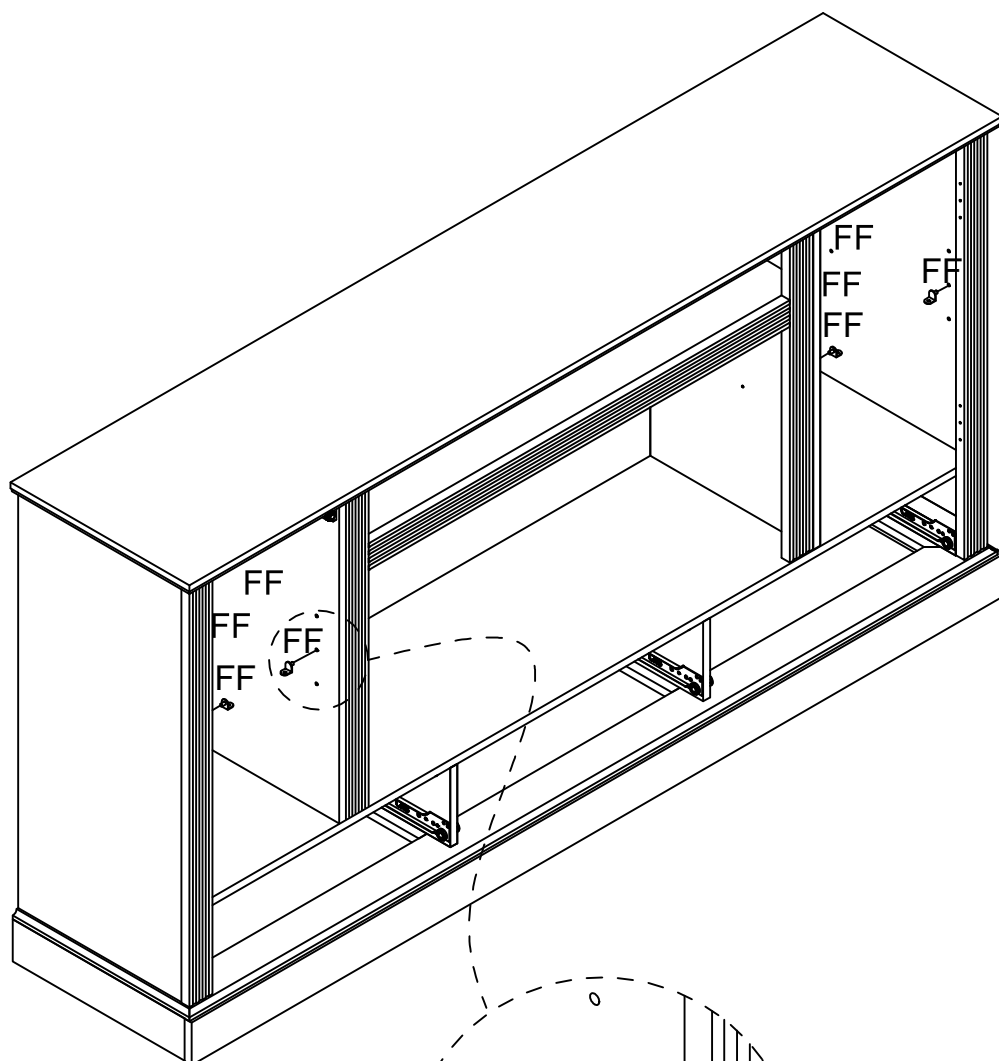
# Step 30



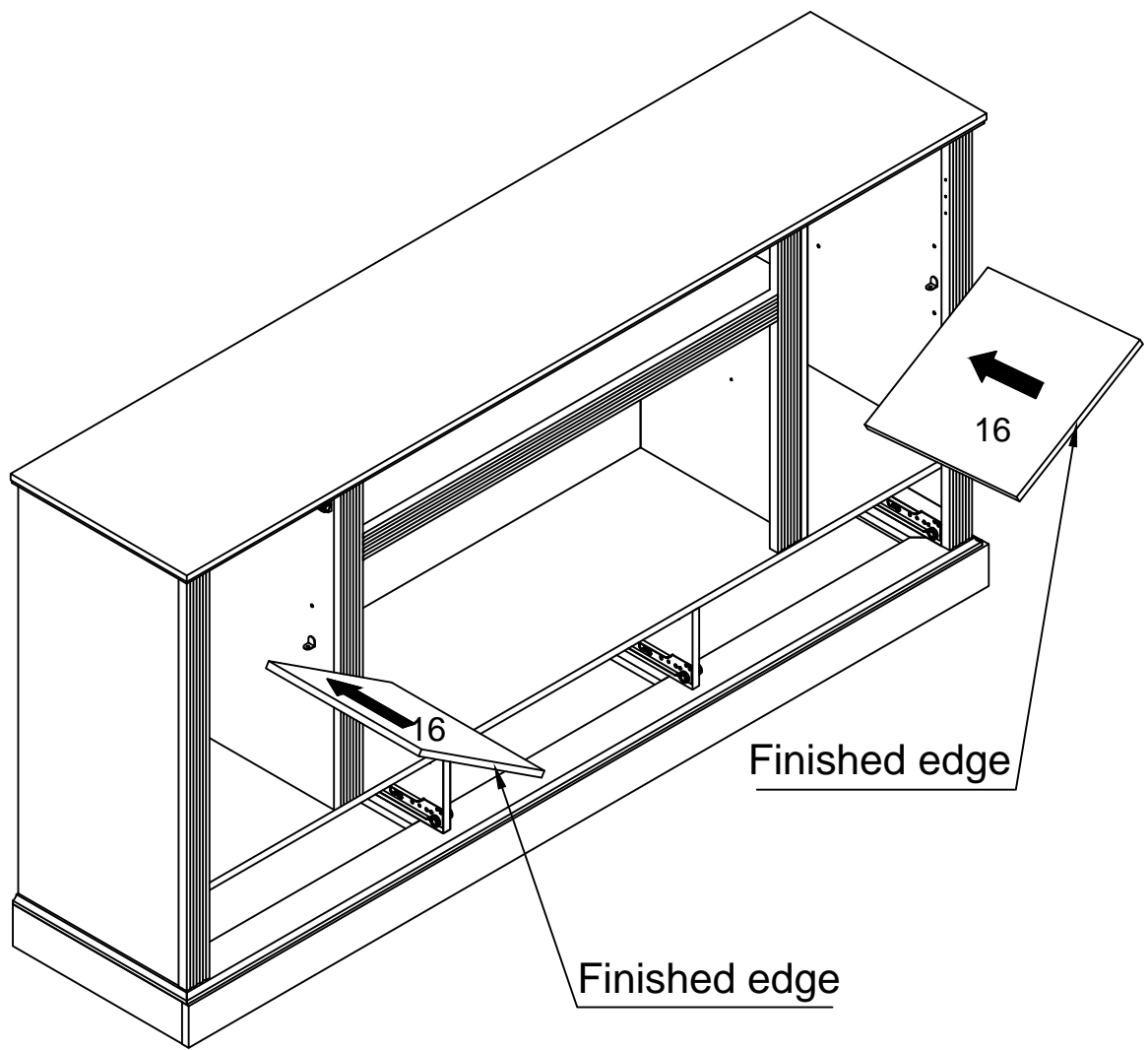

FF

X8

# Step 31

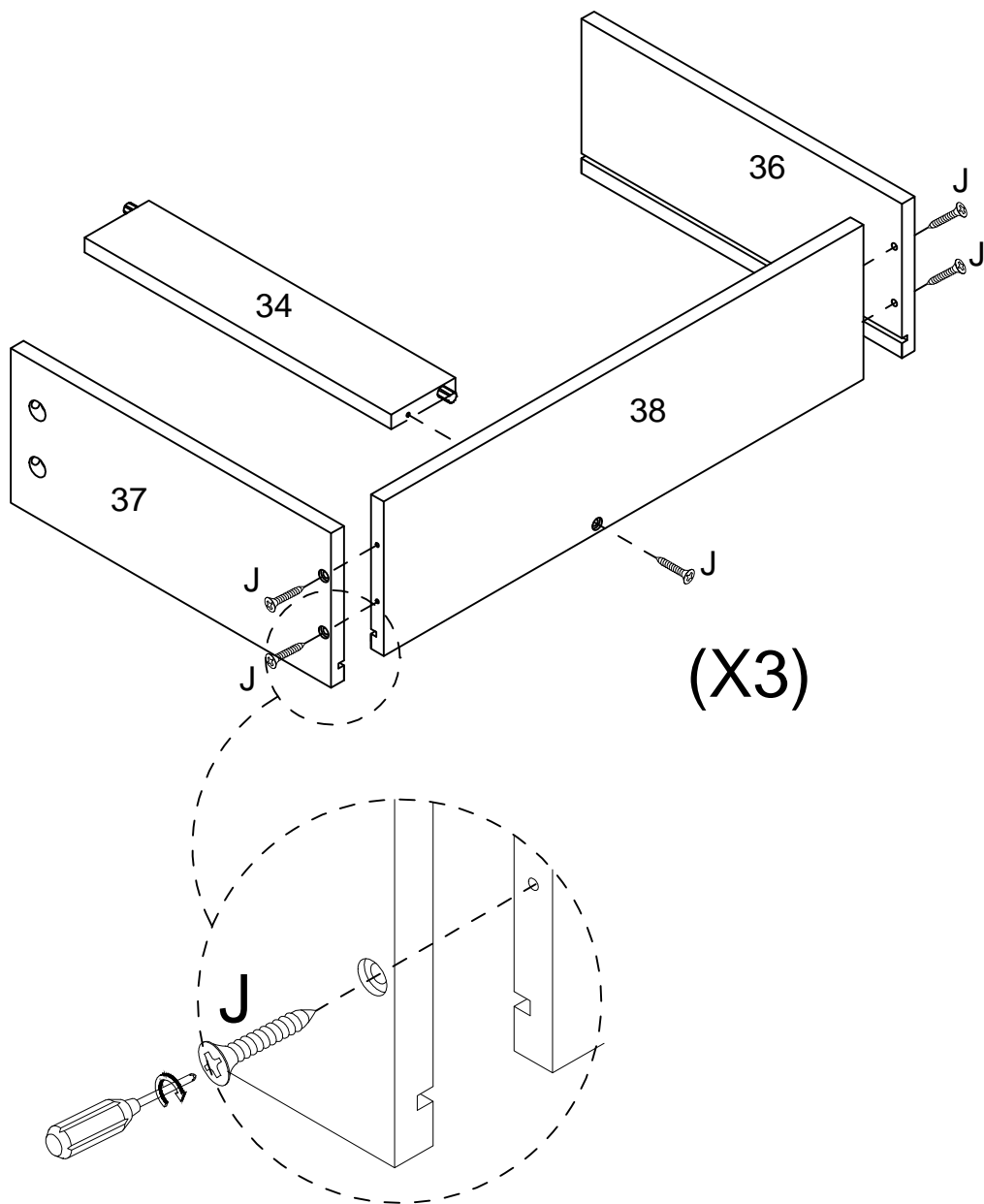

# Step 32



J

X15

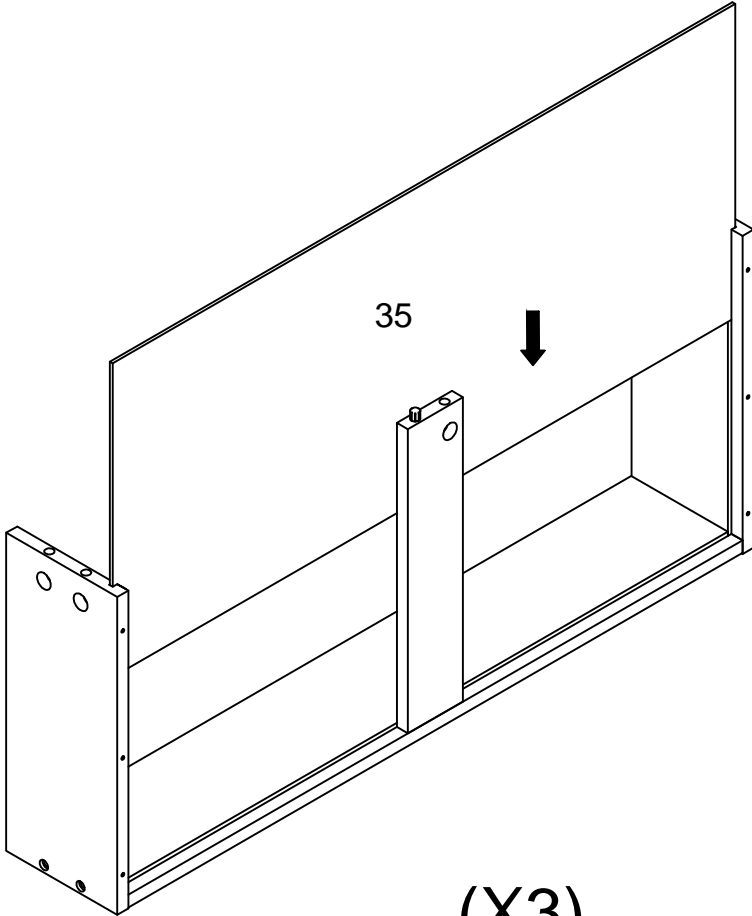
Step 33

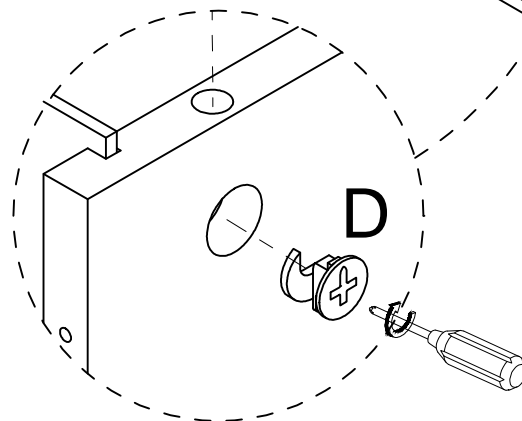
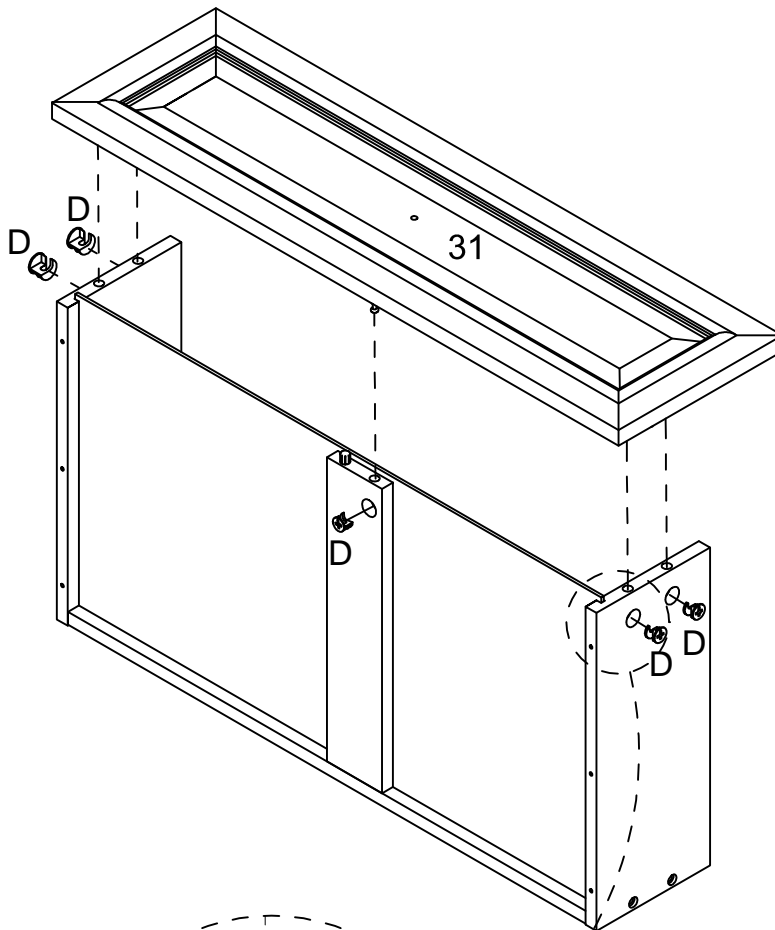
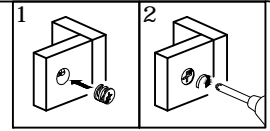

(X3)

# Step 34



D

X5

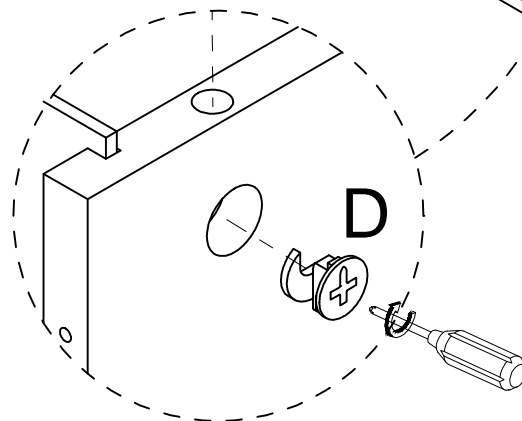
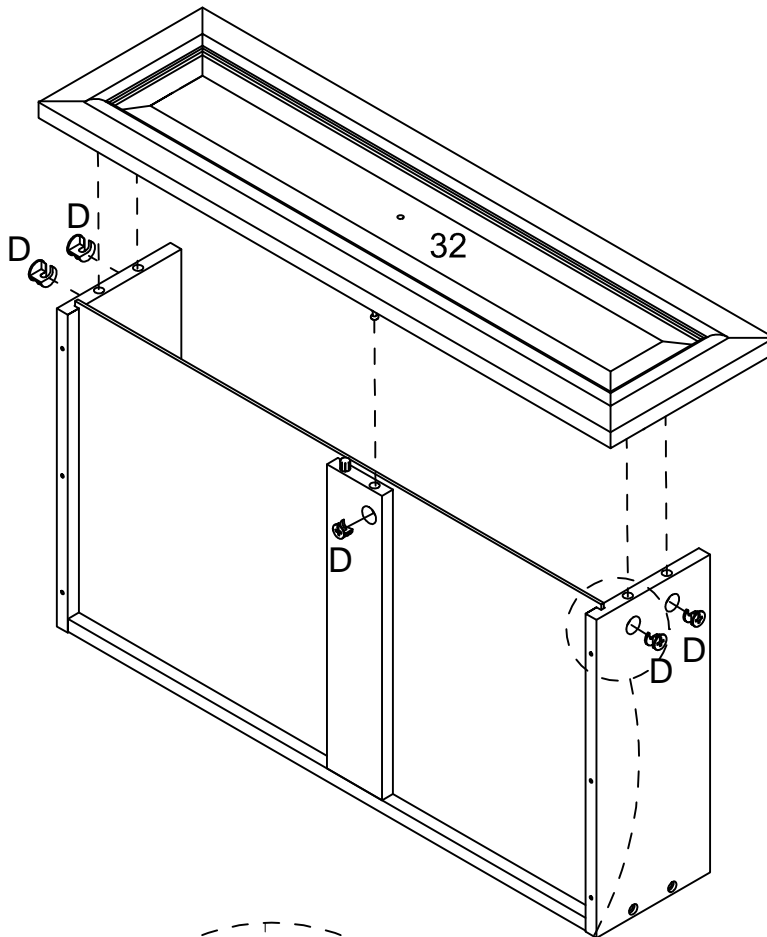
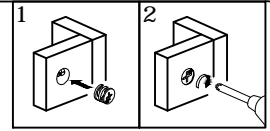
# Step 35

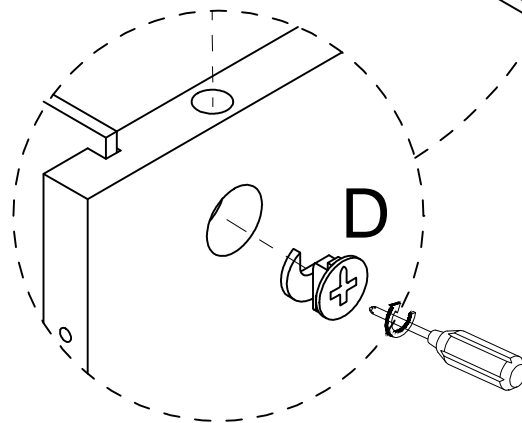
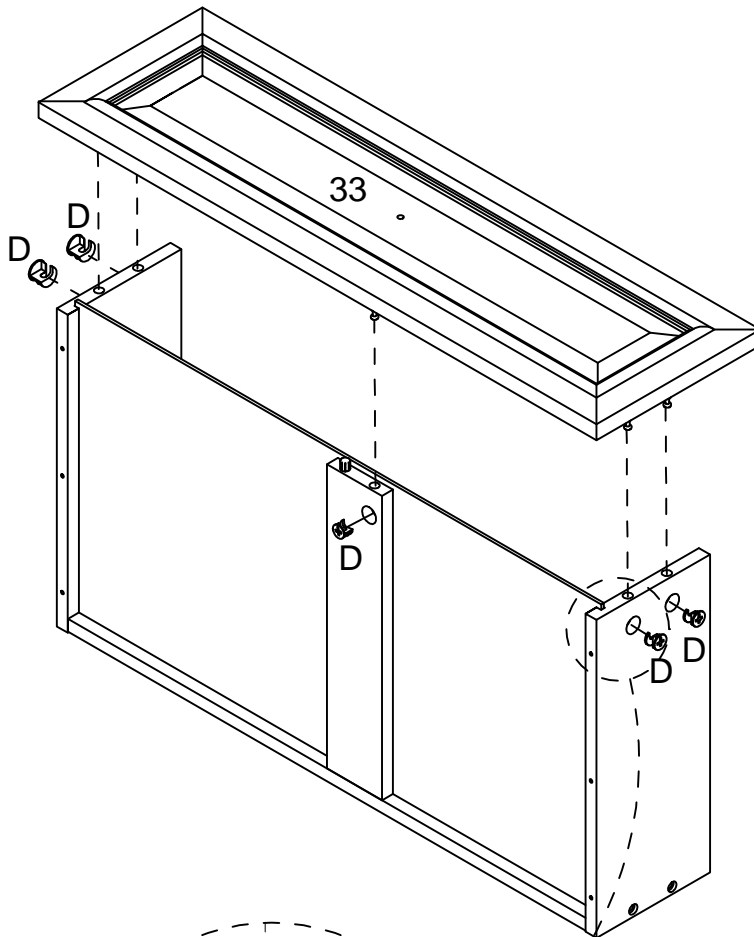
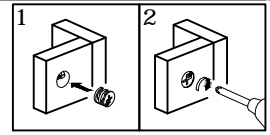

D

X5



# Step 36

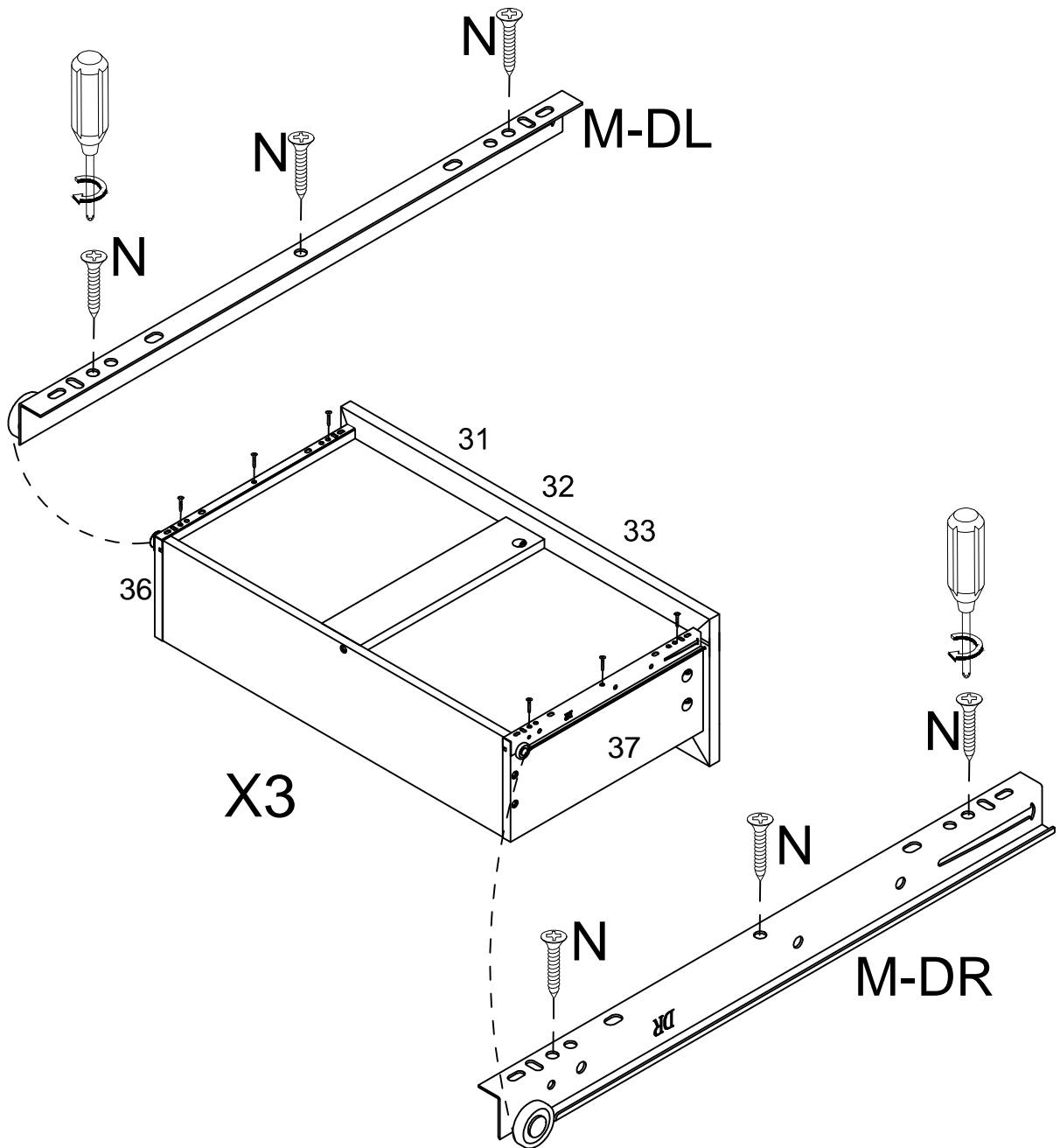

D

X5



# Step 37

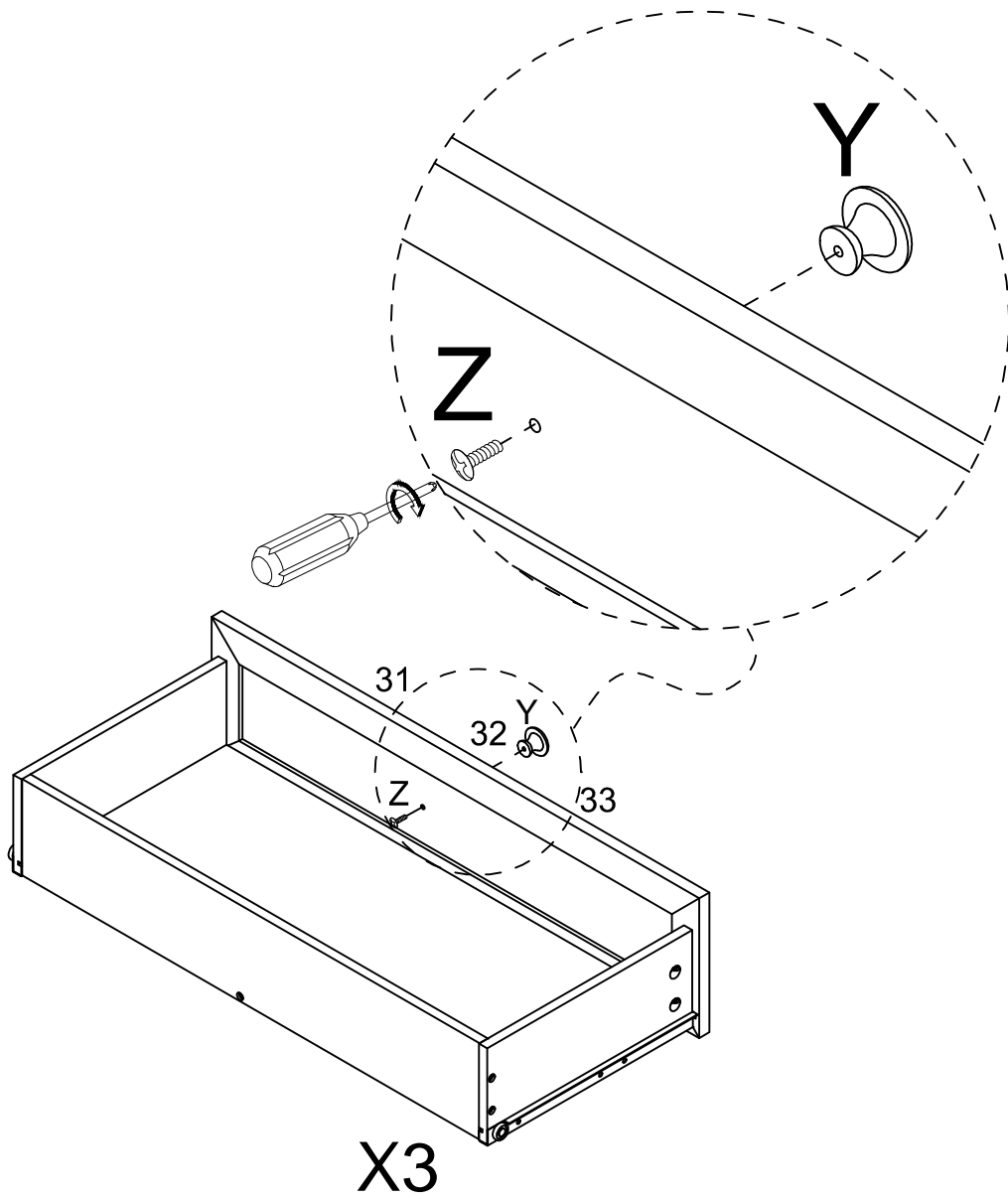

N	M
	
X18	X3

# Step 38



Z	Y
	
X3	X3

# Step 39

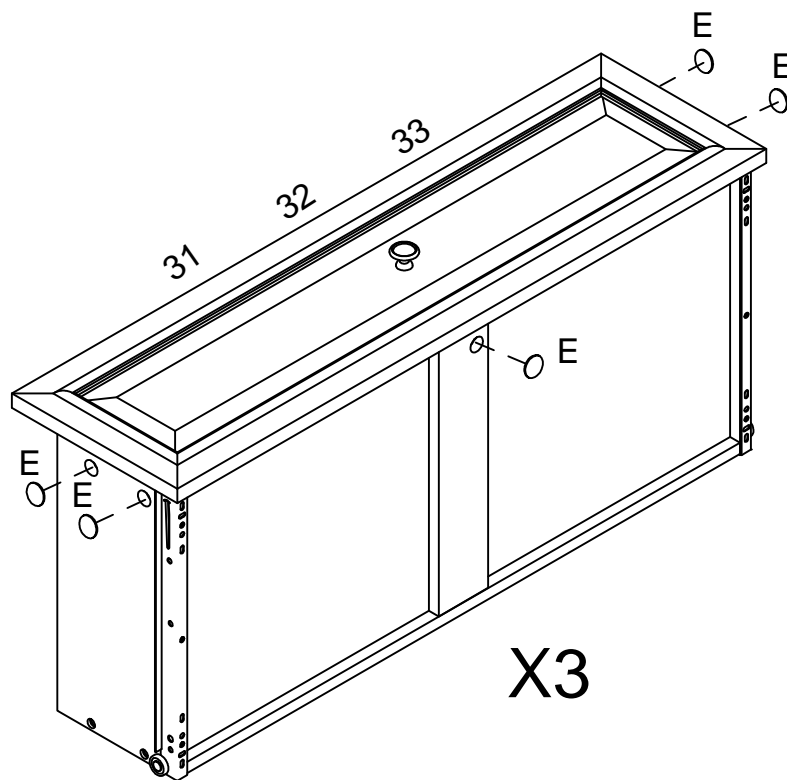



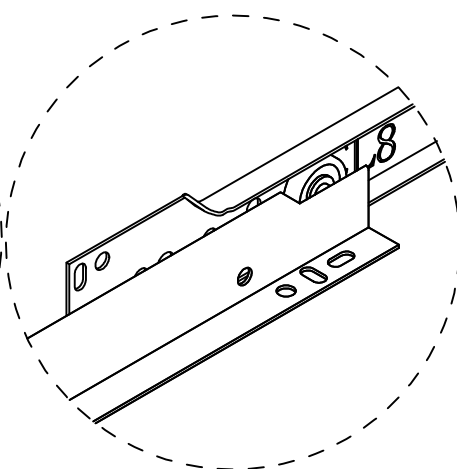
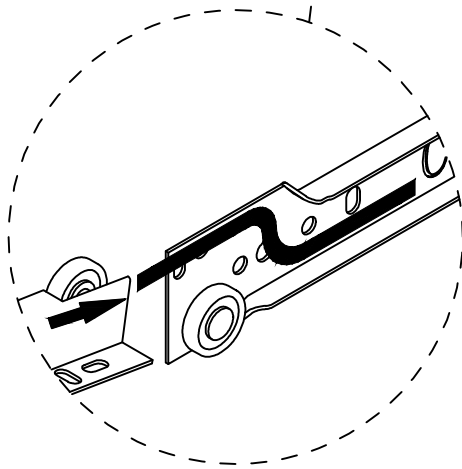
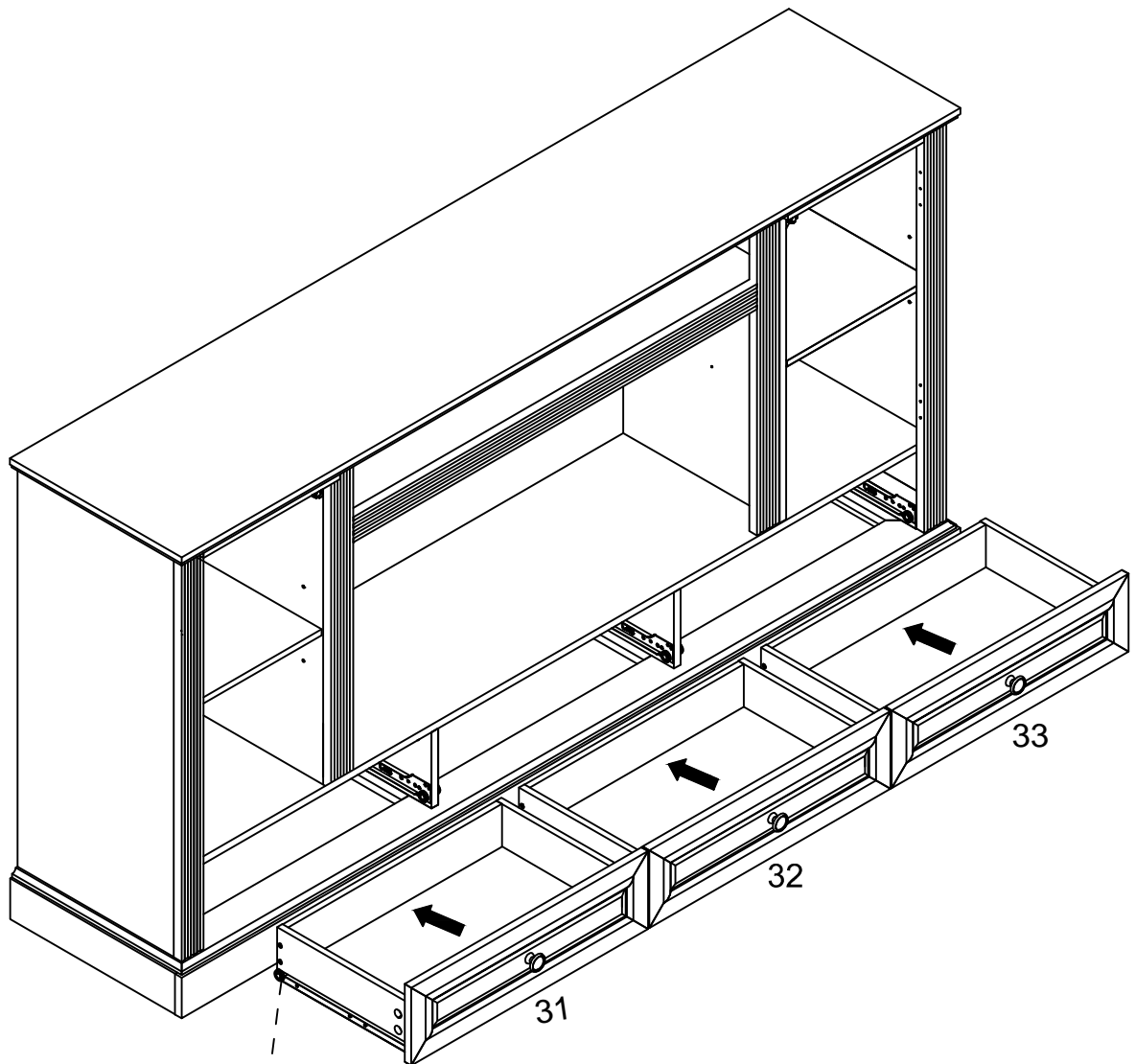

E
○
X15

# Step 40

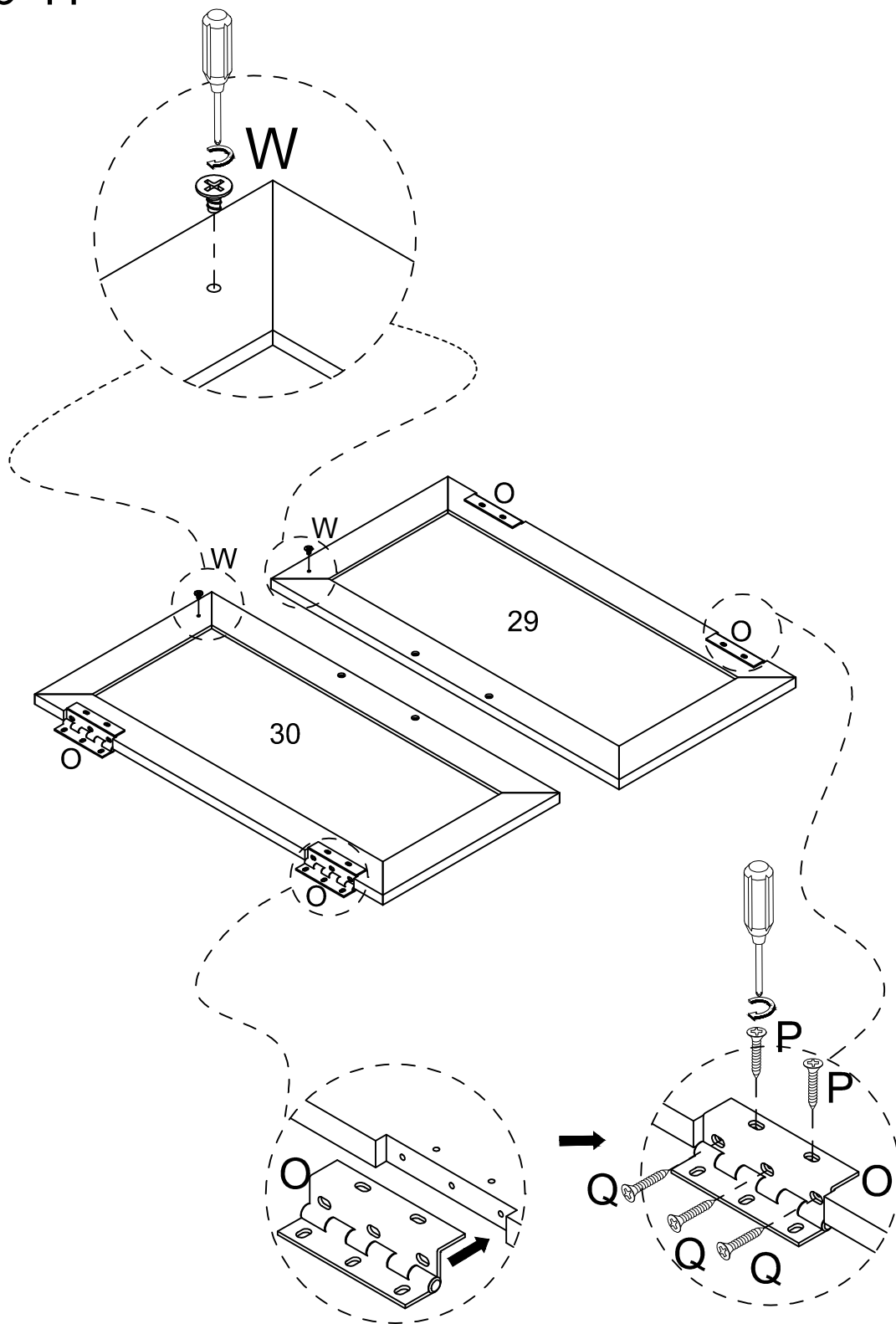



# Step 41

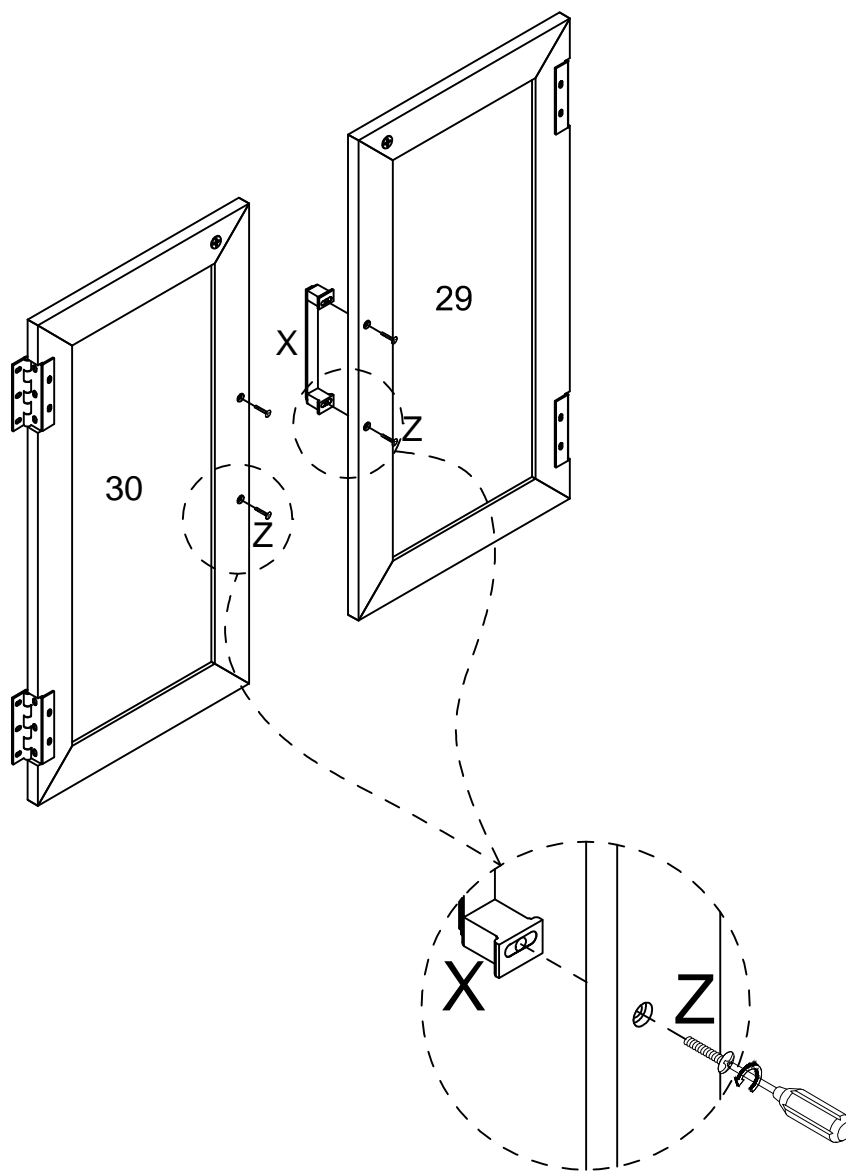

W	Q	P	O
			
X2	X12	X8	X4

# Step 42



Z	X
	
X4	X2

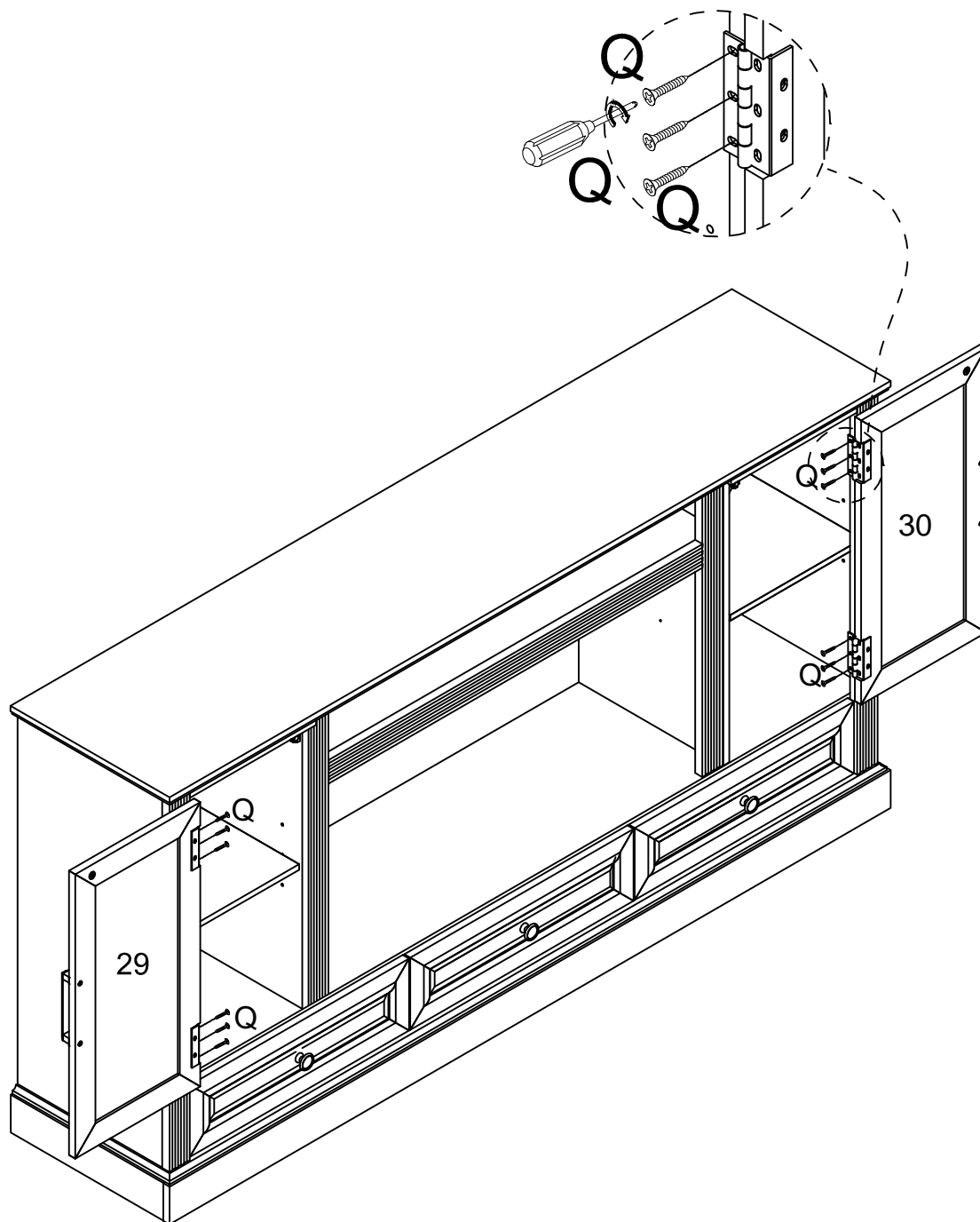

# Step 43

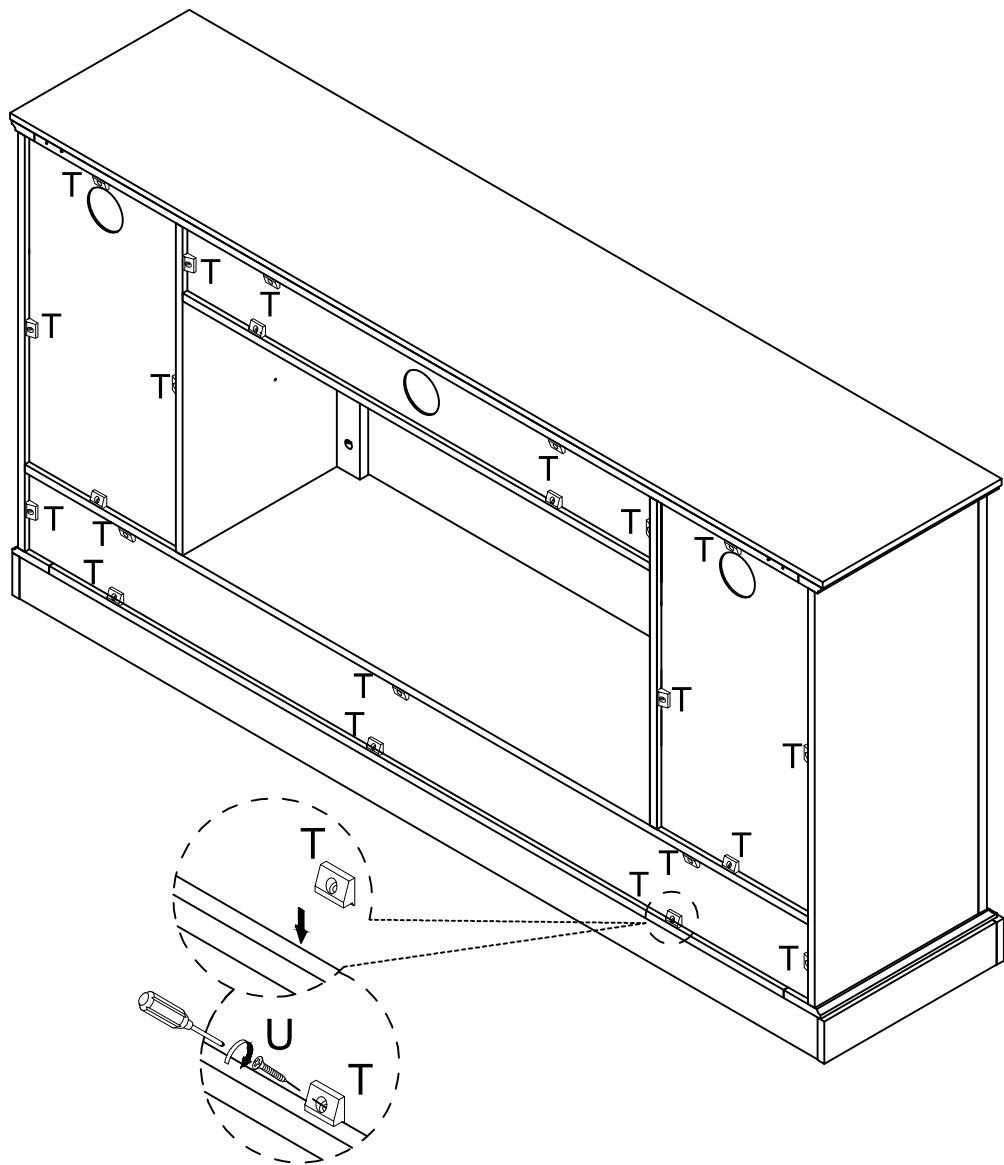

Q

X12

# Step 44

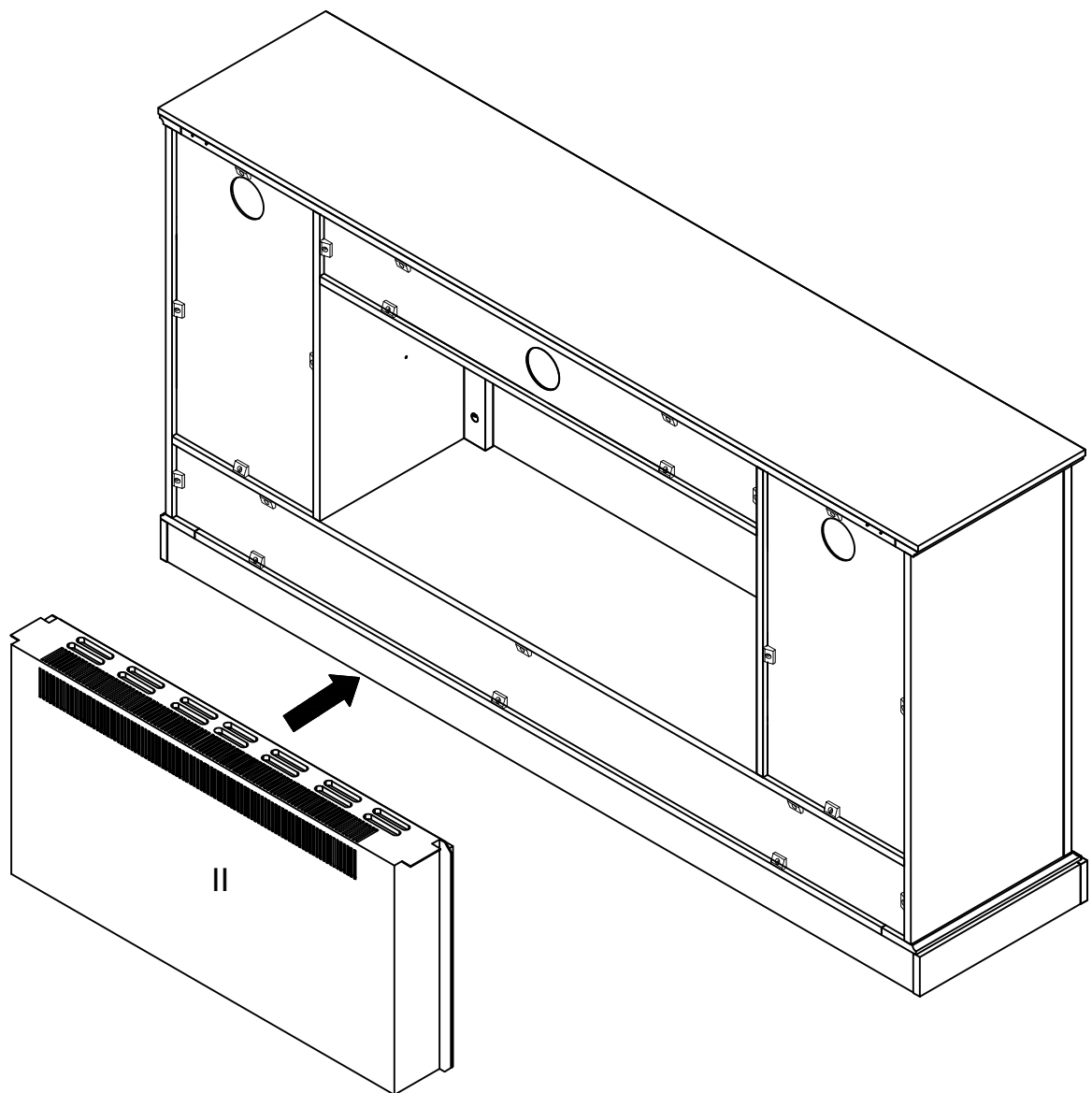

T	U
	
X22	X22

# Step 45



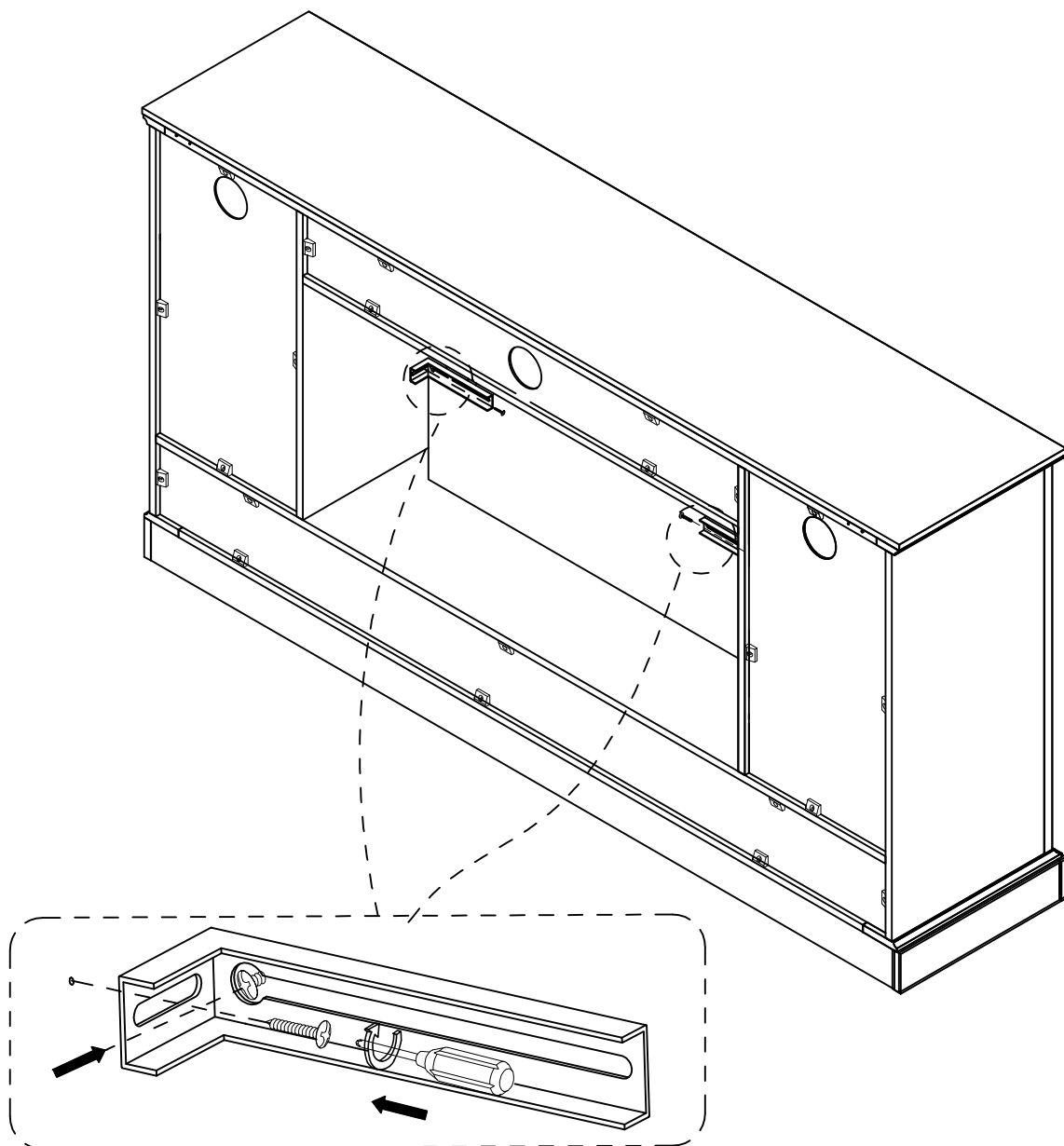

## Step 46

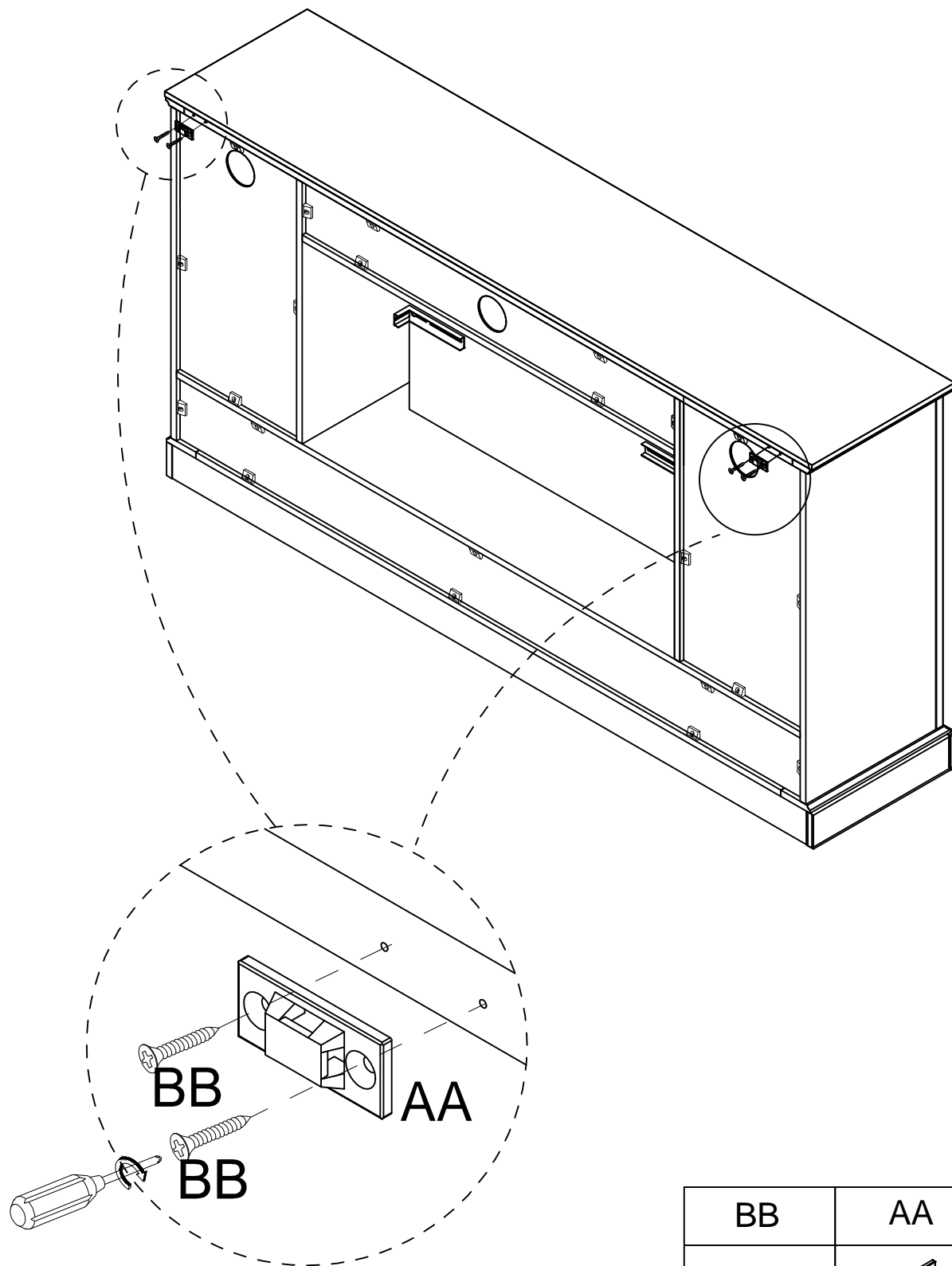

The fireplace blocking parts are in the B packing box, please refer to the fireplace installation instructions for installation steps

# Step 47



BB	AA
	
X4	X2

# Step 48

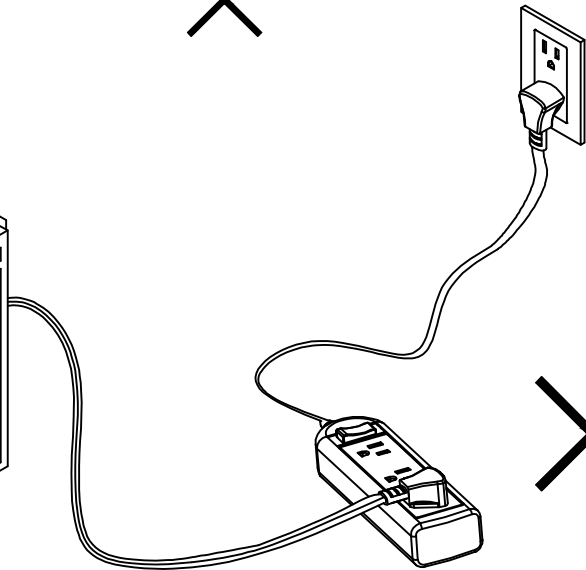
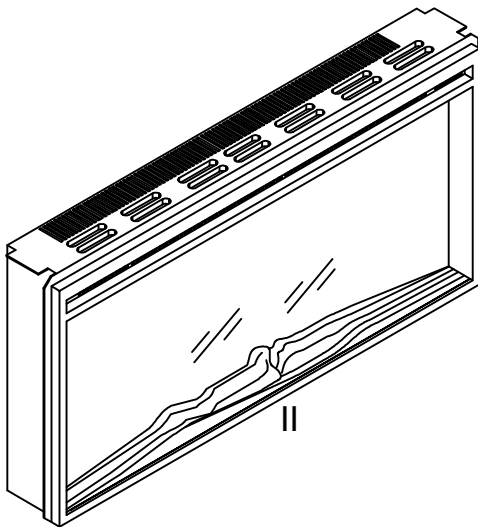
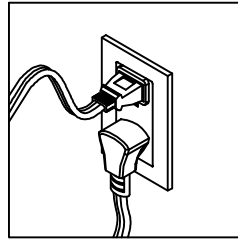
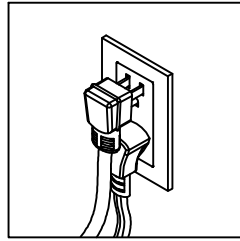
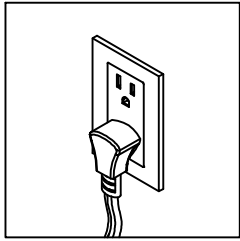

## Step 49

# Wall

Make four holes 45mm deep

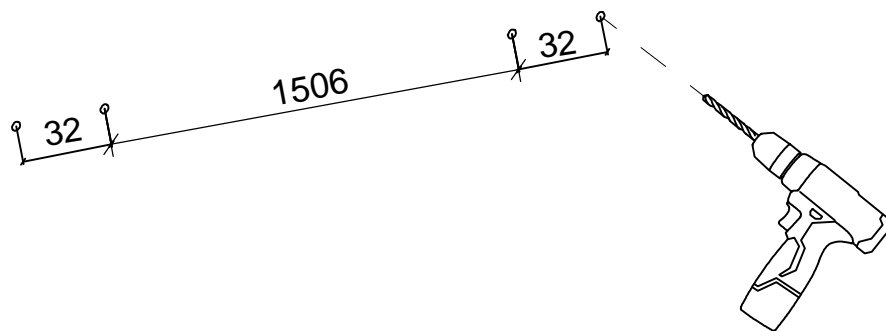

# Step 50

Wall

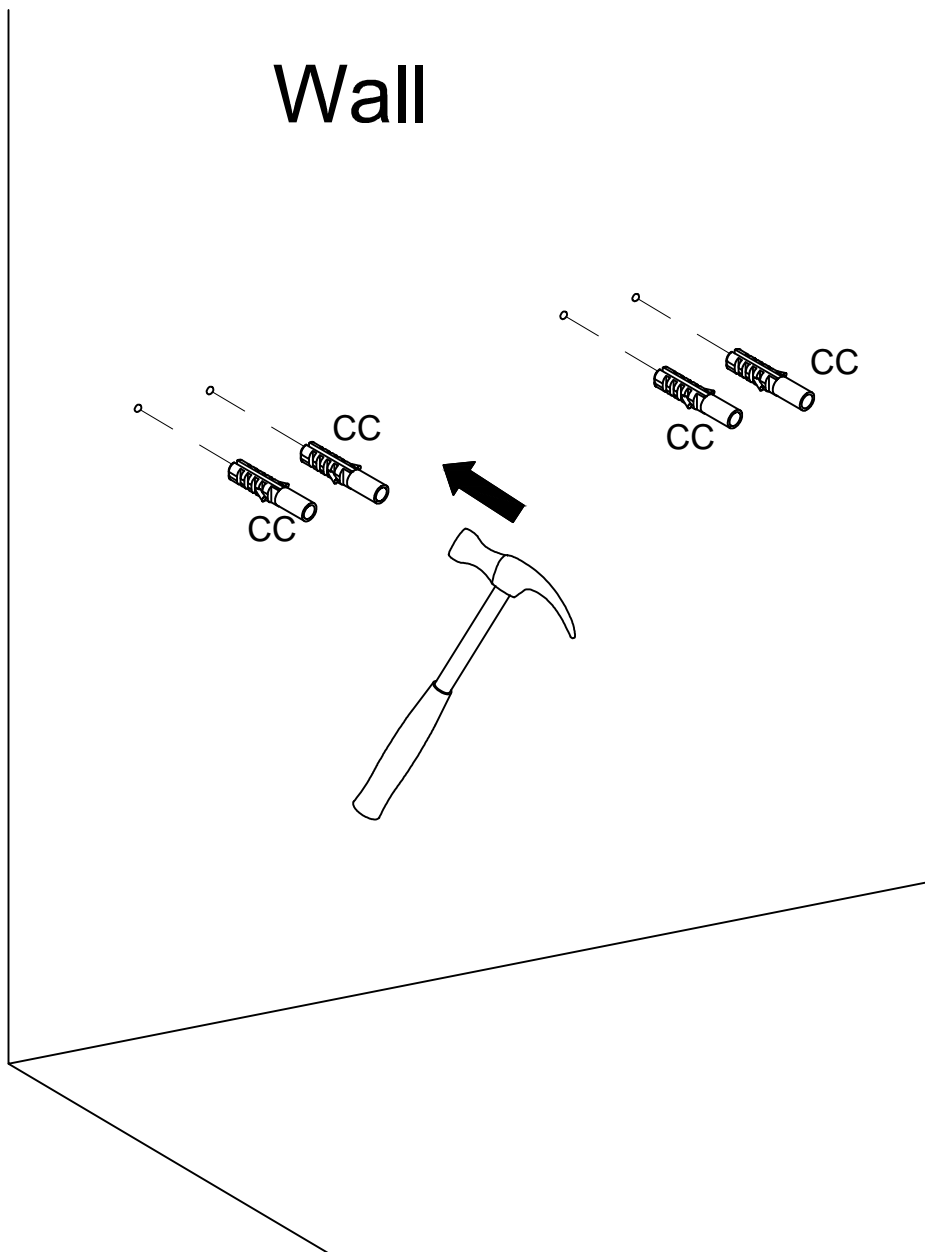



CC

X4

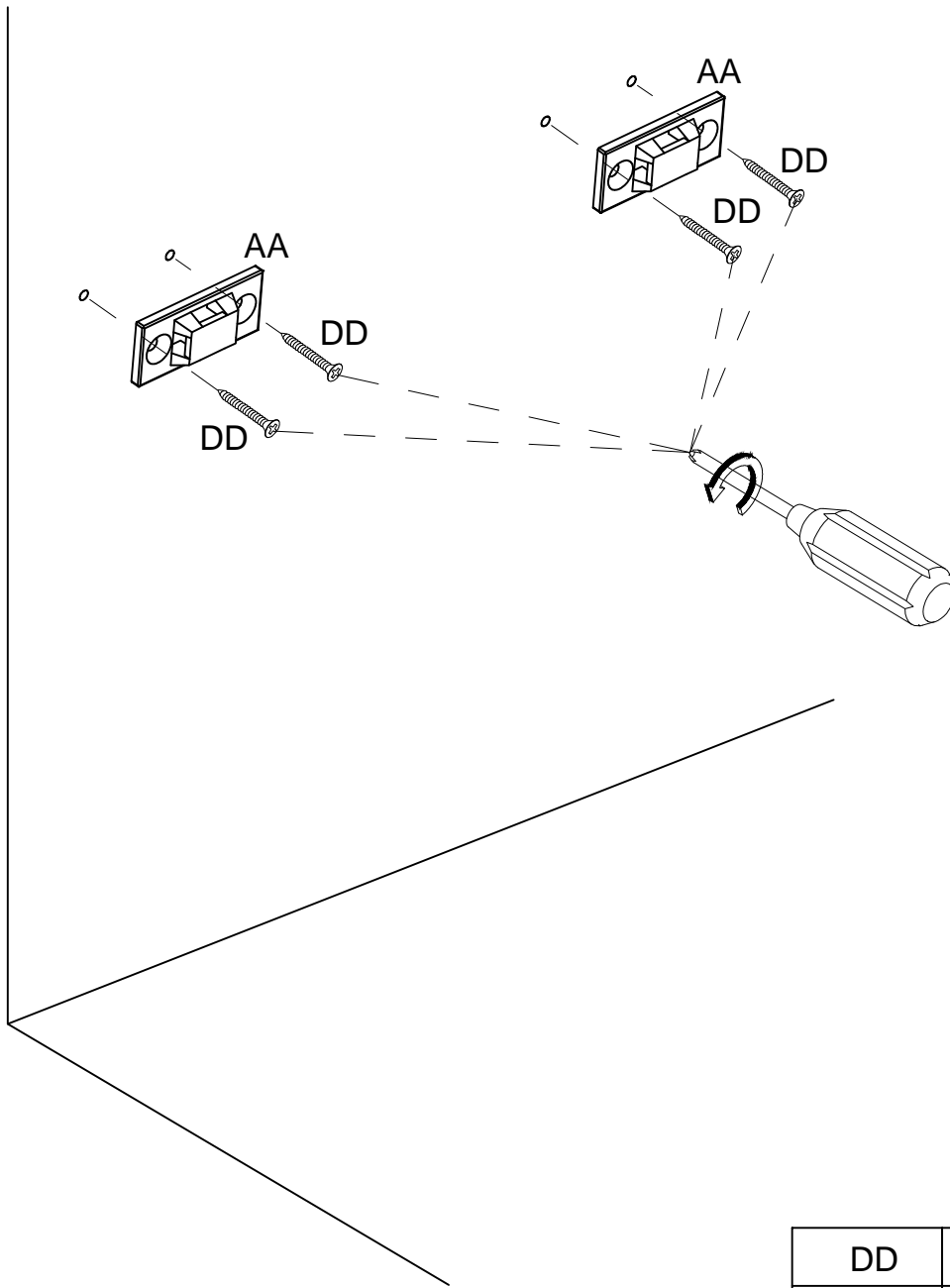
# Step 51

## Wall



DD	AA
	
X4	X2

# Step 52

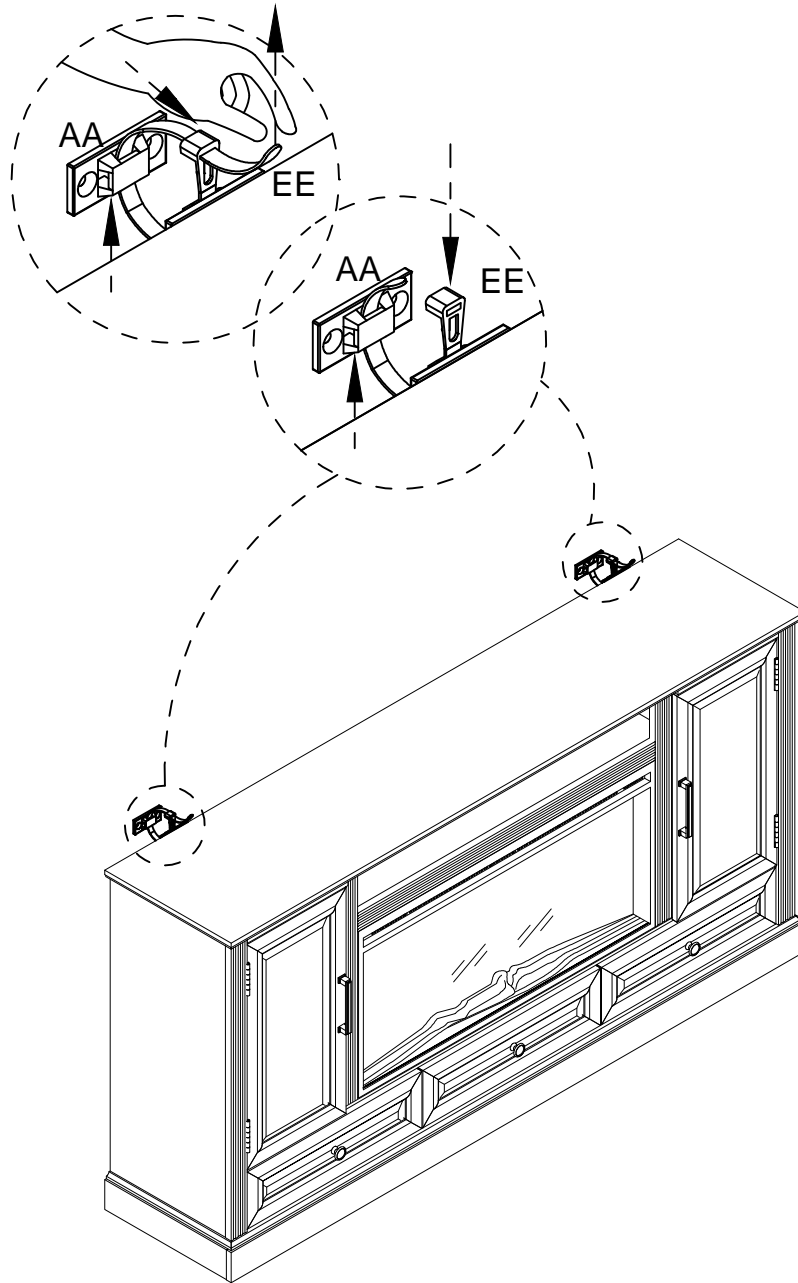

EE

X2

# Step 53

ASSEMBLY COMPLETED

