

# INSTALLATION INSTRUCTIONS

MANUFACTURING QUALITY  
CEILING FANS SINCE FOREVER.

# Live Smarter

This Smart Ceiling Fan is :



ETL certified &  
damp-rated, suitable  
for indoor/covered  
-outdoor use



DC Motor  
10-speed, ultra-quiet,  
reversible &  
energy efficient



Connect via Wi-Fi  
or Bluetooth for  
advanced control

Compatible with  
smart devices

# Important: Please read and save these instructions before installation

## Basic Product Specifications

		Voltage	120V
Fan Blade Span	52"	Rated Wattage	48W (Fan 26W / Lamp 22W)
Gross Weight	15.4 lbs.	Motor RPM	50-215 RPM
Maximum Airflow	4500 CFM	Maximum Noise	58 dB(A)
		Voltage	120V
Fan Blade Span	52"	Rated Wattage	48W (Fan 26W / Lamp 22W)
Gross Weight	15.5 lbs.	Motor RPM	50-205 RPM
Maximum Airflow	4400 CFM	Maximum Noise	58 dB(A)

# Live Smarter

This Smart Ceiling Fan is :



ETL certified &  
damp-rated, suitable  
for indoor/covered  
-outdoor use

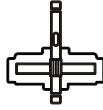

DC Motor  
variable speed,  
ultra-quiet,  
reversible & energy  
efficient



Connect via Wi-Fi  
or Bluetooth for  
advanced control



Compatible with  
smart devices

# SAFETY PRECAUTIONS

---

## READ AND SAVE THESE INSTRUCTIONS

- Before you begin installing the fan, shut power off at the circuit breaker of the fuse box.
- Make sure that all electrical connections are in accordance with National Electrical Code, ANSI/NFPA 70 and local codes. Hire a licensed electrician if you are unfamiliar with installing electrical wiring.
- Make sure the installation site you choose allows the fan blades to rotate without any obstructions. Allow a minimum clearance of 2.1m (7 feet) from the floor and 18 inches from the tip of the blades to the wall.
- The outlet box and support structure must be securely mounted and capable of reliably supporting a minimum of 35 pounds. Use only U.L. listed outlet boxes marked "Acceptable for Fan Support of 15.9 kg (35 lbs) or less".
- Before and after you install the fan, make sure that all mounting components are secured to prevent the fan from falling.
- Do not insert anything into the fan blades while the fan is operating.
- To change the direction of the rotation of the blades, the fan must be in operation mode.
- All screws must be checked and retightened where necessary before installation.
- After making the wire connections, the wires should be spread apart with the grounded conductor and the equipment-grounding conductor on one side of the outlet box and the ungrounded conductor on the other side of the outlet box.
- The splices after being made should be turned upward and pushed carefully up into the outlet box. Conductor wiring identified as grounded is to be connected to a grounded conductor of power supply. Conductor wiring identified as ungrounded conductor is to be connected to an ungrounded conductor. Conductor wiring identified for equipment grounding is to be connected to an equipment- grounding conductor.
- This device complies with part 15 of the FCC Rules. Operation is subject to the following two conditions: (1) This device may not cause harmful interference, and (2) this device must accept any interference received, including interference that may cause undesired operation.
- This product is suitable for use in damp locations.

# SAFETY PRECAUTIONS

---

- **CAUTION:** Read all instructions and safety information before installing your new fan. Review accompanying assembly diagrams.
- **WARNING:** Mount only to an outlet box marked acceptable for fan support.  
**AVERTISSEMENT:** Assembler uniquement à une boîte de sortie jugée acceptable pour retenir un ventilateur.
- **WARNING:** To reduce the risk of fire, electric shock, or personal injury, mount to a structural framing member or to an outlet box marked acceptable for fan support of 15.9 kg (35 lbs) or less. For outlet box mounting, use mounting screws provided with the outlet box.  
**AVERTISSEMENT:** Afin de réduire les risques d'incendie, de choc électrique ou de blessures corporelles, ils doivent être montés sur des éléments de charpente structurale ou sur des boîtes de sortie marquées d'un support de ventilateur acceptable de 15,9 kg (35 LB) ou moins. Pour l'installation de la boîte de sortie, utilisez les vis de montage fournies avec la boîte de sortie”
- **CAUTION:** To reduce the risk of injury, use only the screws provided with the outlet box in conjunction with the lock washers.
- **WARNING:** To reduce the risk of personal injury, do not bend the blade bracket when installing the brackets, balancing the blades, or cleaning the fan. Do not insert foreign objects in between rotating fan blades.
- **CAUTION:** To reduce the risk of electric shock, disconnect the electrical supply circuit to the fan before installing the light kit.
- **WARNING:** To reduce the risk of fire or electric shock, this fan must be installed with a general use, non-dimmable, single gang, isolating wall control/switch.
- **WARNING:** To reduce the risk of fire or electric shock, do not use this fan with any solid-state speed control device.  
**AVERTISSEMENT:** Ne convient pas à des régulateurs de vitesse à semi-conducteurs.
- **NOTE:** The important safeguards and instructions appearing in this manual are not meant to cover all possible conditions and situations that may occur. It must be understood that common sense, caution and care are factors which cannot be built into this product. These factors must be supplied by the person(s) installing, caring for and operating the unit.
- **CAUTION:** The light source is designed for this specific application and can overheat if serviced by untrained personnel. If any servicing is required, the product should be returned to an authorized service facility for examination or repair.
- **WARNING:** Do not use corrosive detergents for cleaning.
- **WARNING:** To reduce the risk of fire, electric shock, or injury to persons, do not use replacement parts that have not been recommended by the manufacturer. (e.g. Parts made at home using a 3D printer).
- **NOTE:** Before installing the fan, please check and inspect all of the fan components and make sure they have all been received in good condition. Contact the manufacturer if there are any missing, damaged, or broken parts.

# Fan Diagram

Before installing, please check to make sure you have received all the necessary components for installation. Some extra hardware may also have been included.

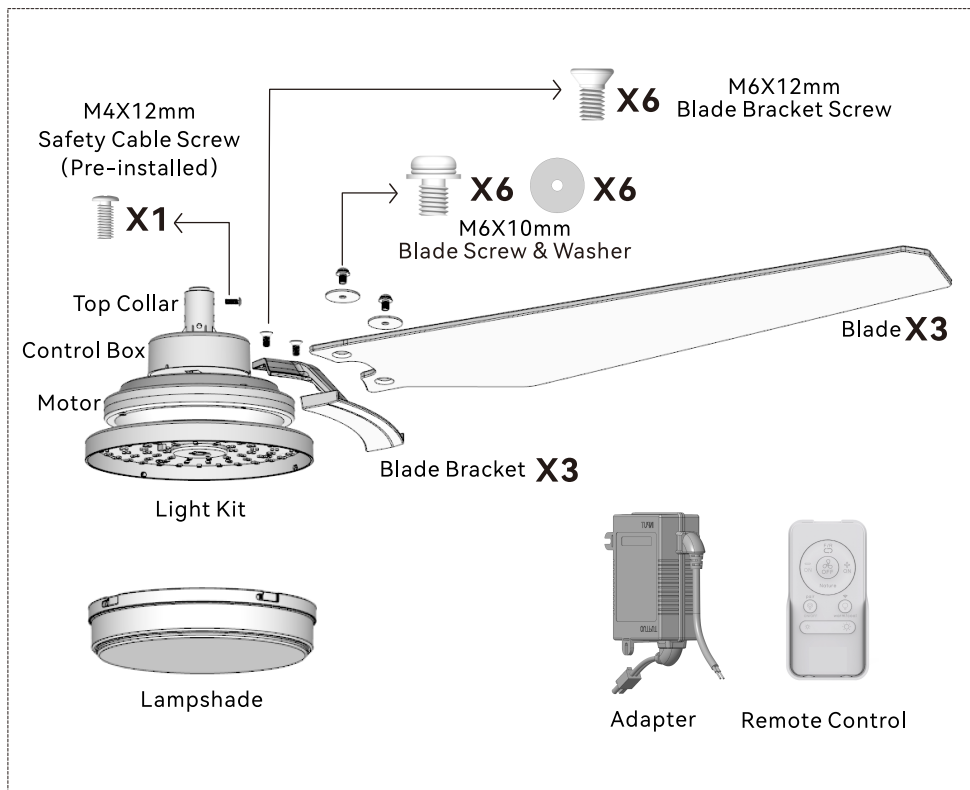
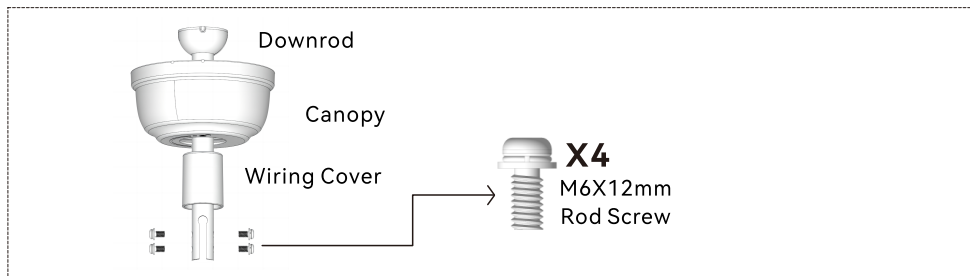
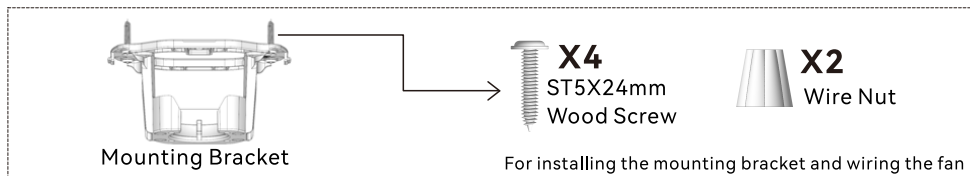

# Installation

---

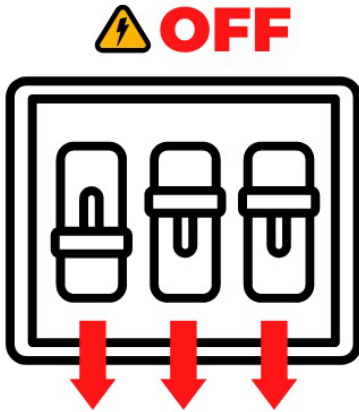

**WARNING:** To avoid serious injury or death, turn off the power at the circuit breaker before installing the fan.

## Tools you'll need



Phillips  
screwdriver



Step ladder

# Installation: Fan Blades

## 1. Assemble the Fan Blades

1.1 Locate the blade attachment screws and washers included in the hardware pack. Use these screws and washers to firmly attach each blade to the blade bracket, as demonstrated in Fig. 1.1.

1.2 Follow the same procedure for the remaining blades, making sure all screws are tightly secured to ensure a stable installation.

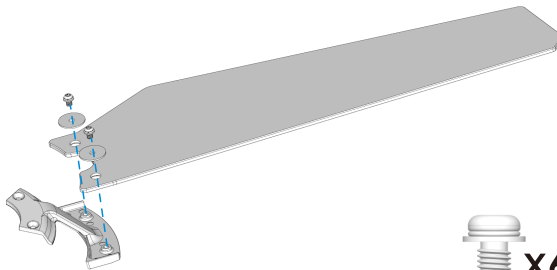

Fig. 1.1



## 2. Install the Fan Blades

Gently place the motor housing. Secure the blade brackets, along with the assembled fan blades, to the motor housing using the blade bracket screws included in the hardware pack.

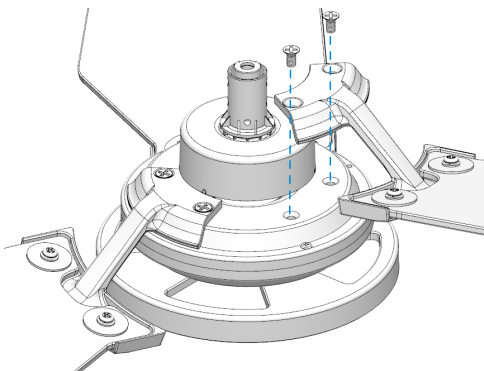

Fig. 2.1



# Installation: Downrod

## 3. Attach the Downrod

3.1 Assemble the downrod as shown in Fig. 3.1. Insert the downrod through the canopy and wiring cover.

**Note:** If you choose to install a safety cable onto your ceiling fan, you will also need to run it through the downrod.

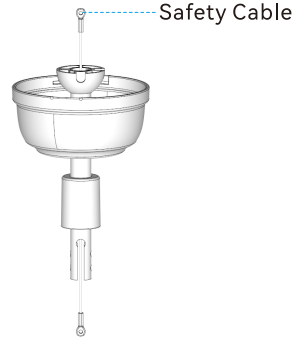

Fig. 3.1

3.2 Thread the motor wire plug through the downrod, pull out the slack from the motor wire plug and safety cable upward, and insert the downrod into the collar on top of the motor assembly. Align the holes at the bottom of the downrod with the holes in the collar on top of the motor housing.

Remove the pre-installed safety cable screw. Install the safety cable and re-insert the previously removed screw back through the hole, but do not tighten yet. Check the top collar to make sure the holes are aligned to install the four rod screws (included in the package), and securely tighten down all the screws to ensure a proper connection as shown in Fig. 3.2.

Slide the wiring cover down until it rests on top of the motor assembly as shown in Fig. 3.3.

**Note:** Before sliding the downrod over the collar on top of the motor assembly, make sure to remove the end of the safety cable from the downrod.

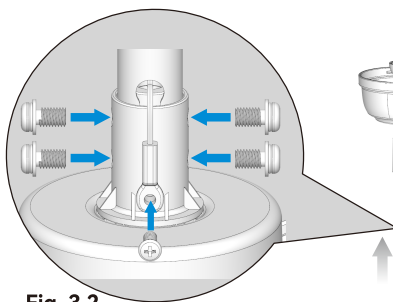
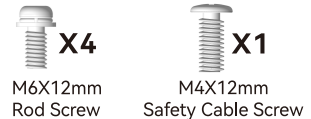

Fig. 3.2

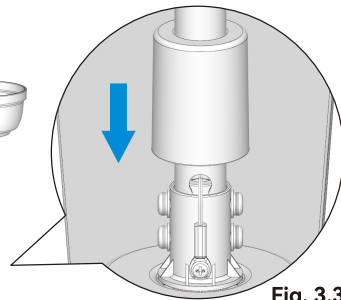
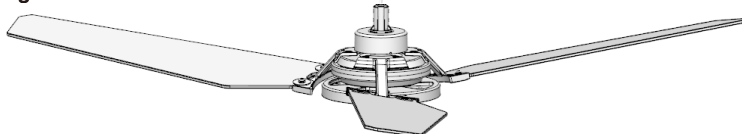

Fig. 3.3



# Installation: Mounting Bracket

---

## 4. Install the Mounting Bracket

Install the mounting bracket to the ceiling box, as shown in Fig. 4.1 below. Rotate the mounting bracket in different directions so that the bracket mounting holes match the screw holes of the ceiling box.

**Note:** This mounting bracket is a standard cable box. If the mounting bracket is installed at the outlet box, it should be installed on the outlet box with two screws matching the outlet box itself, as shown in Fig. 4.1.

**WARNING:** DO NOT use plastic outlet box. Use only U.L. listed outlet boxes marked "Acceptable for Fan Support of 15.9 kg (35 lbs ) or less".

This bracket can also be mounted to a wooden ceiling beam. In that case, use the four ST5x24mm wood screws to lock the corresponding holes on the left and right sides of the bracket as shown in Fig. 4.2.

**Note:** The wooden ceiling beam must meet the tensile test of 30kg for installation.

It is also possible to install the mounting bracket directly to a concrete ceiling and use four anchors (not included) to lock the left and right corresponding holes of the bracket to the ceiling.

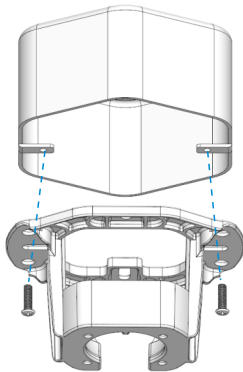

Fig. 4.1

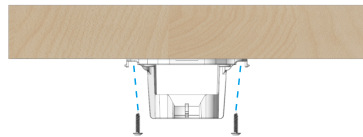

Fig. 4.2

# Installation

---

If you have an angled or vaulted ceiling (see Fig. 4.3)

1. When installing the mounting bracket, the bracket groove should be facing upward, as shown in Fig. 4.4. Do not install the bracket with the groove facing downward, as shown in Fig. 4.5.
2. You will need a longer downrod.
3. The maximum angle is 27 degrees.

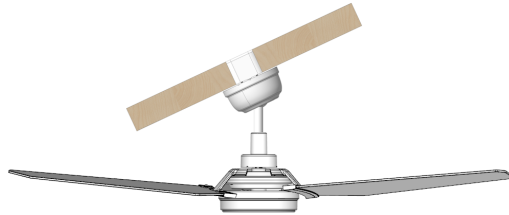

Fig. 4.3

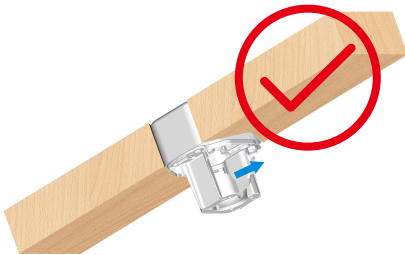

Fig. 4.4

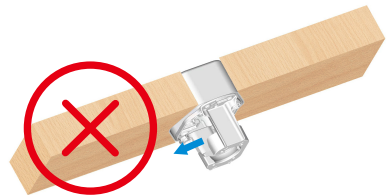

Fig. 4.5

# Installation: Hanging

## 5. Hang the Fan

**WARNING:** To reduce the risk of fire, electric shock, or other personal injury, mount the fan only to an outlet box or supporting system marked acceptable for fan support and use the mounting screws provided with the outlet box.

**WARNING:** Check to see that all connections are tight, including ground, and there are no visible bare wires at the wire nuts (except for the ground wire).

**WARNING:** To reduce the risk of fire or electric shock, do not use this fan with any solid-state speed control device.

**WARNING:** To avoid any electrical shock, be sure electricity is turned off at the main fuse box before wiring.

5.1 Install the ball end of the downrod into the opening of the mounting bracket. Rotate the downrod until the tab on the mounting bracket is securely seated in the slot in the downrod ball, as shown in the enlarged image in Fig. 5.1.

**⚠ WARNING**

The fan and/or downrod should not rotate in the mounting bracket when installed correctly. Failure to properly align the slot in the downrod ball with the tab on the mounting bracket may result in the fan falling, causing serious injury or death.



5.2 Attach the other end of the safety cable to a secure location. Fasten the safety cable to the ceiling using a screw and washer (not included), as depicted in Fig. 5.2.

**Note:** Installing the ceiling fan with a safety cable is an extra safety feature. It secures the fan to the ceiling hook or other attachment point and prevents the fan from falling even in the case of material failure.

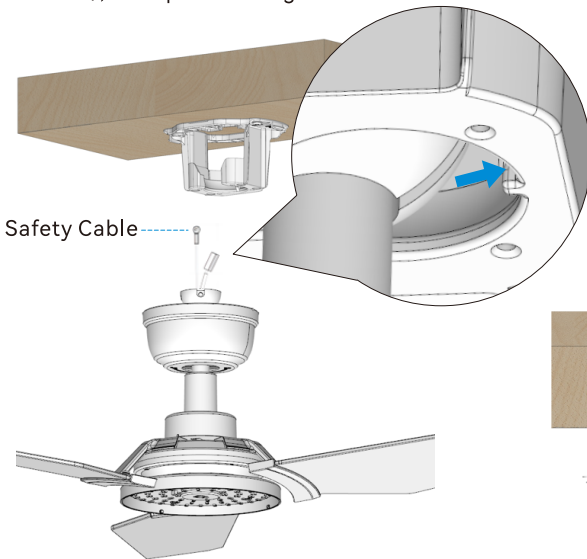

Fig. 5.1

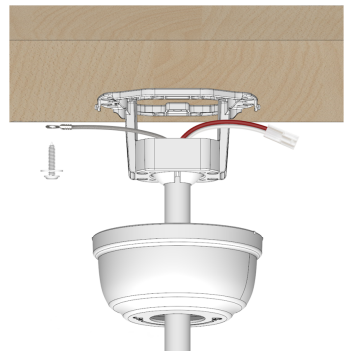

Fig. 5.2

# Installation: Wiring

## 6. Connect the Wiring

6.1 Slide the adapter horizontally into the mounting bracket in the direction of the arrow shown in Fig. 6.1, with the flat side facing the ceiling. Make sure the adapter is pushed in the correct direction according to the upper patterns of the mounting bracket. The input wires of the adapter will wrap around the outside of the mounting bracket.

6.2 Connect the DC output wire plug of the adapter to the motor wire plug which passes through the downrod, as shown in Fig. 6.2. Connect the input wires of the adapter to the supply wires, making sure to match the correct colors as shown in Fig. 6.2.

Securely fasten the Green/Yellow wire from the mounting bracket to the supply Ground wire using a wire nut, and the White wire of the adapter to the supply White (Neutral) wire and the Black wire of the adapter to the supply Black/Red (Hot/Live) wire, using wire nuts. Carefully tuck all wires into the canopy and hide them inside the ceiling.

6.3 DO NOT stand upright (as shown in Fig. 6.3) or place the adapter incorrectly (as shown in Fig. 6.4), otherwise the adapter cannot be inserted into the mounting bracket, which will affect the wiring.

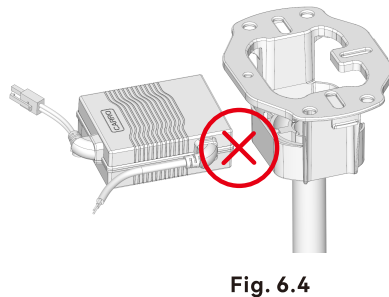
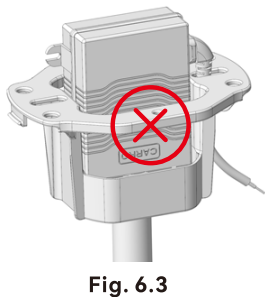
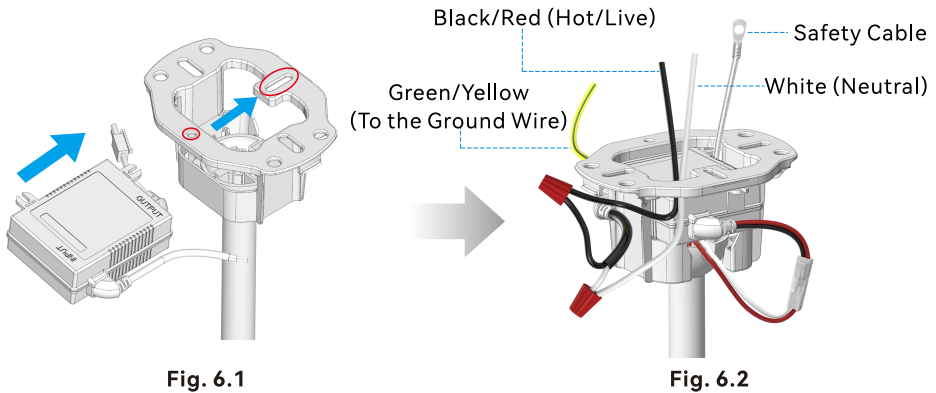

# Installation: Canopy

## 7. Install the Canopy

There are two types of canopies and two ways to install them. Please follow the instructions below before installation.

### A: The screws of the mounting bracket are exposed.

Make sure all wires are tucked into the canopy. Raise the canopy to the mounting bracket and align the holes in the canopy with the two mounting bracket screws. Then, turn the canopy in the direction of the arrow shown in Fig. A until the mounting bracket screws engage from the larger slots of the canopy to the smaller ones. Tighten the screws securely to fix the canopy onto the mounting bracket.



(A)

### B: There are no screws on the mounting bracket.

Make sure all wires are tucked in the canopy. Raise the canopy to the mounting bracket and align the two notches inside the top of the canopy with the two tabs on the top of the mounting bracket. Attach the canopy by lifting and twisting it until it stops.

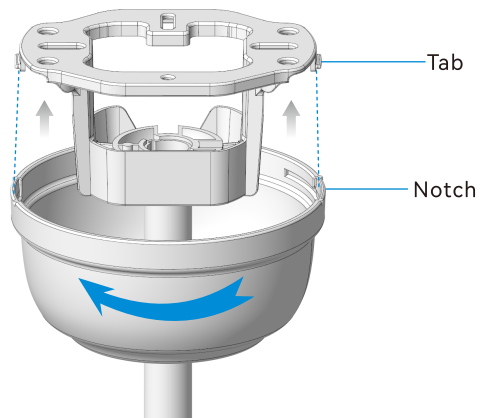

(B)

# Installation: Lampshade / Power On

## 8. Install the Lampshade

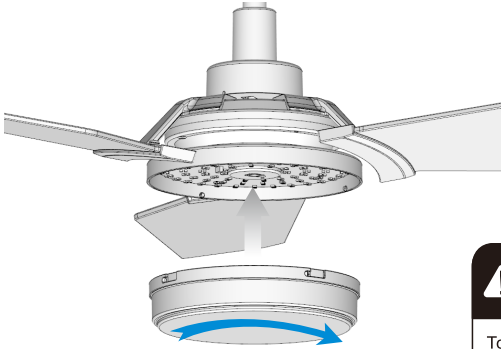

Fig. 8.1

Align the slots of the lampshade with the slots of the light kit pan, and turn the lampshade clockwise to securely lock it into place, as shown in Fig. 8.1.

**Note:** Do not over tighten the lampshade.

**⚠ WARNING**

To prevent **SERIOUS INJURY** or **DEATH**, make sure that the lampshade is properly secured. Allow the lampshade to cool completely before attempting to remove it.



## 9. Power On

At this time, the ceiling fan has been installed. Turn on the power supply from the circuit breaker of the main switch or the room where the ceiling fan is installed. Once the power is on, check to see if the fan light is illuminated and pair the fan with the remote immediately.

**Note:** Please be aware that this ceiling fan may produce noticeable operating sounds at specific wind speeds. This is a normal operating characteristic and does not indicate any issues with its functionality.

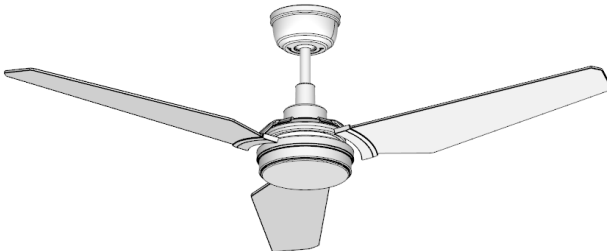

# Remote Control Instructions

## Pair the Remote Control to Your Fan

Power on the fan and pair the remote to the fan within 1 min. To pair remote to fan, press and hold  button for 5-10 secs to pair. Successful pairing will trigger the fan light off.

**Note:** If you do not pair the fan to the remote within 1 minute of connecting it to the power, you will need to reset the fan by disconnecting it from the power before attempting to pair the remote again.

## Remote Control Button Definitions



Turn the fan off.



Switch between summer mode and winter mode.

· Summer mode - (Counter-clockwise)

· Winter mode - (Clockwise)

**Note:** Fan must be running to switch between Summer / Winter modes.



Turn the fan on and decrease fan speed.



Turn the fan on and increase fan speed.

**Nature** Toggle the fan speed between "Nature Mode" and "Breeze Mode". Simulate a soothing breeze that is gentle enough not to disrupt your sleep. To revert to the fan's regular mode, simply press either the speed-up or speed-down button.



Turn the light on or off and remote pairing.

**Note:** Power on the fan and pair the remote to the fan within 1 min. To pair remote to fan, press and hold  button for 5-10 secs to pair. Successful pairing will trigger the fan light off.



Switch between warm light and cool light. WIFI Pairing.

**Note:** Press/hold button for 5 sec. The fan will switch to AP Mode, then select AP Mode on APP, follow the APP control instructions and enable fan Wi-Fi.



Press/Hold button to decrease the light intensity.



Press/Hold button to increase the light intensity.

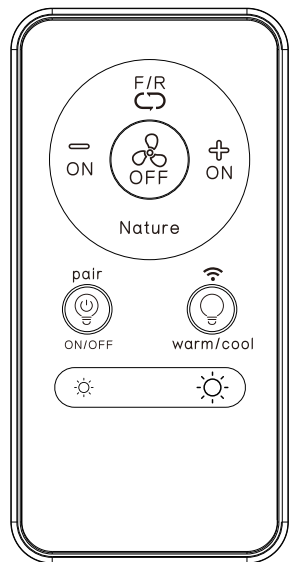

**WARNING:** Do not expose the remote control to direct contact with water.

# Connecting to the App

---

1. First download the free App from the App Store or Google Play.

**Note:** This ceiling fan needs to use 2.4Ghz WIFI to work when connecting the device, and after connecting, it can use the 5Ghz or 2.4Ghz.

2. Open the App to create your account. The account can be registered through E-mail only.
3. Connect the device to the App (Three ways to connect) :

## ①Bluetooth Connect (WIFI & Bluetooth On)

- a. Press "+" button into the device list, then a window will pop up to show you some devices can be connected.
- b. Click "Go to add" (If you click "Do not add" by mistake, please see "Do not add" steps).
- c. Choose the device.
- d. Connect to your home WIFI, then go back to the app and wait for the app to connect with your device.

"Do not add" steps:

- a. Select "Lighting" on the sidebar menu then select "Smart Ceiling Fan" and tap next.
- b. Connect to your home WIFI and tap "Next" to wait for the connection.

**Note:** if your device does not appear in the "go to connect" section, continuously hold the WIFI Pairing button until the hotspot pops up as a discoverable device.

## ②WIFI Connect-AP Mode (WIFI On & Bluetooth Off)

- a. Smart ceiling fan: Press and hold the WIFI button on the remote for 5 seconds for AP Mode.  
Smart switch: Press and hold the "OFF" button for 10 seconds till the indicator light blinks slowly to enter into AP Mode.
- b. Press "+" button to select "Lighting" on the sidebar menu then select "Smart Ceiling Fan".
- c. Connect to your home WIFI (2.4Ghz Only).
- d. Press "Next" button to go to connect the fan's WIFI signal.
- e. Choose the fan's WIFI signal "XXXX" then go back to the app.
- f. Wait for the connection.

## ③WIFI Connect-EZ Mode (WIFI On & Bluetooth Off)

- a. Press "+" button to select "Lighting" on the sidebar menu then select "Smart Ceiling Fan".
- b. Connect to your home WIFI (2.4Ghz Only) and next.
- c. Click the right corner on the top to choose "EZ Mode".
- d. Tap "Next" button to wait for the connection to complete.

# Connecting to Smart Devices

---

1. Connect the device to Google Home:

- a. Make sure you have connected the device to the App and it is working normally.
- b. Open the Google Home app, select set up a device, and choose "Works with Google".
- c. Search for , log in with your App account and password, then authorize and connect with the App.
- d. Then the Google Assistant will find the device automatically.

2. Connect the device to Siri shortcuts:

Make sure you have connected the device to the App and it is working normally.

- a. Tap "Scene" on the main menu.
- b. Tap "Create Scene".
- c. Tap "Launch Tap To Run".
- d. Tap "+".
- e. Run the device.
- f. Choose the device you want to control by Siri.
- g. Select the function you want to control by Siri.
- h. Then save the function setting.
- i. To add to Siri, choose the scene you have created, and then select add to Siri.
- j. Enter the sentence you want to say to initialize the device, and add to Siri.

# Troubleshooting

Try these troubleshooting steps before contacting Customer Service. For additional operation, maintenance, and troubleshooting information, please contact our customer service center.

SYMPTOM	POSSIBLE SOLUTION
Fan not spinning	<p>① Make sure the fan is getting power. ② Check your circuit breaker or fuse panel and wall switch for functionality. ③ Check to make sure the fan wires are correctly connected to the house wires. ④ Remote control must be paired with the fan within 1 minute after connecting the fan to the electricity. ⑤ If you have paired the app but the fan still does not work (light and fan both didn't work) or couldn't pair the app to the fan, try to reset the fan: to reset the fan, cut the power for 10 minutes, then turn the power on and press the pairing button  on the remote for 5-10 seconds until the fan light turns off, then pair the App again. ⑥ Use a multi-meter and test the wiring harness to see if there is any electrical output. ⑦ All the pin wiring on the circuit board must be inserted tight and in the correct position. ⑧ Remote needs to be paired with the fan first. ⑨ Make sure the fan blades spin freely. ⑩ If you're using a wall control, check the power to the breaker from your control and try working your ceiling fan manually. (Normal switch is only used for connecting the fan to the house electricity. )</p>
Fan light not working	<p>① Make sure LED wires are connected to the circuit board. ② Make sure the whole fan is powered.</p>
The fan is noisy and wobbling	<p>① Check if the blade screws are NOT rubbing against any part of the motor housing. ② Check if the pin wires are NOT touching against any moving parts. ③ Check if the bottom wire cover is NOT hitting the motor. ④ Confirm the canopy is NOT touching the ceiling while the fan is in operation. ⑤ Check the down rod is NOT slanted. ⑥ Tighten any loose screws on the light kit, fan blades, motor coupling, down rod, brackets and mounting hardware. ⑦ Confirm the hanger ball is firmly seated in the mounting bracket. ⑧ The ceiling beam must meet the minimum tensile test strength of 30kg for installation. ⑨ Make sure the blades and brackets are NOT bent or deformed. ⑩ Verify the wire connections are not rattling against each other. ⑪ Verify the fan blades are not cracked. If the fan blades are cracked, replace the damaged blades with a new blade set from the same brand as your ceiling fan to ensure compatibility. ⑫ Confirm the light kit is NOT slanting and hitting the motor.</p>
Unable to pair remote and app	<p>① Check if the wires are connected in the correct position or not. ② Check the batteries in the remote. ③ Disconnect the power for 10 minutes, reconnect the power and pair the remote with the fan immediately, within 1 minute. Also try pairing the app to reconnect. ④ The WiFi must be 2.4Ghz, incompatible with 5Ghz WiFi or combined with 5Ghz. This ceiling fan needs to use 2.4Ghz WIFI to work when connecting the device, and after connecting, it can use the 5Ghz or 2.4Ghz. ⑤ App must be the newest version. ⑥ Connect with correct app.</p>
Fan or light turning on or off by themselves	<p>① Confirm the circuit breaker is not malfunctioning. ② Verify the wire connections are not frayed. ③ Check the app is not set to a timer or schedule. ④ Cut the fan power for 10 minutes then power on again. ⑤ All the pin wiring on the circuit board must be inserted tight and in the correct position.</p>

# Care & Cleaning

---

**WARNING:** Power off the fan before performing maintenance or cleaning the fan.

1. Check the support connections, brackets, and blade attachments twice a year. Make sure they are secure. Because of the fan's natural movement, some connections may become loose over time. It is not necessary to remove the fan from the ceiling.
2. Clean your fan periodically. Use only a soft brush or lint-free cloth to avoid scratching the finish. The plating is sealed with a lacquer to minimize discoloration or tarnishing.
3. (Optional) Apply a light coat of furniture polish to the wood blades.
4. (Optional) Cover small scratches with a light application of shoe polish.

**DO NOT:**

1. Use water when cleaning. Water could damage the motor, or the wood, or possibly cause an electrical shock.
2. Apply oil to your fan or motor. The motor has permanently lubricated sealed ball bearings.

## FCC Statement

---

**Note:** This equipment has been tested and found to comply with the limits for a Class B digital device, pursuant to part 15 of the FCC Rules. These limits are designed to provide reasonable protection against harmful interference in a residential installation. This equipment generates, uses and can radiate radio frequency energy and, if not installed and used in accordance with the instructions, may cause harmful interference to radio communications. However, there is no guarantee that interference will not occur in a particular installation. If this equipment does cause harmful interference to radio or television reception, which can be determined by turning the equipment off and on, the user is encouraged to try to correct the interference by one or more of the following measures:

- Reorient or relocate the receiving antenna.
- Increase the separation between the equipment and receiver.
- Connect the equipment into an outlet on a circuit different from that to which the receiver is connected.
- Consult the dealer or an experienced radio/TV technician for help.

**WARNING:** Changes or modifications to this unit not expressly approved by the party responsible for compliance could void the user's authority to operate the equipment.