





NO.	HARDWARE	Q' TY
A	Flat Washer $\phi 5/16"$ *22 	10PCS
B	Locr washer $\phi 5/16"$ *13mm 	10PCS
C	BOLT $\phi 5/16"$ *3-1/4" 	4PCS
D	BOLT $\phi 5/16"$ *2-1/4" 	6PCS
E	Allen Wrench 5mm 	1PC

NO.	PART NAME	Q' TY
①	CHAIR BACK	1PC
②	SEAT CUSHION	1PC
③	FRONT LEG	2PCS

STEP 1

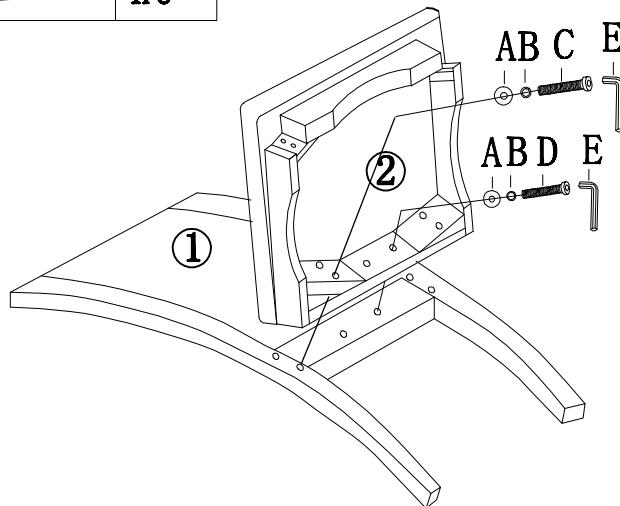

STEP 2

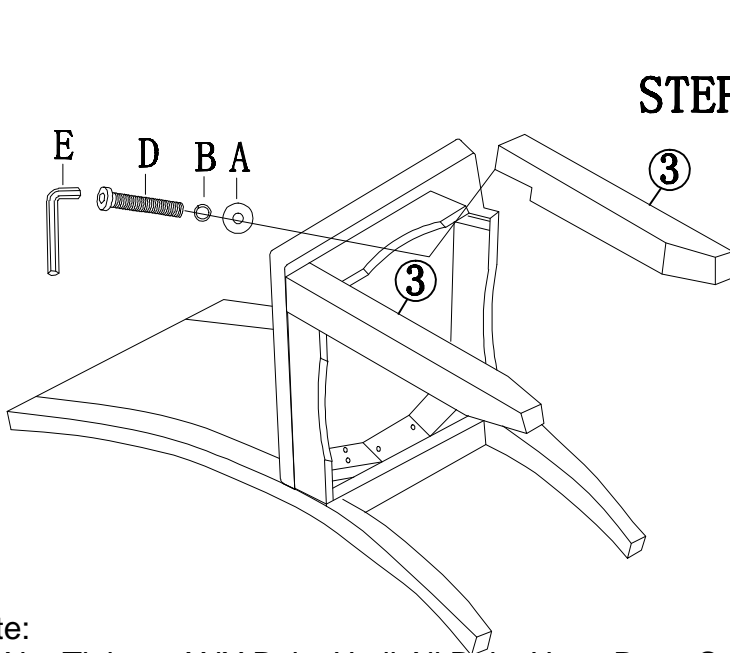

STEP 3

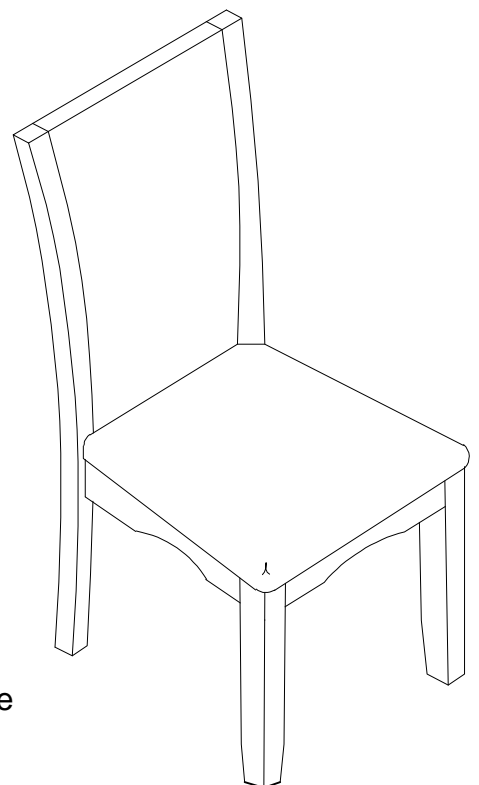

Note:

Do Not Tighten ANY Bolts Until All Bolts Have Been Started,
Stand The Chair Upright On Flat Surface. Put Pressure On The
Chair And Rock it Back And Forth To Adjust To Level.
Tighten All Bolts With Allen Wrench.