

THKFBV019WH2BW

INSTALLATION INSTRUCTIONS

*The vessel and faucet set is not included

DIMENSIONS



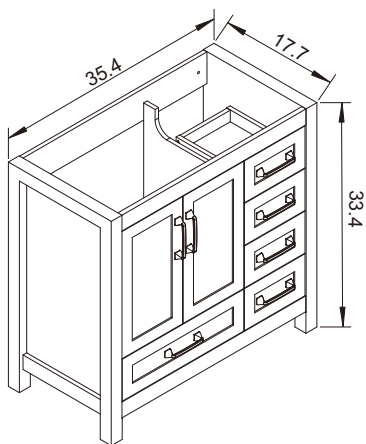



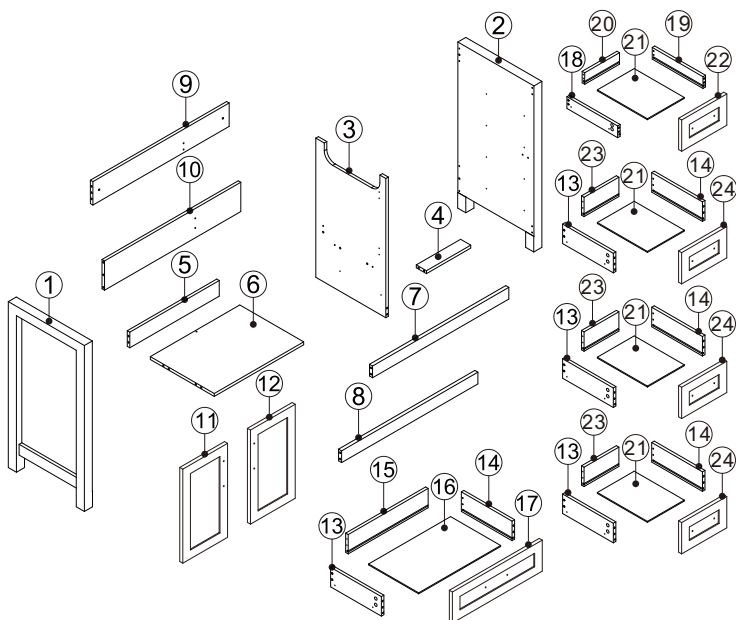































Unit:inch



ASSEMBLY DIAGRAM





PARTS LIST

PARTS LIST			HARDWARE LIST		
No.	Description	QTY	No.	Description	QTY
1		1	A	 Three-in-one Connector	53
2		1	B	 Wood Plug	10
3		1	C	 Screws M4x14	88
4		1	D	 Slider	10
5		1	E	 Foot nail	4
6		1	F	 Screws M4x30	20
7		1	G	 Hinges	2
8		1	H	 Hinges	2
9		1	I	 Handle Screws M4x22	4
10		1	J	 Handle	7
11		1	K	 Bracket	1
12		1	L	 Screws For Fix On The Wall M5.5x60	2
13		4	M	 Handle Screws M4x18	10
14		4	N	 Cover	53
15		1			
16		1			
17		1			
18		1			
19		1			
20		1			
21		4			
22		1			
23		3			
24		3			

CAUTION: Please confirm the parts list before installation

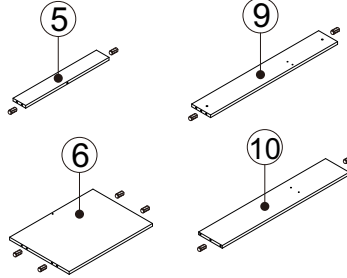
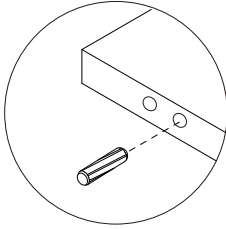

STEP 2

HARDWARE LIST		
B		10PCS
		



- Insert the wooden dowel pins into the shelves.

STEP 3

HARDWARE LIST		
E		4PCS
D		10PCS
C		30PCS

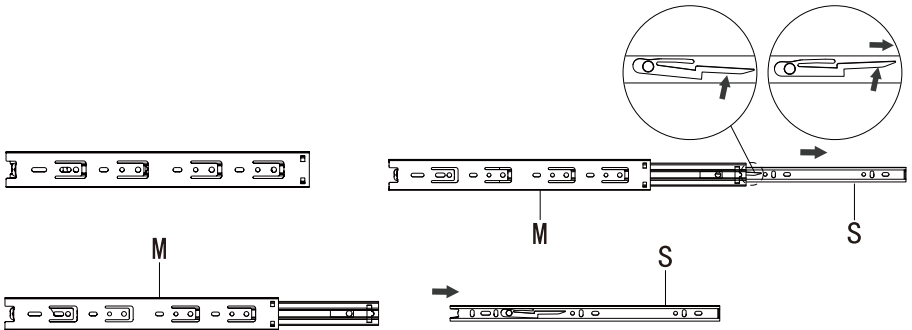

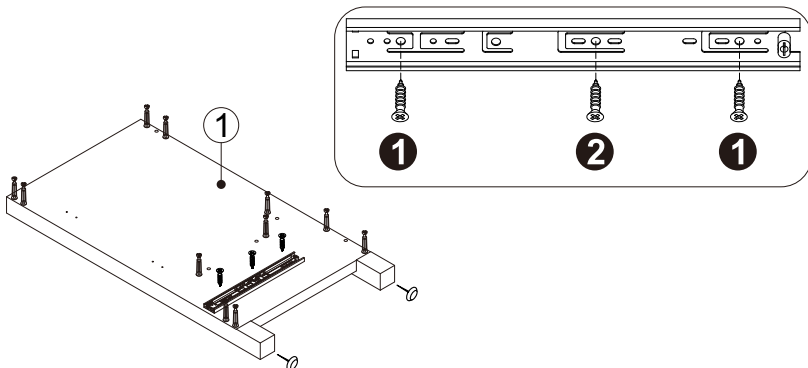

- Keep pressing here, then pull out to device the slide.

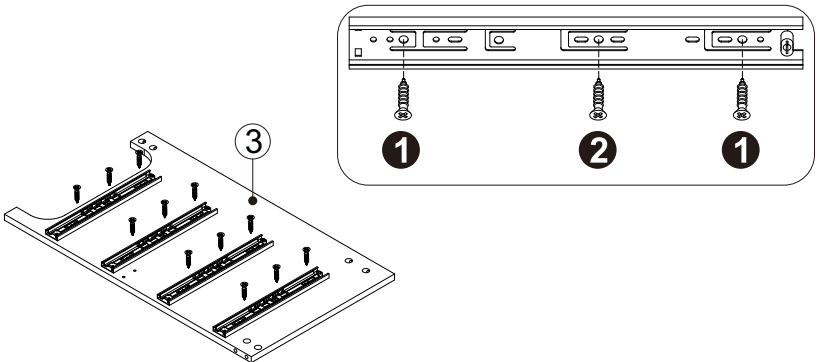
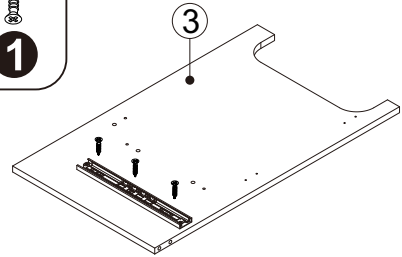
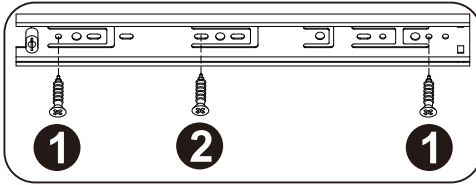
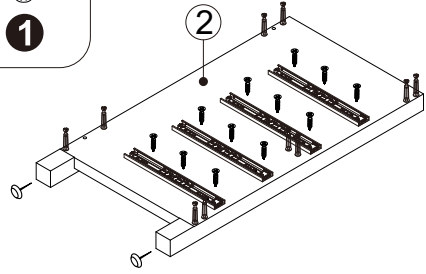
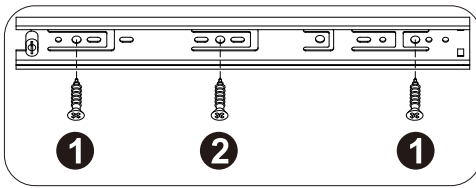



- Refer to the illustration to fix the Slide rails to the board #1,#2,#3 with screws.

STEP 4

HARDWARE LIST		
N		1PCS
A		1PCS

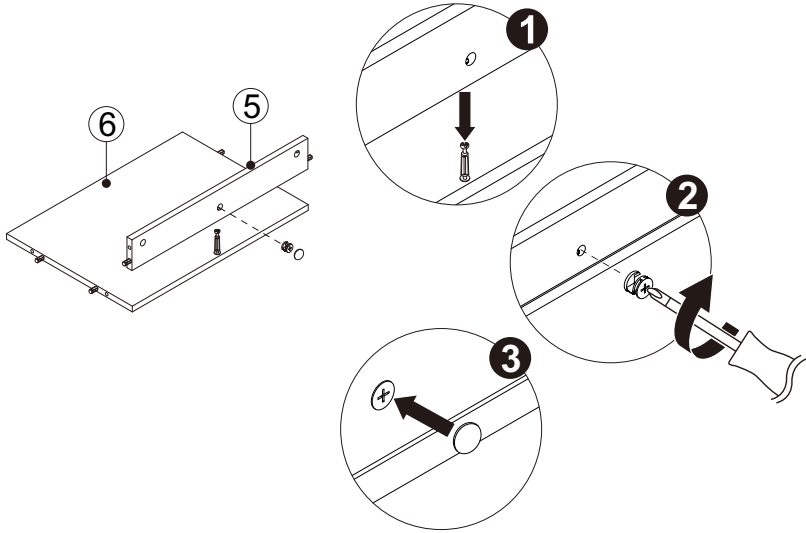

- Insert shelves #5 and #6 downwards to their corresponding positions. Then tighten the cam lock with the cover.

STEP 5

HARDWARE LIST		
N		6PCS
A		6PCS

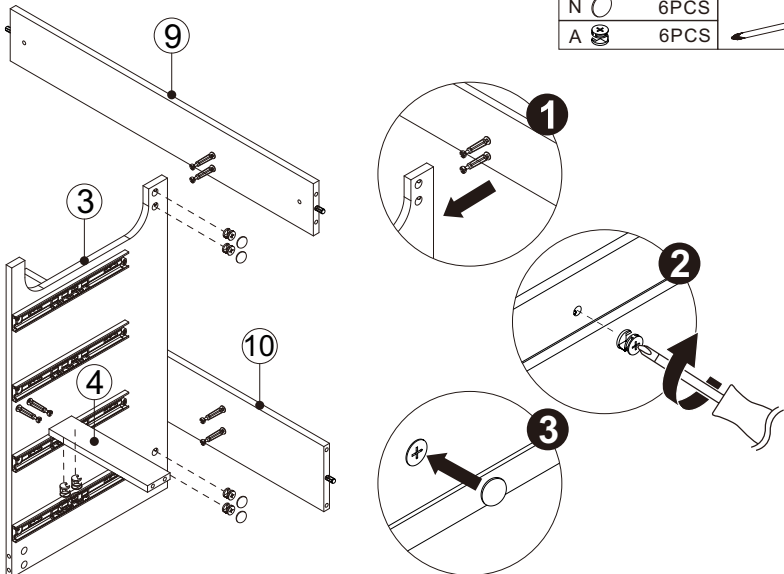

- Refer to the illustration, Insert the boards #9, #10, #4 into the board #3. Then tighten the cam lock with the cover.

STEP 6

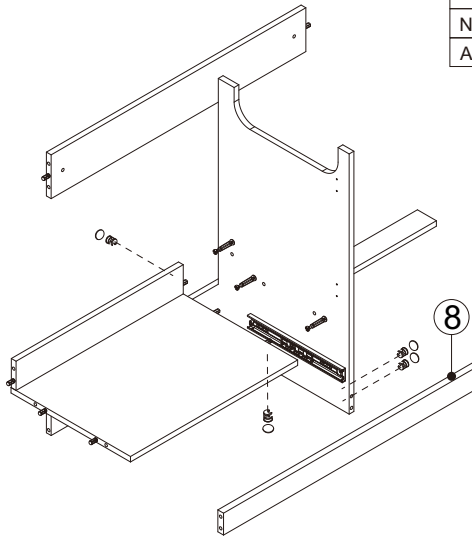



HARDWARE LIST		
N		5PCS
A		5PCS

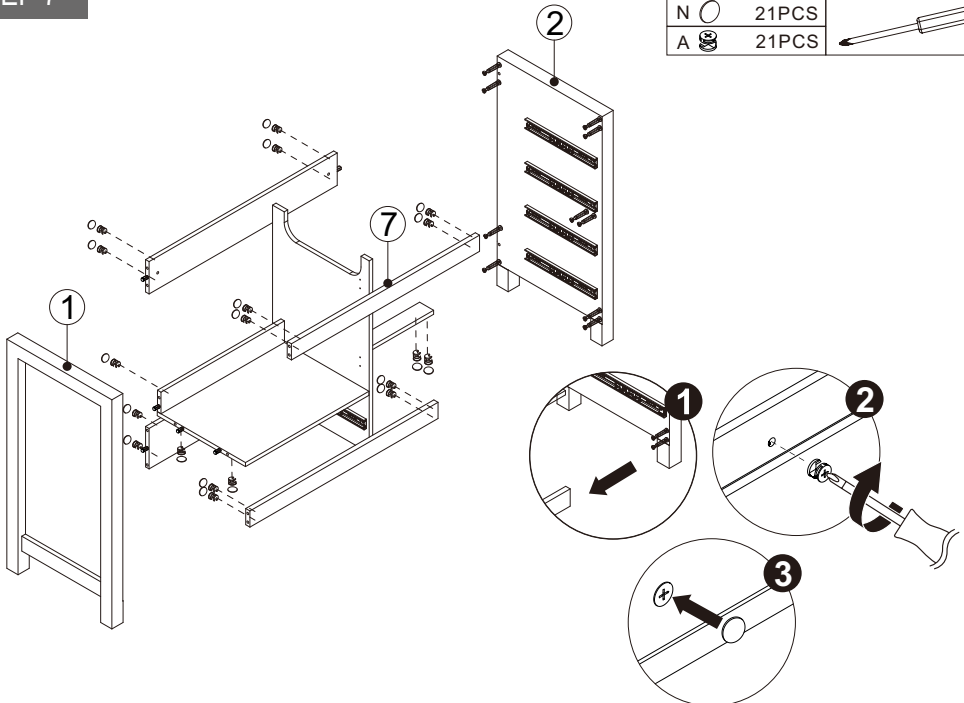

- Already assembled #5,#6 and #8 on the shelf .
Then tighten the cam lock with the cover.

STEP 7



HARDWARE LIST		
N		21PCS
A		21PCS



- Refer to the illustration,already assembled #4,#5,#6,#7,#8,#9,#10 on the shelf #1 and #2.
Then tighten the cam lock with the cover.

STEP 8

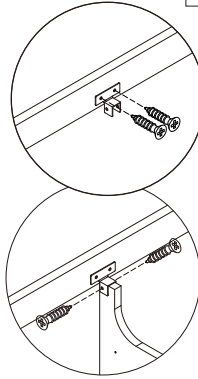
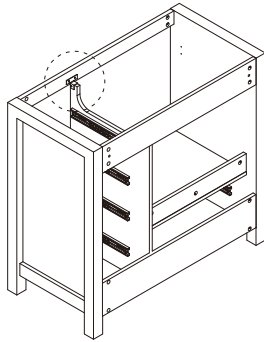

HARDWARE LIST		
K		1PCS
C		4PCS



- Refer to the illustration,lock the angle iron on the board #3 #7 by screws.

STEP 9

HARDWARE LIST		
G		2PCS
H		2PCS
I		4PCS
I		4PCS
C		24PCS
J		2PCS

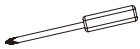
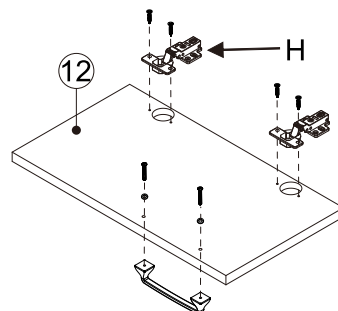
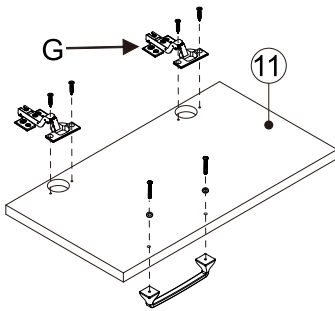
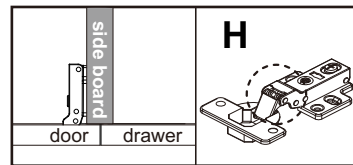
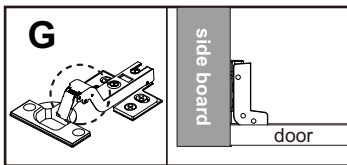
Note:see step 10 to adjust the door's position.

- Use Screws to install the handle and apply Screws to fix the hinge on the shelf #11. Then use Screws to connect the hinge bracket to the cabinet. Repeat these steps for the other door.

STEP 10

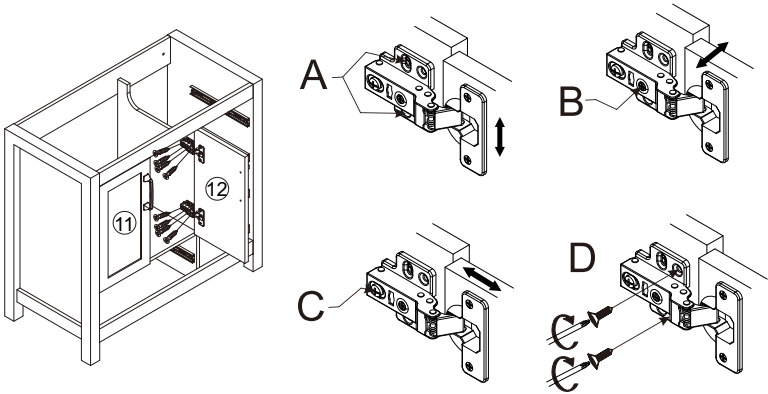

A.Height adjustment

B.Side to side adjustment

C.Depth adjustment

D.After adjustment A/B/C,tighten screws.

- To ensure proper cabinet alignment, refer to the above illustrations for instructions about adjusting the cabinet height, depth and lateral movement.

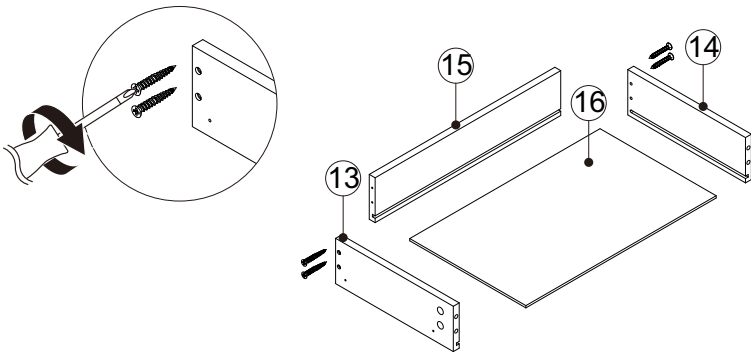

STEP 11

HARDWARE LIST	
F 	4PCS
	



- Refer to the illustration,Connect the side plate #13, #14 with the back plate #15 with screws.Then insert the plate #16 into the finished shelf.



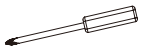
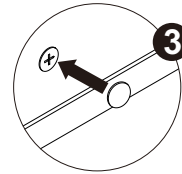
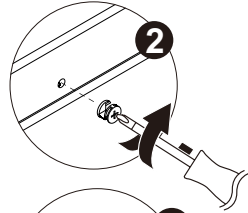
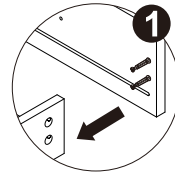
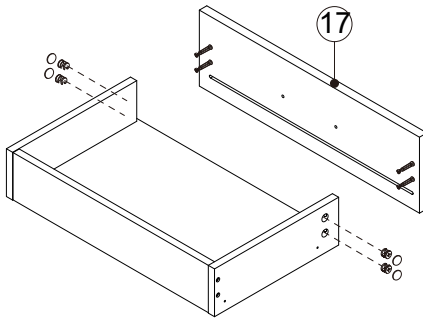

STEP 12

HARDWARE LIST		
N		4PCS
A		4PCS

- Refer to the illustration, Draw the panel #17 is inserted into the prepared plate, Then tighten the cam lock with the cover.

STEP 13

HARDWARE LIST		
J		1PCS
D		2PCS
C		6PCS
M		2PCS
M		2PCS

- Refer to the illustration, Apply Screws to fix the slides on the boards #13,#14. Use Screws to install the handle.

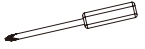
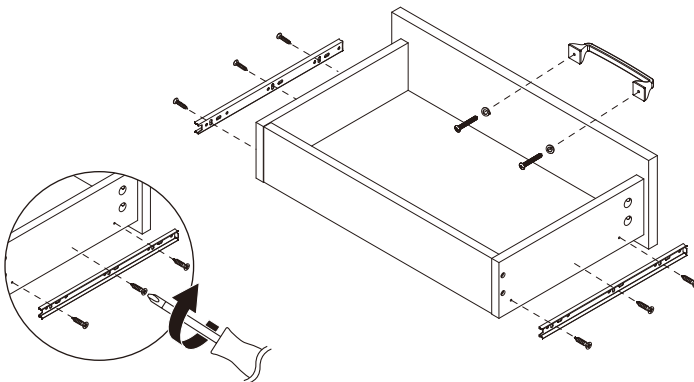
STEP 14

HARDWARE LIST		
F		4PCS
		

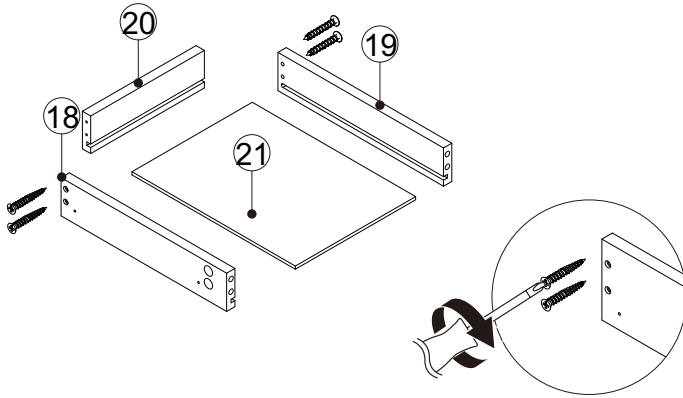

- Refer to the illustration, Connect the side plate #18, #19 with the back plate #20 with screws. Then insert the plate #21 into the finished shelf.



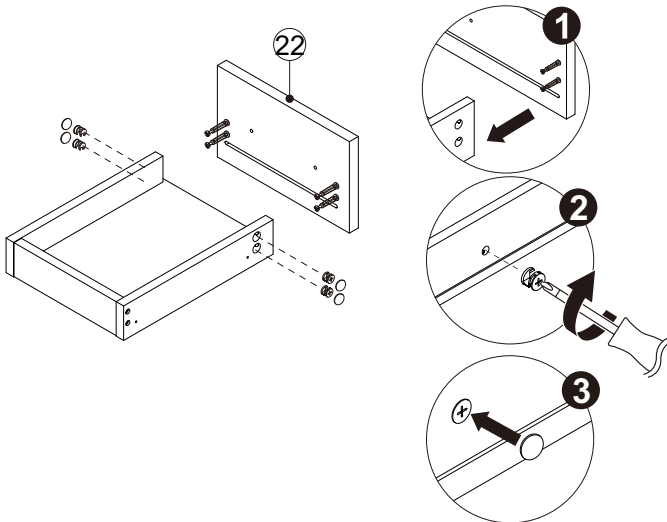

STEP 15

HARDWARE LIST		
N		4PCS
A		4PCS
		



- Refer to the illustration, Draw the panel #22 is inserted into the prepared plate, Then tighten the cam lock with the cover.

STEP 16

HARDWARE LIST		
J		1PCS
D		2PCS
C		6PCS
M		2PCS
M		2PCS

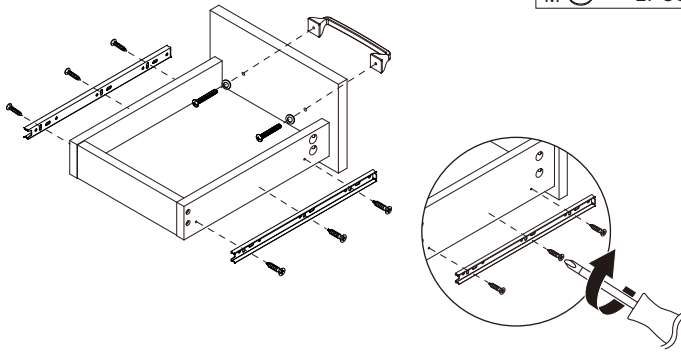
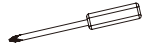

- Refer to the illustration, Apply Screws to fix the slides on the boards #18,#19. Use Screws to install the handle.

STEP 17

HARDWARE LIST		
F		12PCS

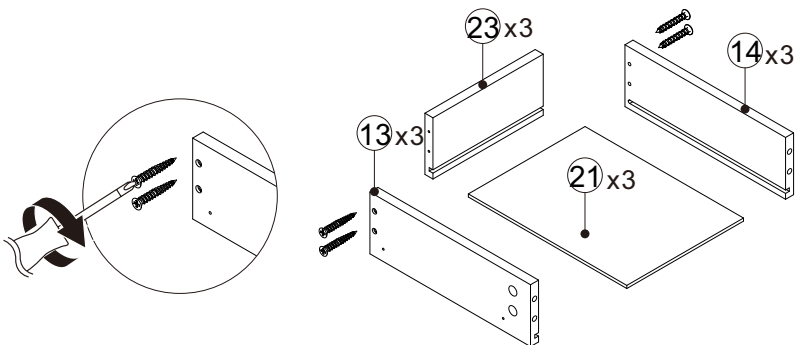
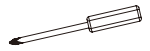

- Refer to the illustration, Connect the side plate #13, #14 with the back plate #23 with screws. Then insert the plate #21 into the finished shelf.



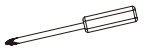
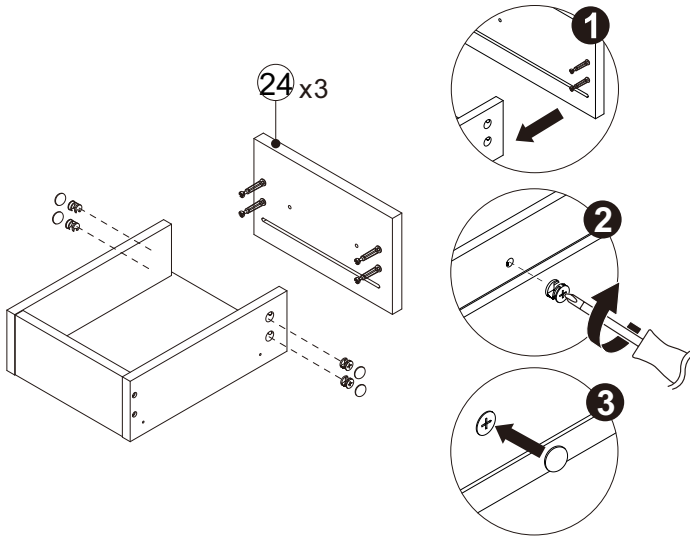

STEP 18

HARDWARE LIST		
N		12PCS
A		12PCS

- Refer to the illustration, Draw the panel #24 is inserted into the prepared plate, Then tighten the cam lock with the cover.

STEP 19

HARDWARE LIST		
J		3PCS
D		6PCS
C		18PCS
M		6PCS
M		6PCS



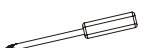
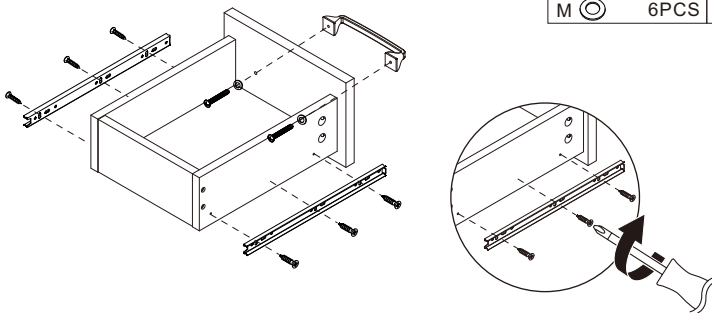

- Refer to the illustration, Apply Screws to fix the slides on the boards #13,#14. Use Screws to install the handle.

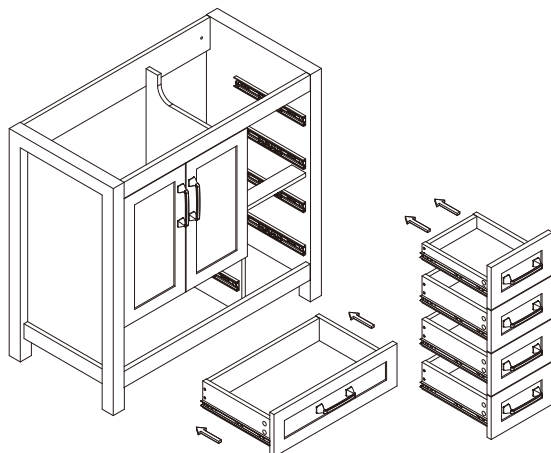
STEP 20



- If the drawers are not in the same level, please adjust the screws in the drawer box.
- Assembled drawers are loaded onto cabinets.

STEP 21

HARDWARE LIST		
L		2PCS
L		2PCS
L		2PCS
L		2PCS

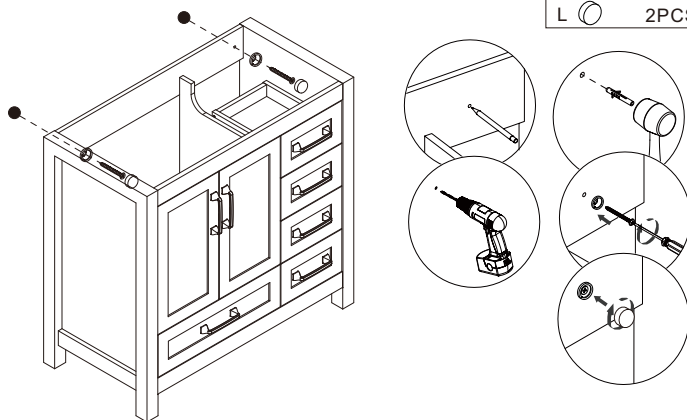

- Refer to the illustration, Draw the spacing between the walls on the cabinet, punch holes in the wall, and fix the cabinet to the wall with screws. Then tighten the nut cover.

STEP 22

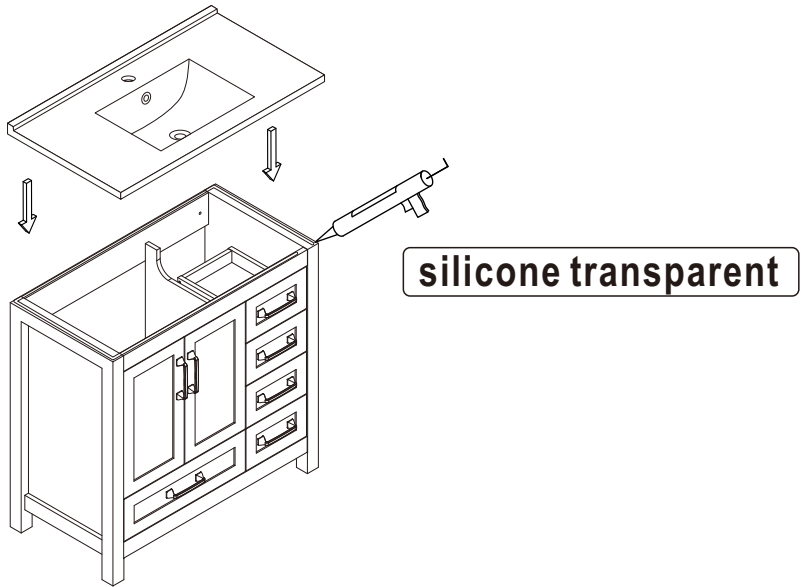

STEP 23

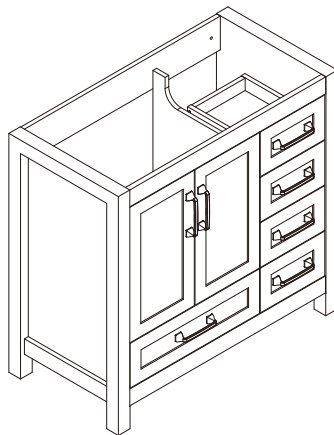

- To help prevent mildew, apply sealant to the space between the wall and the edge of the cabinet.

CARE AND CLEANING

1. Many cleansers contain abrasive and chemical substance which is not suitable for cleaning stainless steel, enamel, plating or plastic products. You may use mild cleansers or soaps to clean the surfaces. Wipe any splashes of cleaner solutions from the surface with a clean soft cloth.
2. Maintain ventilation in the bathroom and separate the dry area from the damp one if conditions permit. Try to open the door and windows of the bathroom to maintain adequate ventilation.
3. This cabinet is built to withstand normal bathroom humidity. For best results, keep this vanity dry and take necessary steps to minimize bathroom humidity by opening windows and doors and using the exhaust fan (if available).
4. To maintain the cabinet door, clean and wipe the door regularly with a soft cloth. Wipe condensation with a dry, soft cloth. Keep away from res and high temperatures.
5. Please do not sit, lean or step on the basin cabinet.

FEEDBACK ★★★★★

Thank you very much for purchasing from us.

We have always been trying to provide the best service and reliable products for every customer.

We sincerely hope you will be satisfied with our products and leave us FIVE STARS and POSITIVE feedback/ review in our page.

However, accident may happen sometimes, please contact us to resolve any issue before leaving a negative feedback.

Many thanks and welcome to our shop again!

Contact number: (323)-393-8260

E-mail: service@eclifeusa.com