

ASSEMBLY INSTRUCTIONS

KITCHEN CART GRANITE TOP



We are here to help!

MADE IN CHINA

PARTS IDENTIFICATION

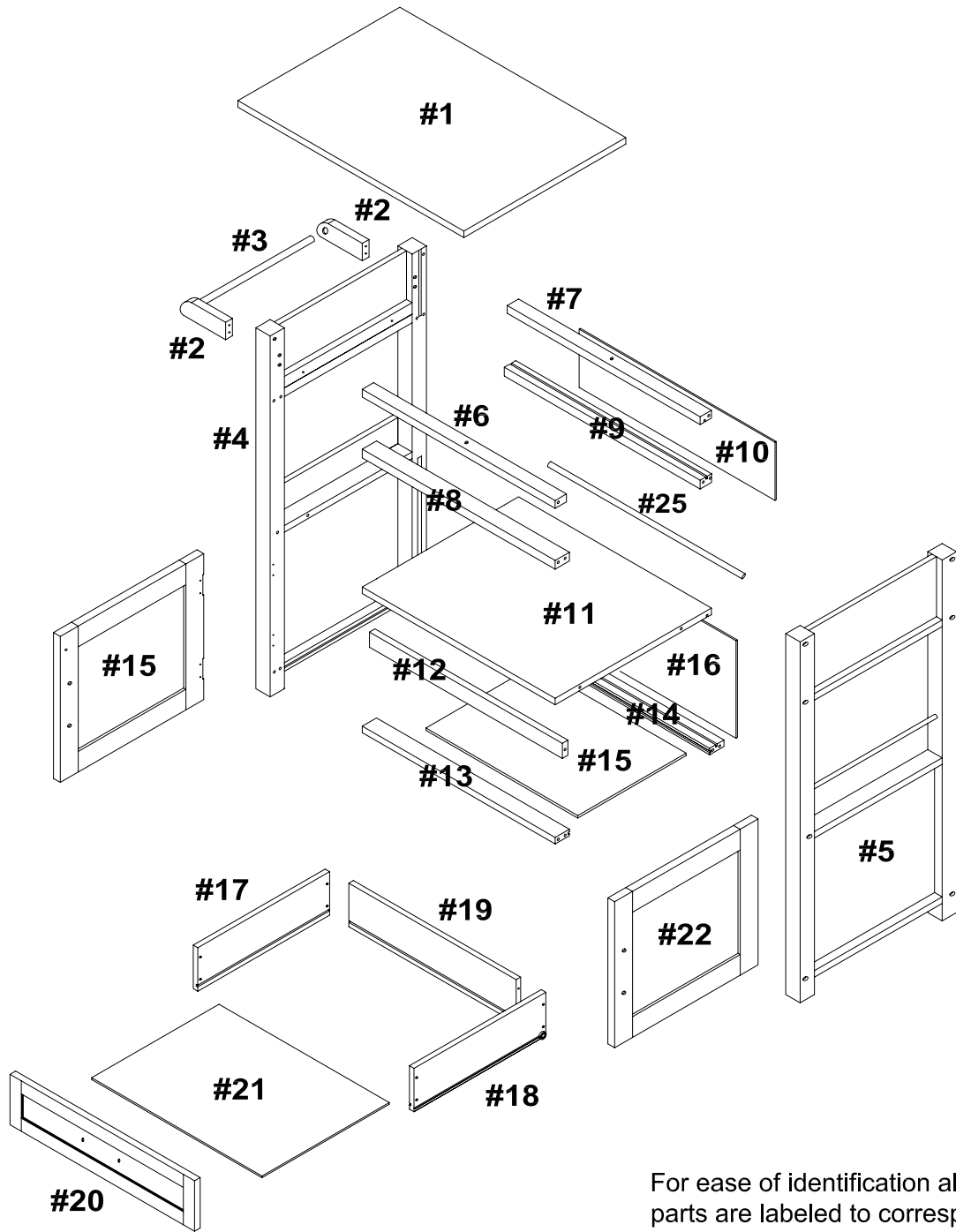







For ease of identification all parts are labeled to correspond to the Step number in which the part is used.

PARTS IDENTIFICATION

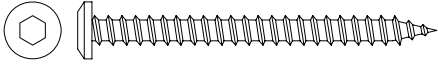
ITEM	DESCRIPTION	QTY
#1	TOP PANEL	01
#2	BLOCK	02
#3	BAR	01
#4	LEFT FRAME	01
#5	RIGHT FRAME	01
#6	FRONT RAIL	01
#7	BACK RAIL	01
#8	FRONT CROSS BAR	01
#9	BACK CROSS BAR	01
#10	BACK PANEL	01
#11	FIXED SHELF	01
#12	LOWER CROSS BAR	01
#13	BOTTOM RAIL	01
#14	BACK RAIL	01
#15	LEFT DOOR	01
#16	BACK PANEL	01
#17	LEFT DRAWER SIDE	01
#18	RIGHT DRAWER SIDE	01
#19	DRAWER BACK	01
#20	DRAWER FRONT	01
#21	DRAWER BOTTOM	01
#22	RIGHT DOOR	01
#23	TUBE	01

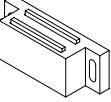
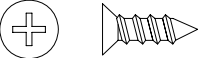
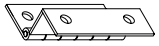

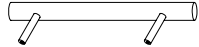
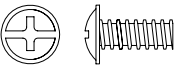







HARDWARE IDENTIFICATION

Please line up the hardware with the correct full size image to make sure you are installing the hardware correctly.

ITEM	PICTURE	DESCRIPTION	QTY
A	 (Ø5mm x 55mm) Not to Scale	SCREW	18
B	 (Ø8mm x 30mm) Full size	WOODEN DOWEL	12
C	 (45mm) Not to Scale	MAGNET DOOR STOP	01
D	 (Ø3mm x 14mm) Full size	SCREW	02
E	 Not to Scale	HINGE	04
F	 (Ø3mm x 12mm) Full size	SCREW	19
G	 Not to Scale	METAL PLATE	02
H	 Not to Scale	HANDLE	03
I	 (Ø4mm x 10mm) Full size	BOLT	02
J	 Not to Scale	CASTER WITHOUT BRAKE	02
K	 Not to Scale	CASTER WITH BRAKE	02

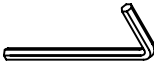
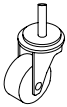
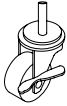
HARDWARE IDENTIFICATION

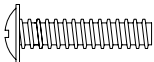
Please line up the hardware with the correct full size image to make sure you are installing the hardware correctly.

ITEM	PICTURE	DESCRIPTION	QTY
J	  (Ø4mm x 30mm) Full size	SCREW	10
K	  (Ø3.5mm x 12mm) Full size	SCREW	04
L	 Not to Scale	SLIDE	01
M	 Not to Scale	SLIDE	01
N	 (Ø8mm x 20mm) Full size	WOODEN DOWEL	02
O	 Not to Scale	ALLEN WRENCH	01
P	 Not to Scale	CASTER WITHOUT BRAKE	02
Q	 Not to Scale	CASTER WITH BRAKE	02
R	  (Ø4mm x 16mm) Full size	BOLT	04
S	 Not to Scale	WOODEN PLUS	14

STEP 1.

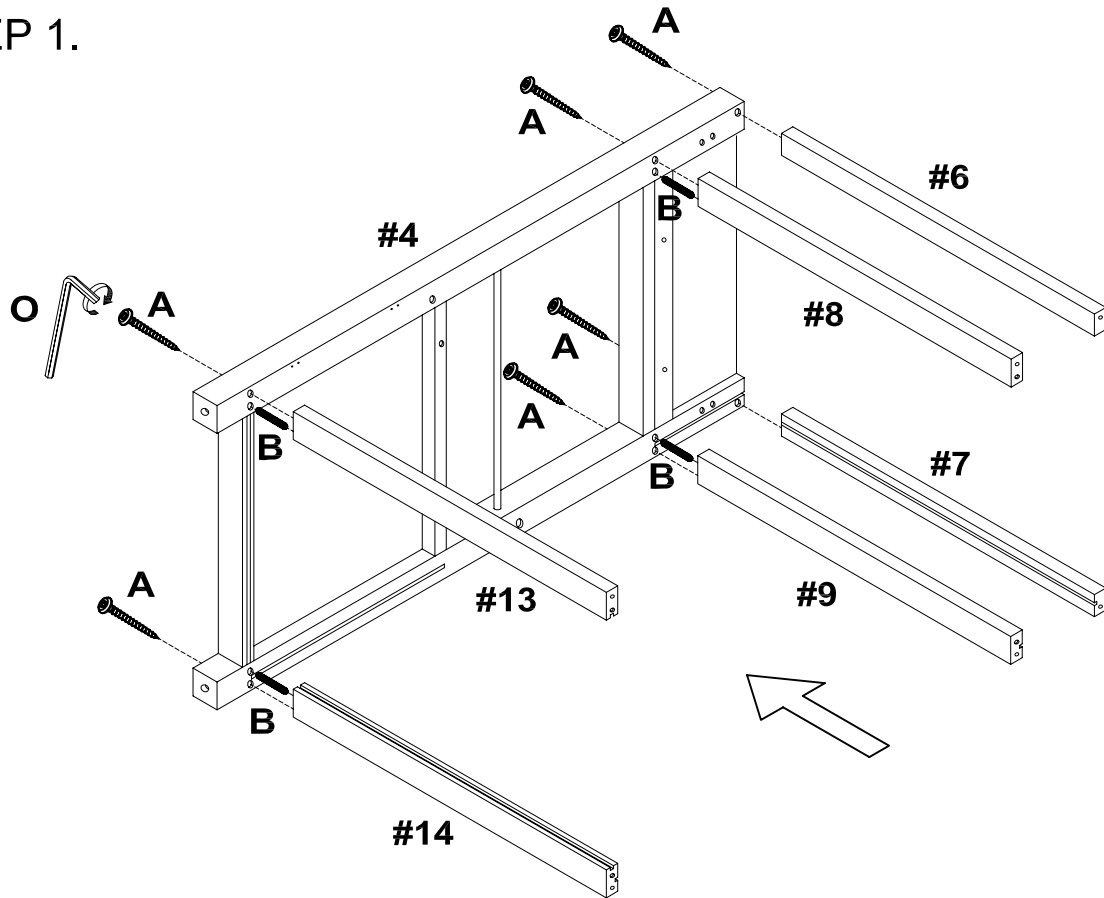

STEP 2.

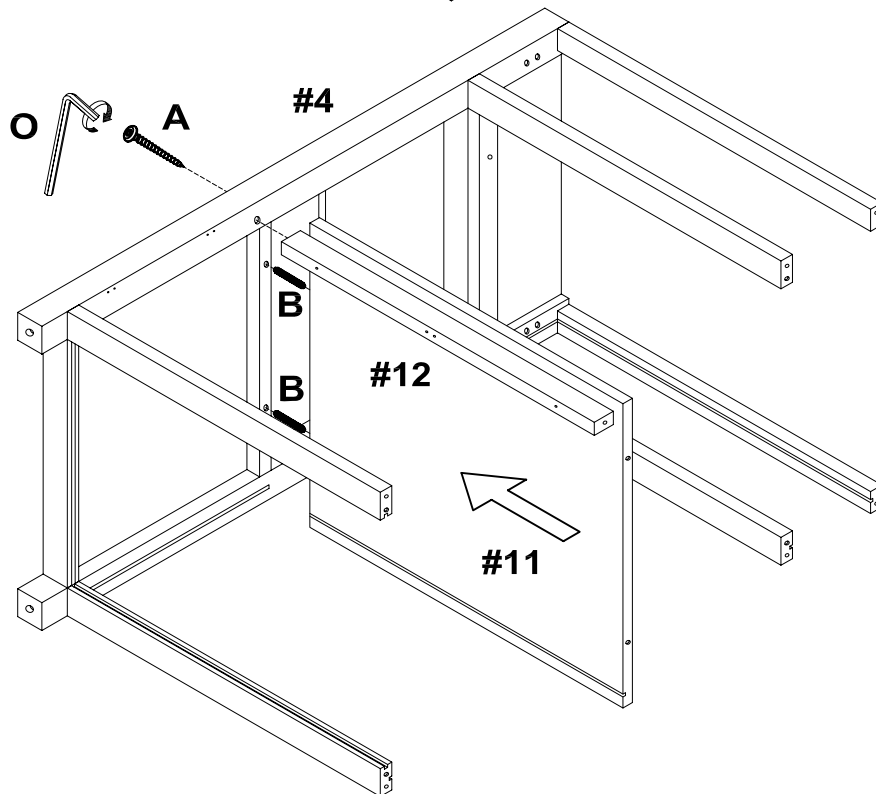

IMPORTANT:

1. DO NOT TIGHTEN BOLTS COMPLETELY UNTIL ALL BOLTS ARE COMPLETELY LINED UP AND INSERTED INTO HOLES / NUTS.
2. DO NOT OVER TIGHTEN SCREWS AND BOLTS TO AVOID STRIPPING.

STEP 3.

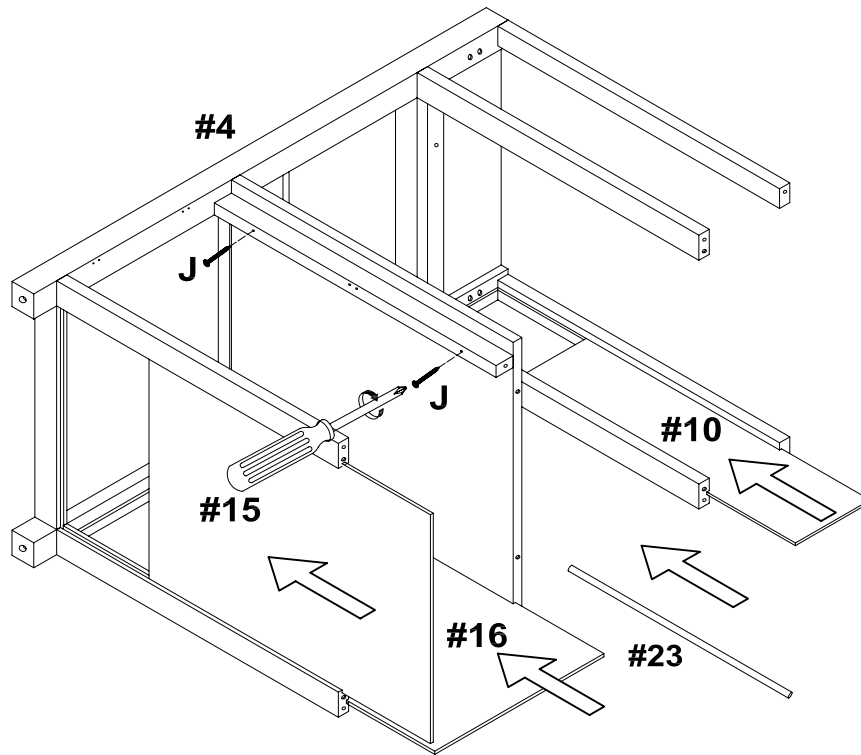

STEP 4.

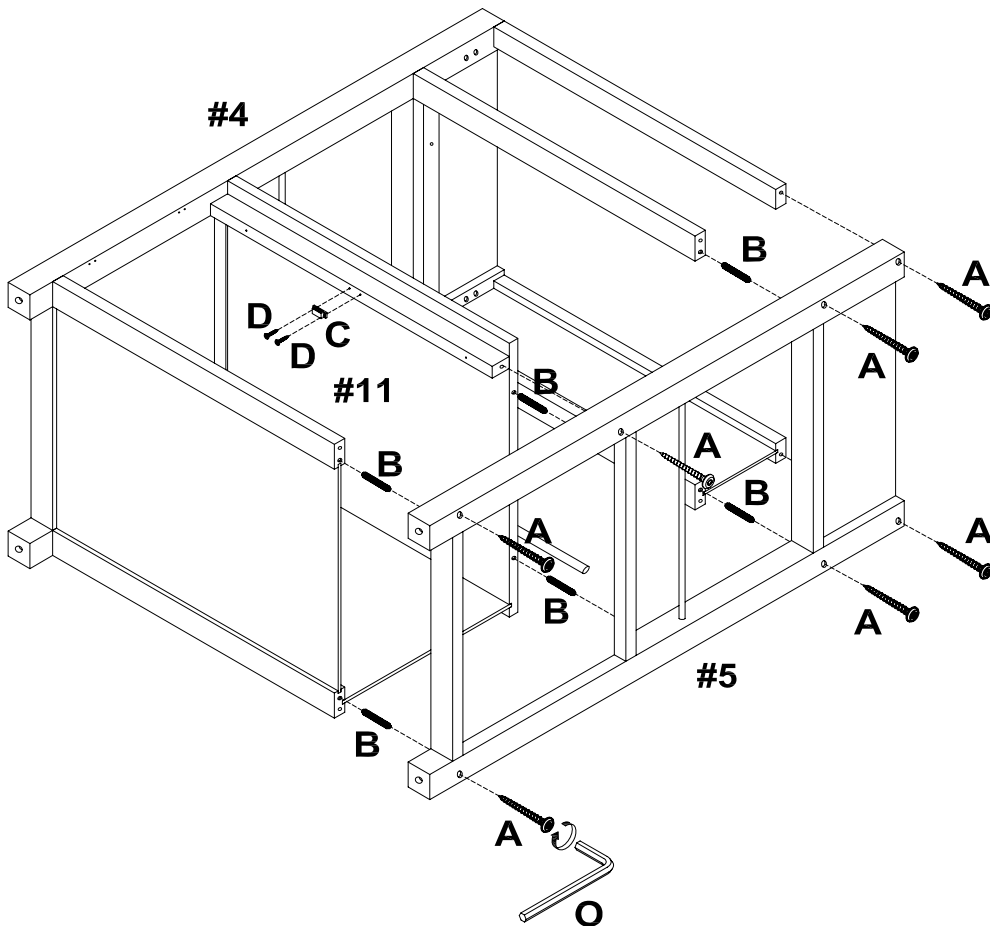

STEP 5.

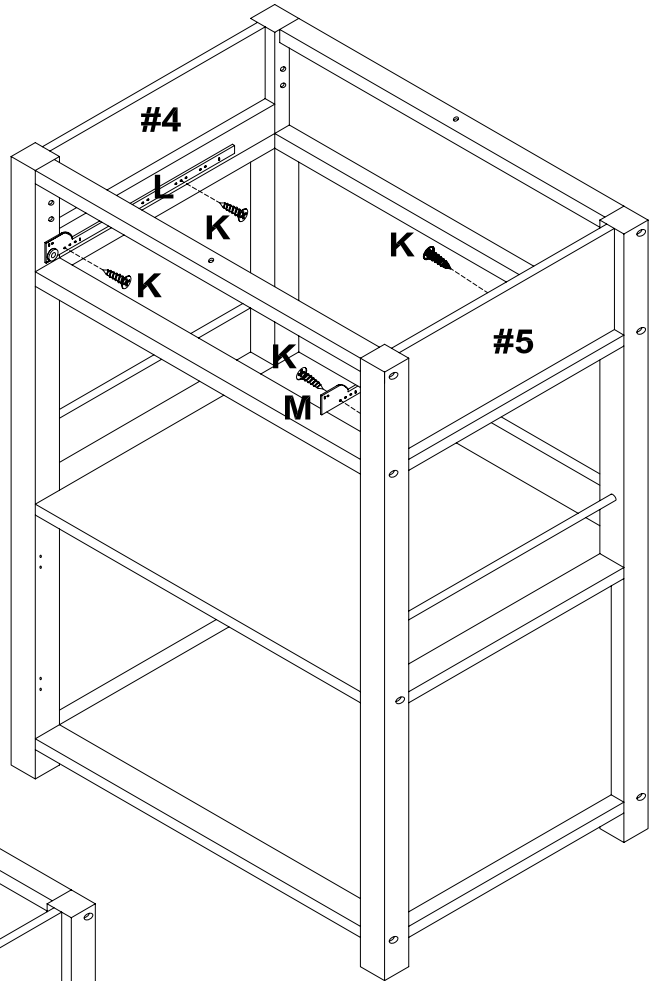
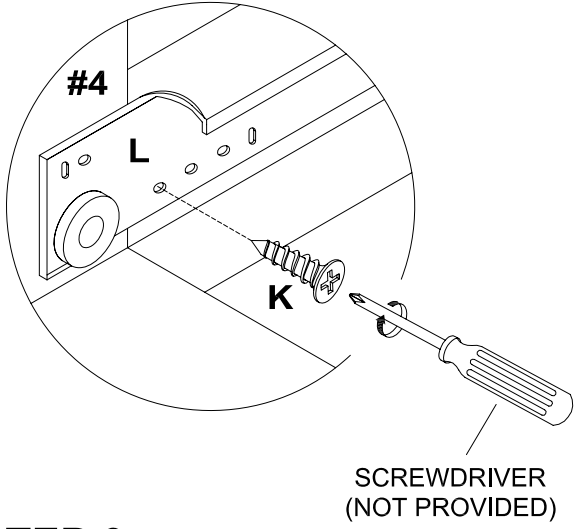

STEP 6.

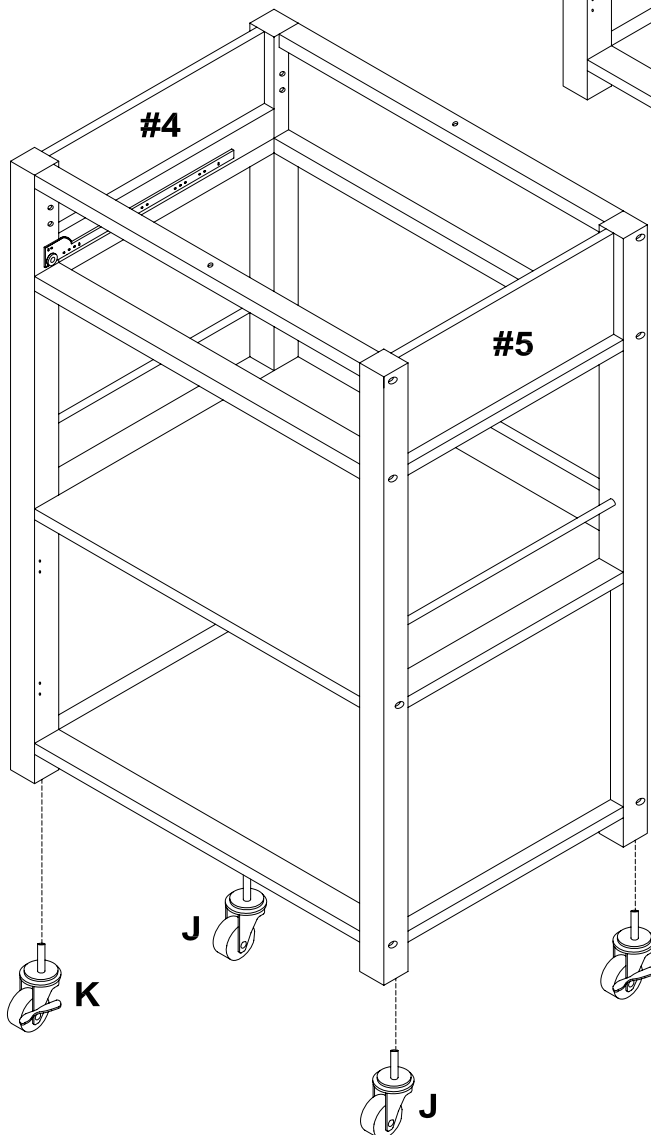

STEP 7.

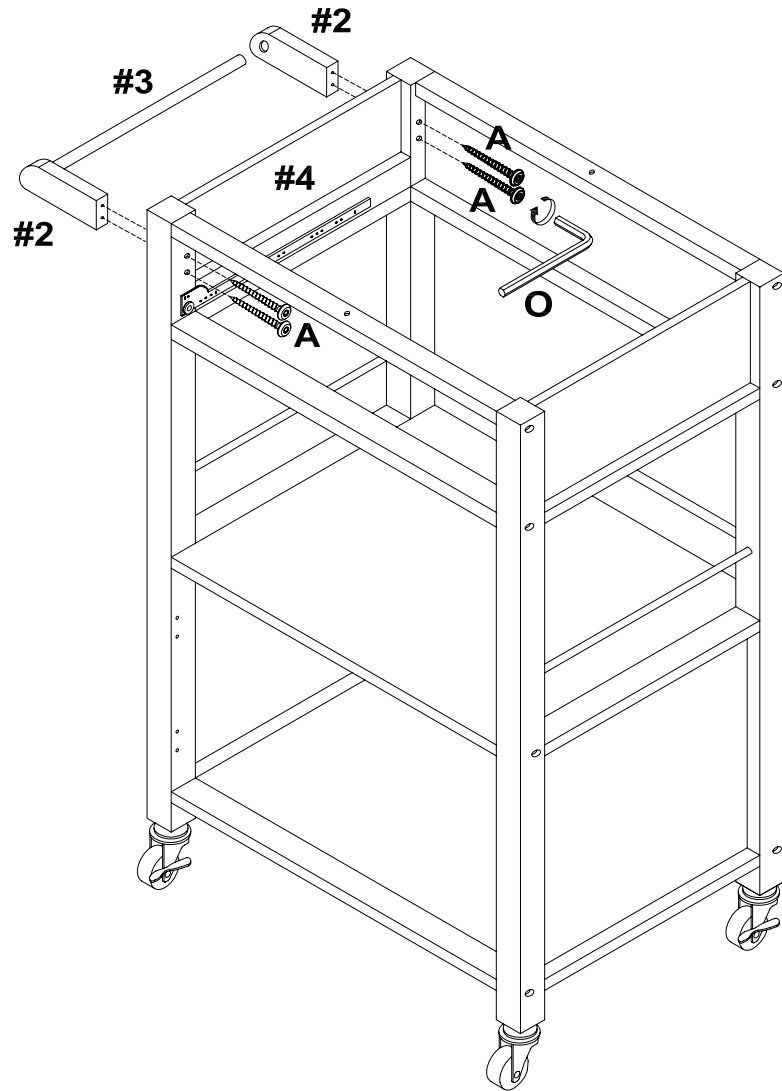

STEP 8.

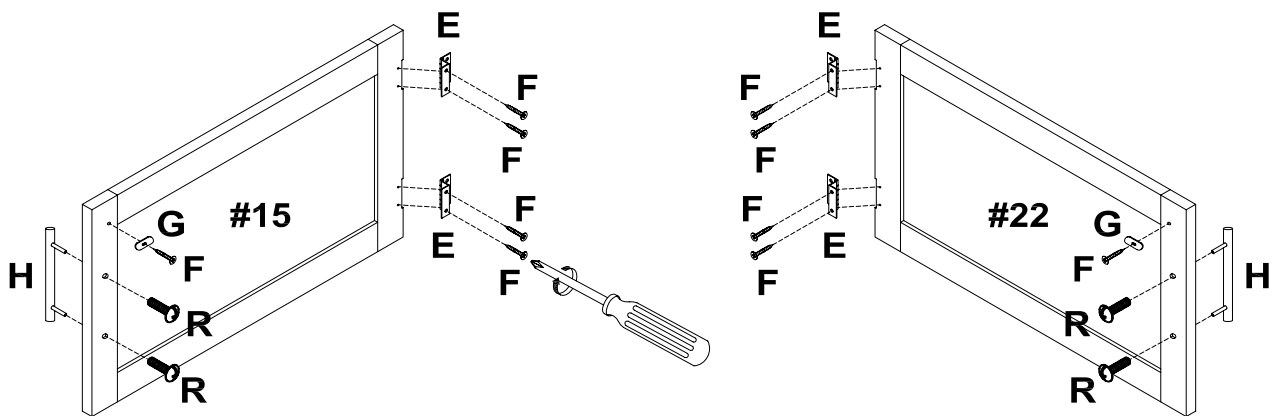

STEP 9.

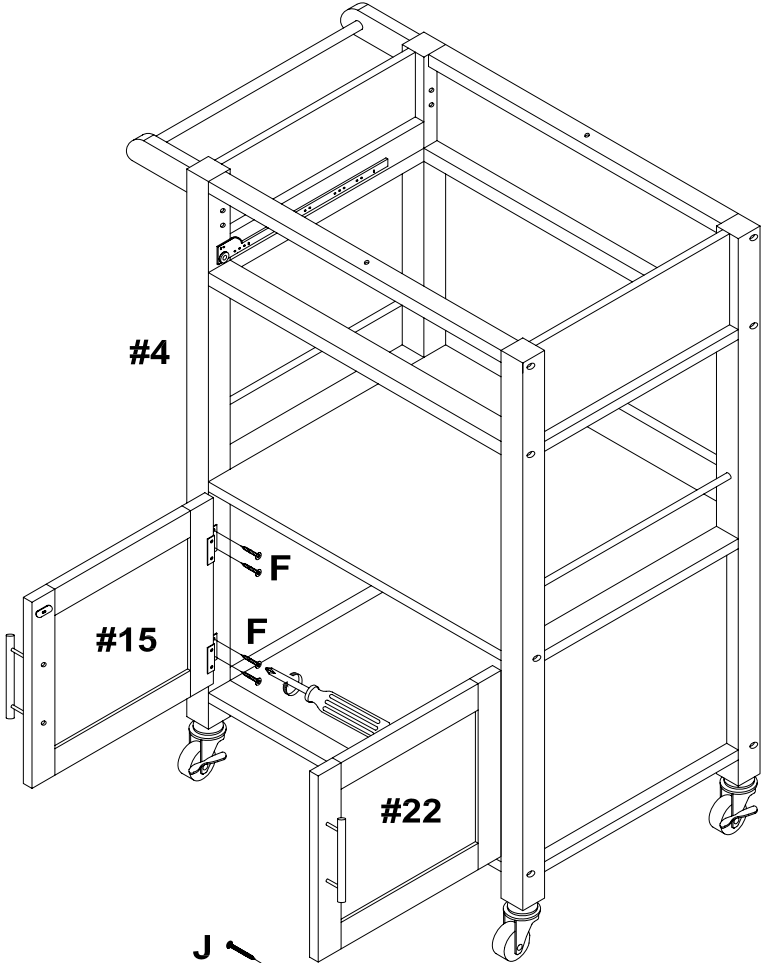

STEP 10.

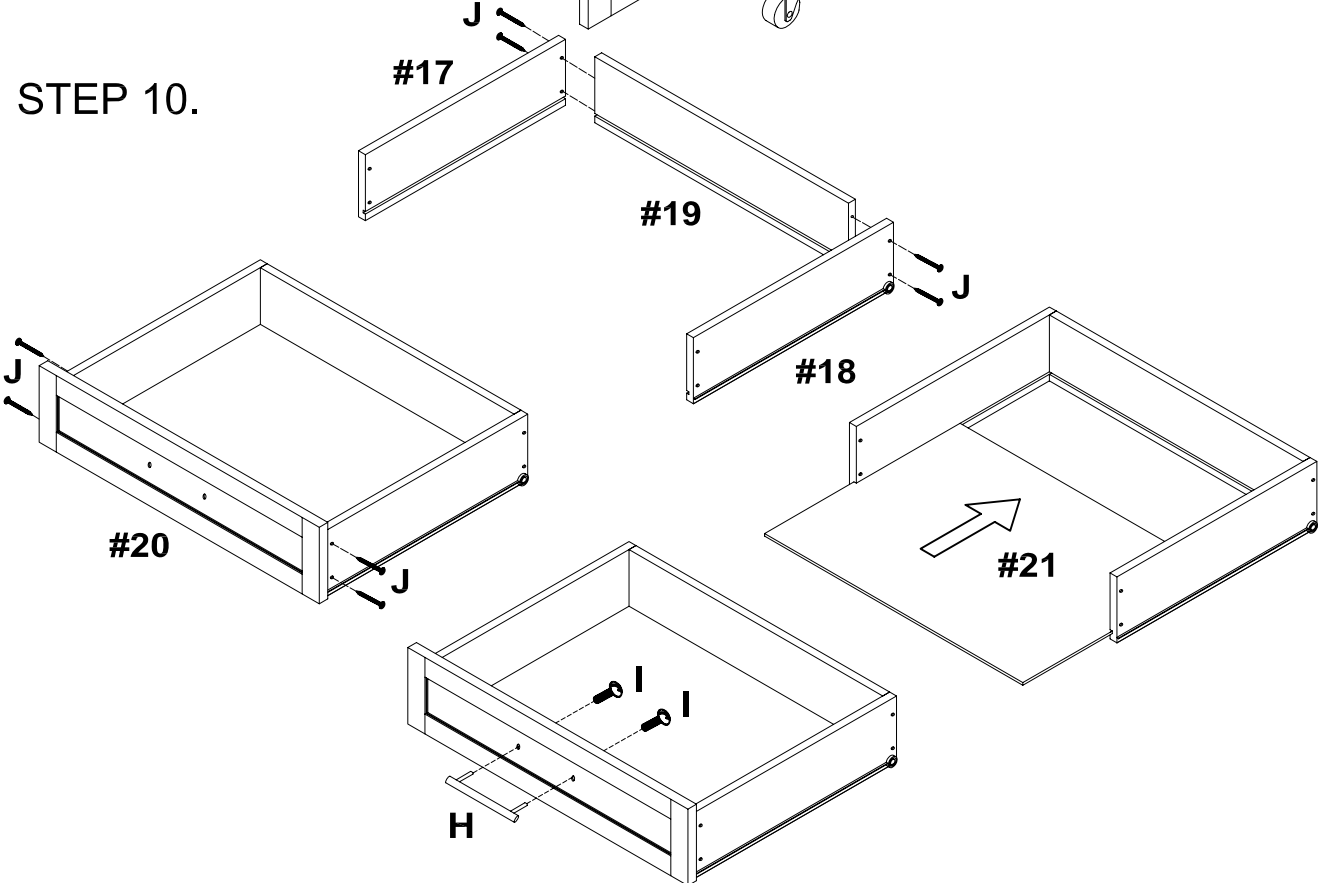

STEP 11.

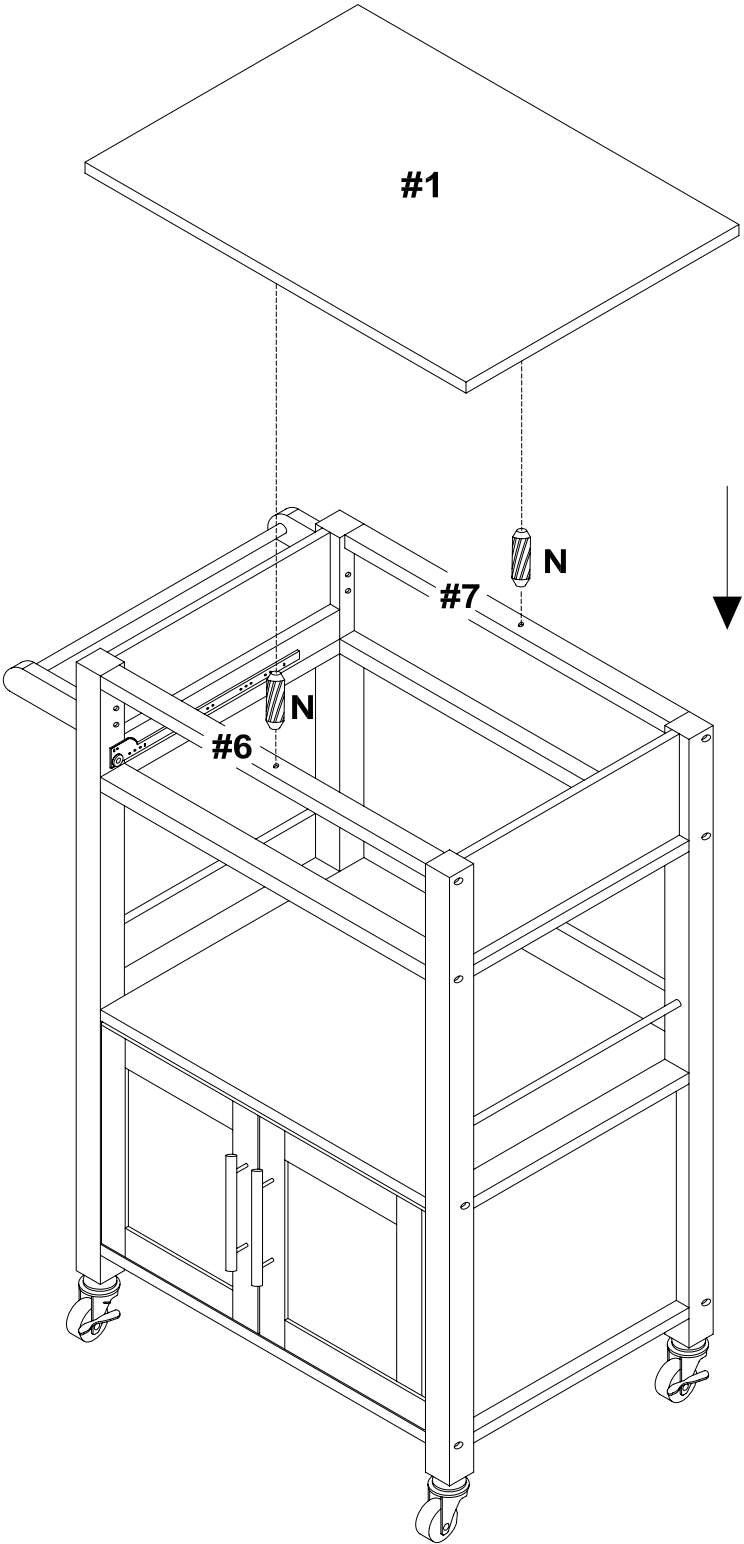

STEP 12.

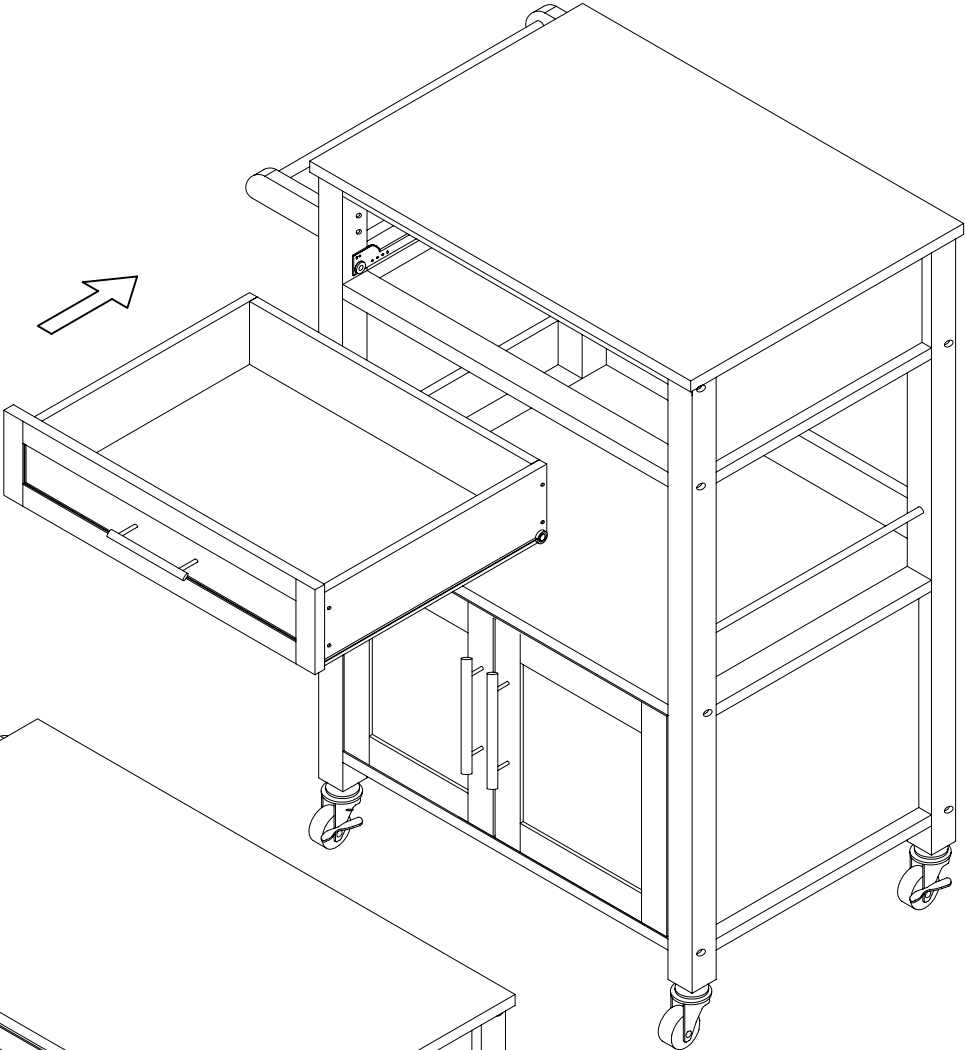

STEP 13.

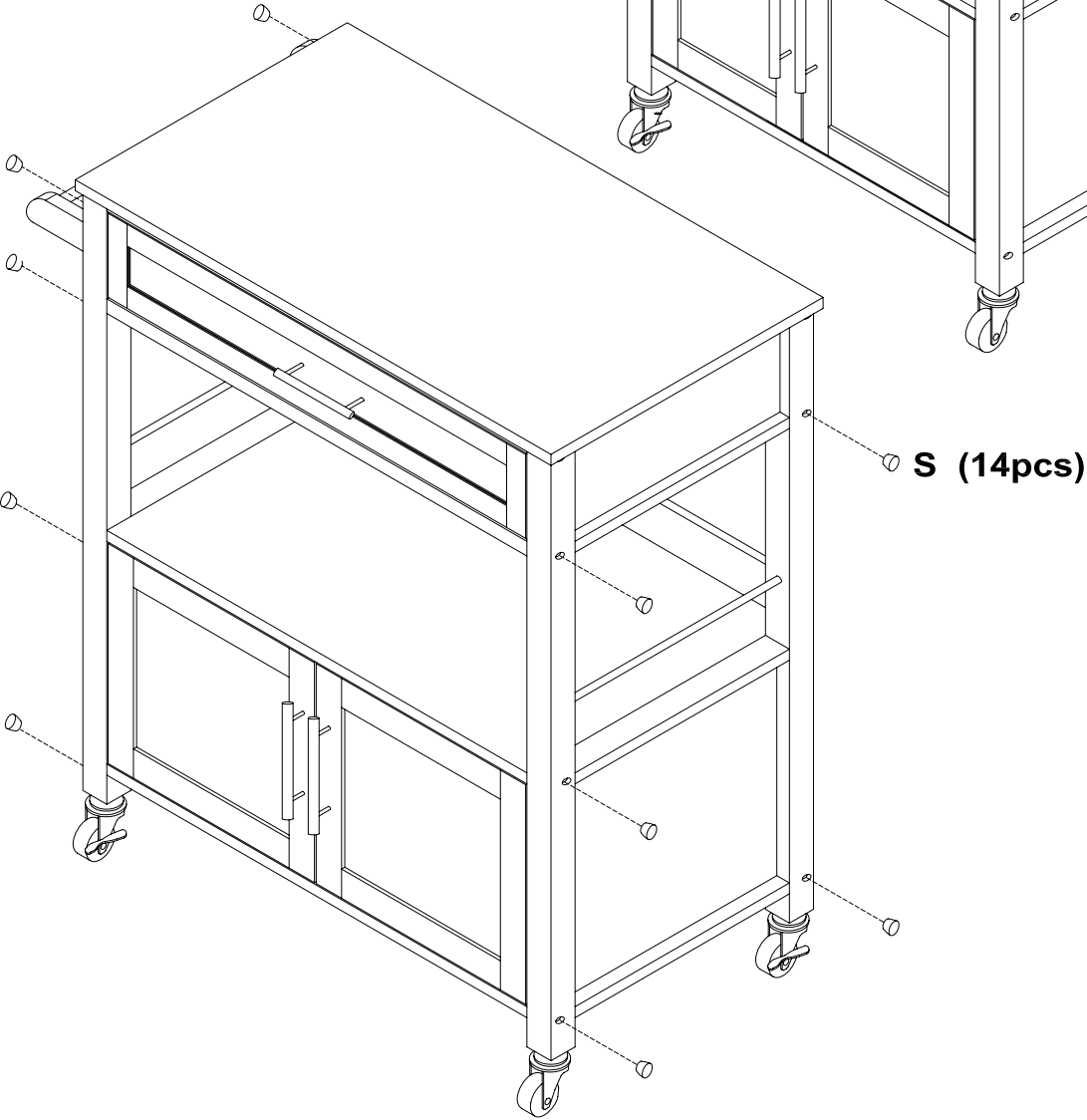

LIMITED WARRANTY
