

ASSEMBLY INSTRUCTIONS INSTRUCTIONS DE MONTAGE



IMPORTANT NOTE :

- ① PLACE ALL PARTS ON A CLEAN AND SMOOTH SURFACE SUCH AS A RUG OR CARPET TO AVOID THE PARTS FROM BEING SCRATCHED.
- ② BEFORE YOU BEGIN, KINDLY FOLLOW THE ASSEMBLY INSTRUCTIONS STEP BY STEP.
- ③ DO NOT TIGHTEN ALL SCREWS AND BOLTS UNTIL THIS ITEM IS FULLY SET-UP.







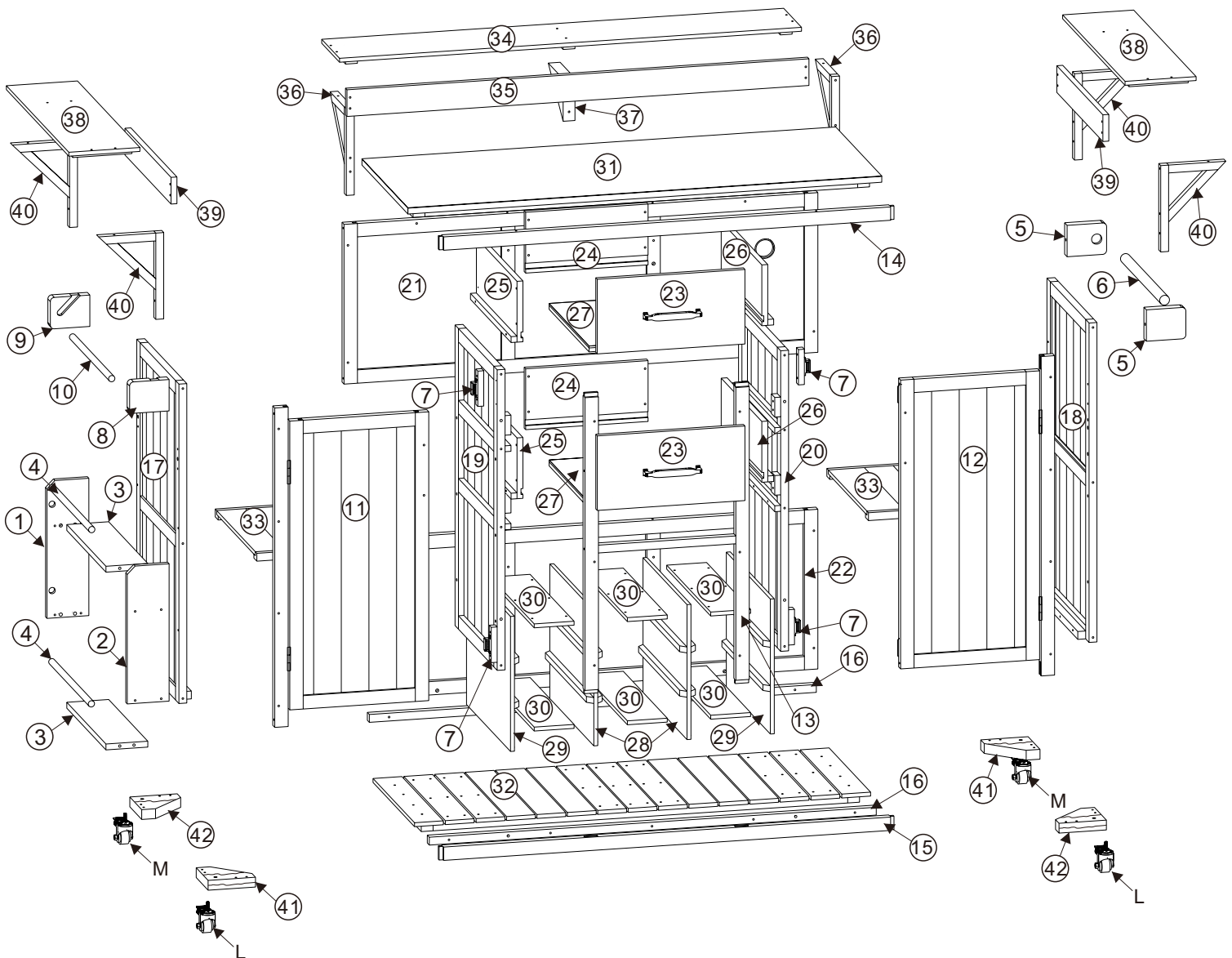









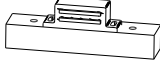

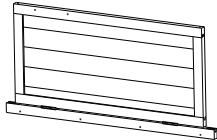

NOTE IMPORTANTE:

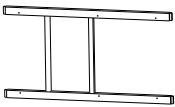

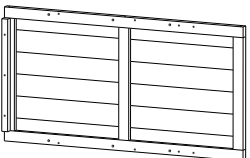
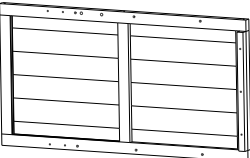
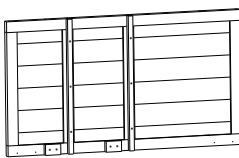
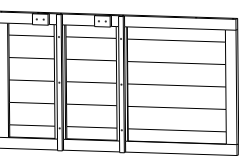
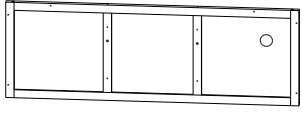
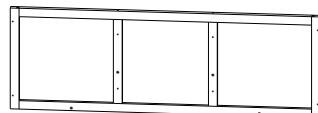
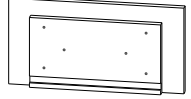

- ① PLACEZ TOUTES LES PIÈCES SUR UNE SURFACE PROPRE ET LISSE TELLE QU'UN TAPIS OU UN TAPIS POUR ÉVITER LES PIÈCES D'ÊTRE RAYÉES.
- ② AVANT DE COMMENCER, VEUILLEZ SUIVRE LES INSTRUCTIONS D'ASSEMBLAGE ÉTAPE PAR ÉTAPE.
- ③ NE SERREZ PAS TOUTES LES VIS ET LES BOULONS TANT QUE CET ARTICLE N'EST PAS ENTIÈREMENT INSTALLÉ.

Detail View Vue détaillée

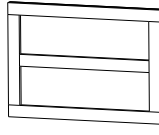
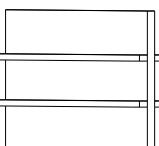
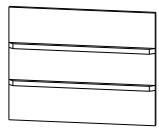
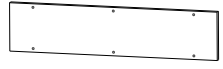
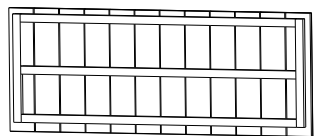
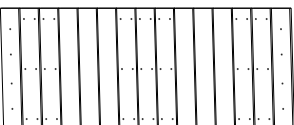

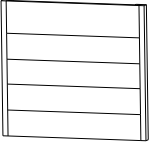
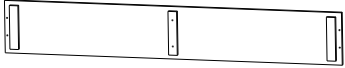
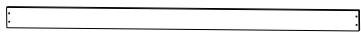

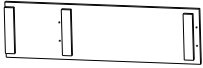

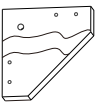
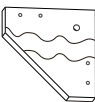

















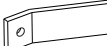



Part List Liste des pièces

1		2		3		4	
	Left panel of storage rack Panneau de rack de rangement gauche 1PC		Right panel of storage rack Panneau droit de rack de rangement 1PC		Shelf panel Panneau d'étagère 2PCS		Storage rack round rod Rack de stockage à tiges rondes 2PCS
5		6		7		8	
	Handle fixing block Bloc de fixation de poignée 2PCS		Handle round rod Poignée pour tige ronde 1PC		Magnetic wooden strip Bandes de bois magnétique 4PCS		Right tissue roll fixing block Bloc de fixation pour rouleau de papier hygiénique droit 1PC
9		10		11		12	
	Left tissue roll fixing block Bloc de fixation pour rouleau de papier hygiénique gauche 1PC		Tissue roll round rod Tige ronde pour rouleau de papier hygiénique 1PC		Left door Porte gauche 1PC		Right door Porte droite 1PC
13		14		15		16	
	Front frame Cadre avant 1PC		Upper crossbar of front panel Slat supérieur du panneau avant 1PC		Lower slat of front panel Latte inférieure du panneau avant 1PC		Front & back panel support strip Bande de support pour panneau avant et arrière 2PCS
17		18		19		20	
	Left side panel Panneau latéral gauche 1PC		Right side panel Panneau latéral 1PC		Left middle panel Panneau central gauche 1PC		Right middle panel Panneau central droit 1PC
21		22		23		24	
	Upper back panel Panneau arrière supérieur 1PC		Lower back panel Panneau inférieur du dos 1PC		Front panel of drawer Panneau avant du tiroir 2PCS		Back panel of drawer Panneau arrière du tiroir 2PCS
25		26		27		28	
	Left side panel of drawer Panneau latéral gauche du tiroir 2PCS		Right side panel of drawer Panneau latéral droit du tiroir 2PCS		Bottom panel of drawer Panneau inférieur du tiroir 2PCS		Vertical partition of the wine cabinet 1 Cloison verticale de l'armoire à vin 1 2PCS
29		30		31		32	
	Vertical partition of the wine cabinet 2 Cloison verticale de l'armoire à vin 2 2PCS		Horizontal board of the wine cabinet Planche horizontale de l'armoire à vin 6PCS		Table top Dessus de table 1PC		Bottom panel Panneau inférieur 1PC

<p>33</p> 	<p>34</p> 	<p>35</p> 	<p>36</p> 
<p>Shelf Étagère 2PCS</p>	<p>Storage rack panel 1 Panneau pour rayonnage de stockage 1 1PC</p>	<p>Vertical board of the storage rack 1 Panneau vertical du rayonnage de stockage 1 1PCS</p>	<p>Tripod 1 Trépied 1 2PCS</p>
<p>37</p> 	<p>38</p> 	<p>39</p> 	<p>40</p> 
<p>Triangular block Bloc triangulaire 1PC</p>	<p>Storage rack panel 2 Panneau pour rayonnage de stockage 2 2PCS</p>	<p>Vertical board of the storage rack 2 Panneau vertical du rayonnage de stockage 2 2PCS</p>	<p>Tripod 2 Trépied 2 4PCS</p>
<p>41</p> 	<p>42</p> 		
<p>Base 1 2PCS</p>	<p>Base 2 2PCS</p>		

Hardware List
Liste du matériel

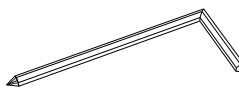
<p>A</p>  <p>3.5*60 Ph zinc screws Vis de zinc ph 8+1 pcs</p>	<p>B</p>  <p>3.5*40 Ph zinc screws Vis de zinc ph 51+1 pcs</p>	<p>C</p>  <p>3.0*35 Ph zinc screws Vis de zinc ph 30+1 pcs</p>	<p>D</p>  <p>3.0*30 Ph zinc screws Vis de zinc ph 46+1 pcs</p>
<p>E</p>  <p>3.0*25 Ph zinc screws Vis de zinc ph 12+1 pcs</p>	<p>F</p>  <p>3.0*20 Ph zinc screws Vis de zinc ph 36+1 pcs</p>	<p>G</p>  <p>3.0*16 Ph zinc screws Vis de zinc ph 24+1 pcs</p>	<p>H</p>  <p>3.0*12 Ph zinc screws Vis de zinc ph 8+1 pcs</p>
<p>I</p>  <p>M6*25 Ph zinc bolt Boulon de zinc ph 2+1 pcs</p>	<p>J</p>  <p>M4*35 Ph zinc bolt Boulon de zinc ph 4+1 pcs</p>	<p>K</p>  <p>M4*25 Ph zinc bolt Boulon de zinc ph 4+1 pcs</p>	<p>L</p>  <p>Brake wheel Roue de frein 2pcs</p>
<p>M</p>  <p>Fixed wheel Roue fixe 2pcs</p>	<p>N</p>  <p>Wood dowel Cheville à bois 32+2 pcs</p>	<p>O</p>  <p>Drawer stopper Butée de tiroir 4pcs</p>	<p>P</p>  <p>Laminated nail Clou laminé 8pcs</p>
<p>Q</p>  <p>Door handle Poignée de porte 4pcs</p>	<p>R</p>  <p>Pull box Boîte à tirer 1pc</p>	<p>S</p>  <p>Bottle opener Ouvre-bouteille 1pc</p>	<p>T</p>  <p>Angle steel Cornière en acier 6pcs</p>
<p>U</p>  <p>Open-end Wrench Clé à fourche 1pcs</p>	<p>W</p>  <p>3.0*10 Ph zinc screws Vis de zinc ph 2+1 pcs</p>	<p>V</p>  <p>S Hook S Crochet 5pcs</p>	<p>X</p>  <p>L shape metal Métal en forme de L 2pcs</p>
<p>Y</p>  <p>Ground nail Clou de sol 2pcs</p>	<p>Z</p>  <p>Connecting iron pieces Pièces de fer de connexion 2pcs</p>	<p>L shape wrench Clé en L 1pcs</p> 	

ASSEMBLY TOOLS REQUIRED(NOTINCLUDED)
OUTILS D'ASSEMBLAGE REQUIS (NON INCLUS)



PLEASE BE CAREFUL DO NOT DAMAGE THE HOLE POSITION WHEN YOU USE POWERTOOLS!

VEUILLEZ FAIRE ATTENTION À NE PAS ENDOMMAGER LA POSITION DU TROU LORS DE L'UTILISATION D'OUTILS ÉLECTRIQUES!

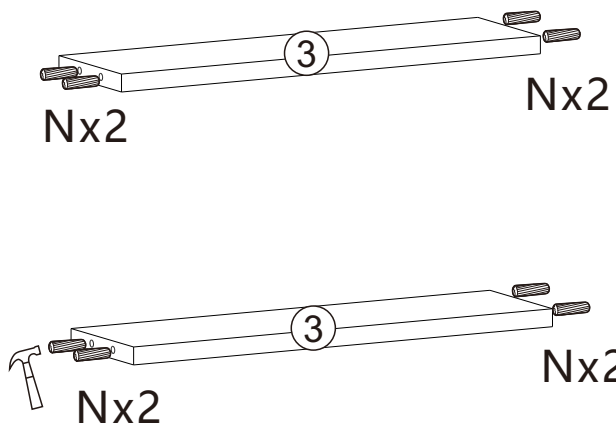

1

$N \times 8$ (3) $\times 2$

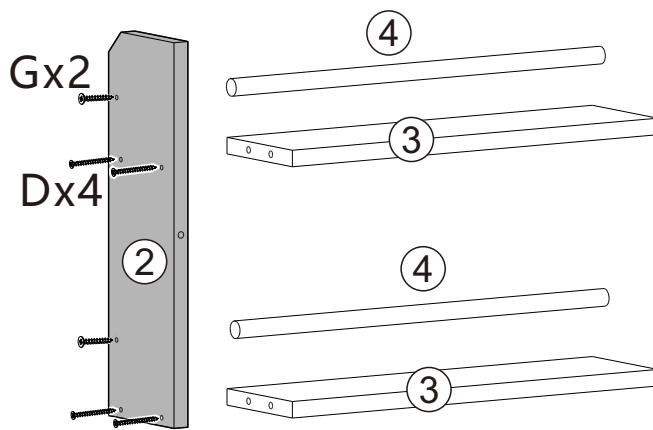

2

$D \times 4$ $G \times 2$ (2) $\times 1$ (3) $\times 2$ (4) $\times 2$

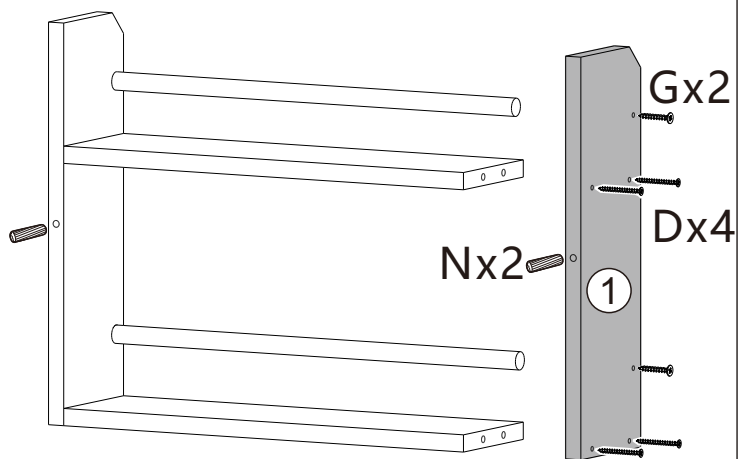

3

$D \times 4$ $G \times 2$ $N \times 2$ (1) $\times 1$

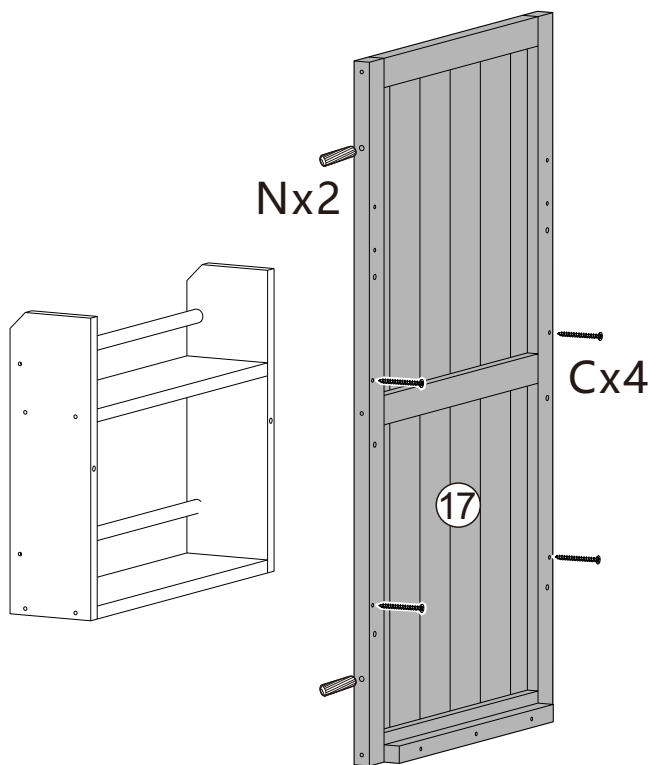

4

$C \times 4$ $N \times 2$ (17) $\times 1$

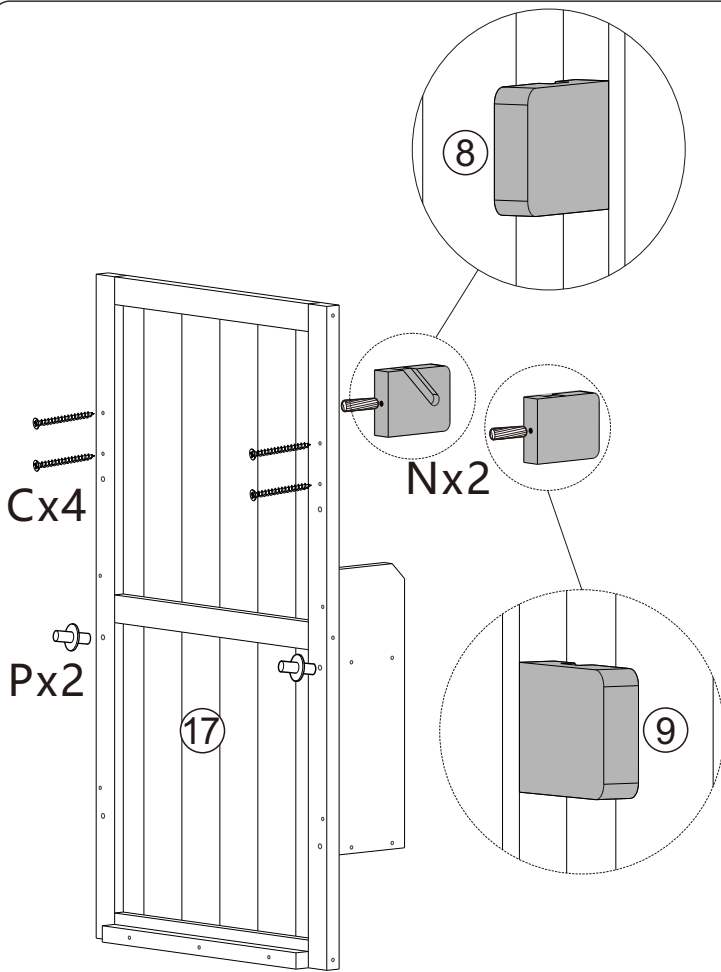

5 Cx4 Nx2 Px2 8 x1 9 x1 17 x1

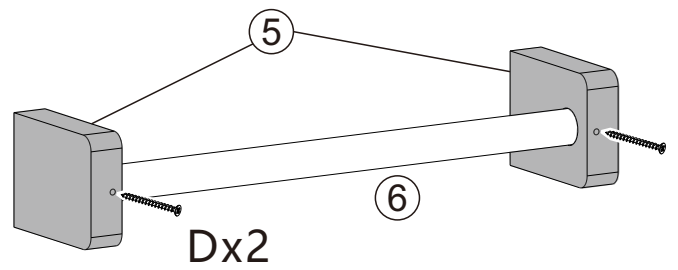

6 Dx2 5 x2 6 x1

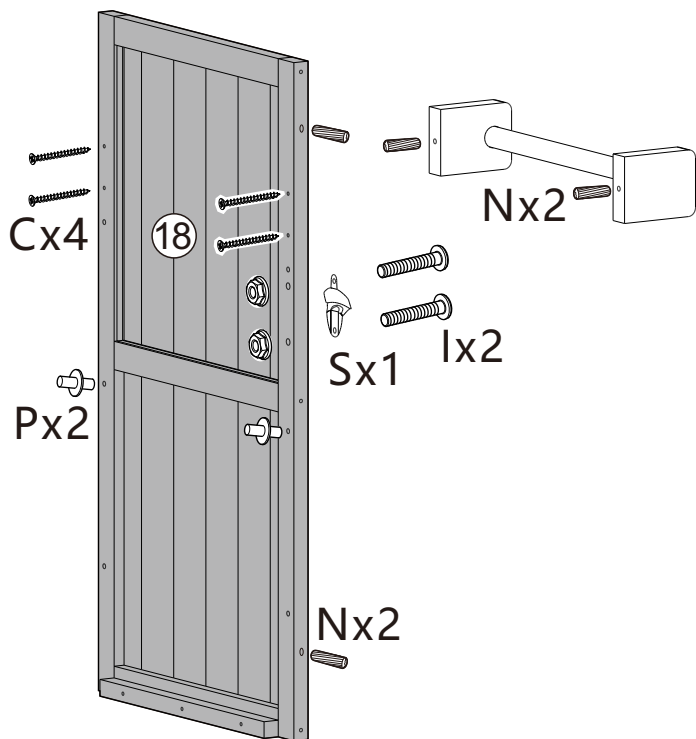

7 Cx4 Ix2 Nx4 Px2 Sx1 18 x1

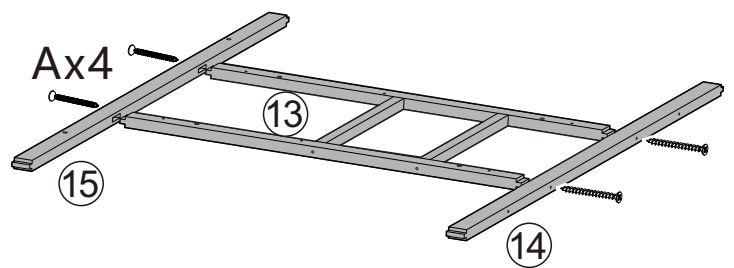

8 Ax4 13 x1 14 x1 15 x1

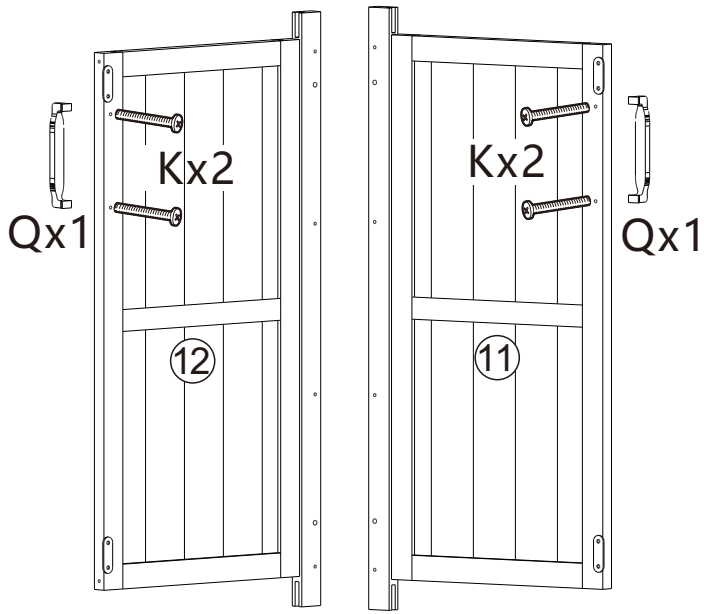

9

$Kx4$ $Qx2$ $(11)x1$ $(12)x1$

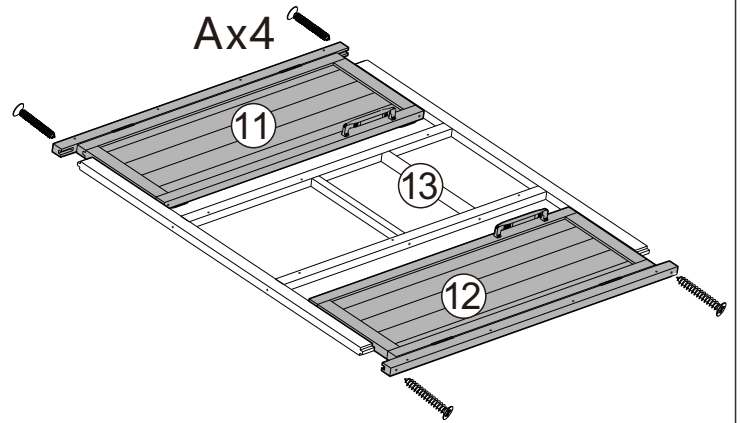

10

$Ax4$ $(11)x1$ $(12)x1$

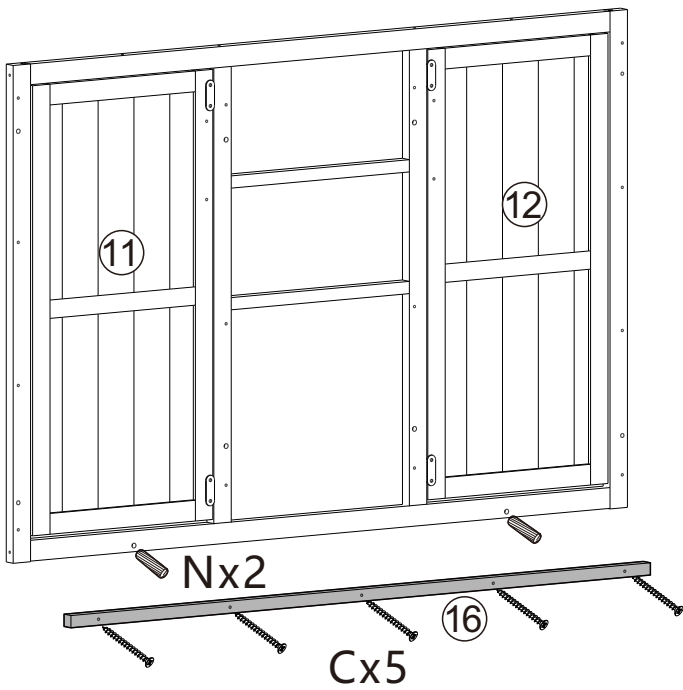

11

$Cx5$ $Nx2$ $(16)x1$

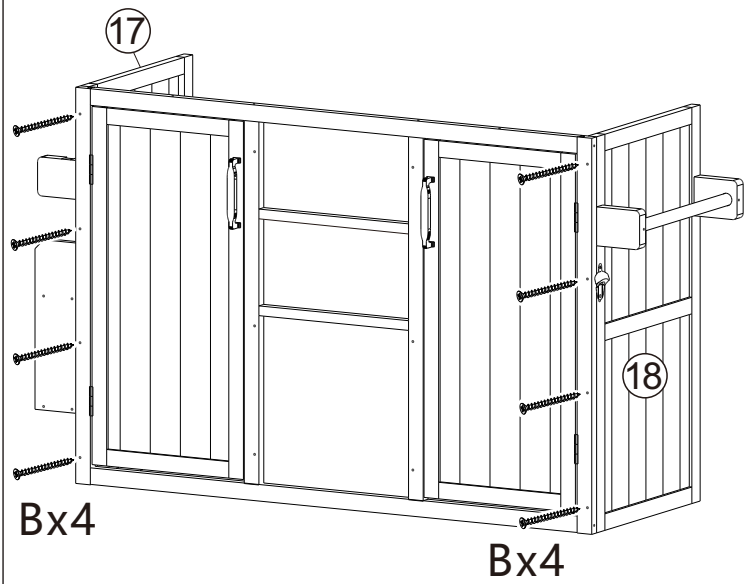

12

$Bx8$

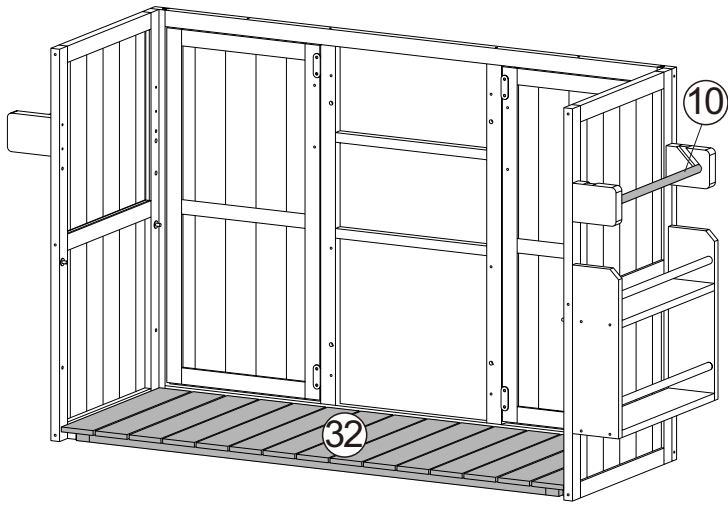

13

10 x1 32 x1

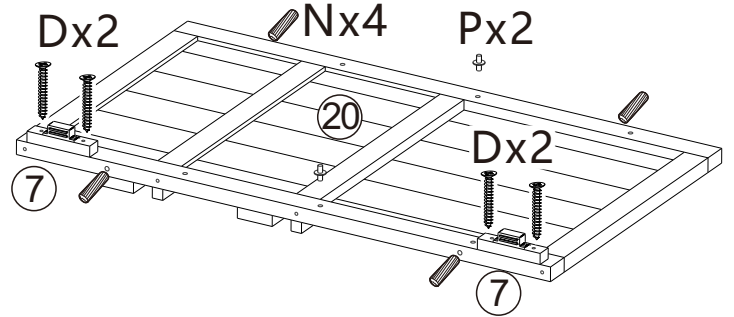
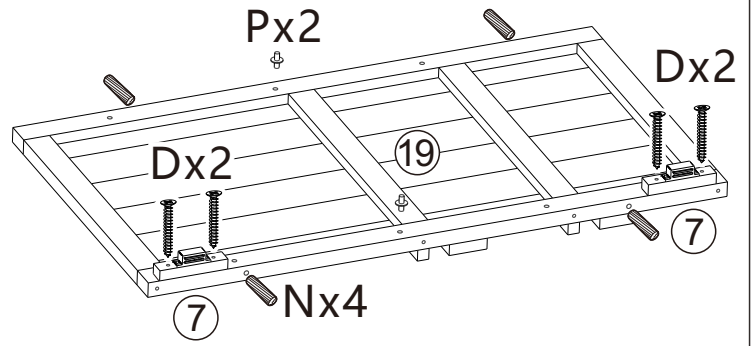

14

Dx8 Px4 Nx8 7 x4 19 x1 20 x1

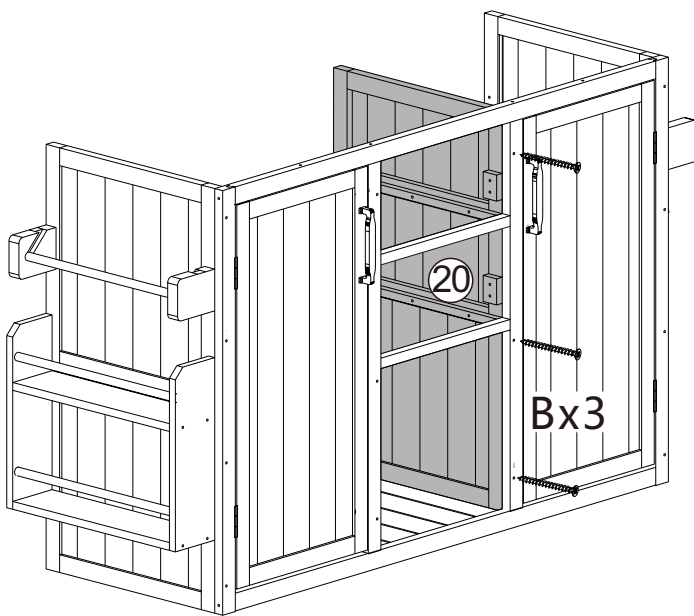

15

Bx3 20 x1

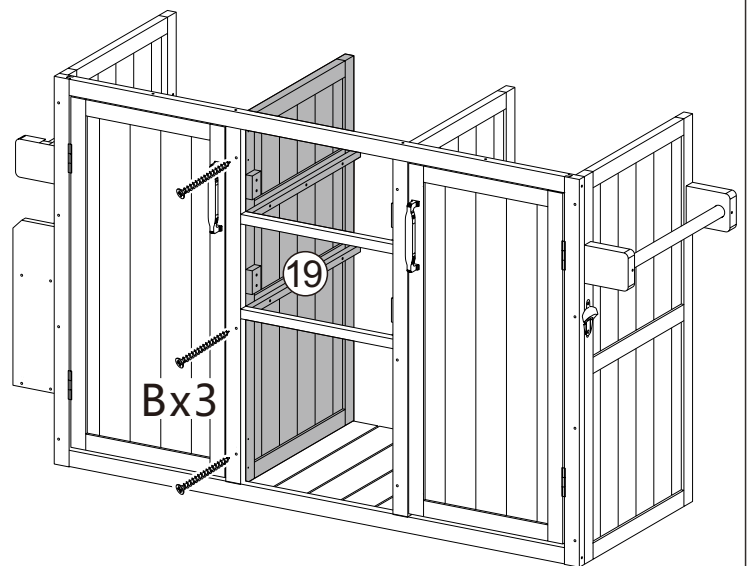

16

Bx3 19 x1

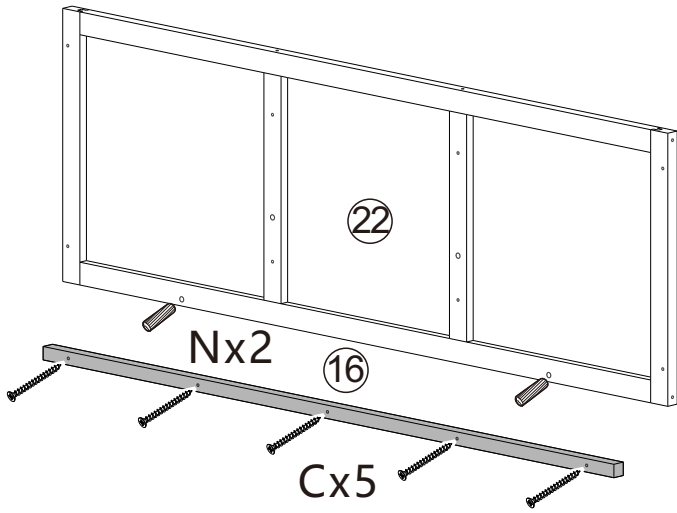

17

Cx5 Nx2 (22)x1 (16)x1

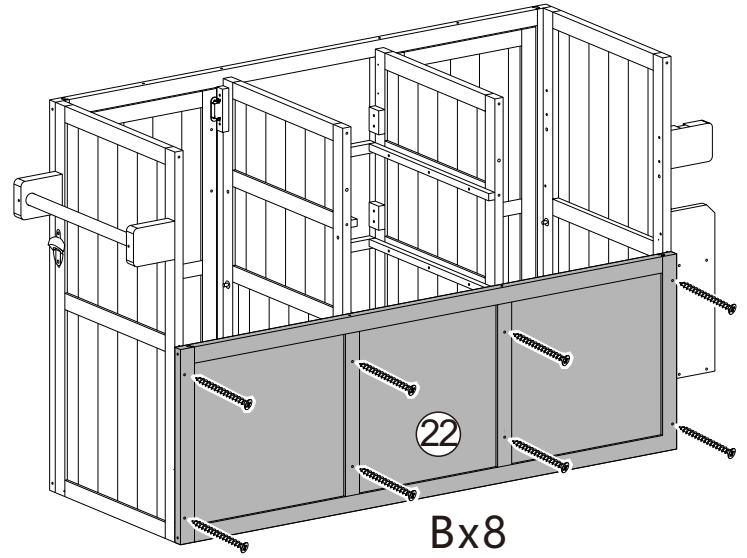

18

Bx8 (22)x1

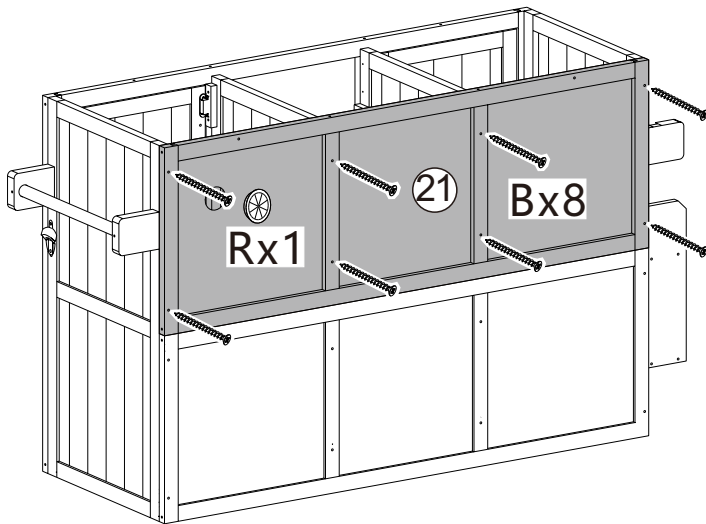

19

Bx8 Rx1 (21)x1

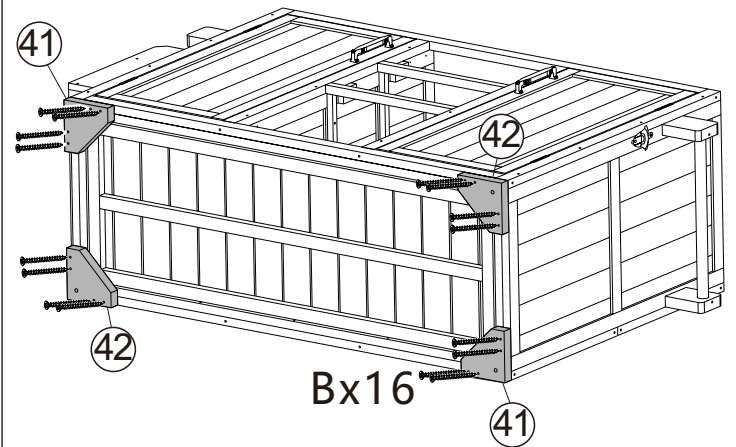

20

Bx16 (41)x2 (42)x2

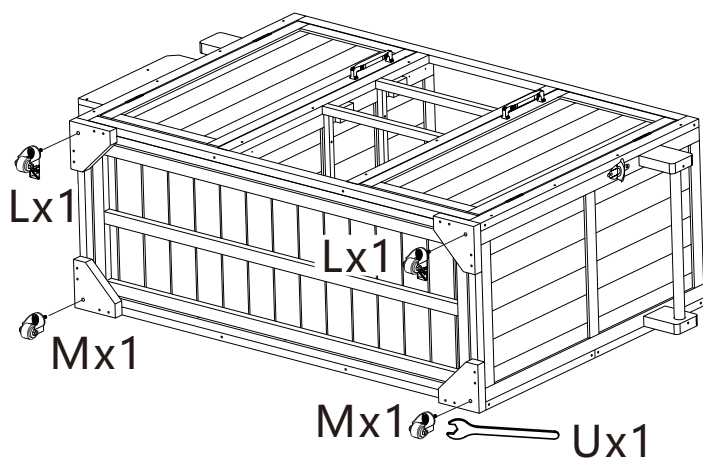

21

Lx2 Mx2 Ux1

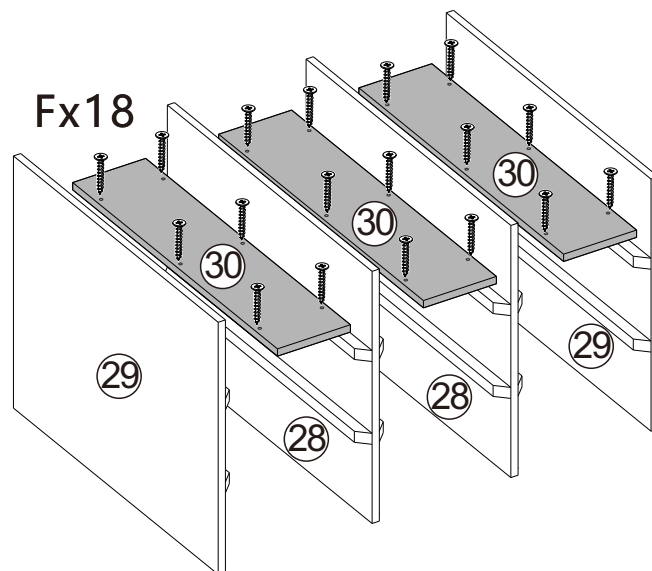

Part 30 is flush at both ends with parts 28 & 29

La pièce 30 affleure aux deux extrémités avec les pièces 28 et 29

22

Fx18 (28) x2 (29) x2 (30) x3

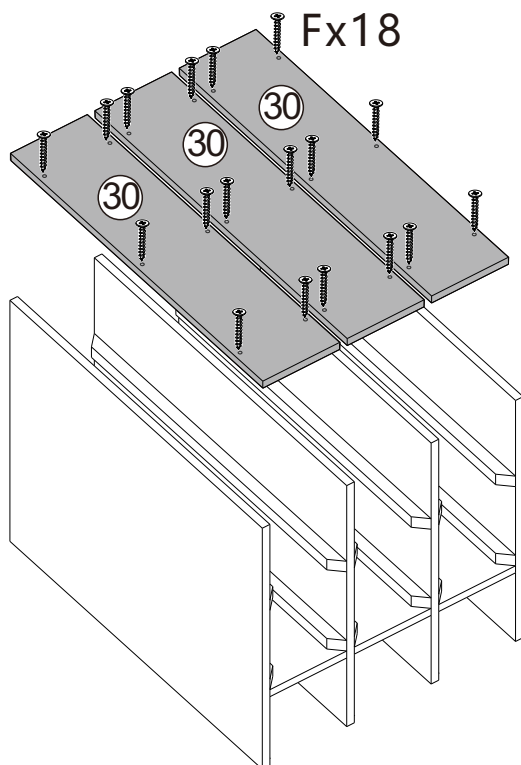

23

Fx18 (30) x3

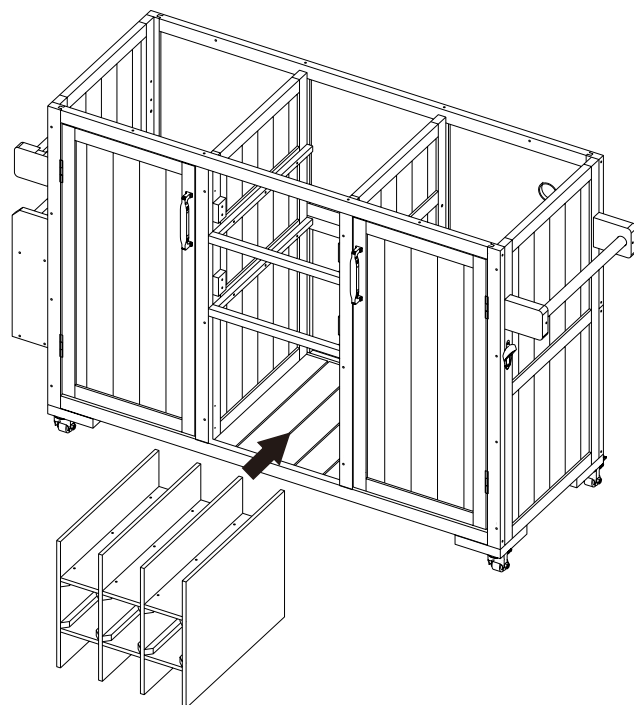

24

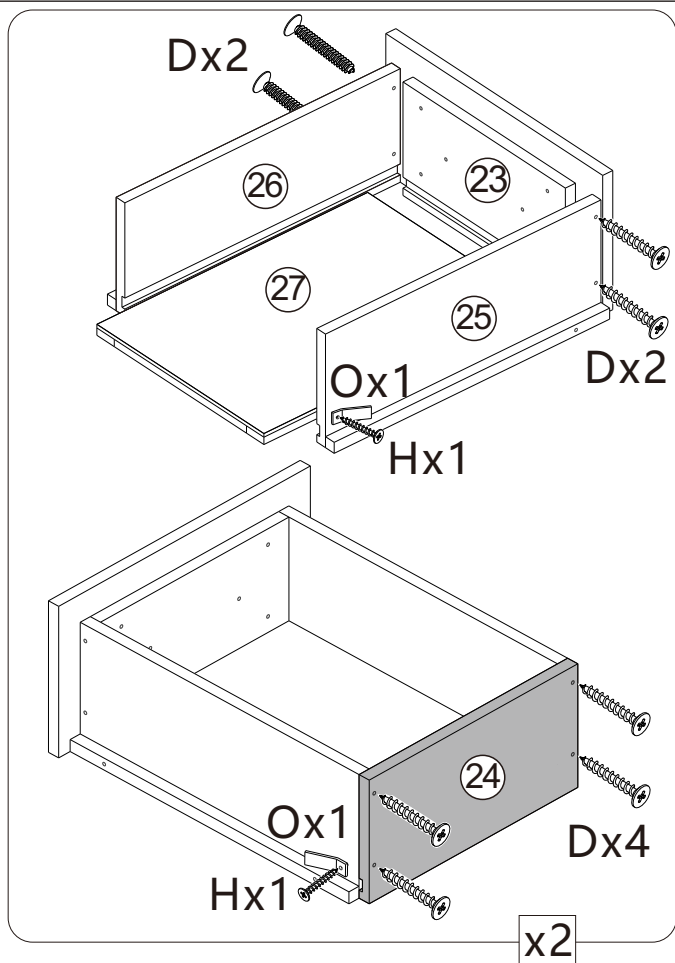

25 Dx16 Hx4 Ox4 (23) x2 (24) x2 (25) x2 (26) x2 (27) x2

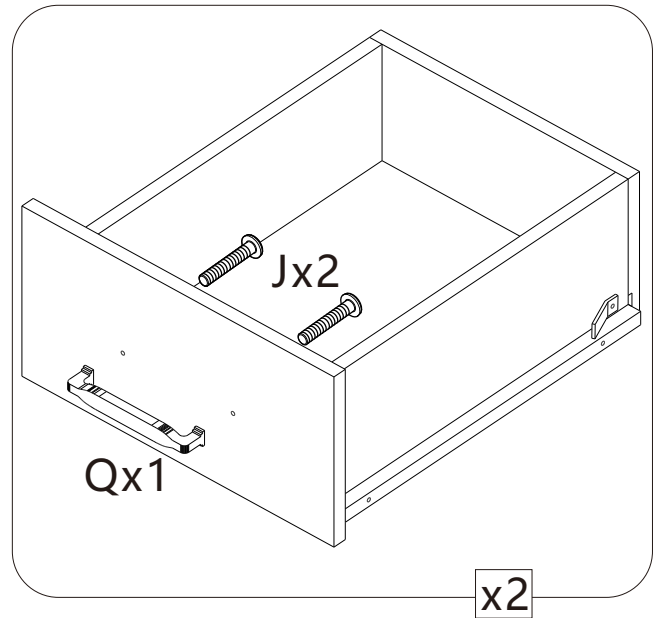

26 Jx4 Qx2

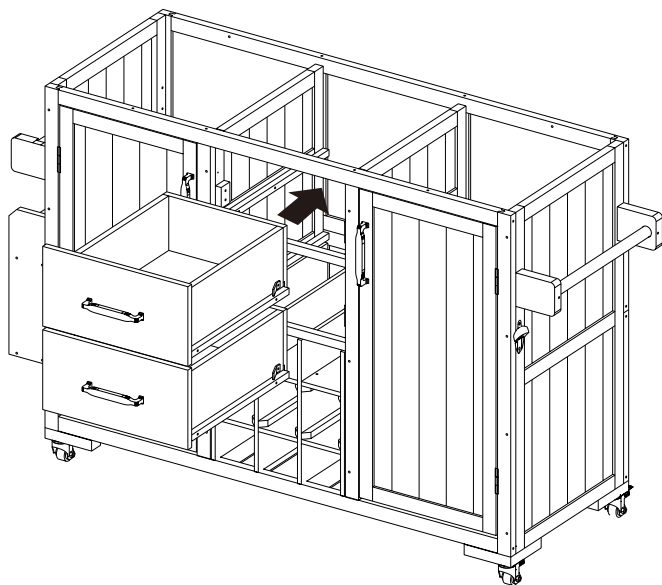

27

The stainless steel table top has a bent side on this side

Le plateau en acier inoxydable présente un bord plié de ce côté.

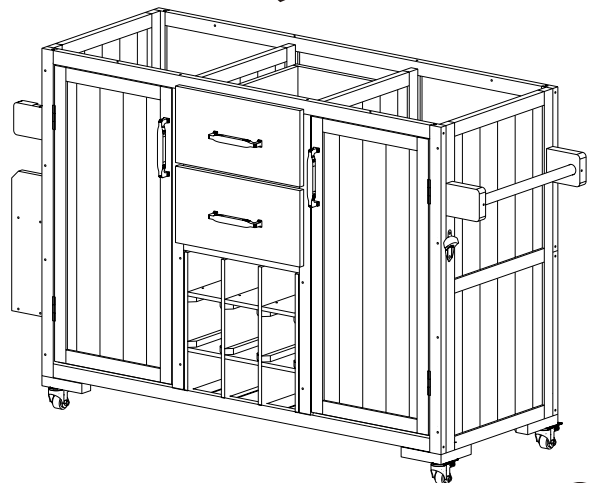
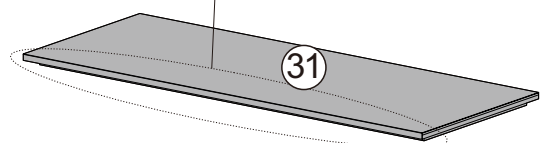

28

(31) x1

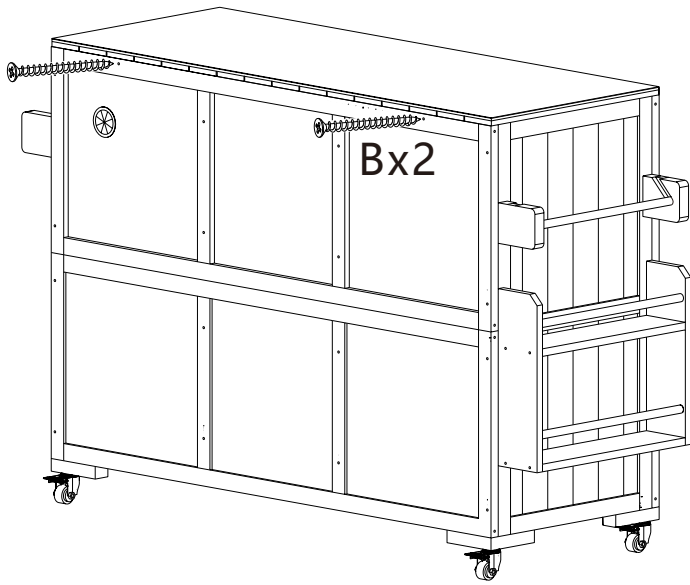

29

Bx2

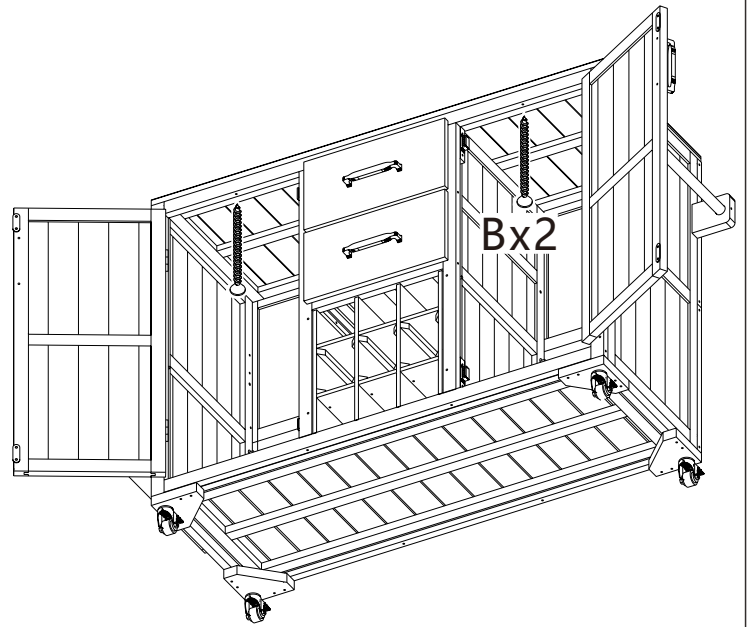

30

Bx2

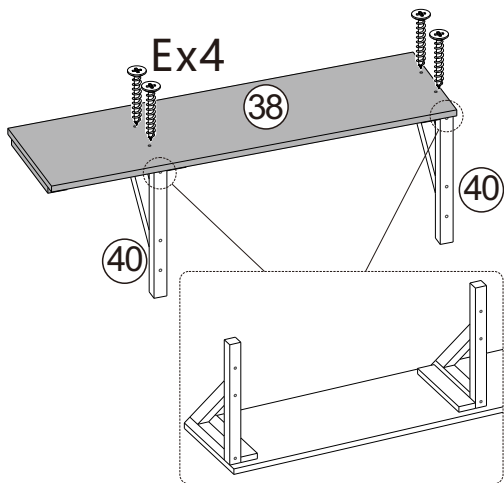

31

Dx4 Ex4 38 x1 39 x1 40 x2

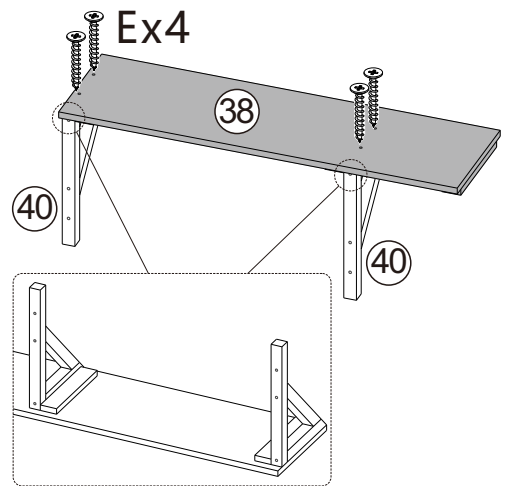

32

Dx4 Ex4 38 x1 39 x1 40 x2

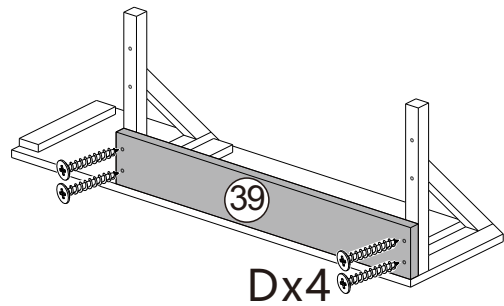
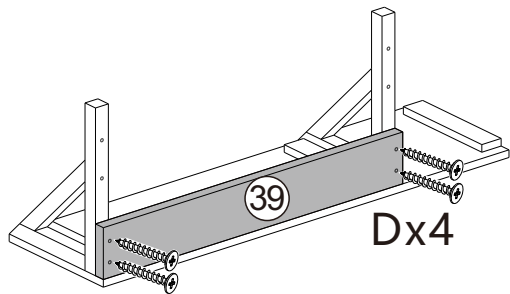

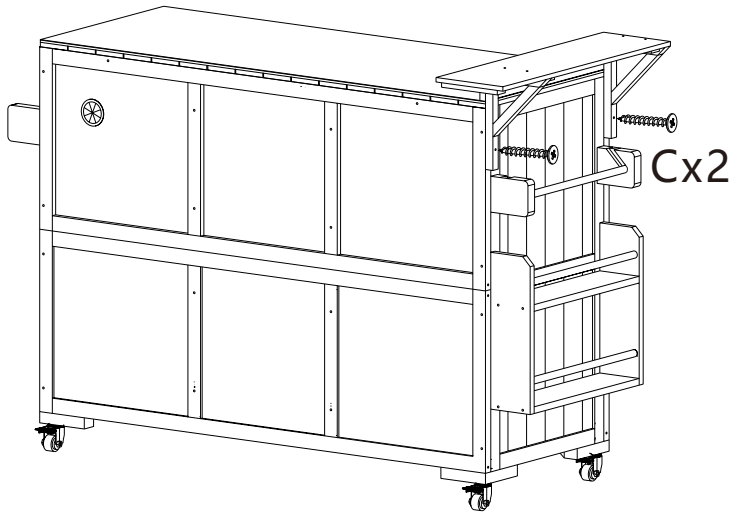

33

Cx2

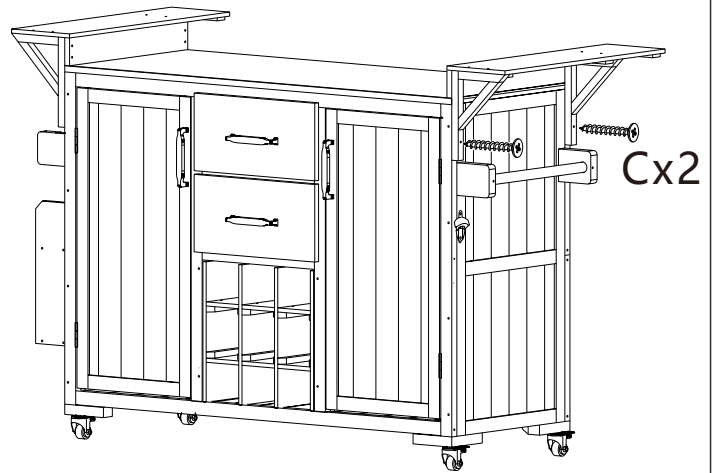

34

Cx2

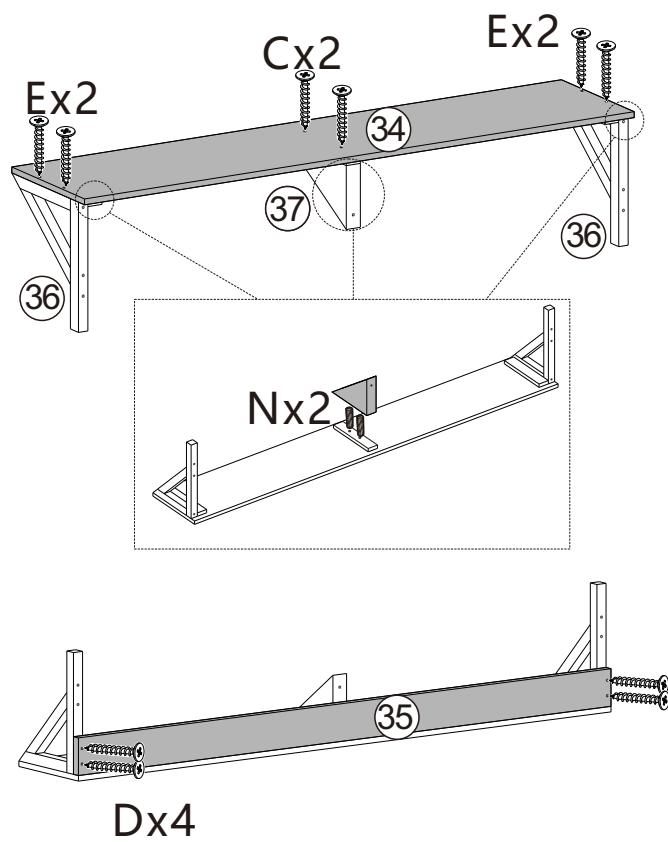

35 Cx2 Dx4 Ex4 Nx2 34 x1 35 x1 36 x2 37 x1

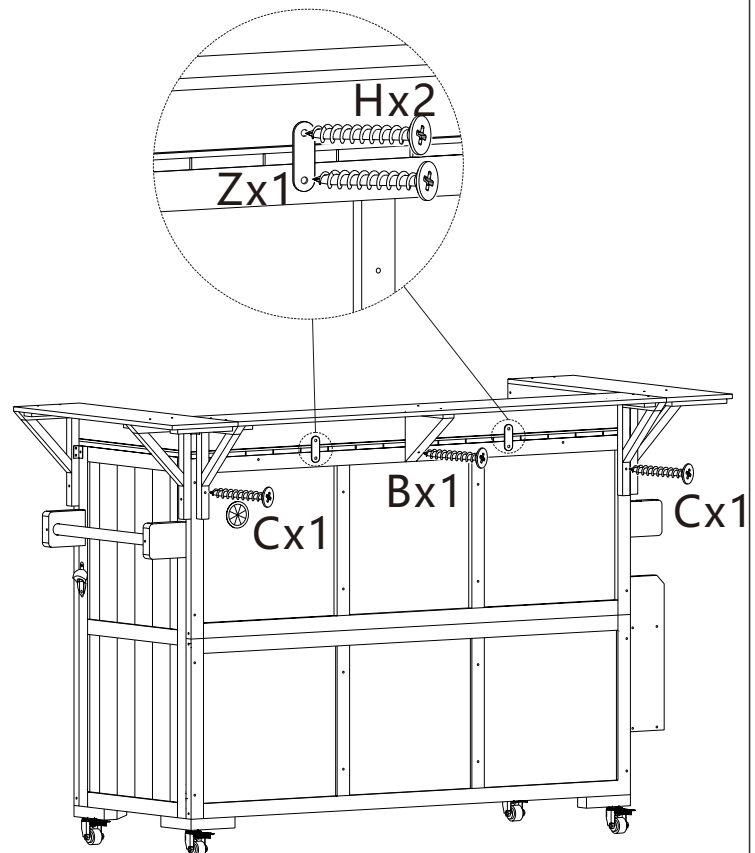

36

Bx1 Cx2 Hx4 Zx2

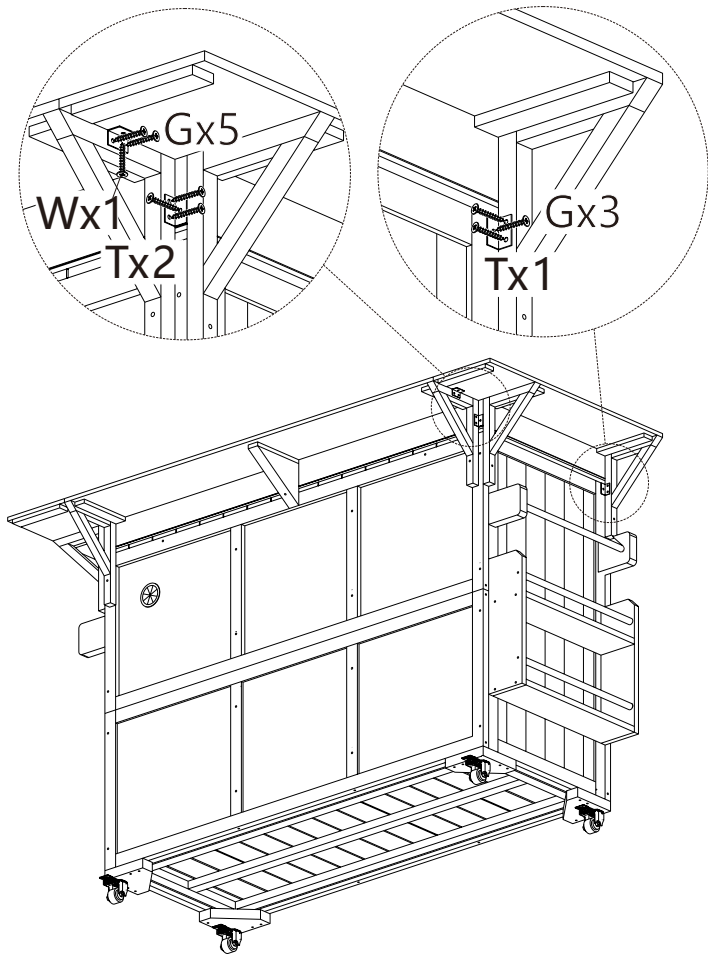

37

Tx3 Gx8 Wx1

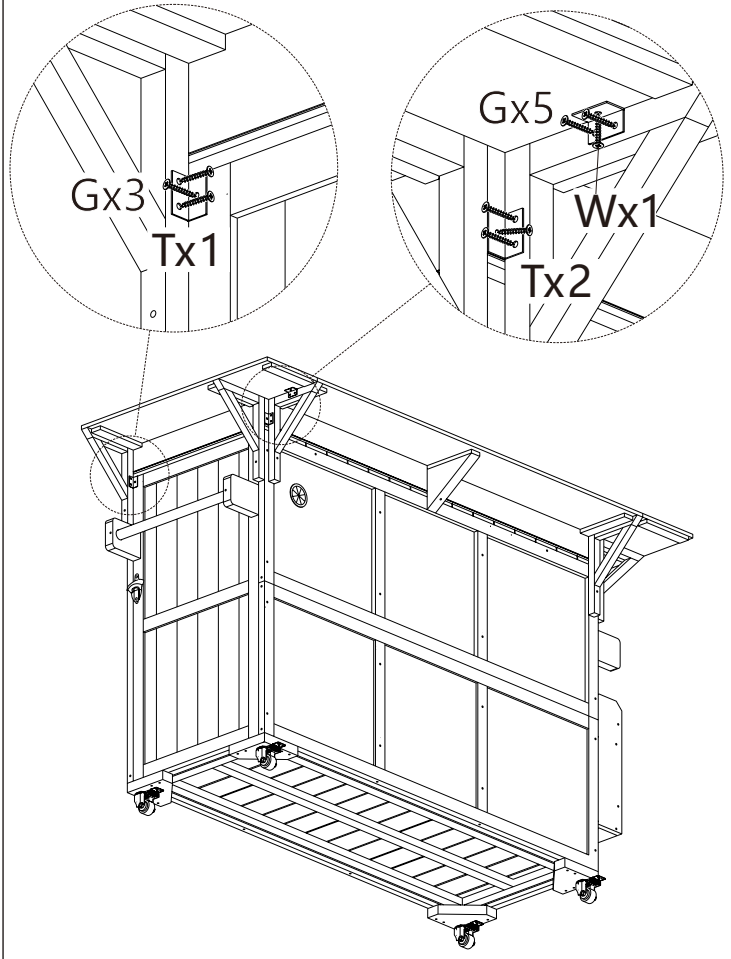

38

Tx3 Gx8 Wx1



39

33 x2

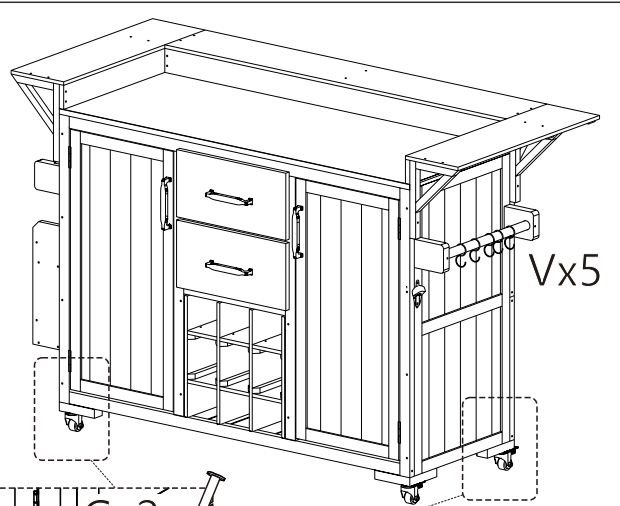

40

Gx4 Xx2 Yx2 Vx5

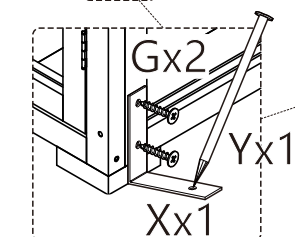

Remove 4 wheels firstly, then assembly L shape metal and nails.

Retirez 4 roues tout d'abord, puis assemblage en forme de L métal et clous