

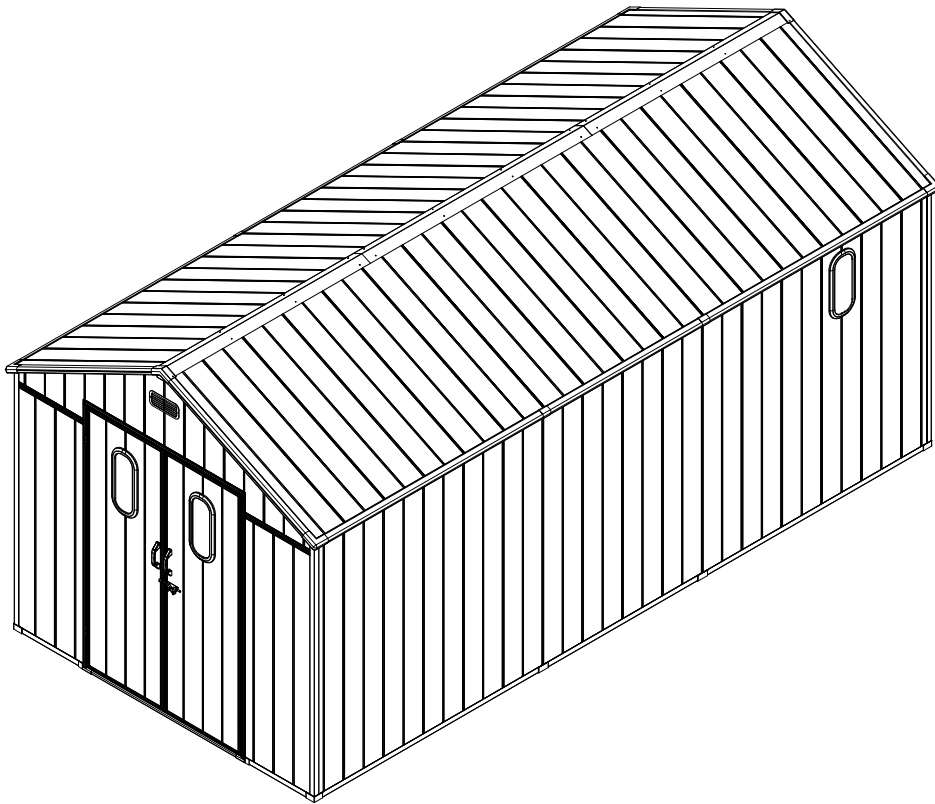

8'x16'

Outdoor Storage Shed

ASSEMBLY MANUAL



MODEL#: LGCZ1772

Missing part? Damaged? Contact us via email at

service@domioutdoorliving.com

www.domioutdoorliving.com

STOP

Missing Parts, Questions on Assembly?

Email me: service@domioutdoorliving.com

Do not return to dealer they are not
equipped to handle your requests.

We will reply to you within 1 business day.

PLAN AHEAD

Before beginning installation, check local building codes regarding footings, location and other requirements.

Study and understand this instruction.

Important information and helpful tips will make your installation easier and more enjoyable.

Tools and Materials: There are some basic tools and materials you will need for the installation. Decide which method of anchoring and the type of foundation you wish to use in order to form a complete list of the materials you will need.

BEFORE YOU BEGIN

Assembly Instruction: Instructions are supplied in this manual and contain all appropriate information for your installation. Review all instructions before you begin, and during assembly, follow the step sequence carefully for correct results.

Parts List: Check to be sure that you have all the necessary parts and quantities in your package. These are packaged within the carton. Note that extra fasteners have been supplied for your convenience.

Explosion Diagram: All parts except screws and bolts are shown in this diagram, review all parts before you begin. Familiarize yourself with the hardware and fasteners for easier use during installation.

Pre-assembly



1. Two or more people are required for assembly.



2. You will need one or more stepladders.



3. Wearing protective gloves is recommended.



4. You may need a safety hat.



5. Please use a Phillips screw driver.



6. For ease of construction, you may need a drill.



7. You may need a safety goggle.



8. Do not fully tighten screws prior to complete assembly.

Warning & Attention

-Try to assemble this product on the flat ground, otherwise it is difficult to carry out;

-It would be much easier to assemble the product with three or more people;

-Gaskets must be used.

-After assembly, please check whether all screws are tightened, to prevent parts from falling apart.

▲ Use bolts to secure the frame to the ground to against the strong wind.

👤 Please stand inside the shed frame when installing the panels for convenience.

ASSEMBLY TIPS & TOOLS

Watch the Weather Closely: Be sure the day you choose to install your building is dry and calm. Do **NOT** attempt to assemble your building on a windy day. Be careful on wet or muddy ground.

Use Teamwork: Two or more people are required to assemble your building. One person can hold the parts or panels in place while the other person fastens them together and handles the tools. This makes the process of assembling your building faster and safer.

Tools and Materials: Here is a list of some basic tools and materials you will need to assemble your building. Decide which method of anchoring and the type of base you will use to make a complete list of the materials you will need.

WHAT YOU NEED

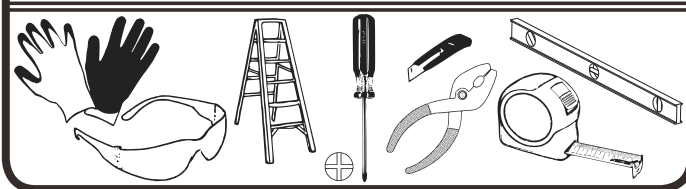

- Work Gloves
- Safety Glasses
- Step Ladder
- No. 2 Phillips Screwdriver (Magnetic Tip Preferred)
- Utility Knife or Scissors
- Pliers
- Carpenter's Level
- Tape Measure

RECOMMENDED TIME SAVERS

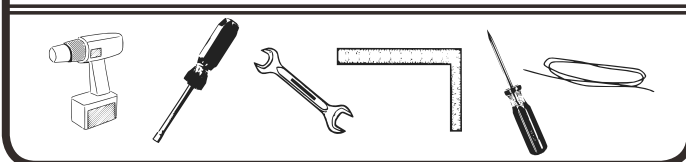

- Power Drill (Cordless, Variable Speed)
- Nut Driver or Wrench
- Square
- String (for squaring the frame)
- Awl (to align holes)

BASE PREPARATION TOOLS

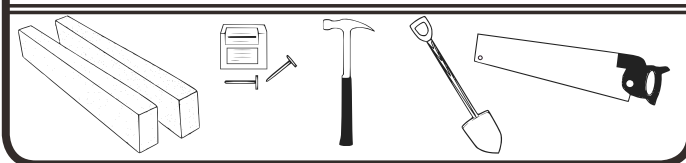

- Lumber and/or Concrete
 - Hammer and Nails
 - Spade or Shovel
 - Hand Saw or Power Saw
-
-

How to Select and Prepare Your Building Site: Before you start to assemble your building, you will want to decide on a good location. The best location is a level area with good drainage.

- Allow enough working space so it is not difficult to move parts into position for assembly. Be sure there will be enough space at the entrance for the doors to completely open. Also, there needs to be enough space outside the building to be able to fasten the panel screws from the outside.
- Before assembling any parts, your base should be constructed and an anchoring system should be ready to use.

SAFETY PRECAUTIONS...

Safety precautions MUST be followed at all times throughout the construction of your building!

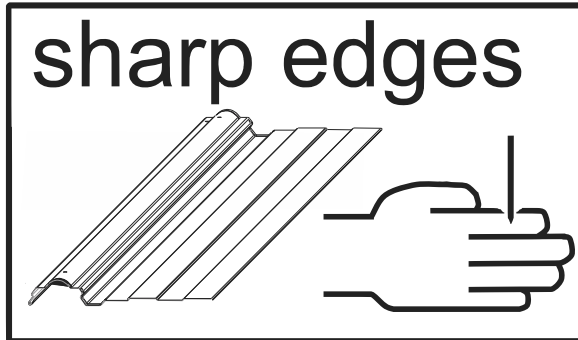

Care must be taken when handling various pieces of your building since many contain sharp edges. Please wear work gloves, eye protection and long sleeves when assembling or performing any maintenance on your building.



Practice caution with the tools being used in the assembly of this building. Be especially familiar with the operation of all power tools.



Keep children and pets away from the worksite during construction and until the building is completely assembled. This will help avoid distractions and any accidents which may occur.





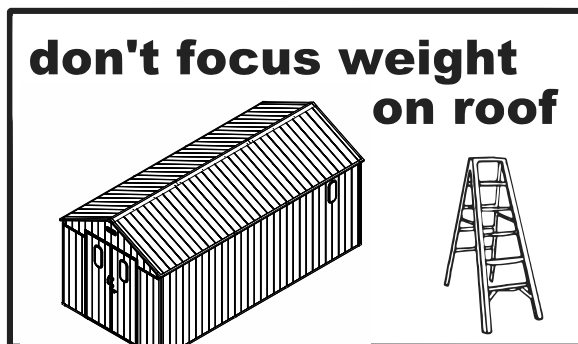





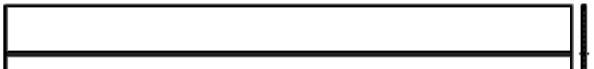





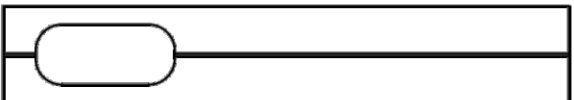







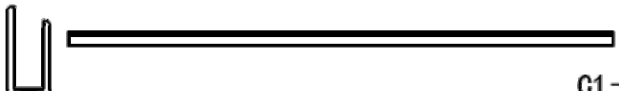





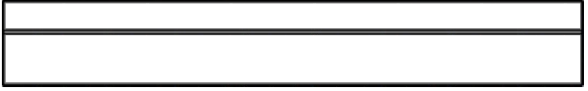

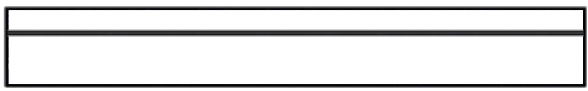
Do NOT attempt to assemble your building on a windy day. The large panels can catch the wind like a "sail", causing them to be whipped around making construction difficult and unsafe.









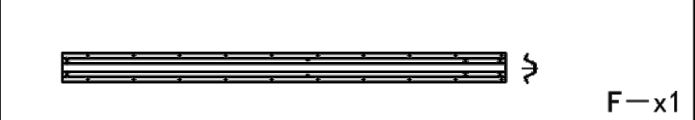
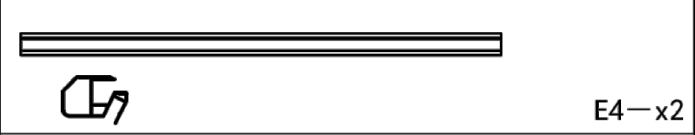
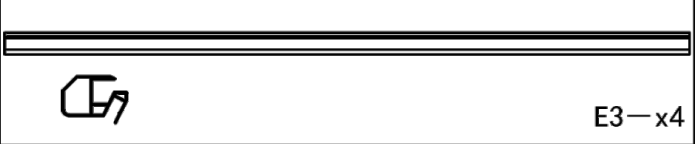
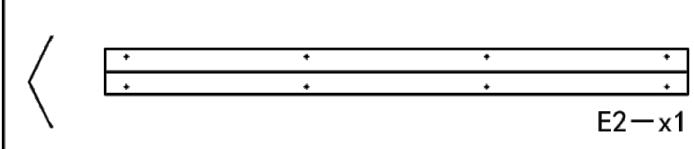
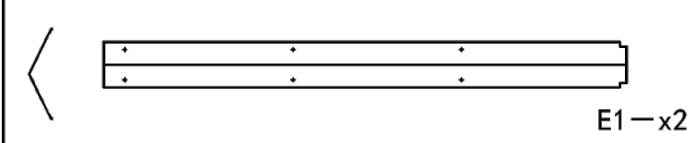
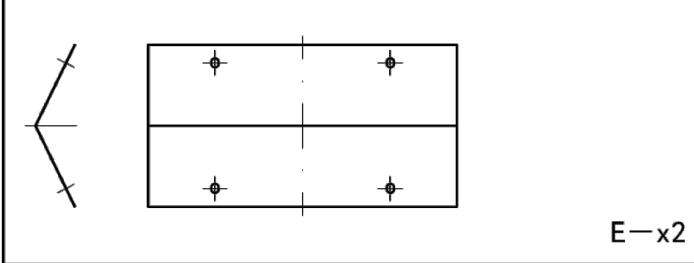
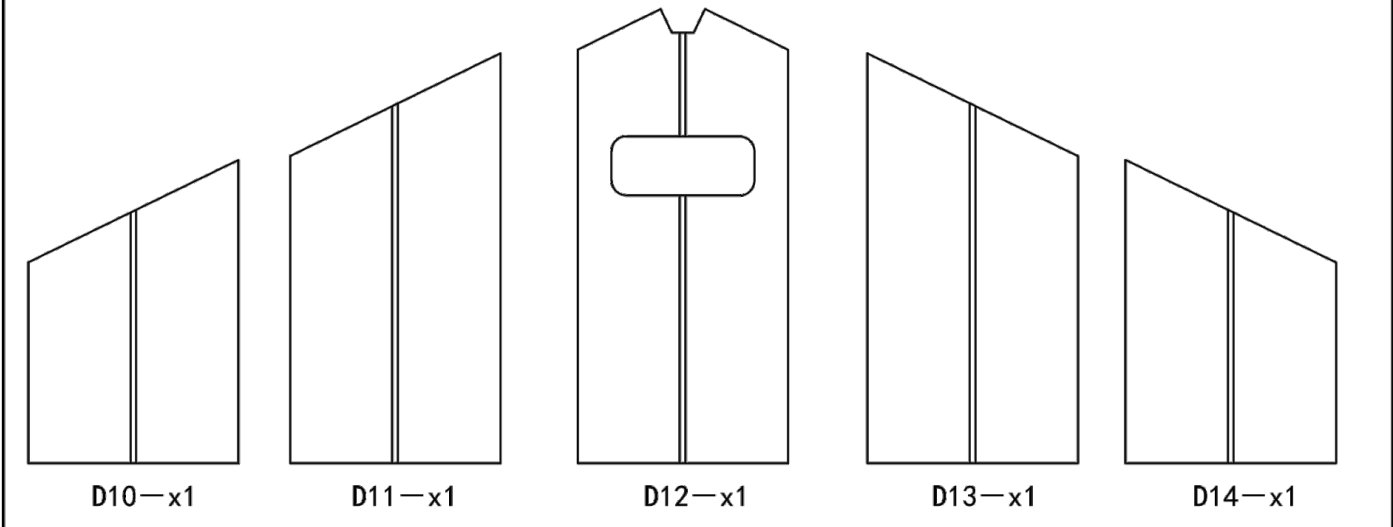
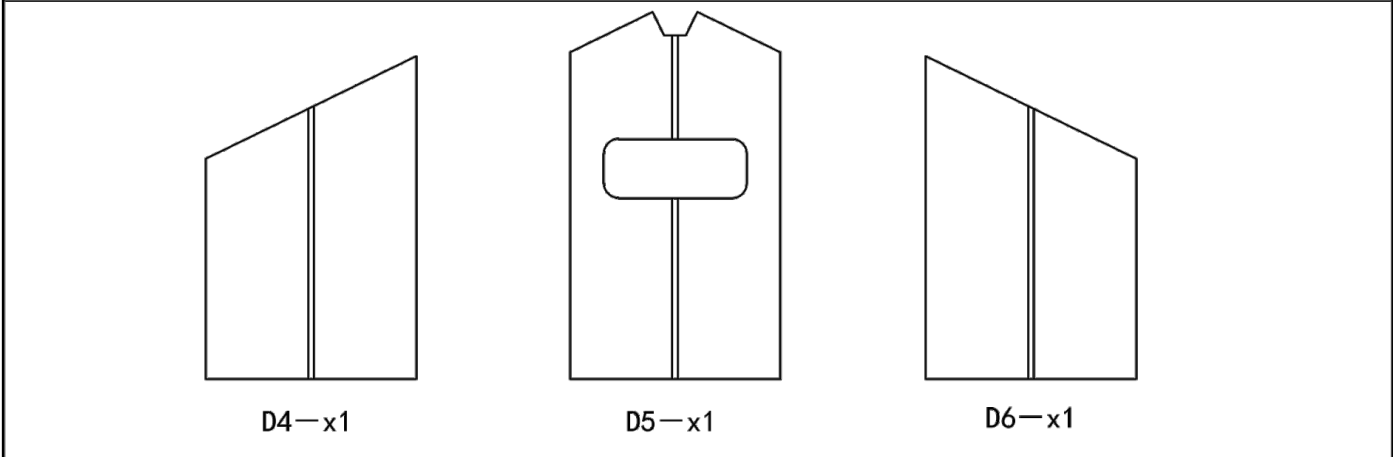
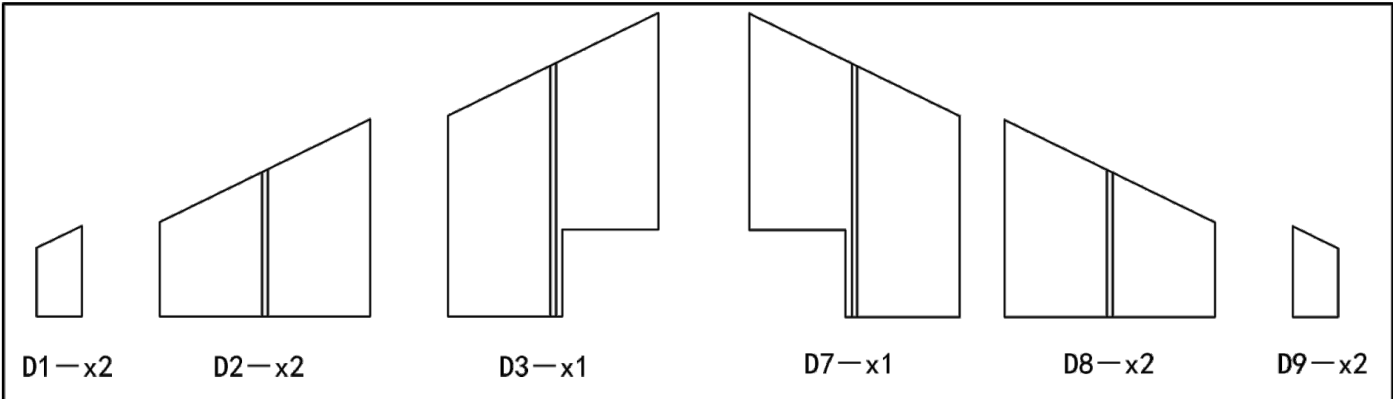



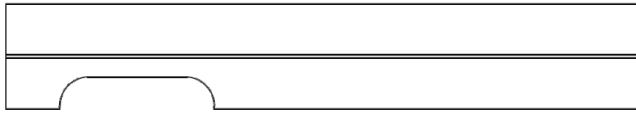



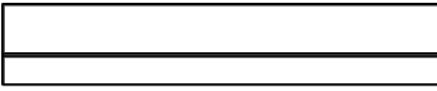





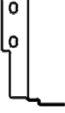
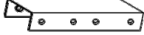
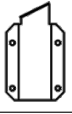



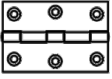
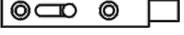



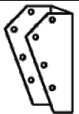

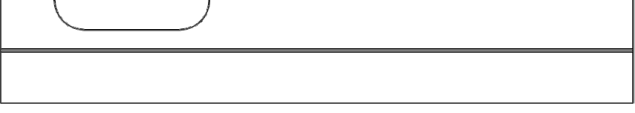
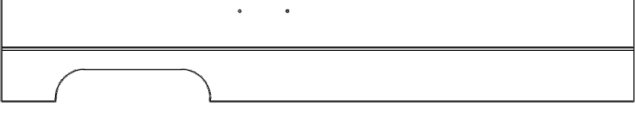

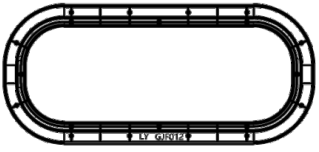

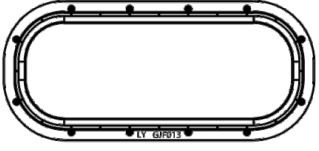

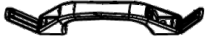

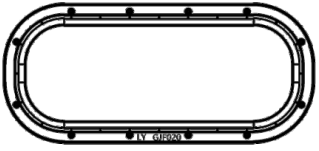

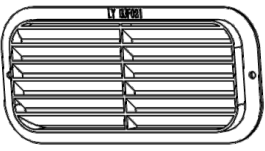

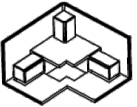

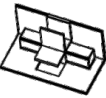
NEVER concentrate your weight on the roof of the building. When using a step ladder make sure that it is fully open and on even ground before climbing on it.

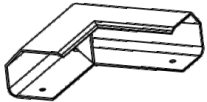
Do NOT attempt to assemble your building before double checking that you have all the parts indicated in the parts lists as well as all hardware. Any building left partially assembled may be seriously damaged by even light winds.

 A-x1	 B7-x4
 A1-x2	 B8-x26
 A2-x2	 B9-x30
 A3-x4	 B10-x2
 A4-x2	 Ba-x1
 Aa-x2	 Bb-x1
 Ab-x30	 C-x1
 Ac-x30	 C1-x1
 Ad-x3	 G2-x2
 B-x4	 G3-x2
 B1-x1	
 B2-x1	
 B3-x2	
 B4-x8	
 B5-x2	
 B6-x9	 Da-x4
	 Db-x4
	 Dc-x2
	 Dd-x2
	 De-x2
	 Df-x2

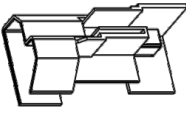
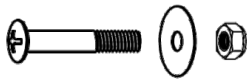

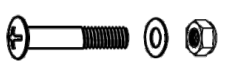
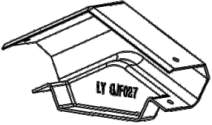
	F2-x2		M3-x1
	F3-x4		M4-x1
	F4-x4		M5-x2
	G-x28		M6-x2
	G1-x4		N-x2
	G2-x30		N1-x1
	H-x14		N2-x1
	H1-x14		H2-x4
	H3-x2		H4-x2
	H5-x2		H6-x2
	HY-x4		CX-x2
	J-x10		Q-x1
	J1-x5		Q3-x2
	K-x10		Q4-x1
	M1-x1		
	M2-x1		

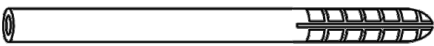
	GJF012-x4		R-x4
	GJF013-x2		M5x8 1# - x82
	GJF016-x2		M5x38 3# - x86
	GJF020-x2		4x9 5# - x464
	GJF021-x2		4x14 6# - x48
	GJF022-x4		4x14 7# - x108
	GJF023-x5		4x10 8# - x570
	GJF024-x4		3x8 9# - x32
	GJF025-x4		3x19 10# - x48
	GJF026A-x1		M5x28 12# - x4
	GJF026B-x1		M5x25 13# - x7
	GJF027-x2		Phillips Screwdriver
			14# - x14

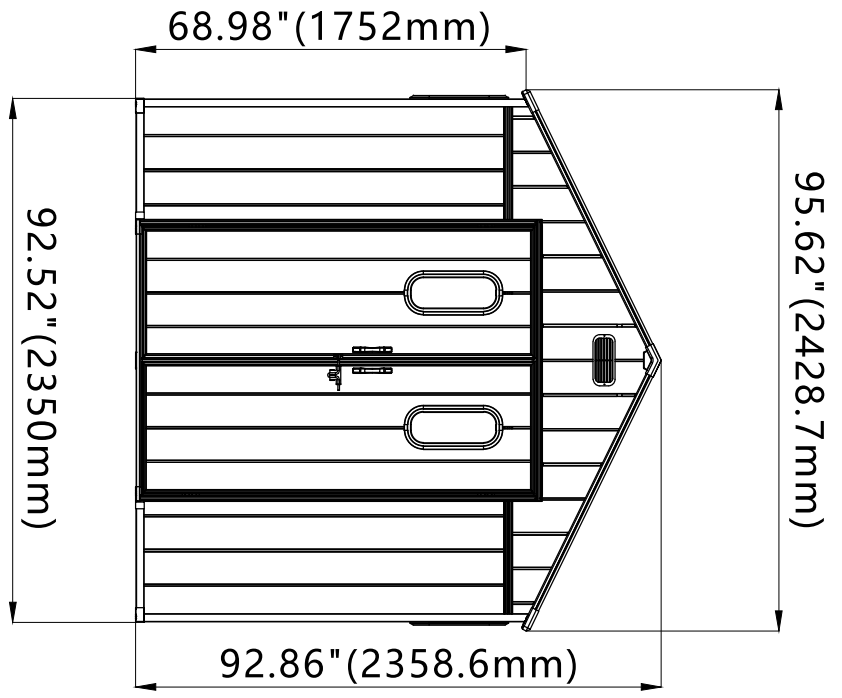
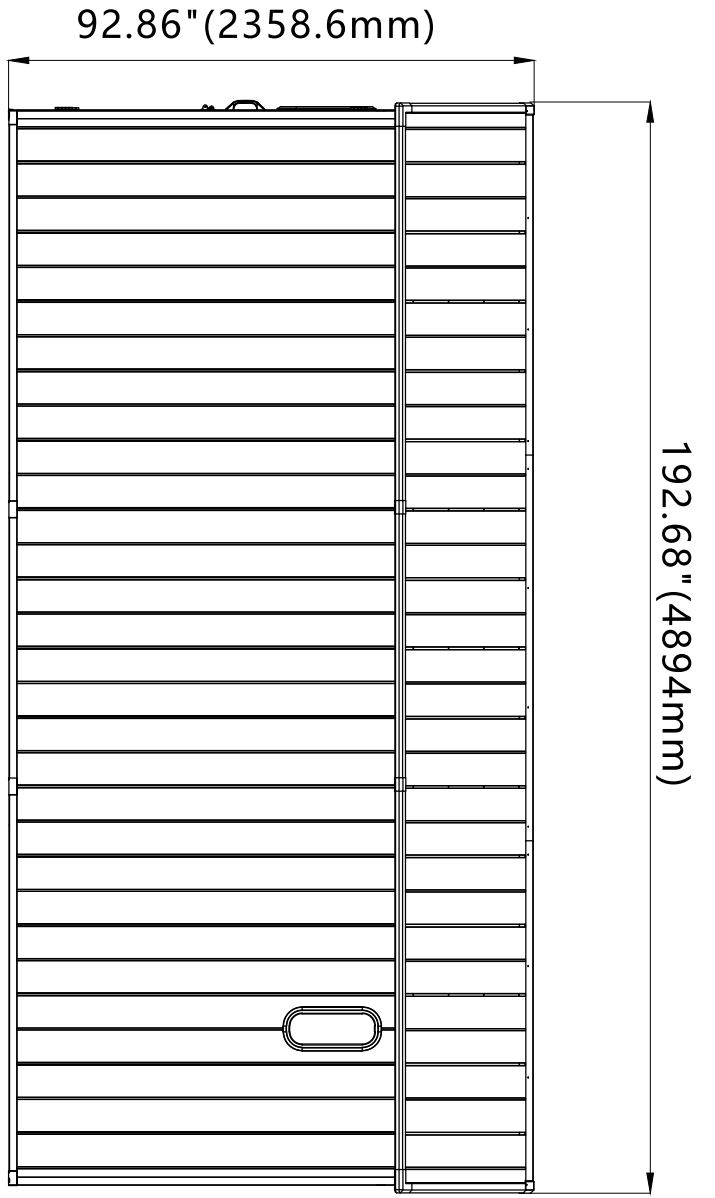
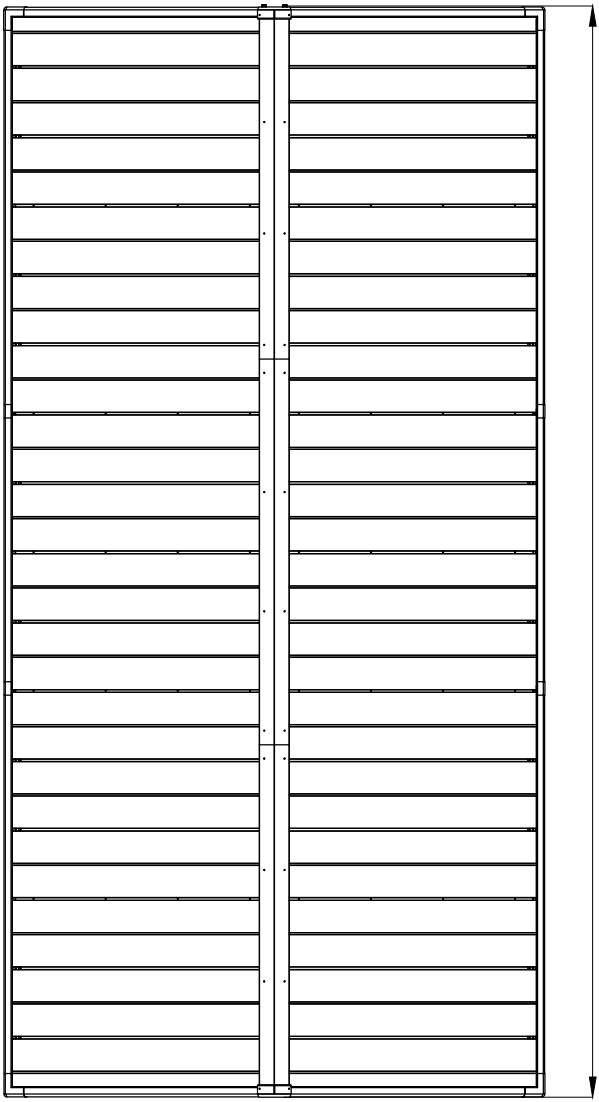

THE BASE FOR YOUR BUILDING

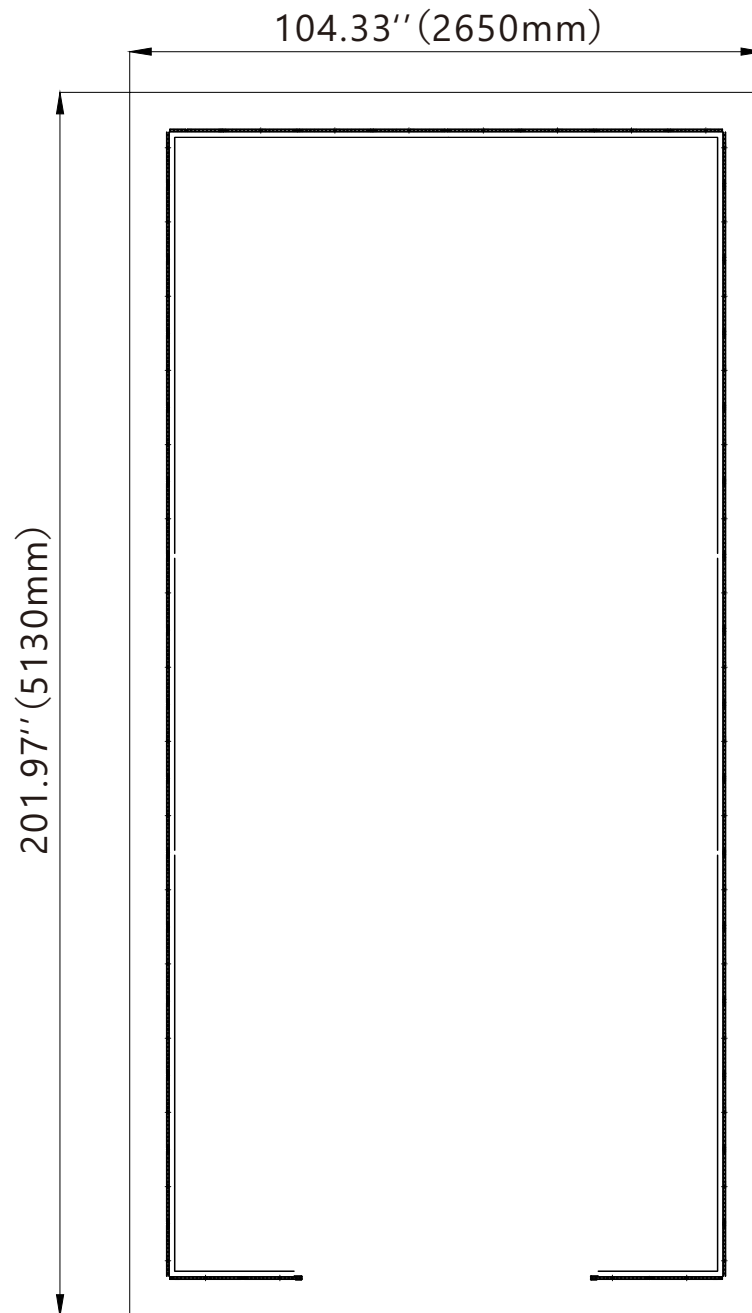

1. Leveling the ground.

2. Set up the base: It is recommended to build a wooden base or concrete base.

Foundation Requirements:

(1) The area of the foundation should not be less than the size range in the figure.

(2) The thickness of the concrete should not be less than 7cm.

(3) The base surface must be measured by the spirit level to be in a flat state.

(4) The base surface must be higher than the ground to prevent water accumulation.

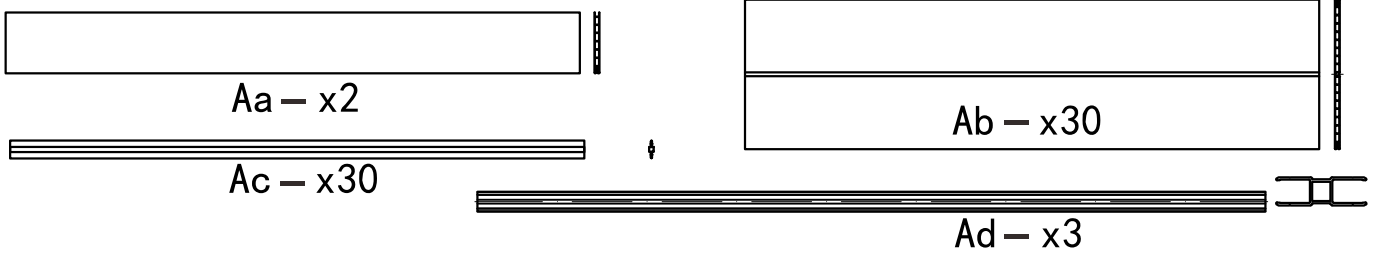

Install the Floor

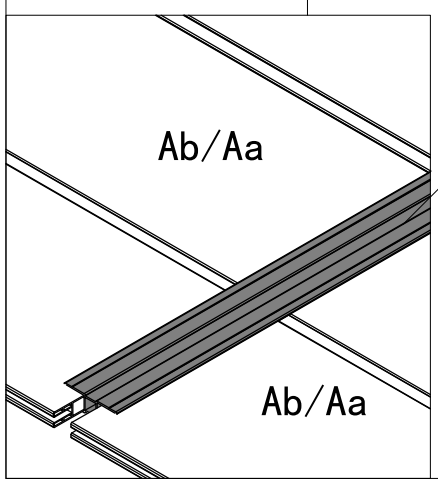
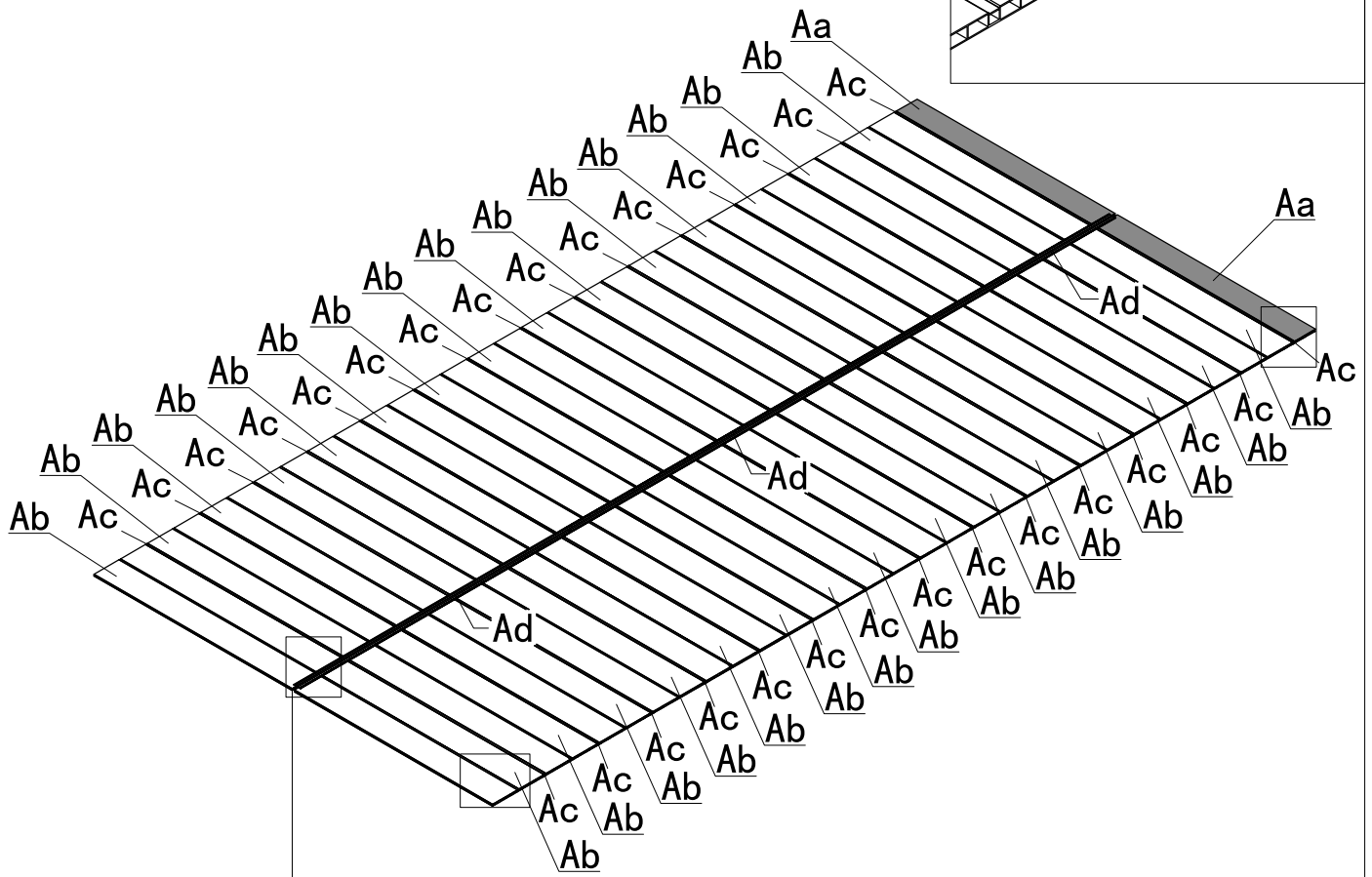
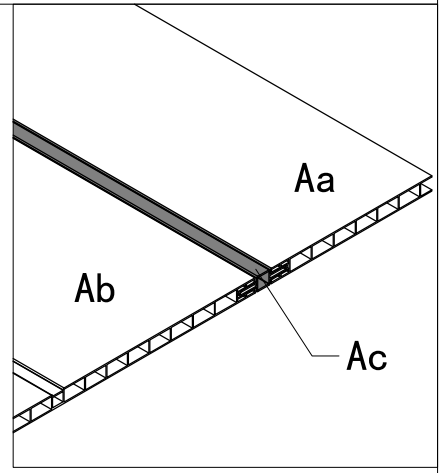

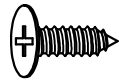

4x9

5# - x120



4x10

8# - x30

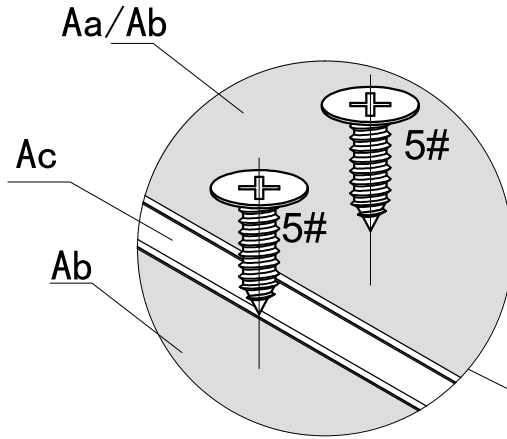

Use Screw #5 to secure each floor panel with connecting rod #Ac as shown (It is recommended to pre-mark straight lines on the floor to ensure that the screws are installed neatly and attractively).

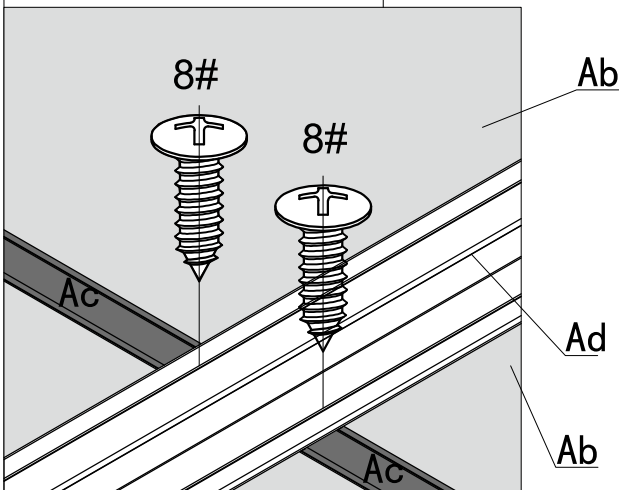
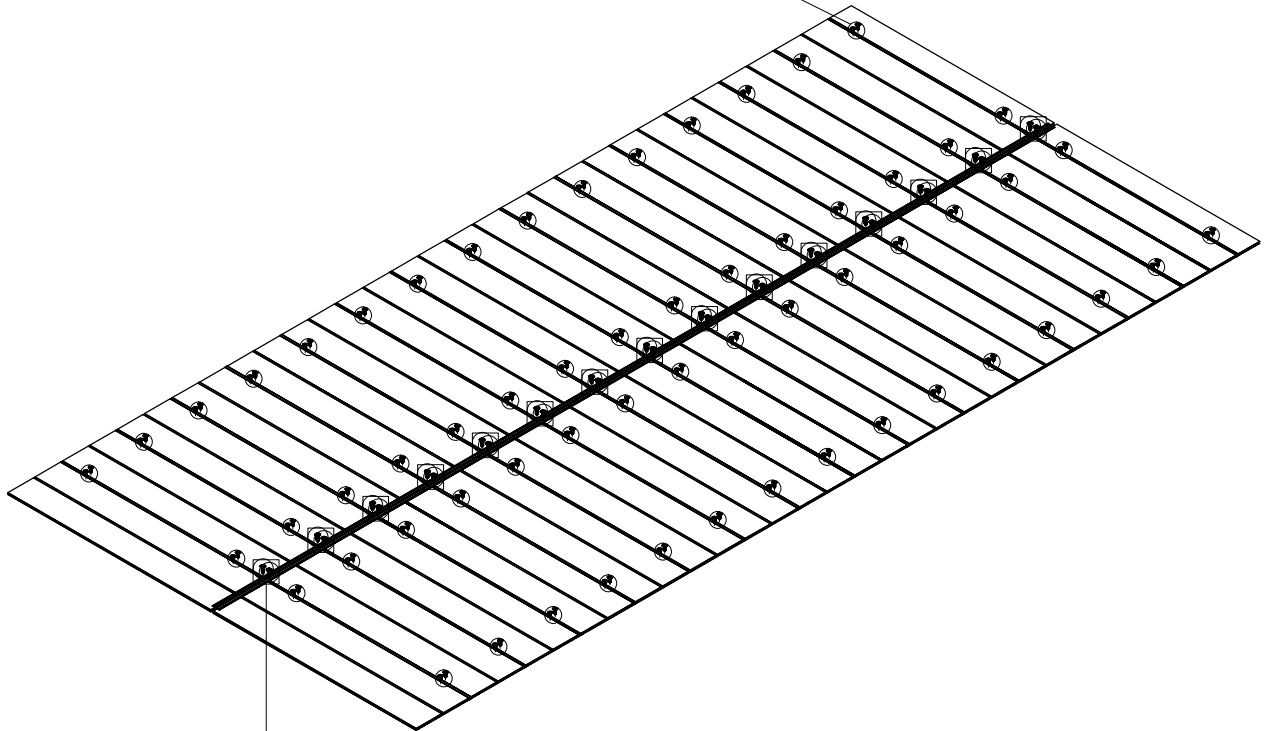

Use Screw #8 to secure base frame #Ad with each floor as shown (The screws can be installed on the ridges of the #Ad as shown).

Before fastening the screws, make sure that the spliced floor is rectangular and its edges are aligned.

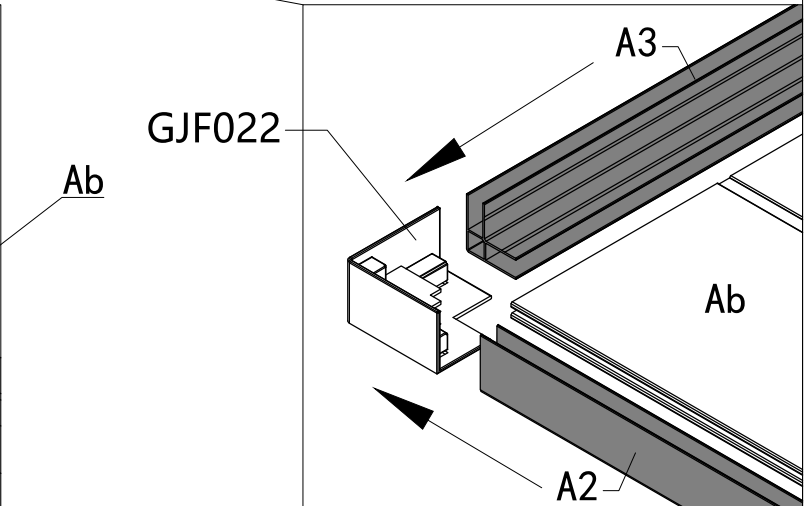
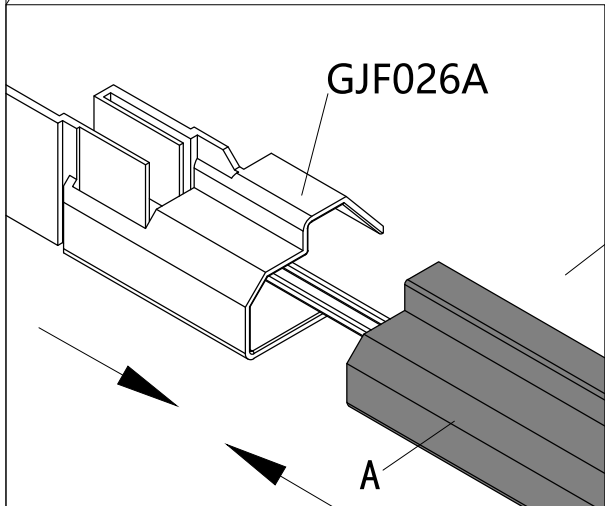
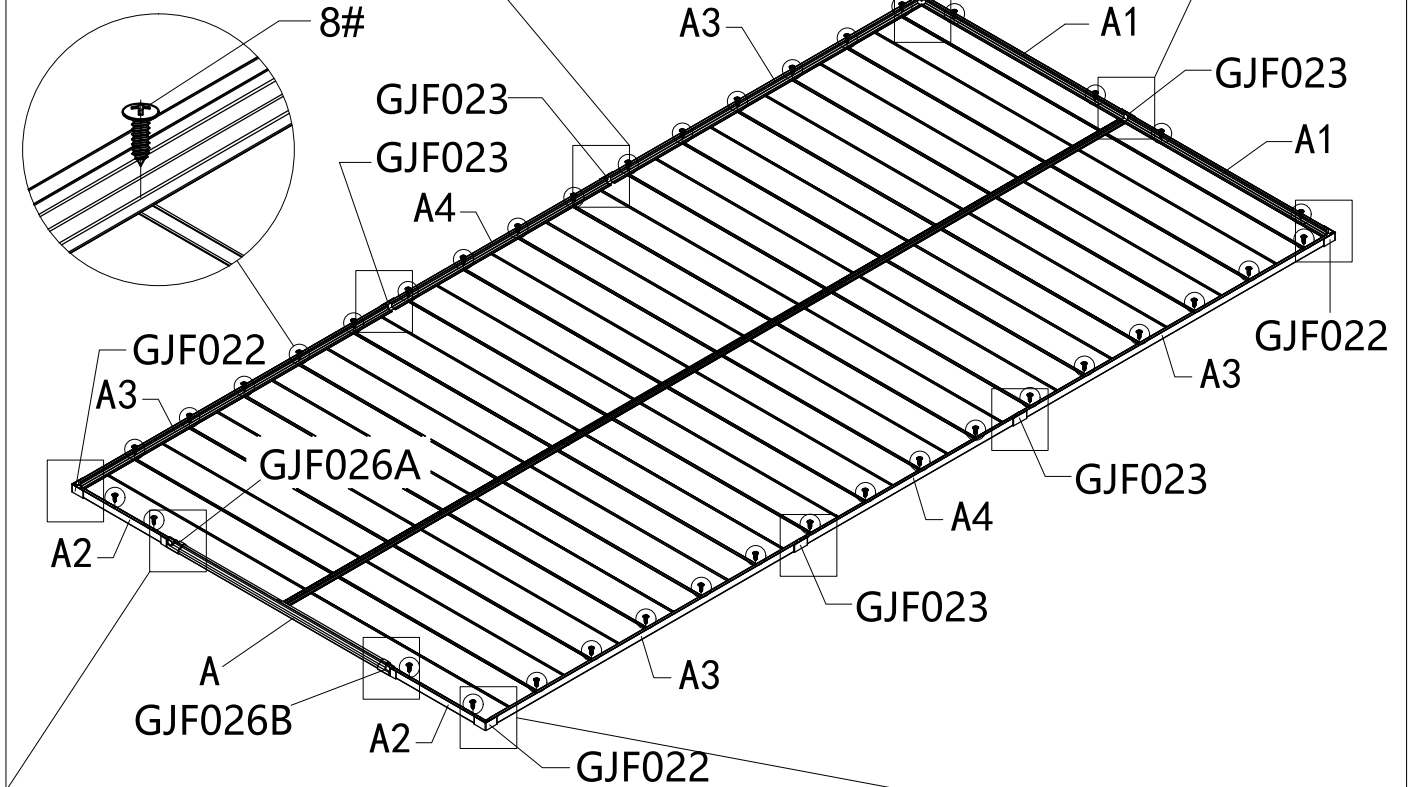
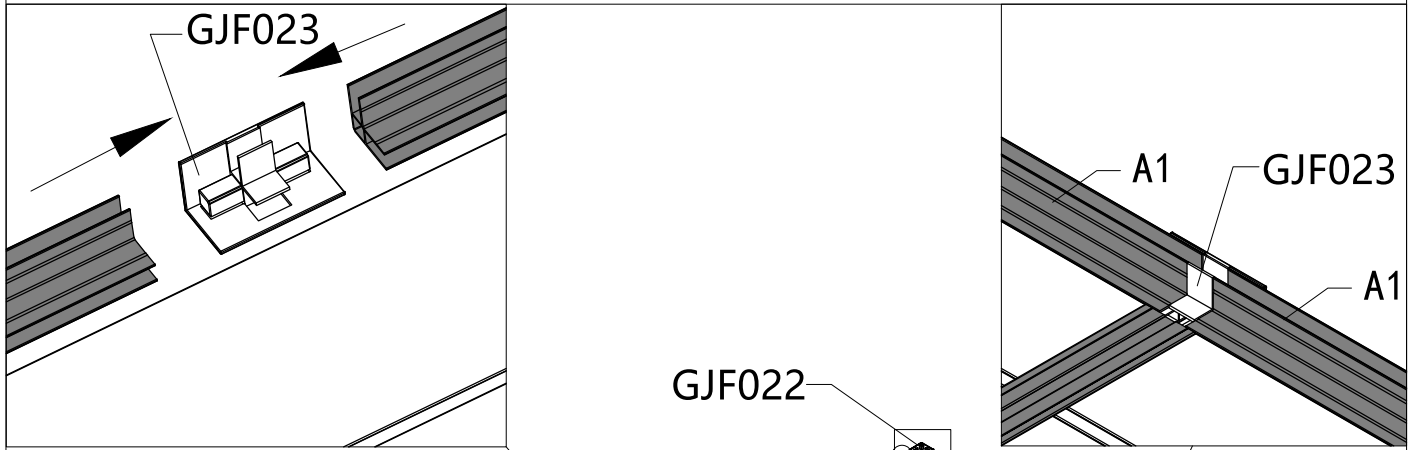
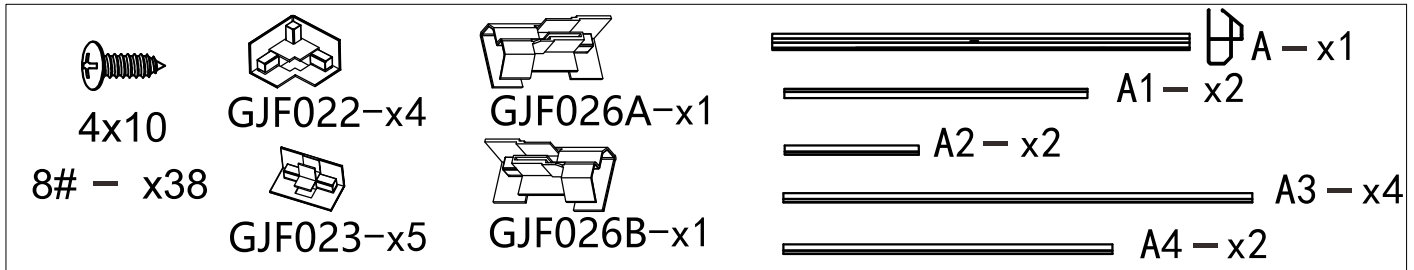

Base Frame Assembly:

1. Insert the floor to the groove of the base frame kits.
2. After all the kits are assembled, use screw #8 to secure the base frame with floor.

Use 30 screws #8 to secure the base frame #A3,A4 to the connecting rod #Ac as shown.

Use 8 screws #8 to secure the base frame #A,A1,A2 and connecting kit to the floor as shown.



4x10

8# - x8

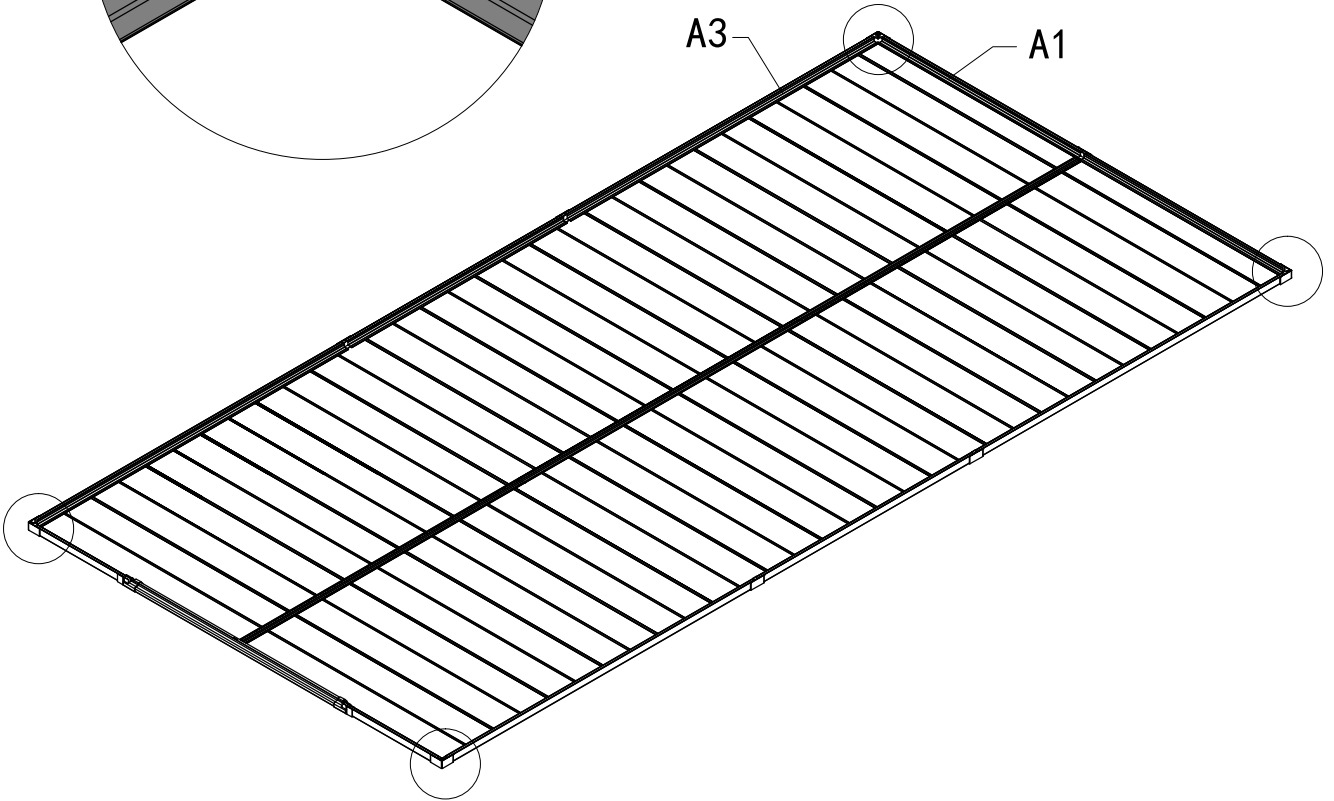
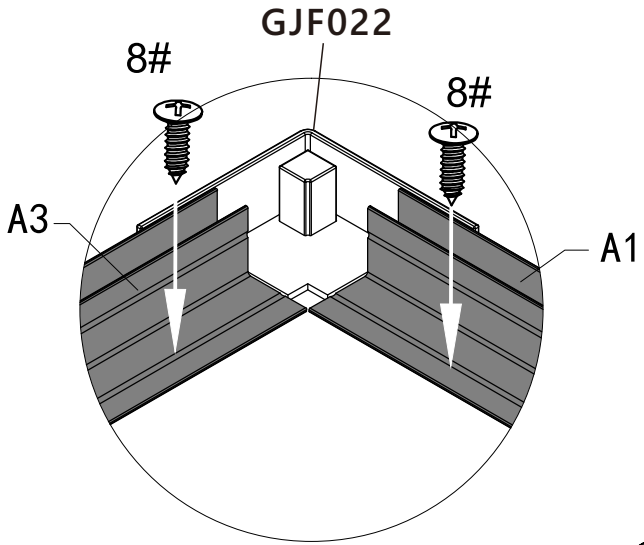

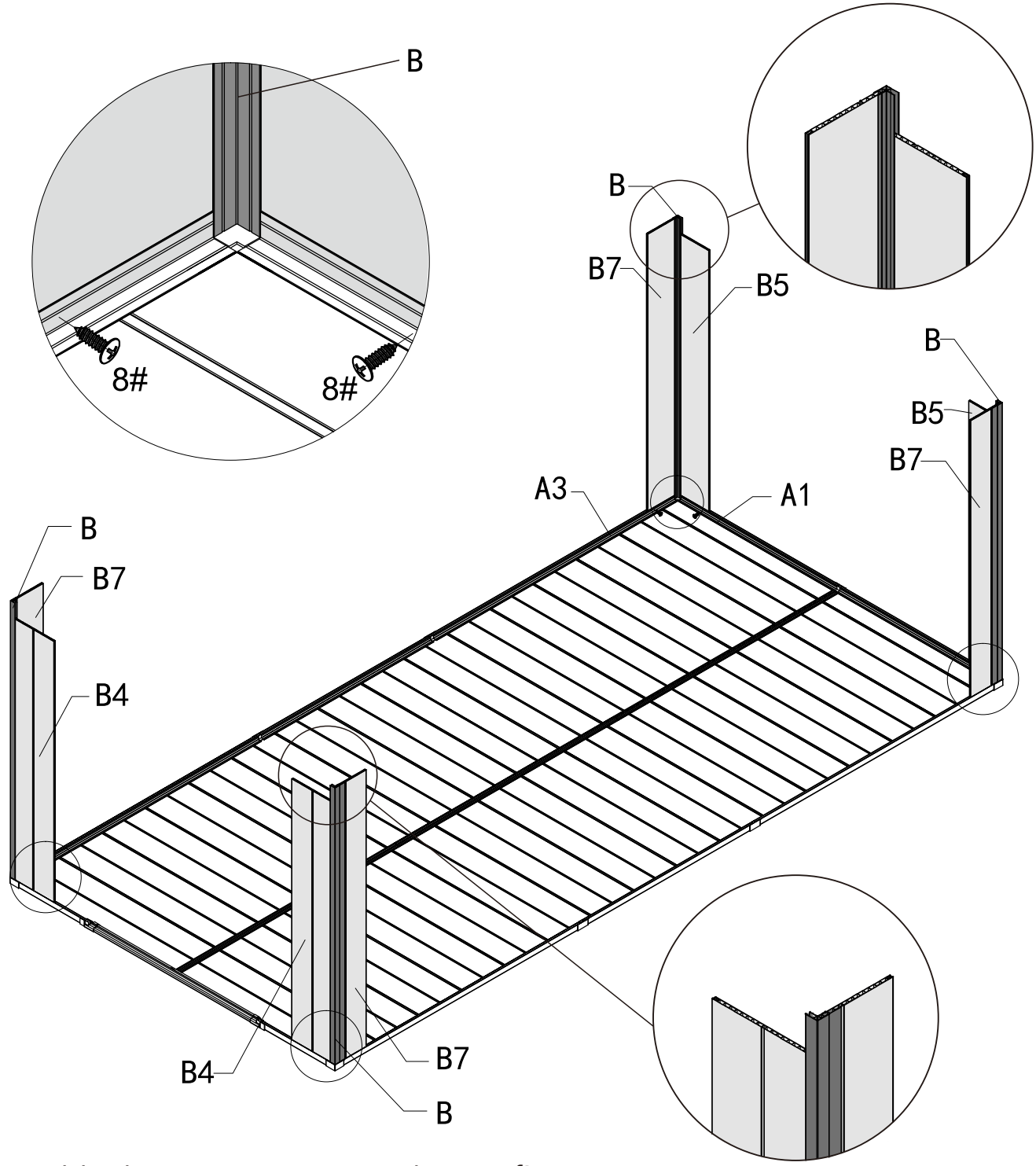
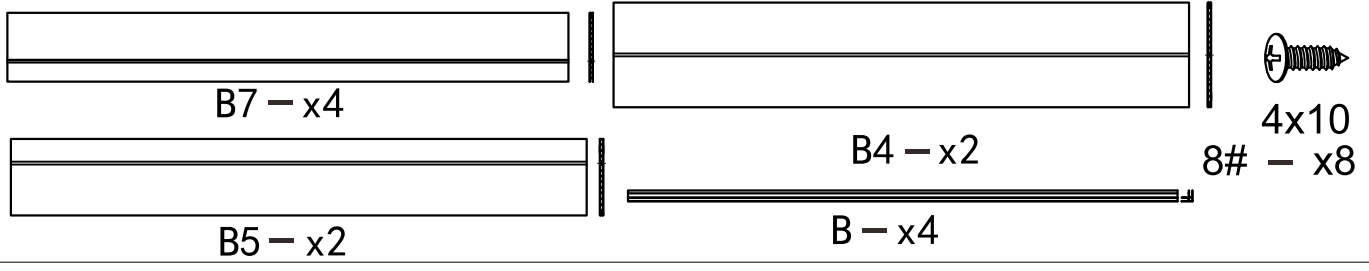

Assemble the corner support tubes #B first,
 Insert the wall panels to the groove of base frame and corner support tubes
 #B, then secure with 2 screws #8 at each bottom.

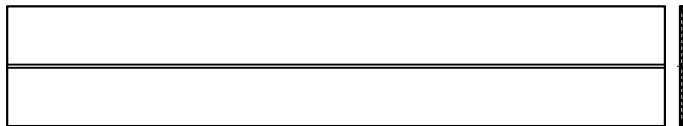

B4 - x6

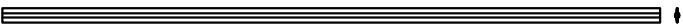

B6 - x7



4x10
8# - x12

Note: Each panel should tightly lock to each other without any gap. Otherwise, there will not be enough space for last panel.

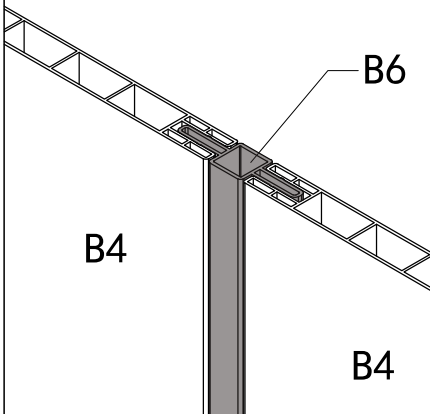

B4

B6

B4

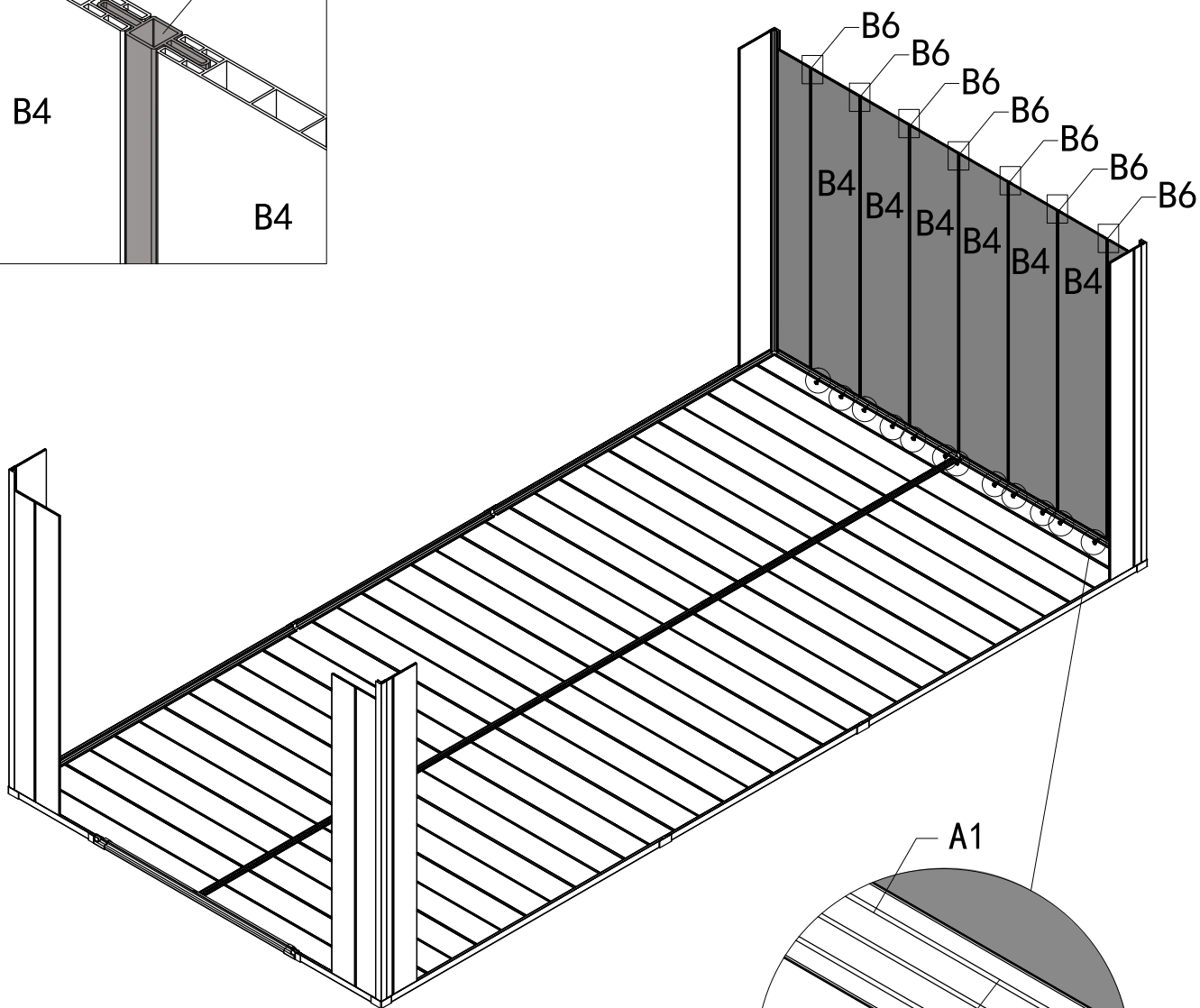

B6

B6

B6

B6

B6

B6

B6

B4

B4

B4

B4

B4

B4

B4

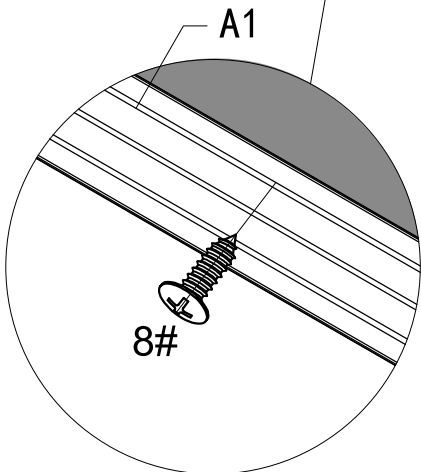

A1

8#

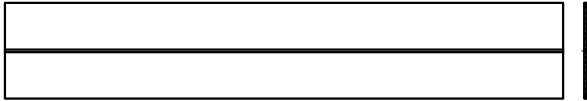

B8 - x26

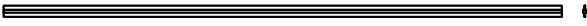

B9 - x30



4x10
8# - x56

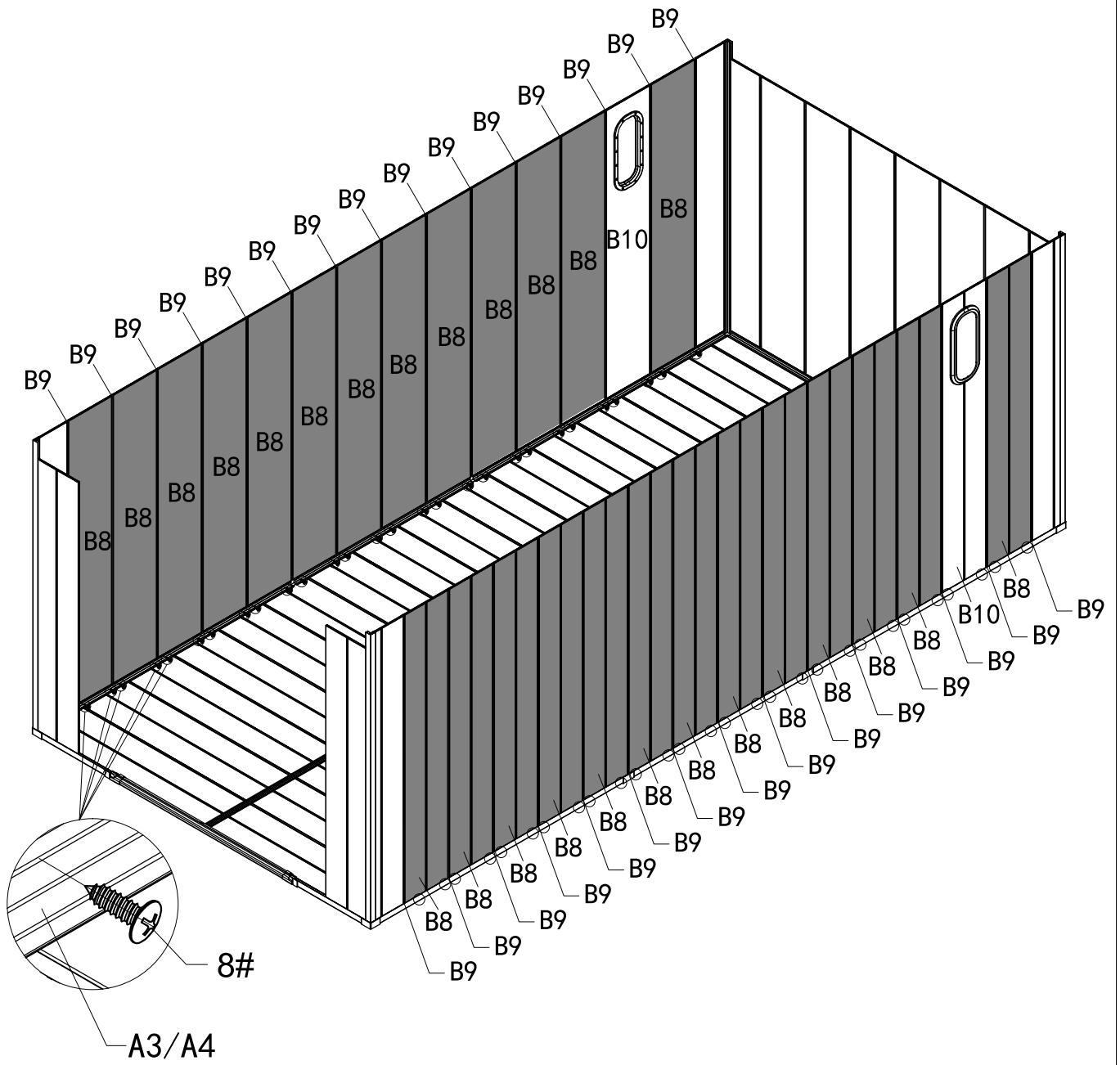

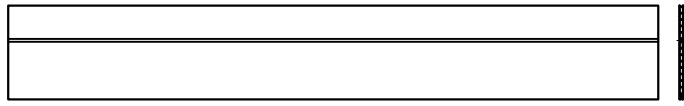

B3 - x2



4x10
8# - x4

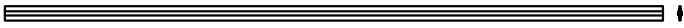

B6 - x2

Assemble wall panel #B3 and secure to the base frame with 1 screw #1 on each side. Use 1 screw #1 to secure the connecting kit #GJF026A/GJF026B with base frame #A.

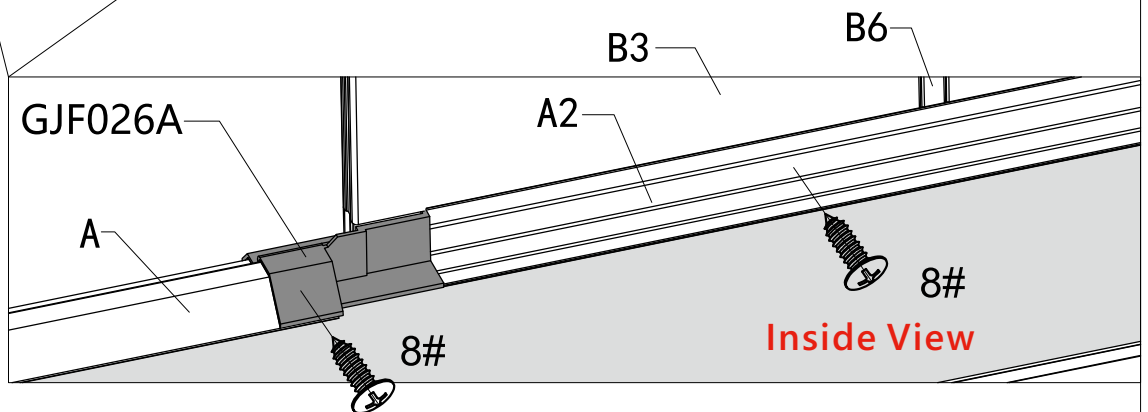
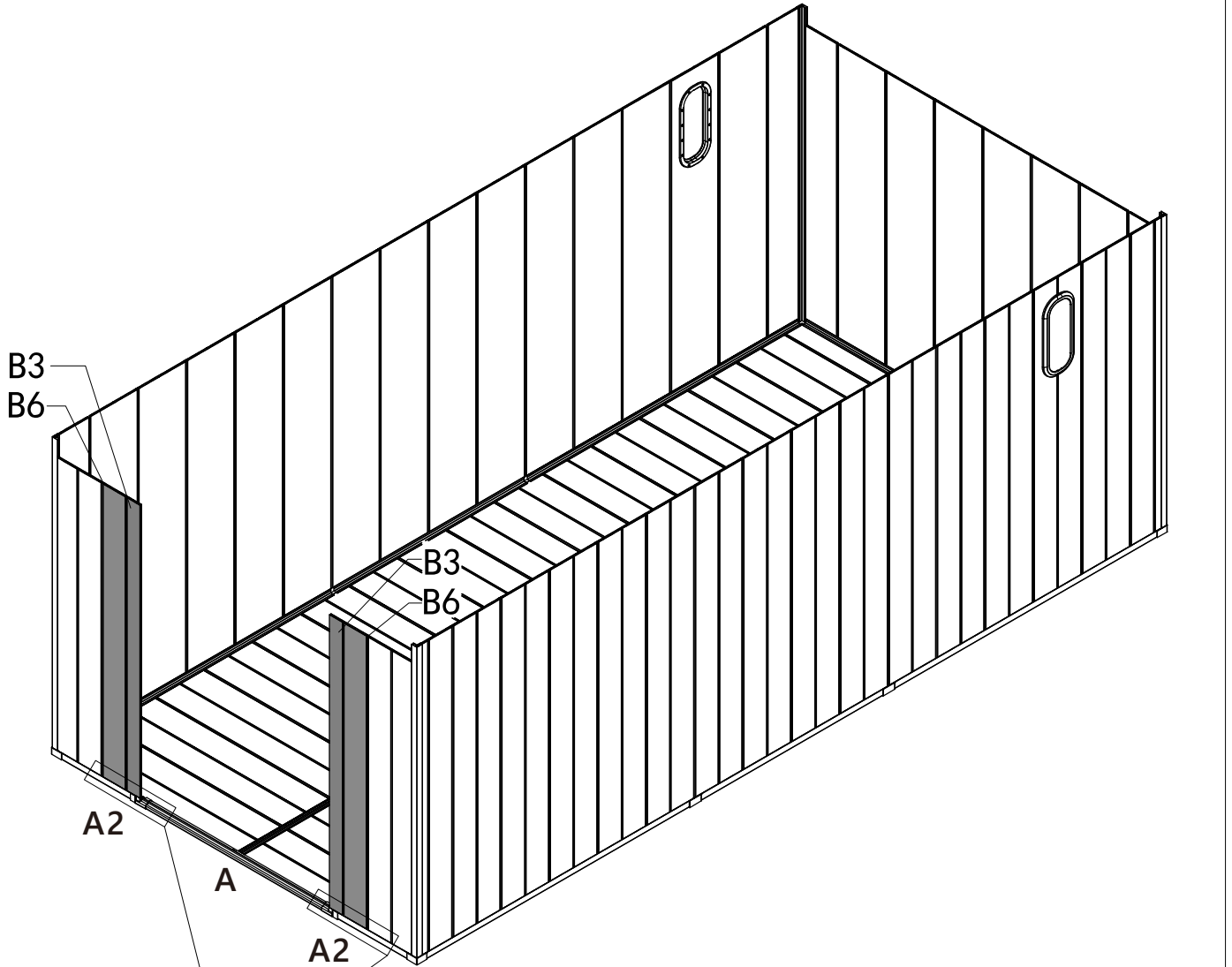

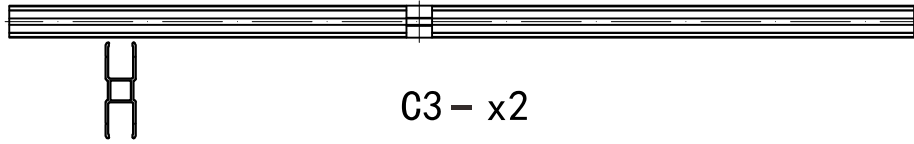

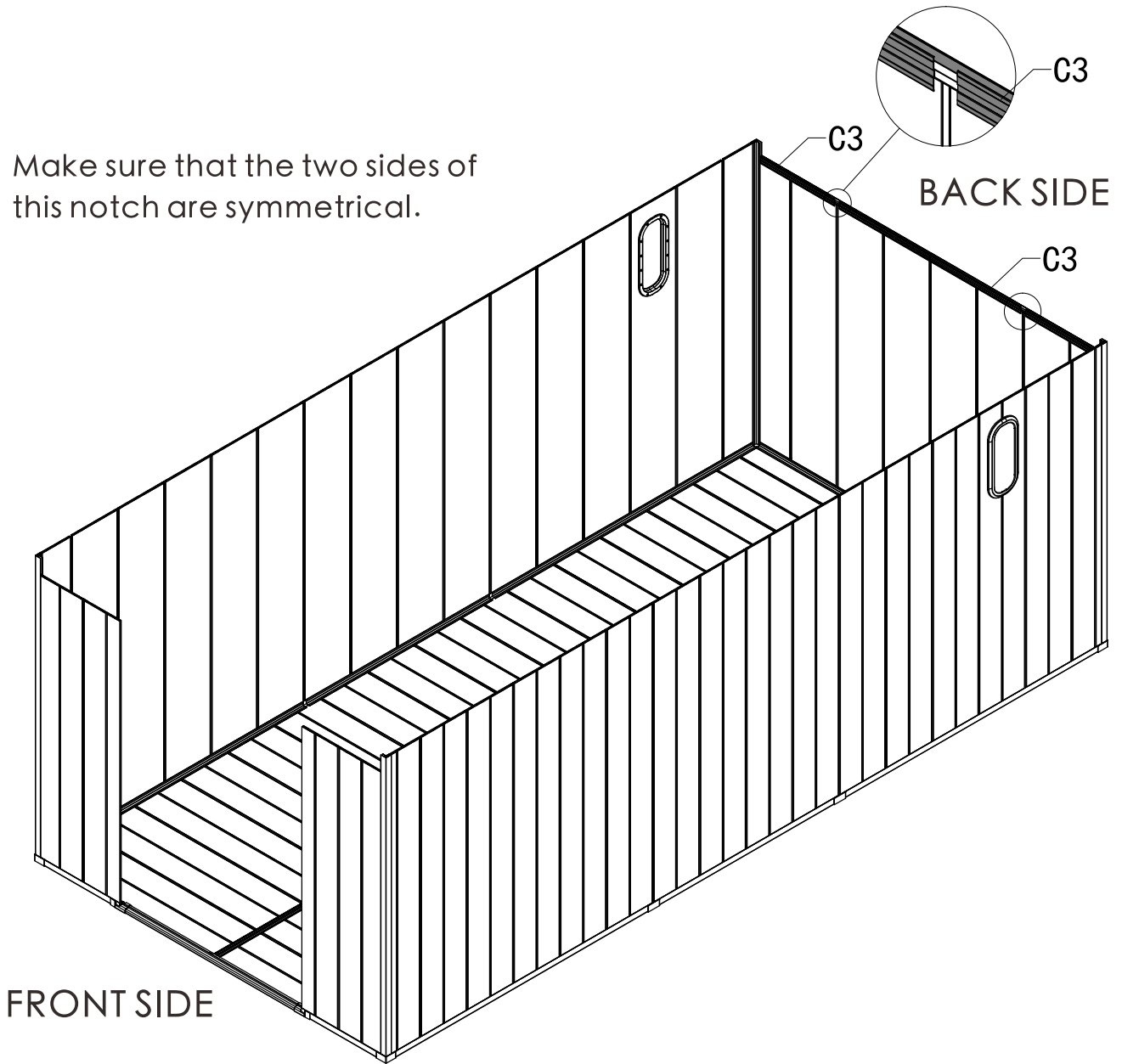

Make sure that the two sides of this notch are symmetrical.

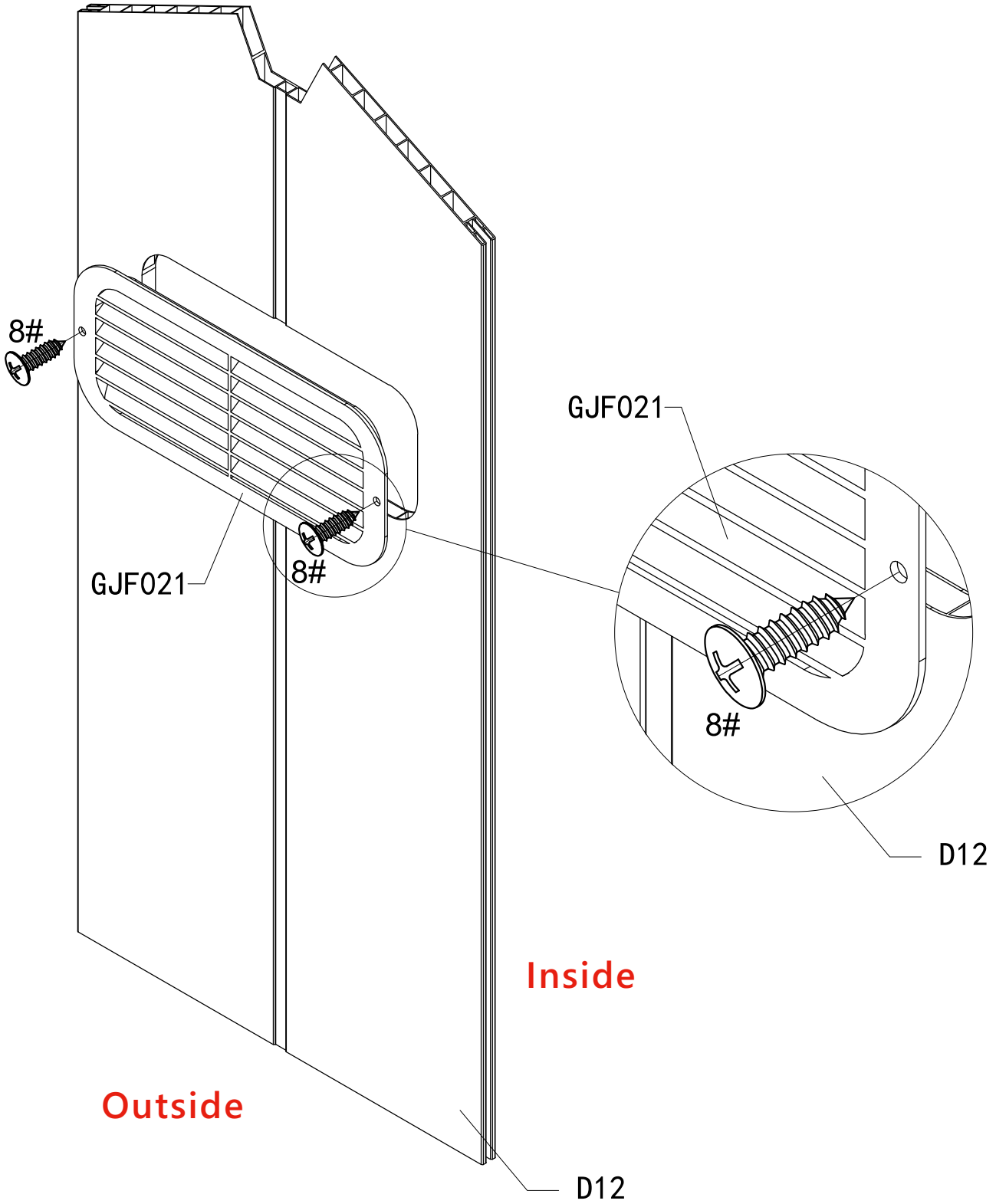
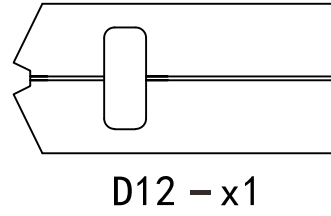
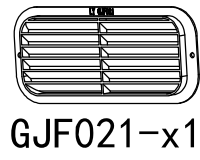

4x10
8# - x2



4x10
8# - x28

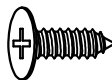

4x9
5# - x28

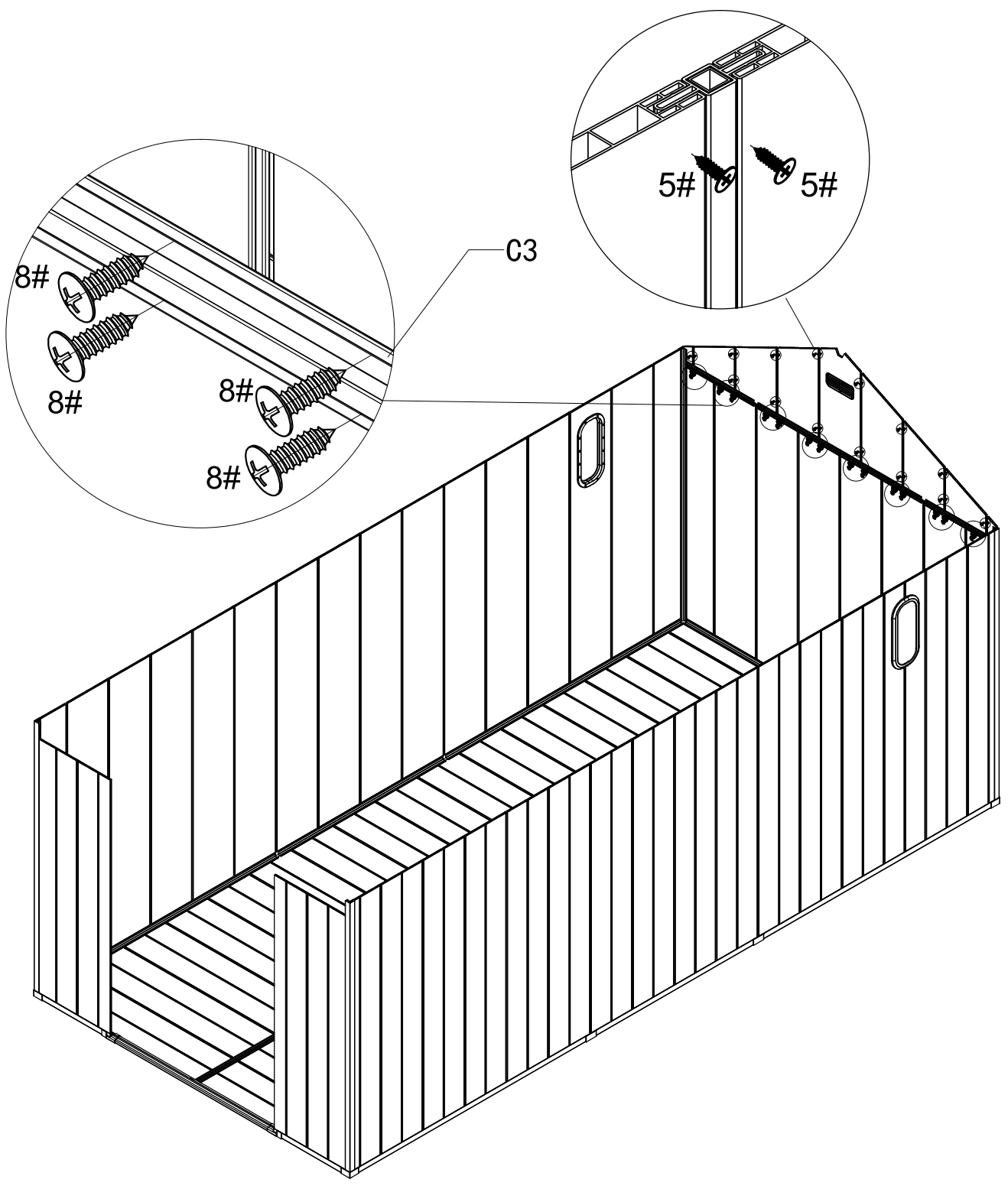
Use 28 screws 5# to secure the panels with connecting rods.
Use 28 screws #8 to secure top frame#C3 with the UPPER and LOWER panels.





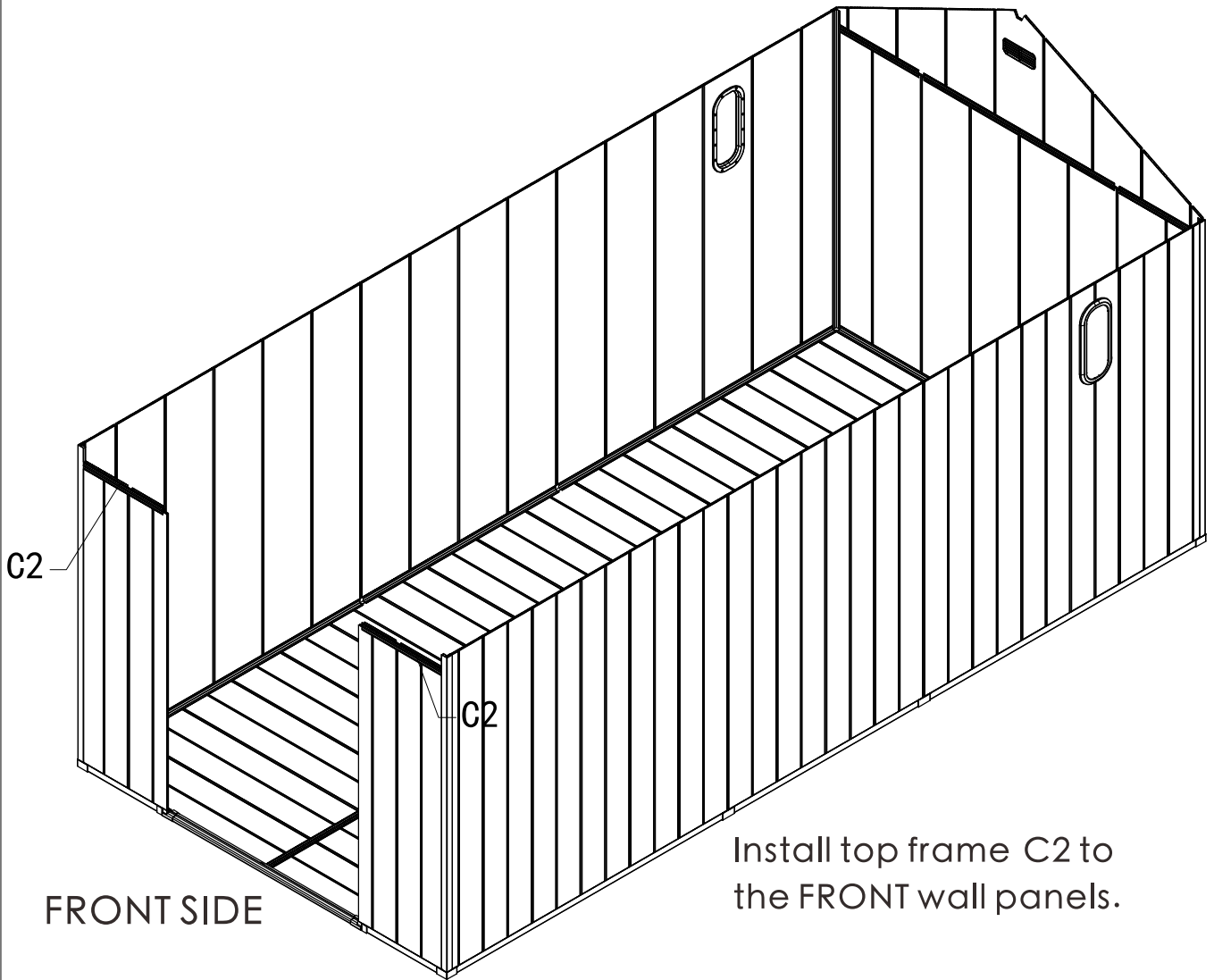

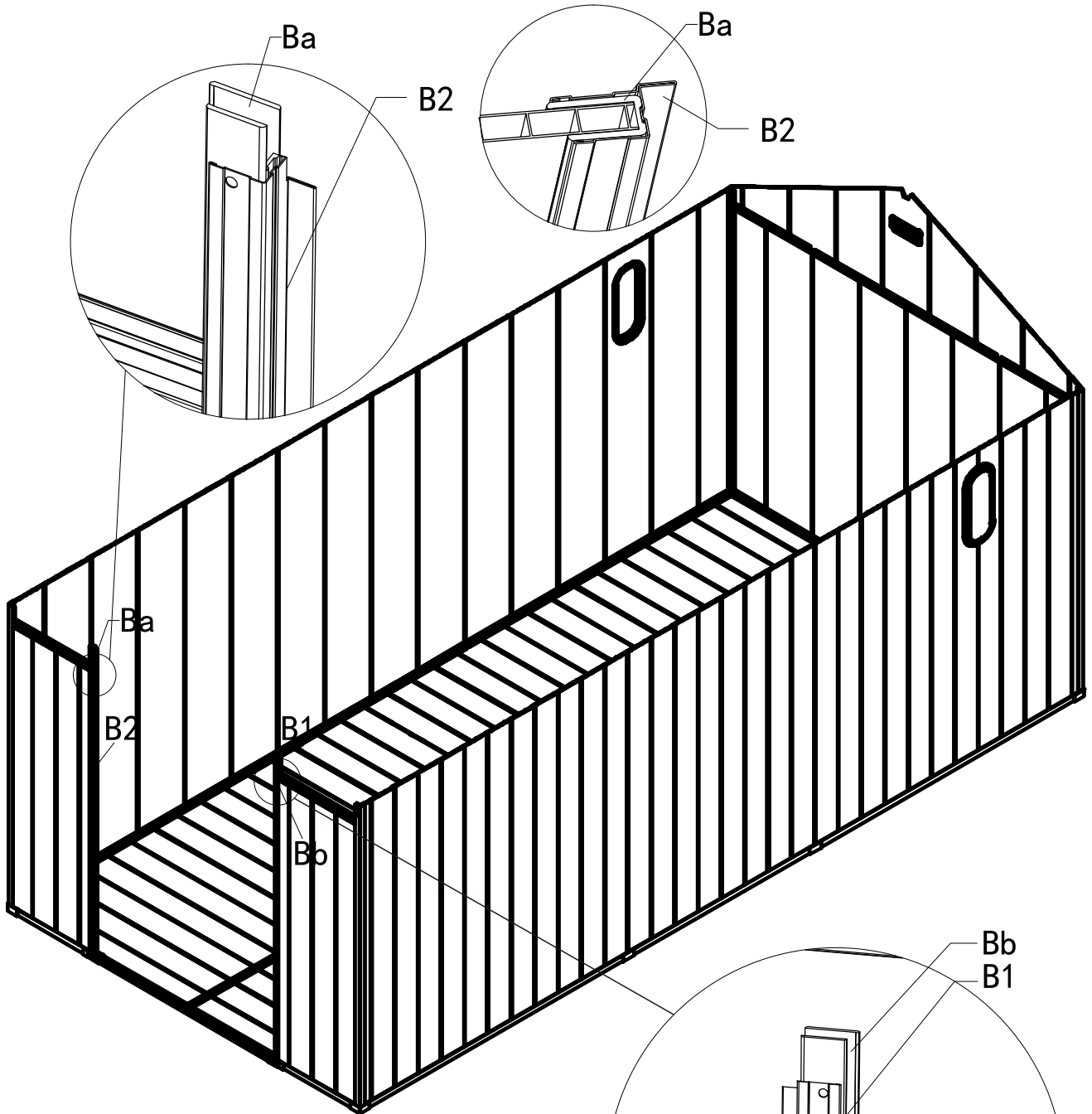
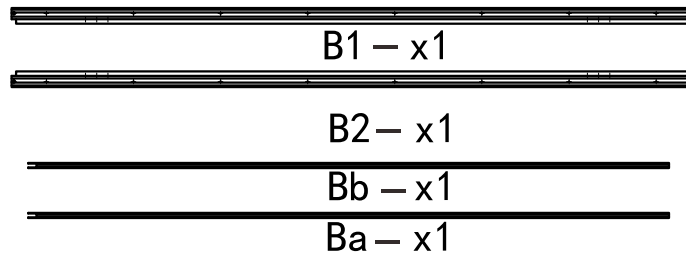

C2 - x2



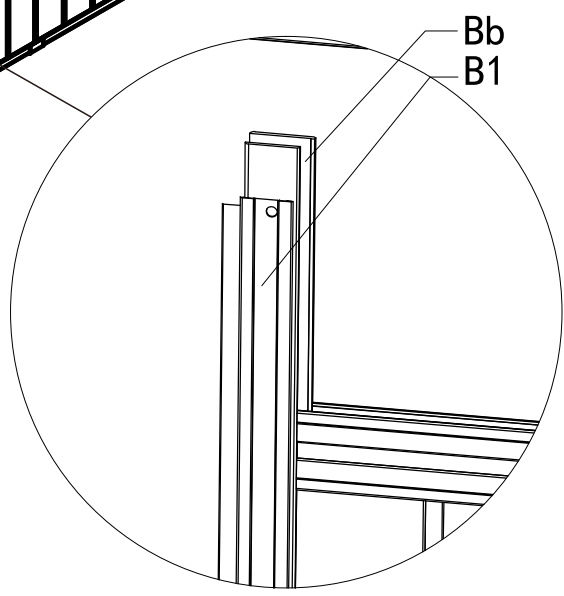

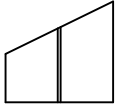
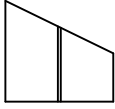

Fit the plastic door frame liner #Ba and the metal door frame #B2 into the wall panel as shown. Repeat the above steps to install #Bb and #B1 on the other side.



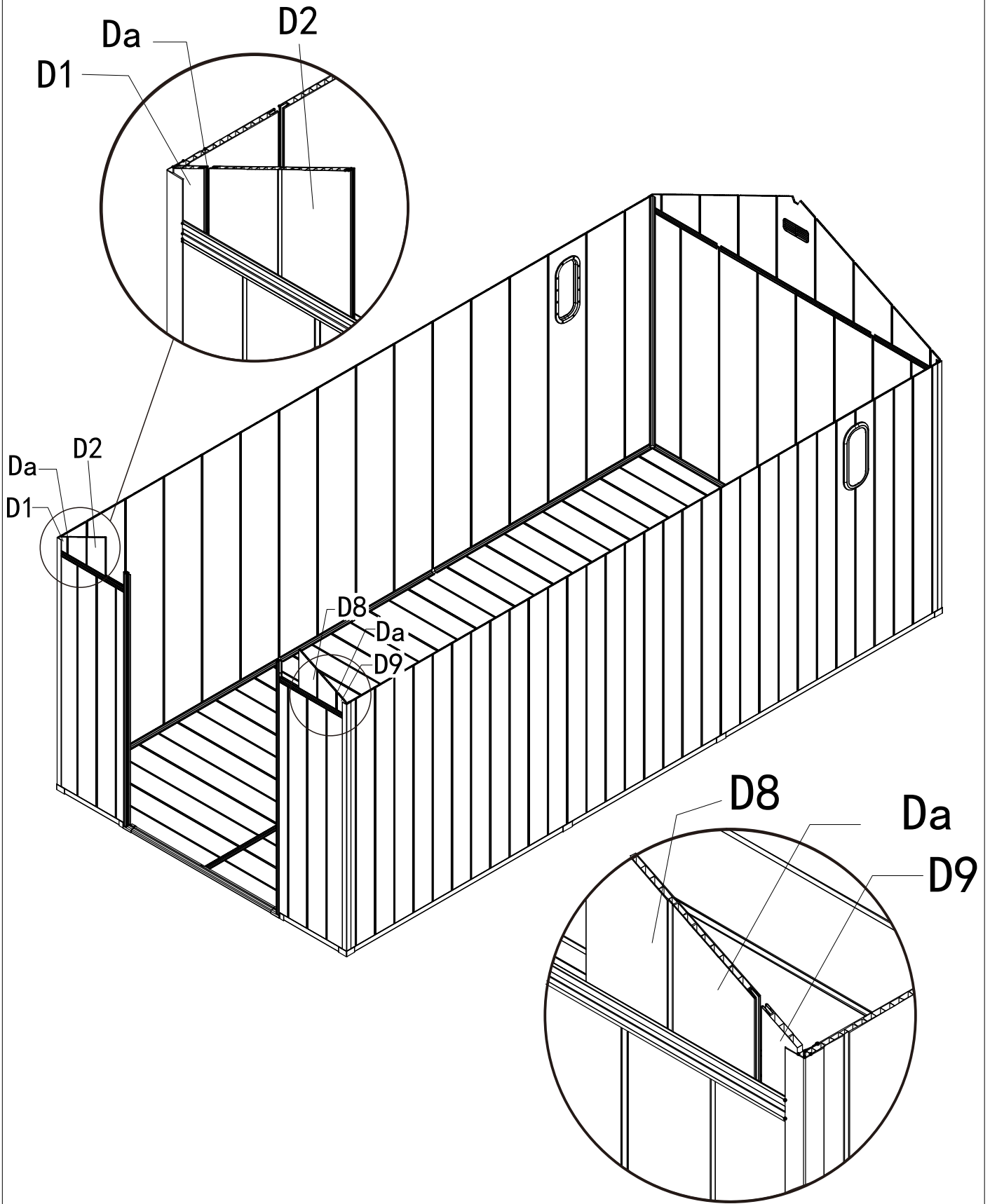

 D1 - x1
 
 D2 - x1
 
 D8 - x1
 
 Da - x2
 
 D9 - x1





4x10
8# - x2



GJF021-x1

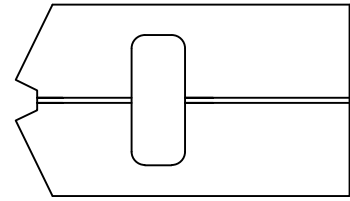

D5 - x1

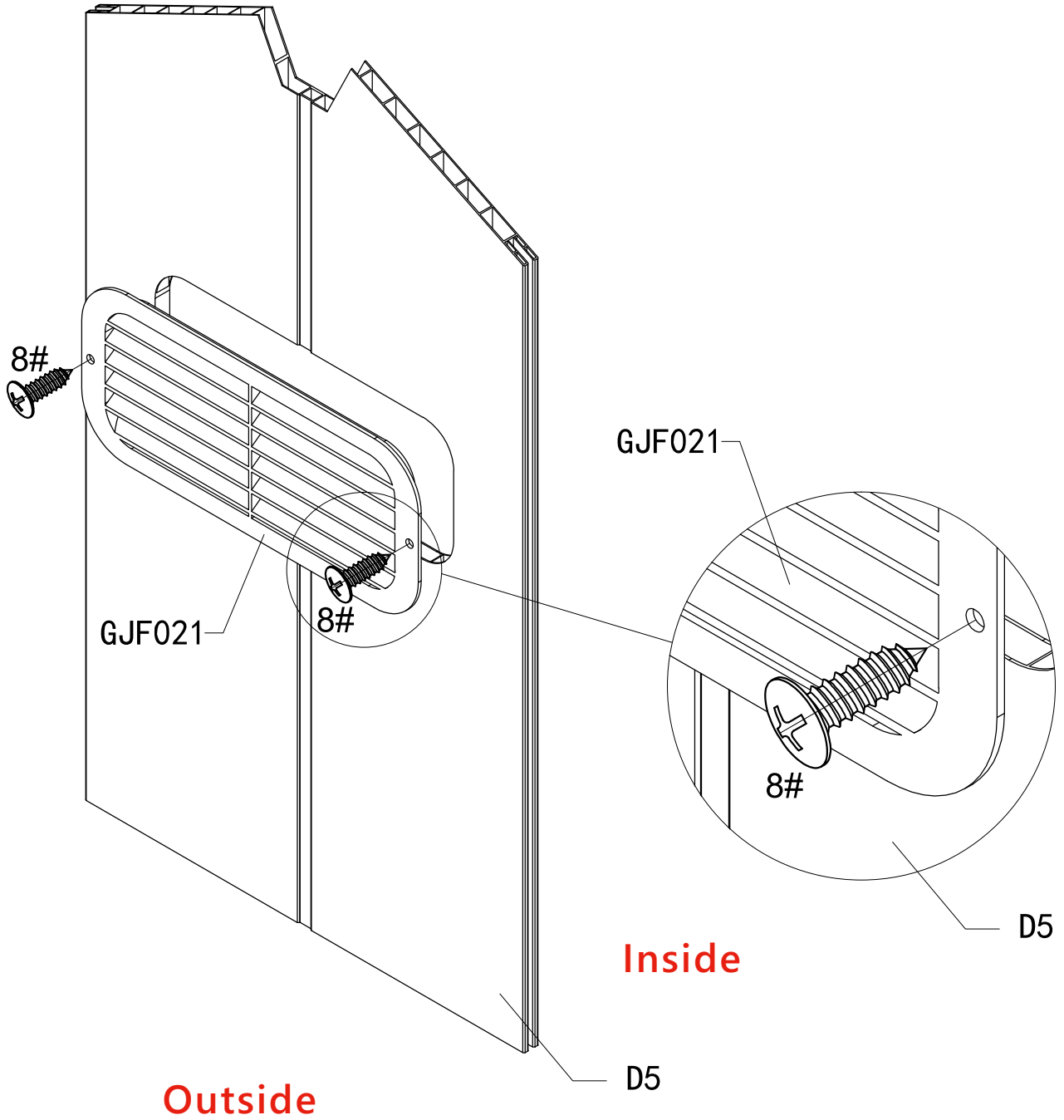

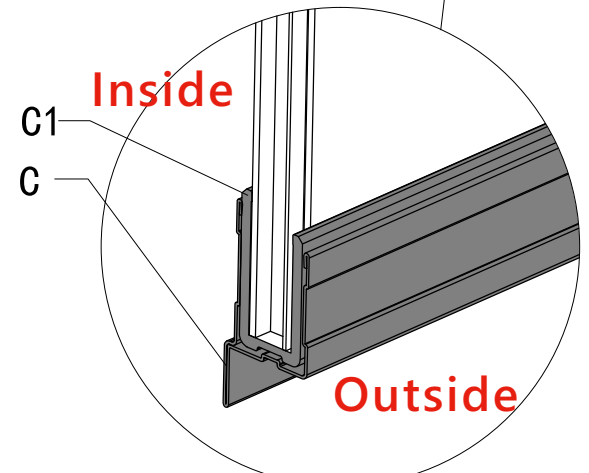
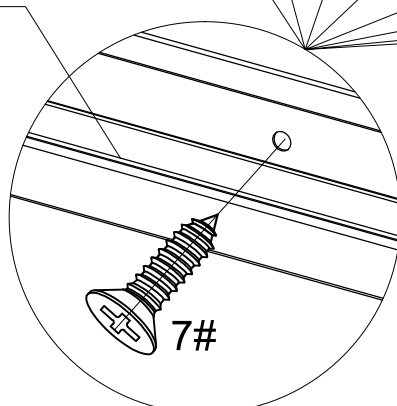
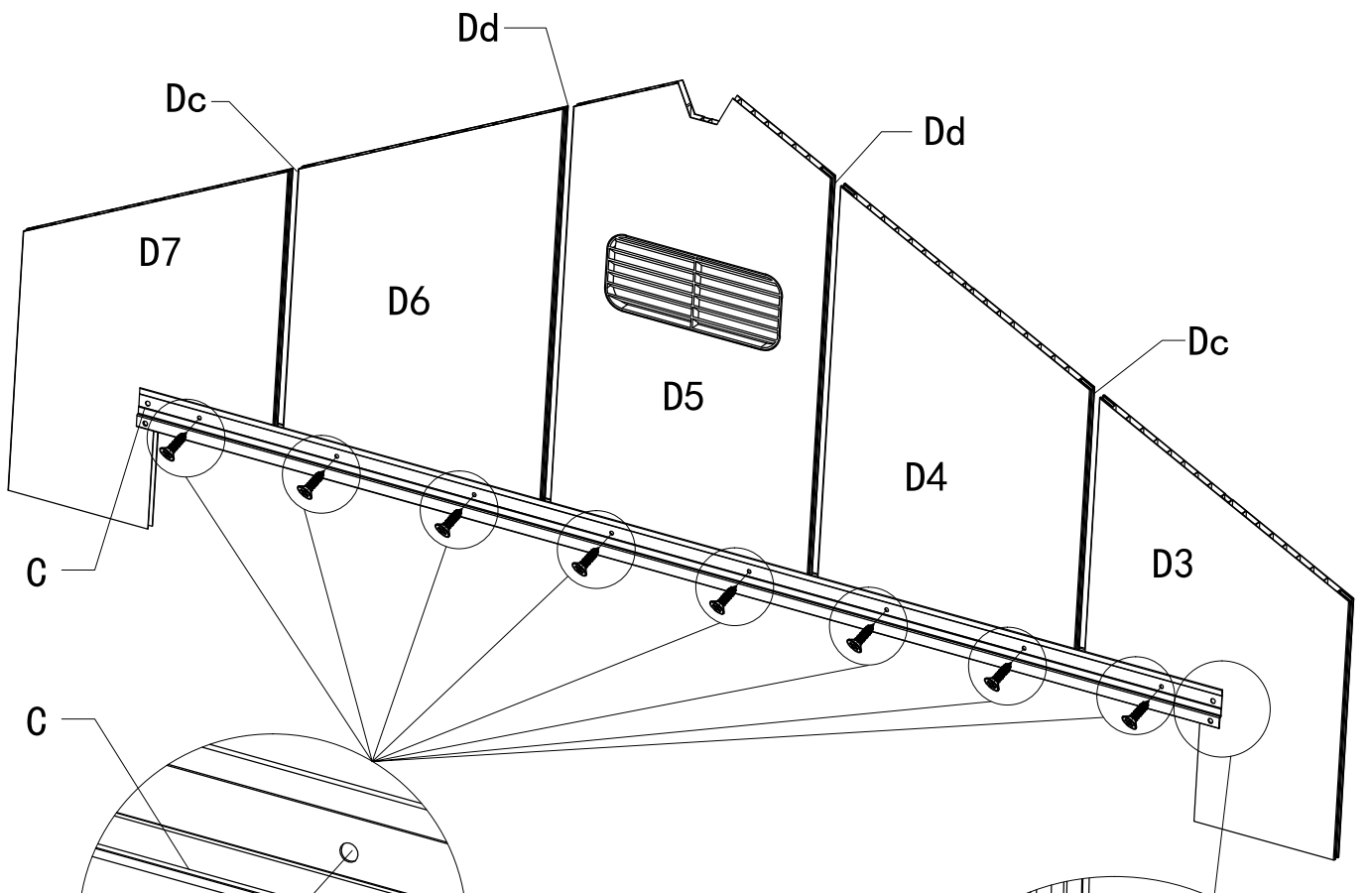
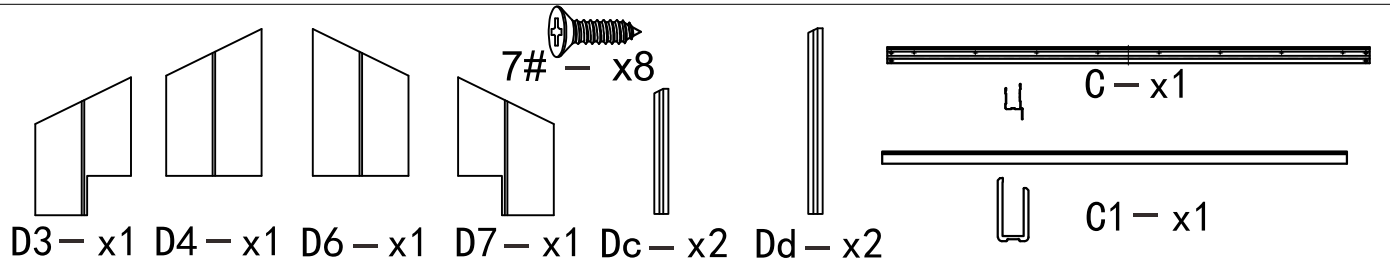

Fit the plastic frame liner #C1 and the metal frame #C into the wall panel as shown.



Ø5 Q4 - x1



4x10
8# - x12

7# - x16



M5x25
13# - x4

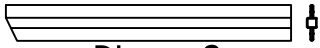

Db - x2

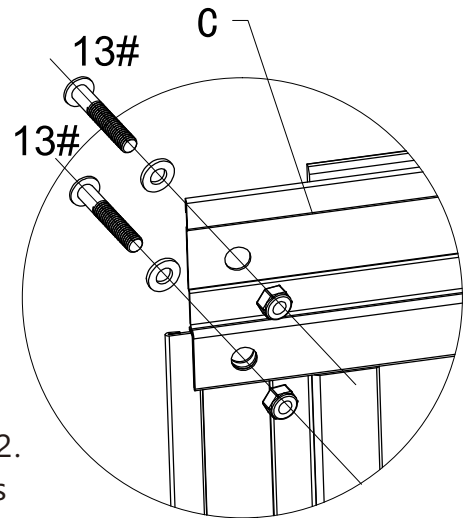
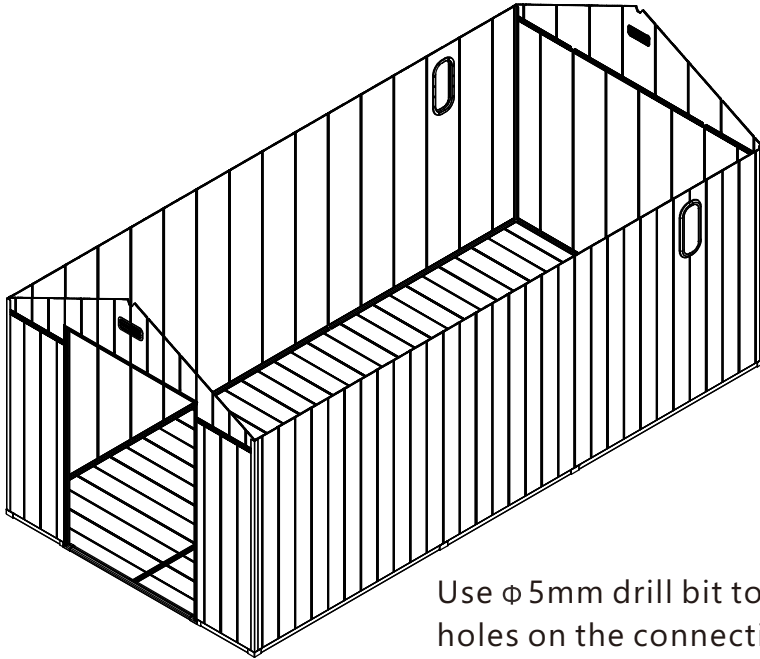

Use ϕ 5mm drill bit to drill holes on the connection of top beam #C and #B1/B2. Secure with 1 bolt, washers and nuts #13. Repeat above procedures to assemble other sides.

Inside View

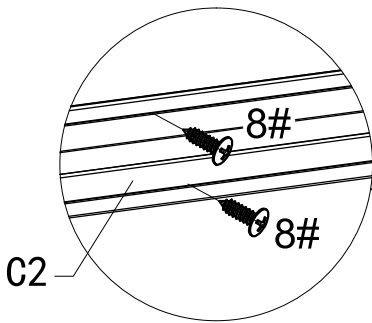

C2

C2

Use 12 screws 8# to secure top frame #C2 with front wall panels.

Use 16 screws 7# to secure #B1, B2 with front wall panels.

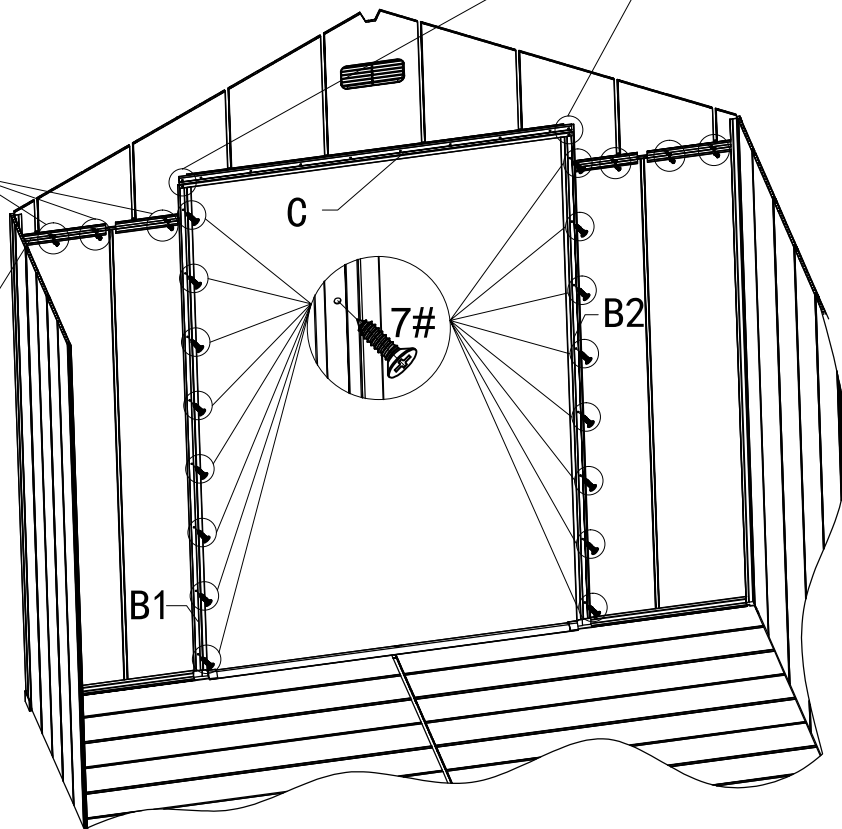

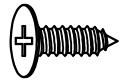

4x9

5# - x28

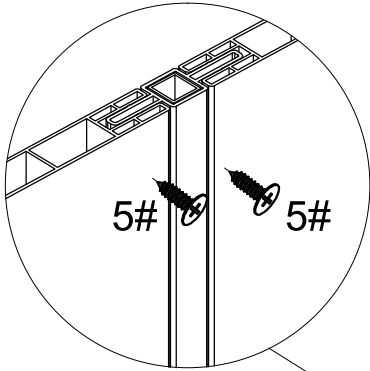

Use 28 screws 5# to secure the panels with connecting rods.

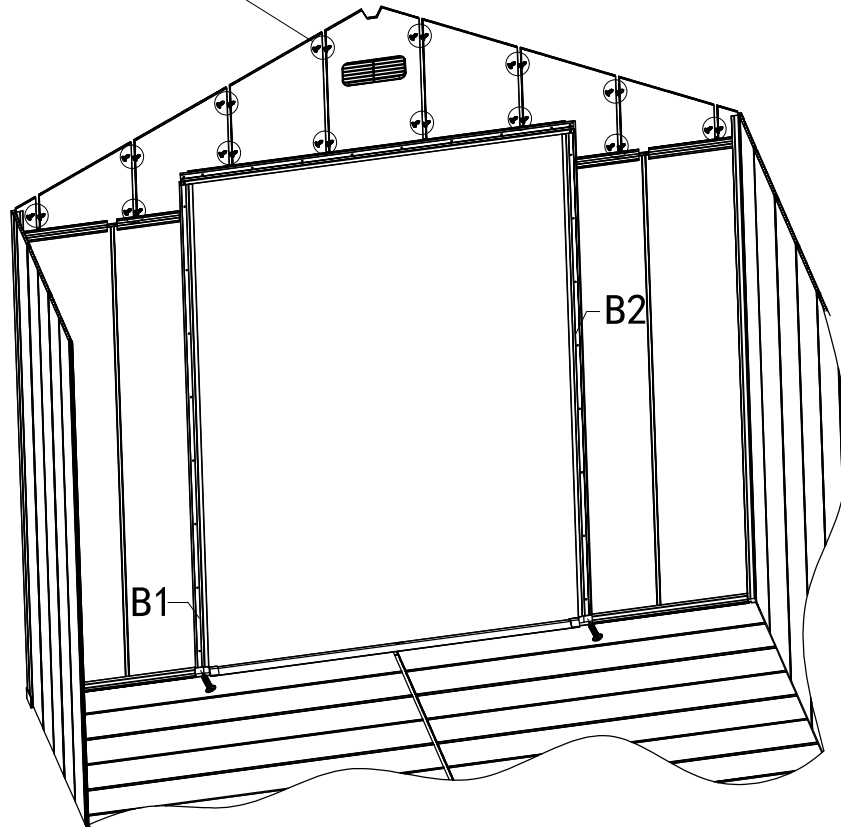



Ø3
Q3 - x1



4x14
6# - x2

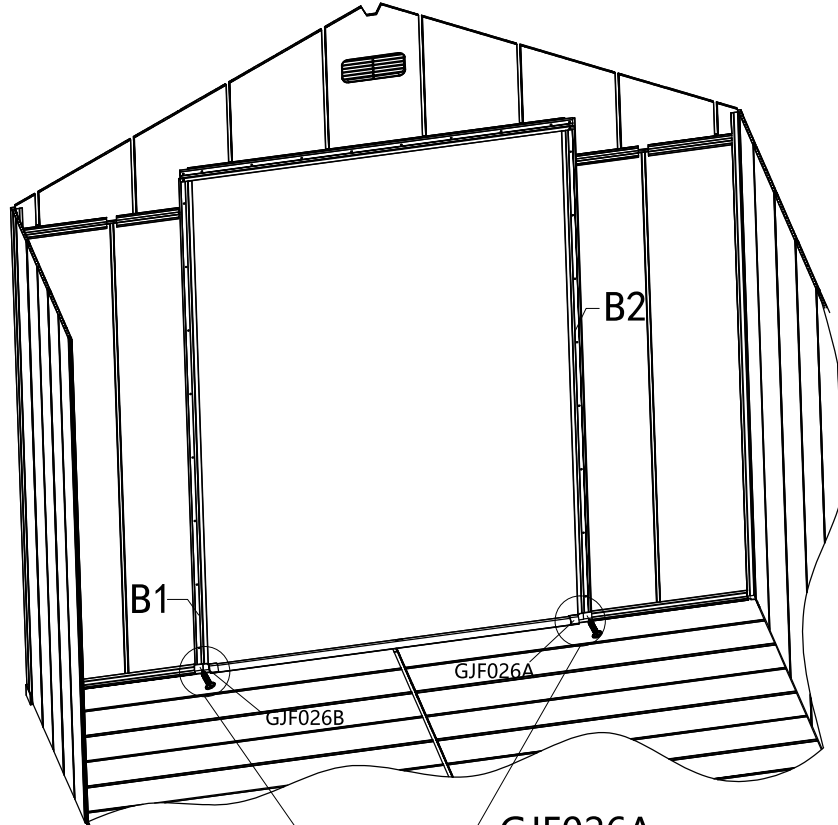

GJF026A
GJF026B

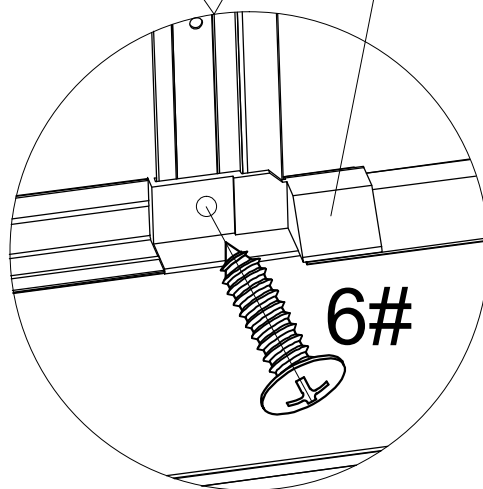

Use $\Phi 3.0$ mm drill bit to drill holes on the connecting kits and door frame #B1/B2 first.

Note: Drill holes only on the inner edges of the metal door frames #B1/#B2, do not drill all the way through.

Secure with Screw #6.

M5x8
1# — x40

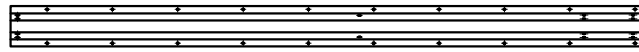

F — x1



F1 — x2

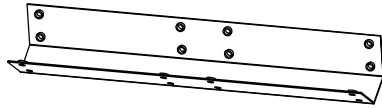

F2 — x2

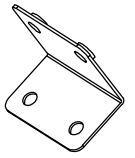

F3 — x4

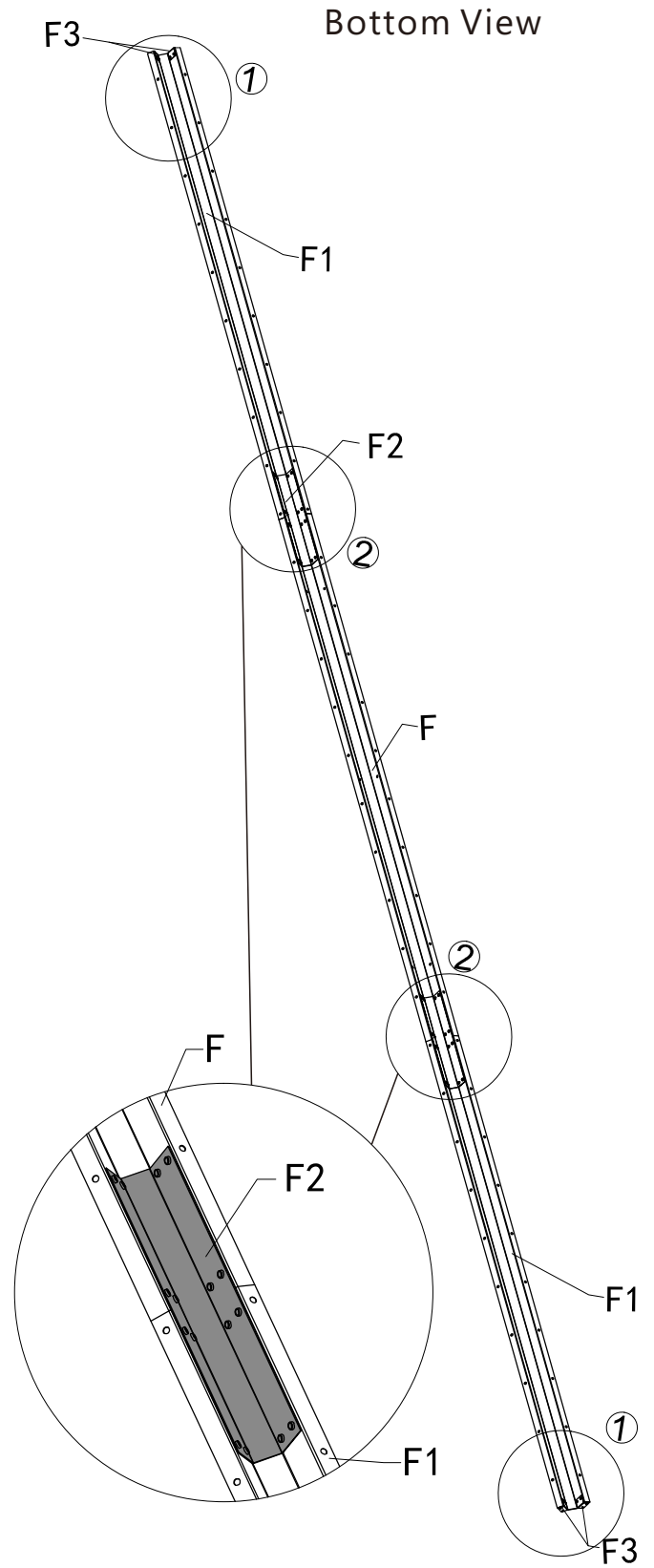
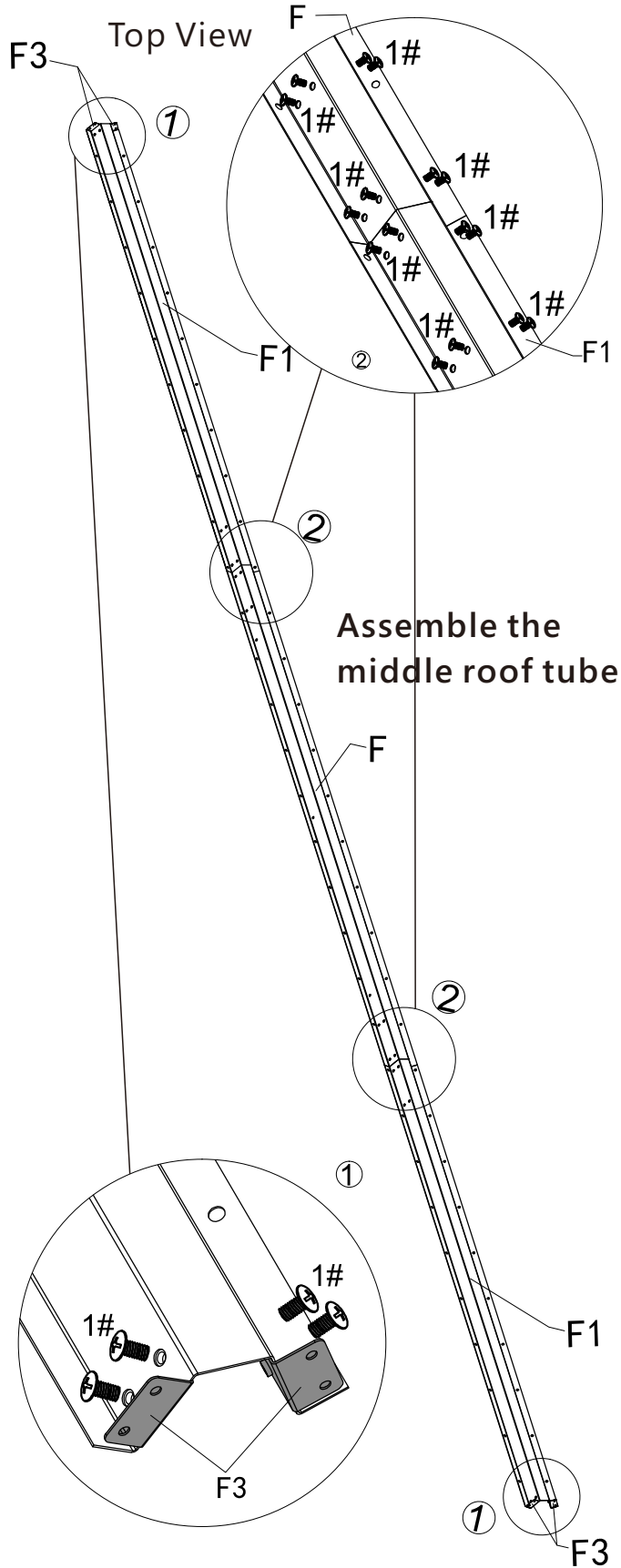

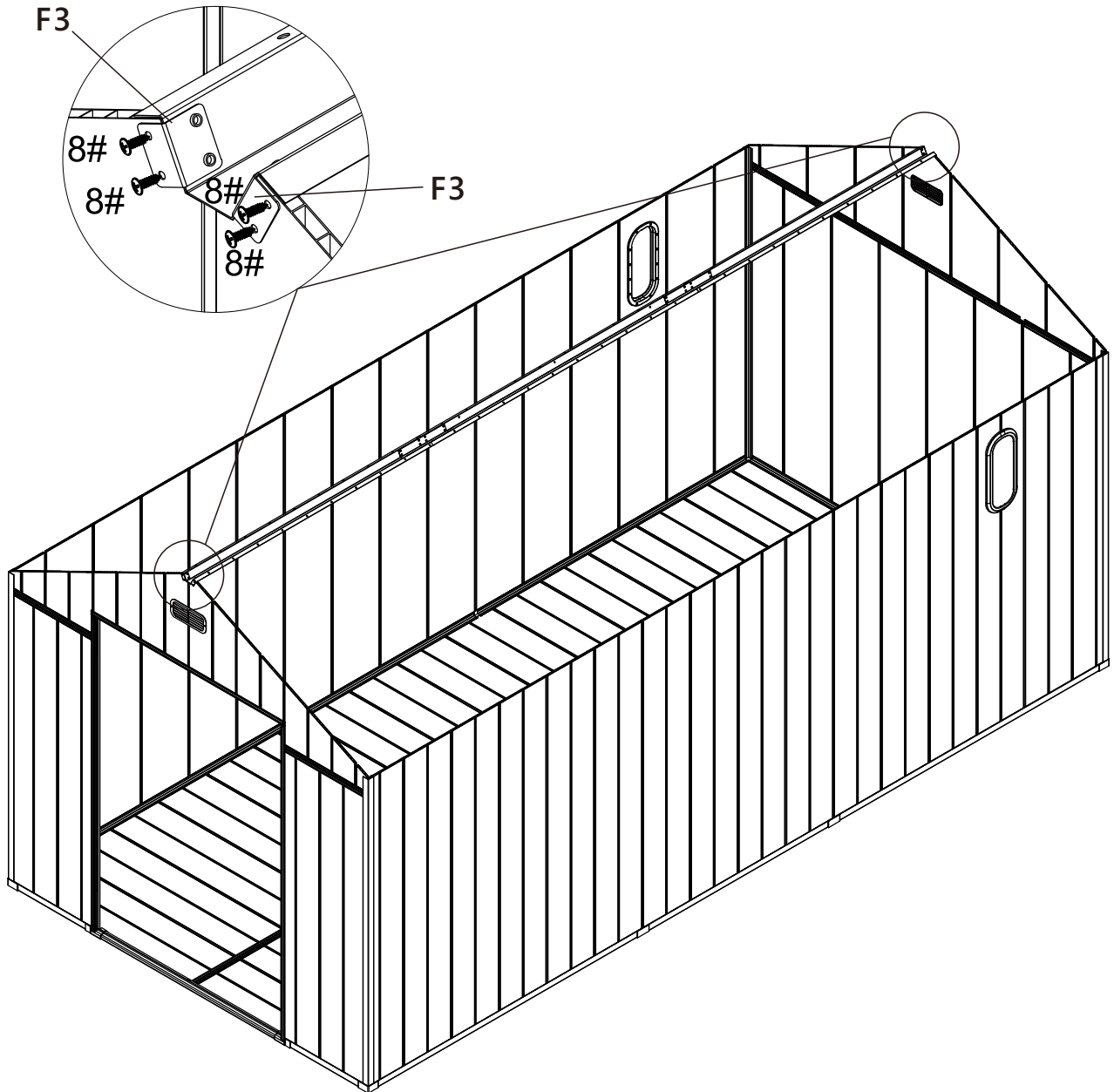

4x10
8# – x8

Use 8 screws #8 to secure the middle roof tube to the wall panel.

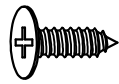

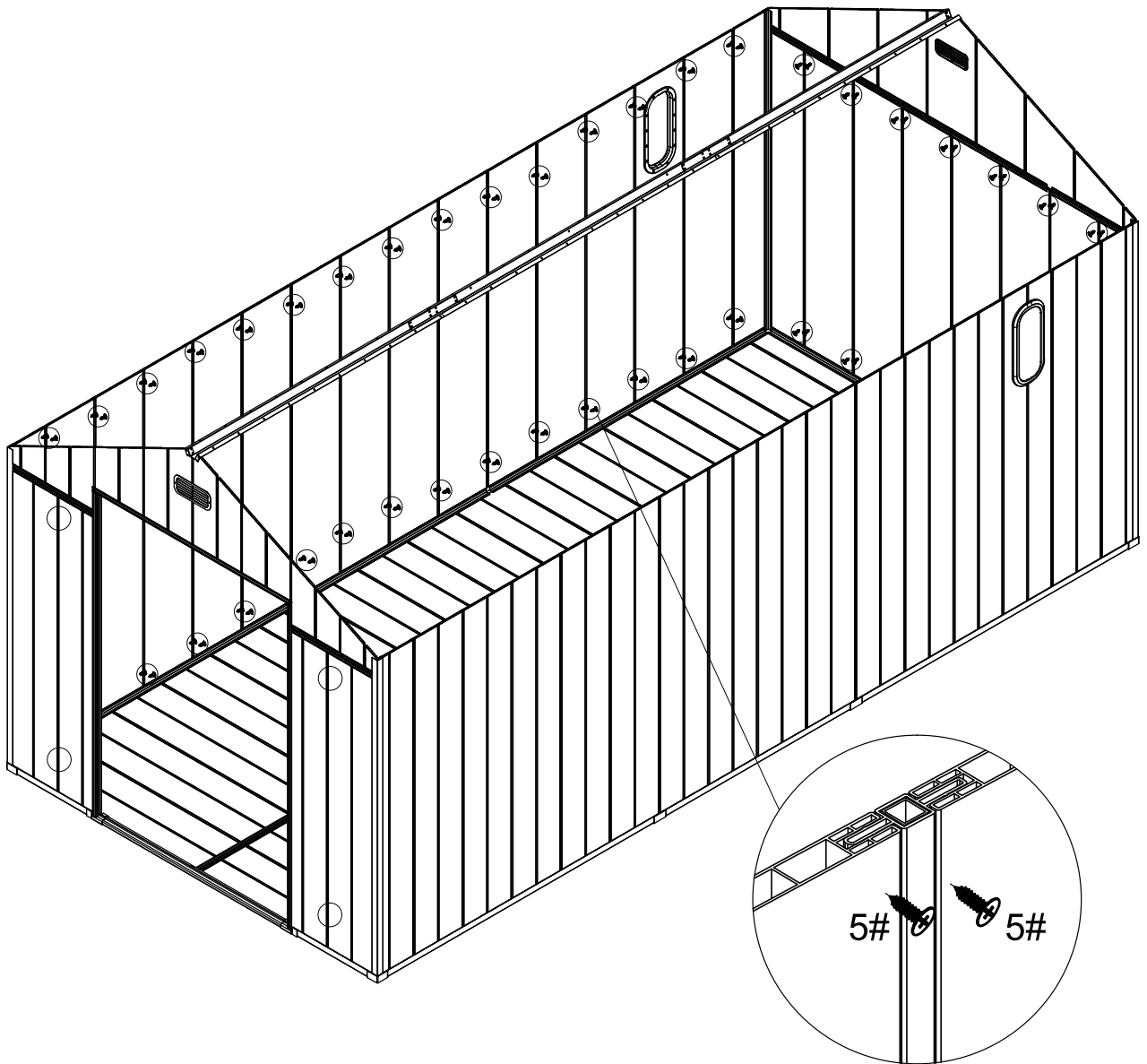

4x9
5# - x156



Use 156 screws 5# to secure the wall panels to the connecting rods.



4x10
8# — x48

Use 12 screws #8 to secure the corner support tubes #B with the corner wall panels. Repeat above steps to assemble other corners.

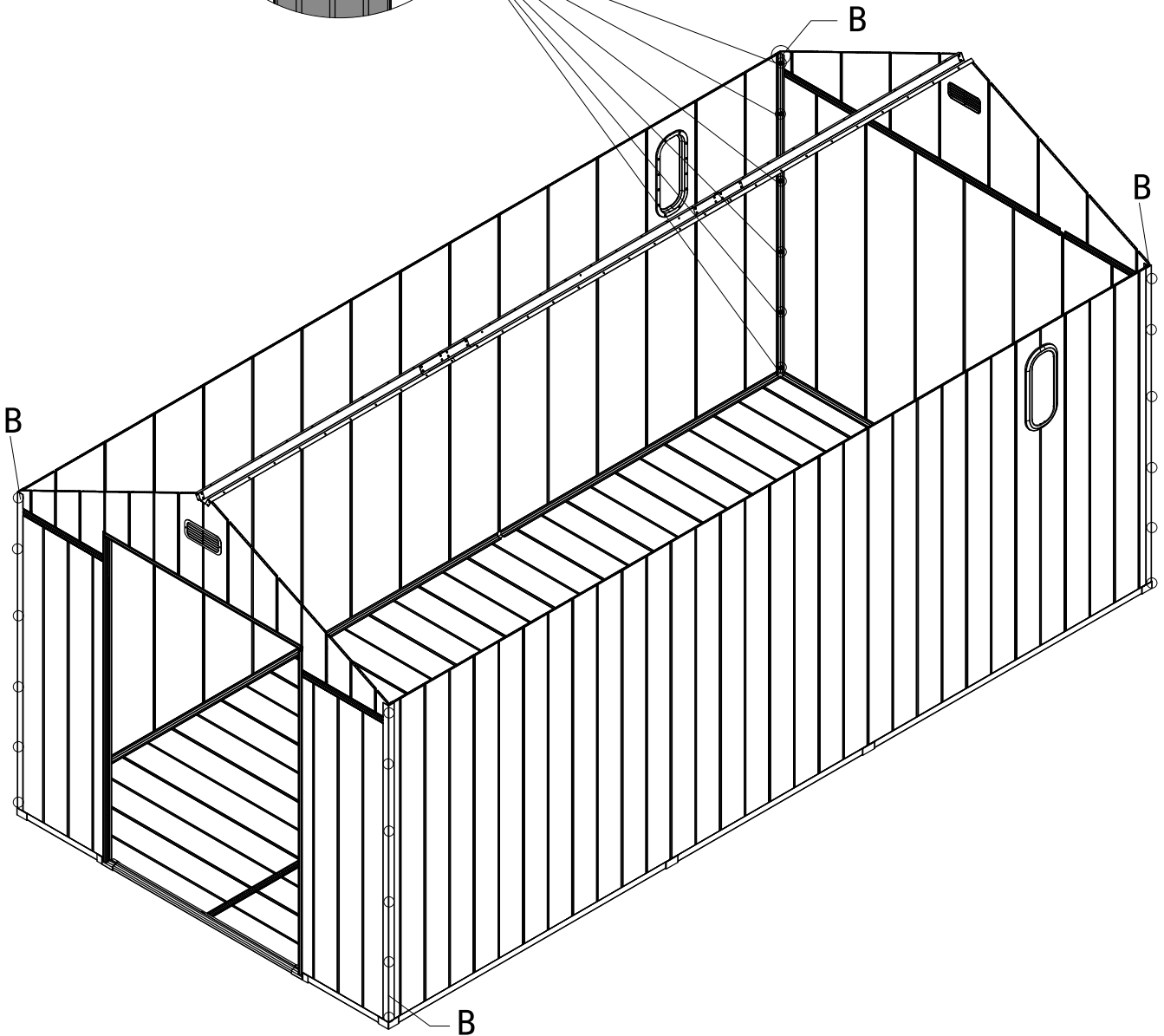
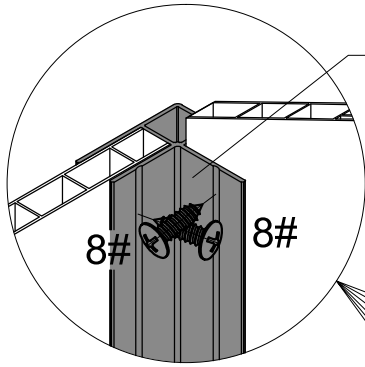

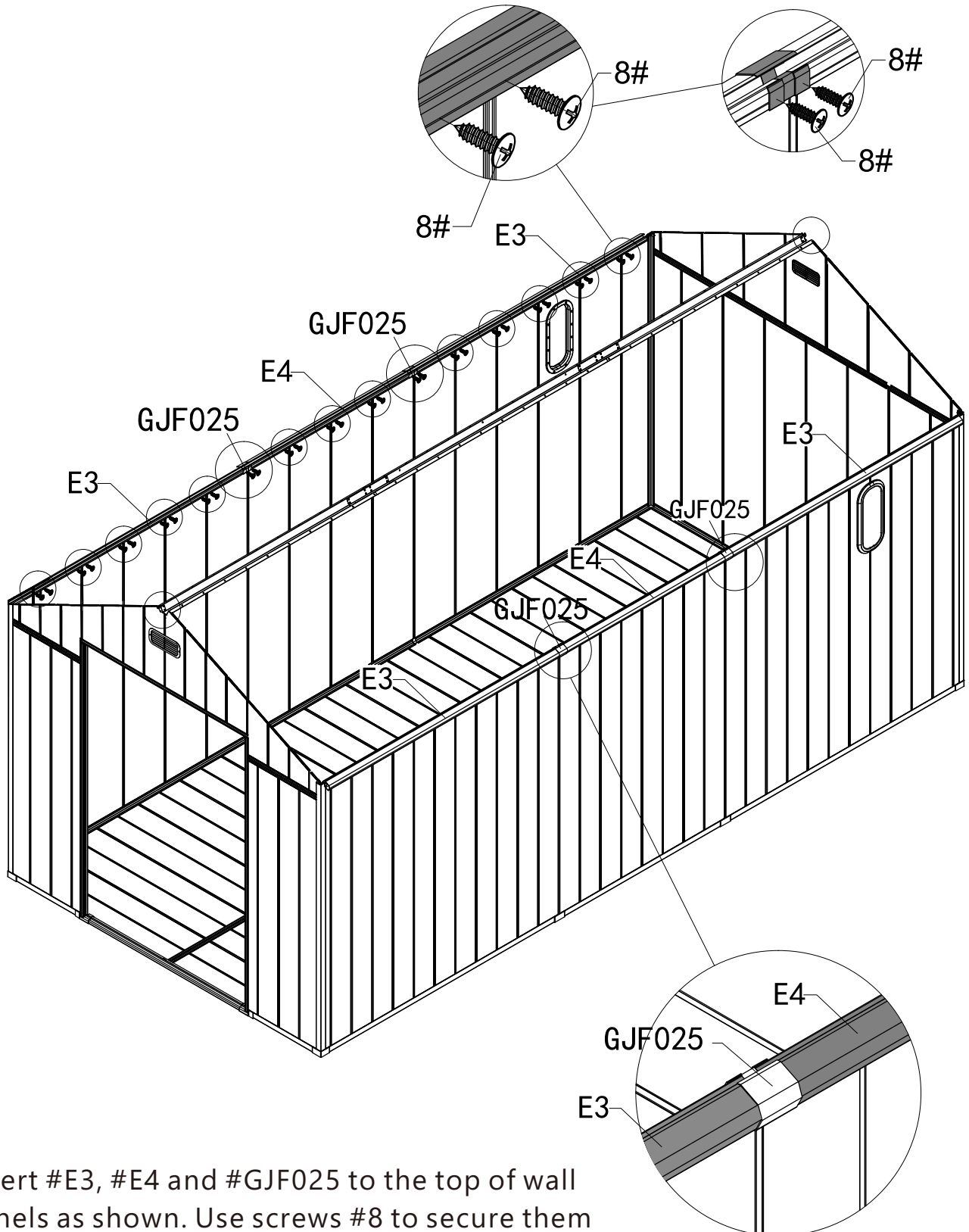
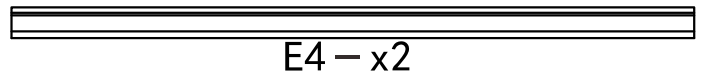

Insert #E3, #E4 and #GJF025 to the top of wall panels as shown. Use screws #8 to secure them to the connecting rods in the wall.

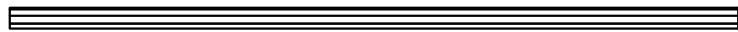

F4 - x4

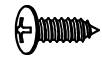

8# - x28

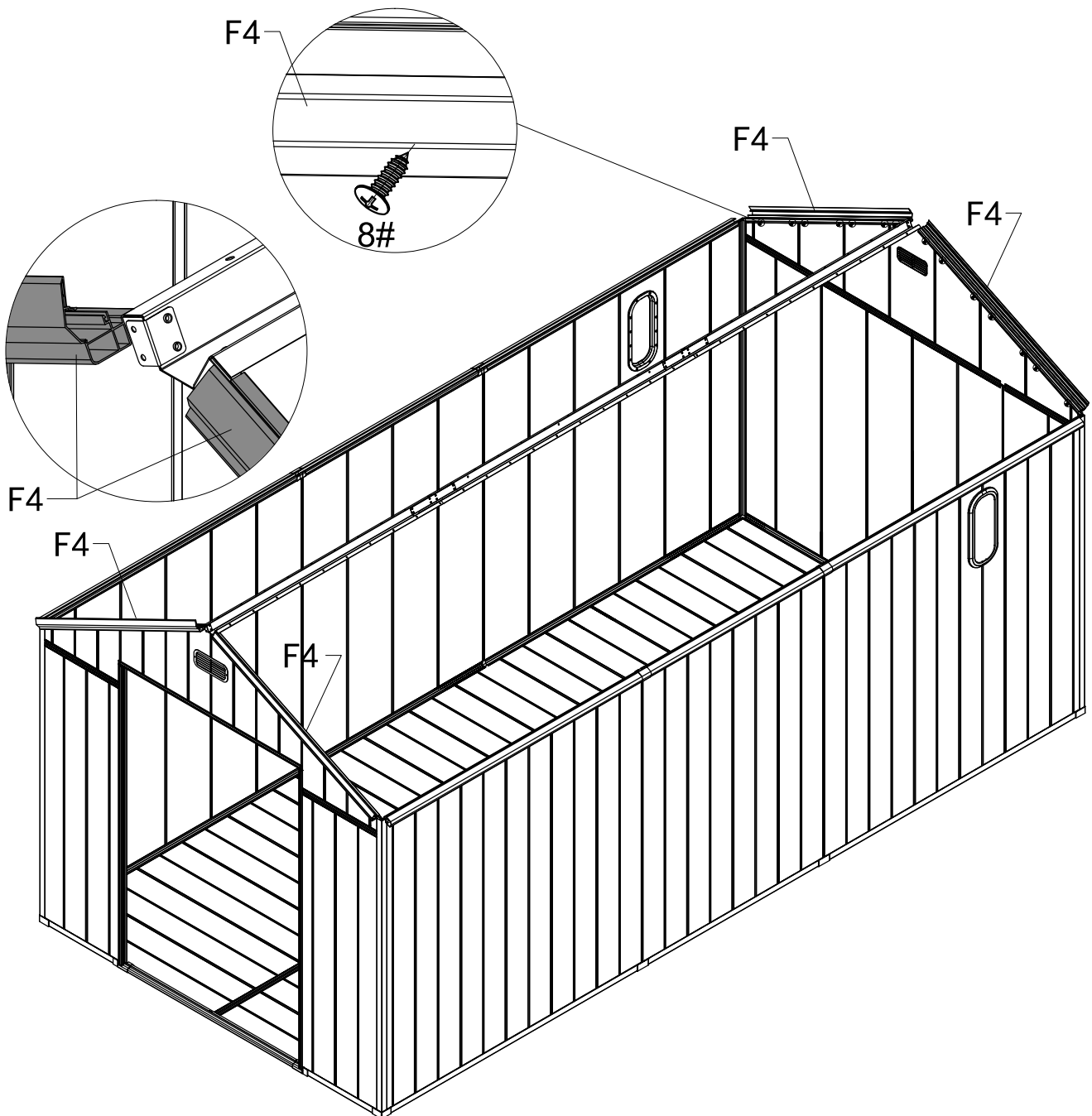

Insert and secure 4 #F4 to wall panel with 7 screws #8(from inside).
Repeat above steps to assemble the other 3 sides.

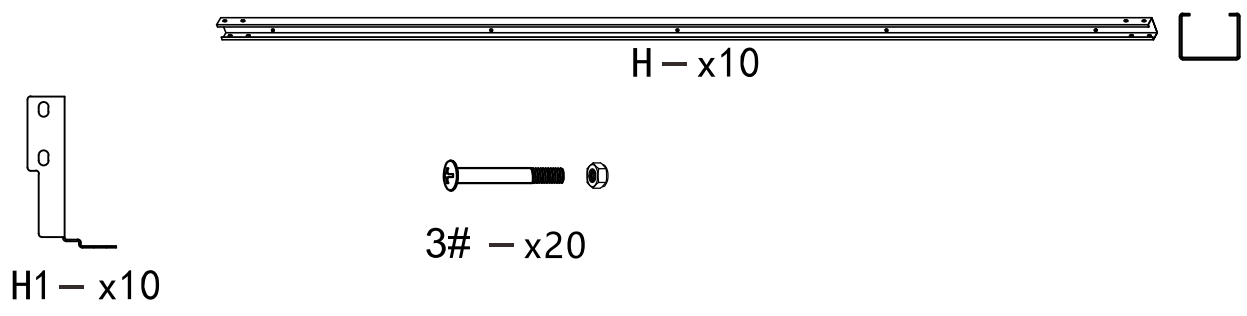

SECTION VIEW

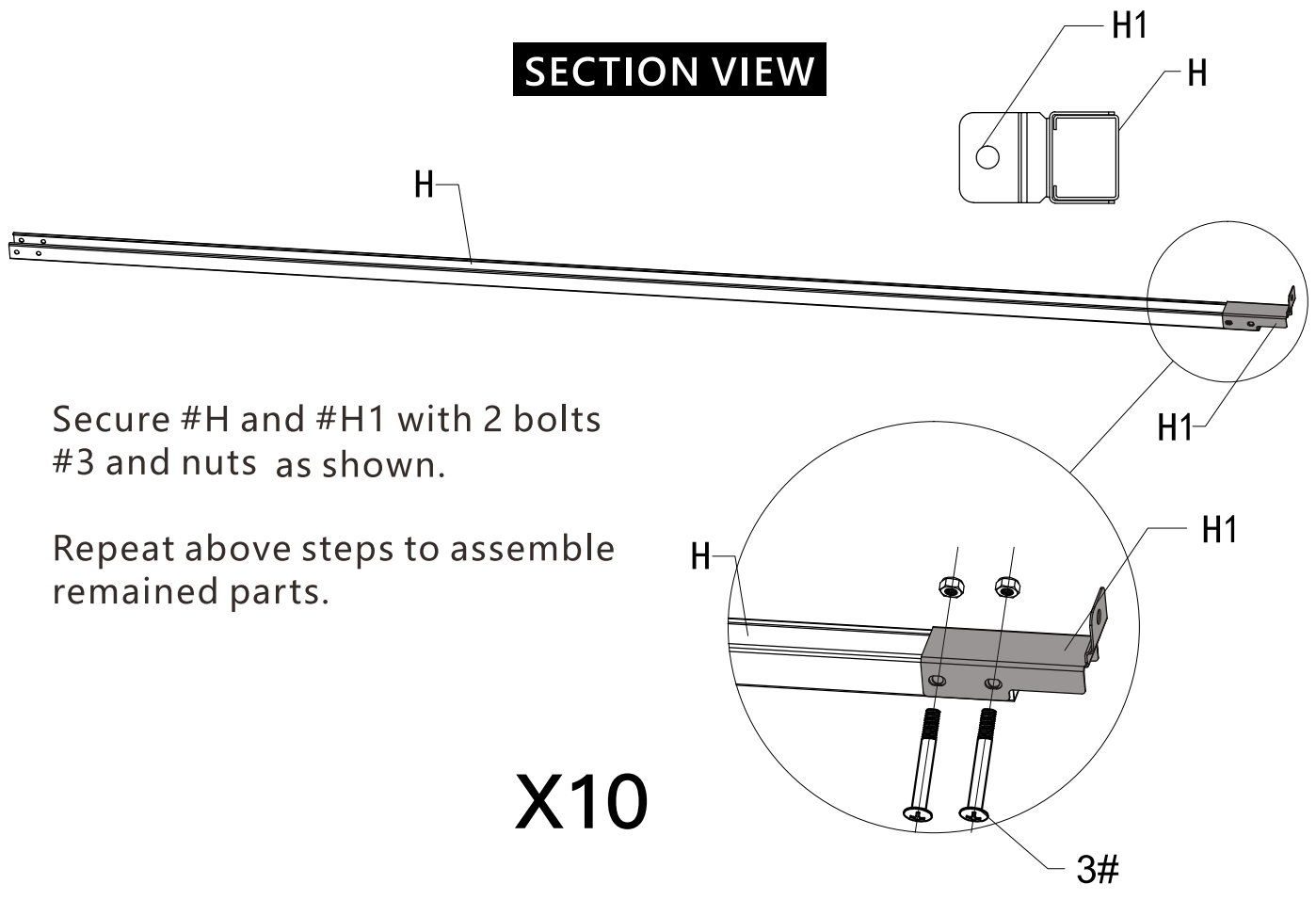

Secure #H and #H1 with 2 bolts #3 and nuts as shown.

Repeat above steps to assemble remained parts.

X10

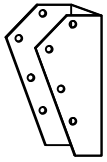

K - x10

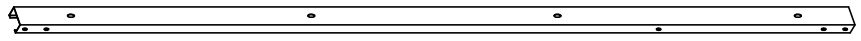

J - x10



3# - x20

x10

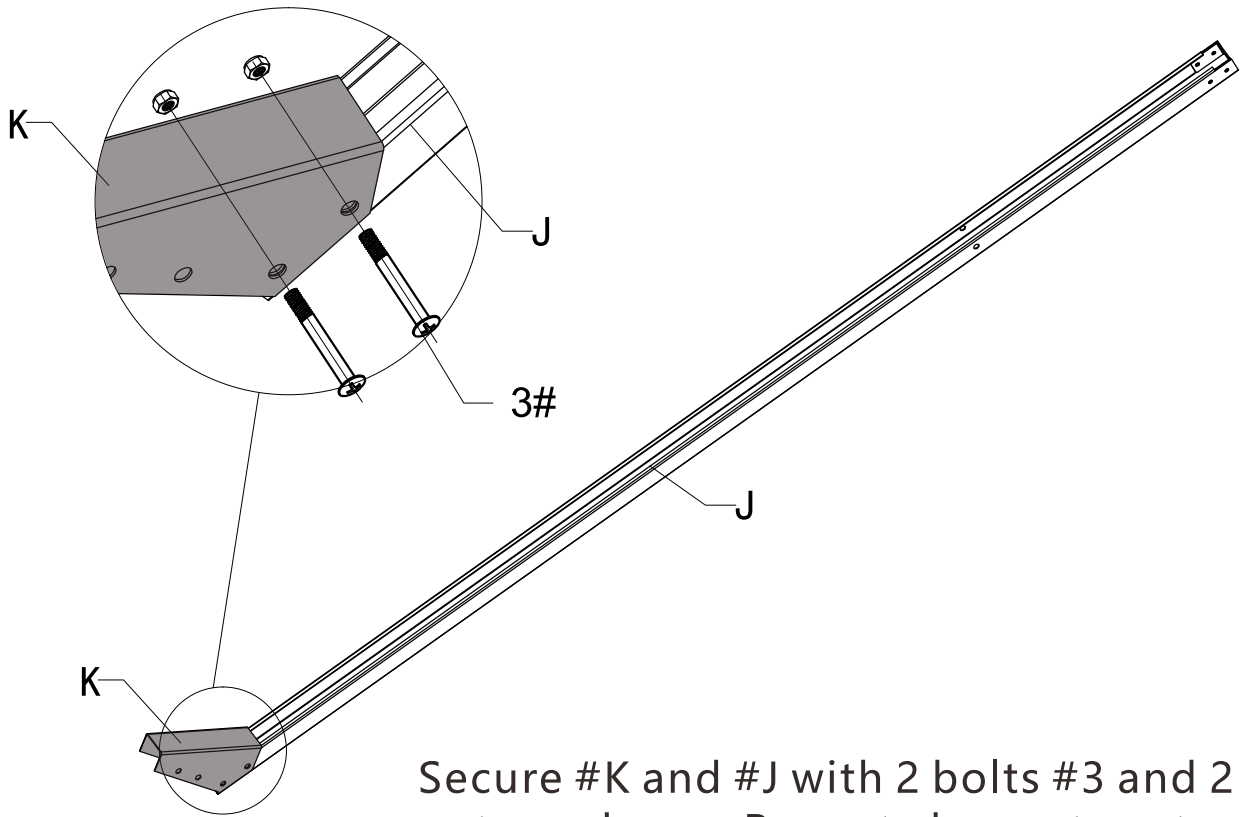

Secure #K and #J with 2 bolts #3 and 2 nuts as shown. Repeat above steps to assemble the remained parts

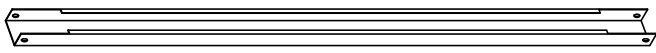

J1 - x5



8# - x50



1# - x10



3# - x30



Ø3

Q3 - x1

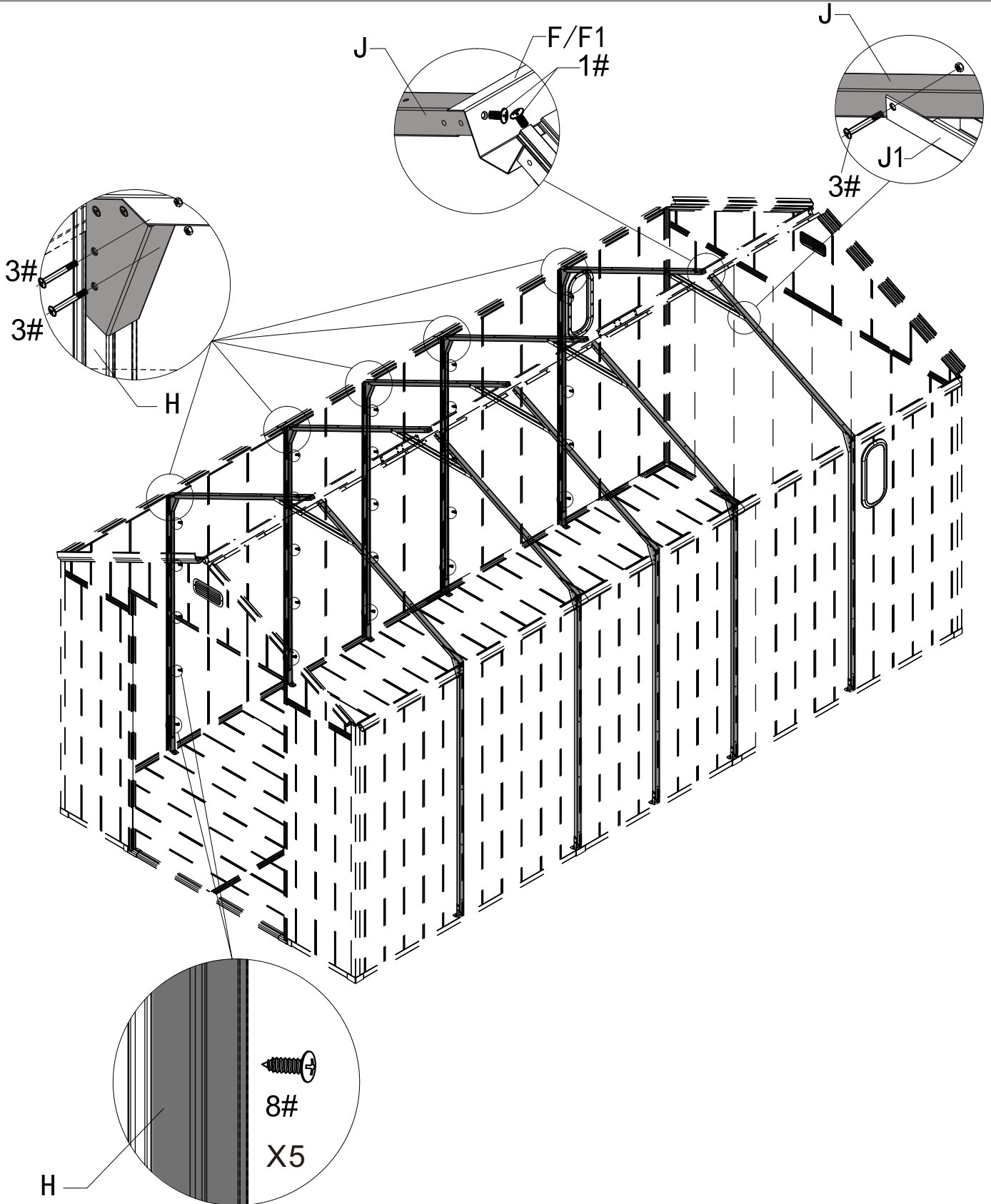

Assemble the support tubes:

- ①: Use bolts #1 to secure part #J to middle roof tube.
- ②: Secure bracket #K and support pole #H with 2 bolts and nuts #3.
- ③: Use bolts and nuts #3 to connect each #J with connecting tube #J1.
- ④: Secure support pole #H to the centre of the connecting rods with 5 screws #8 (Since the inner linings of the connecting rods are fitted with metal tubes, it is necessary to pre-drill the screw holes with a 3 mm-diameter drill bit before installing the #8 screws.).

Repeat the above steps to assemble the other sides.

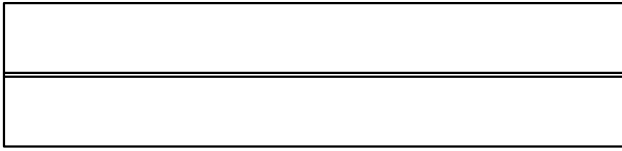

G-x28

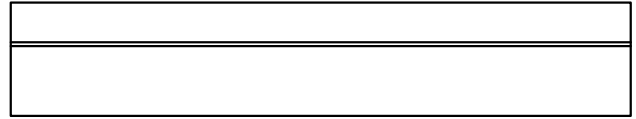

G1-x4



G2-x30

Insert roof panels to the groove of wall covers #E3,E4.

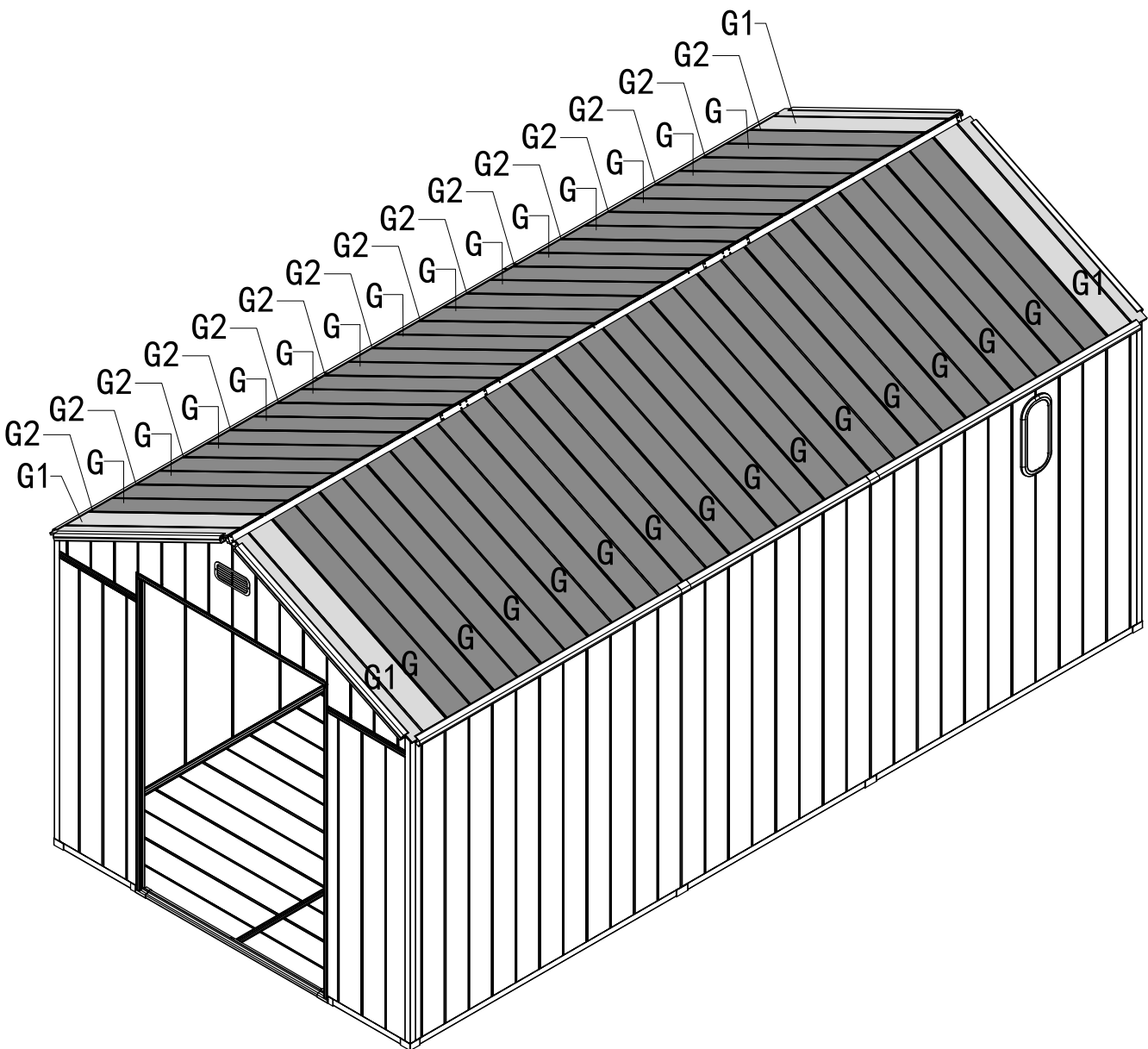



8# - x40



Ø3
Q3 - x1

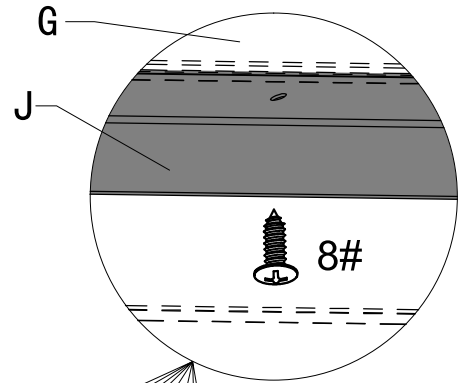

Use 8 screws 8# to secure part #J to the connecting rods in the roof.
Repeat above process to assemble the other parts.

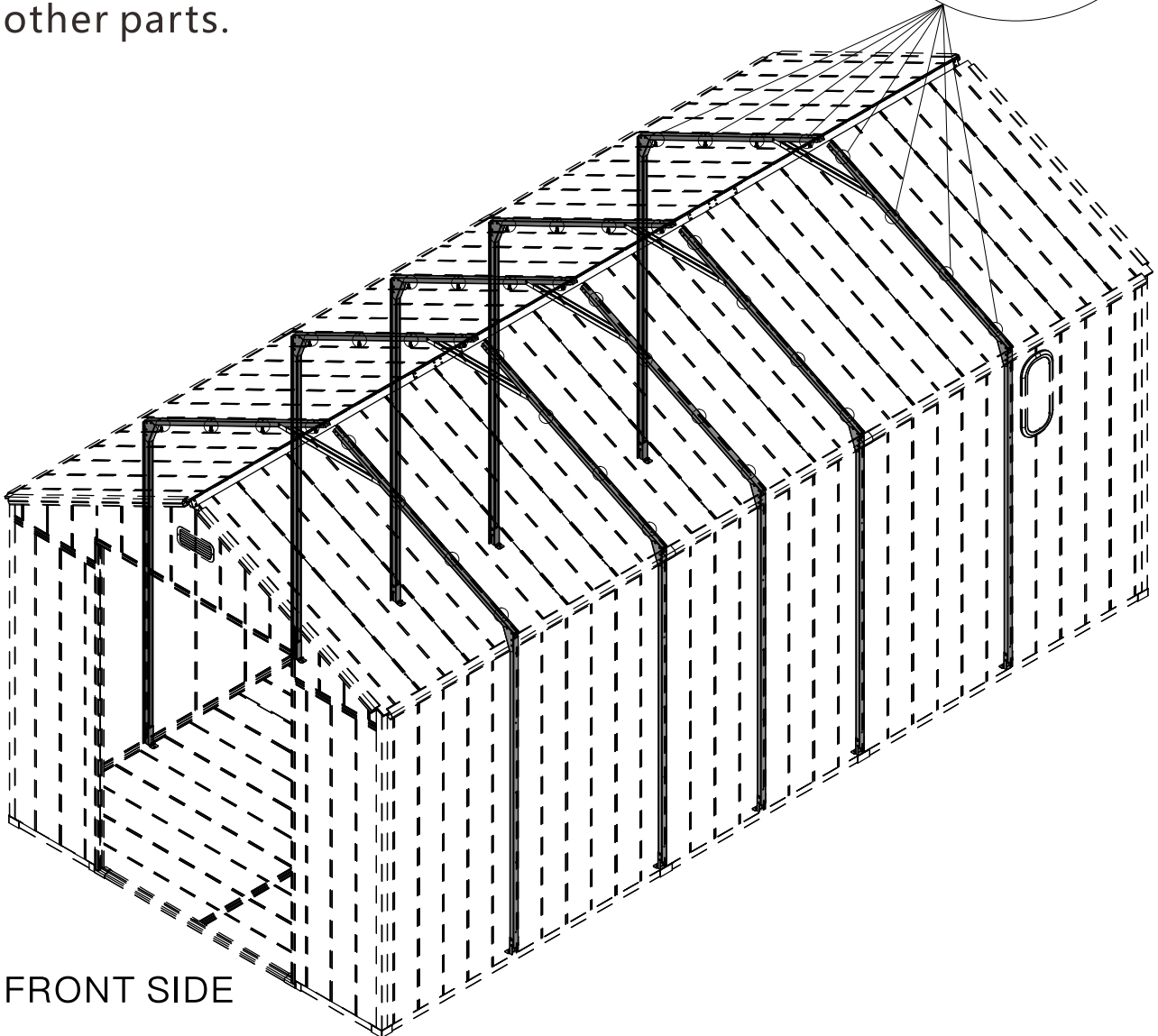

FRONT SIDE

Since the inner linings of the connecting rods are fitted with metal tubes, it is necessary to pre-drill the screw holes with a 3 mm-diameter drill bit before installing the #8 screws.



6# - x12

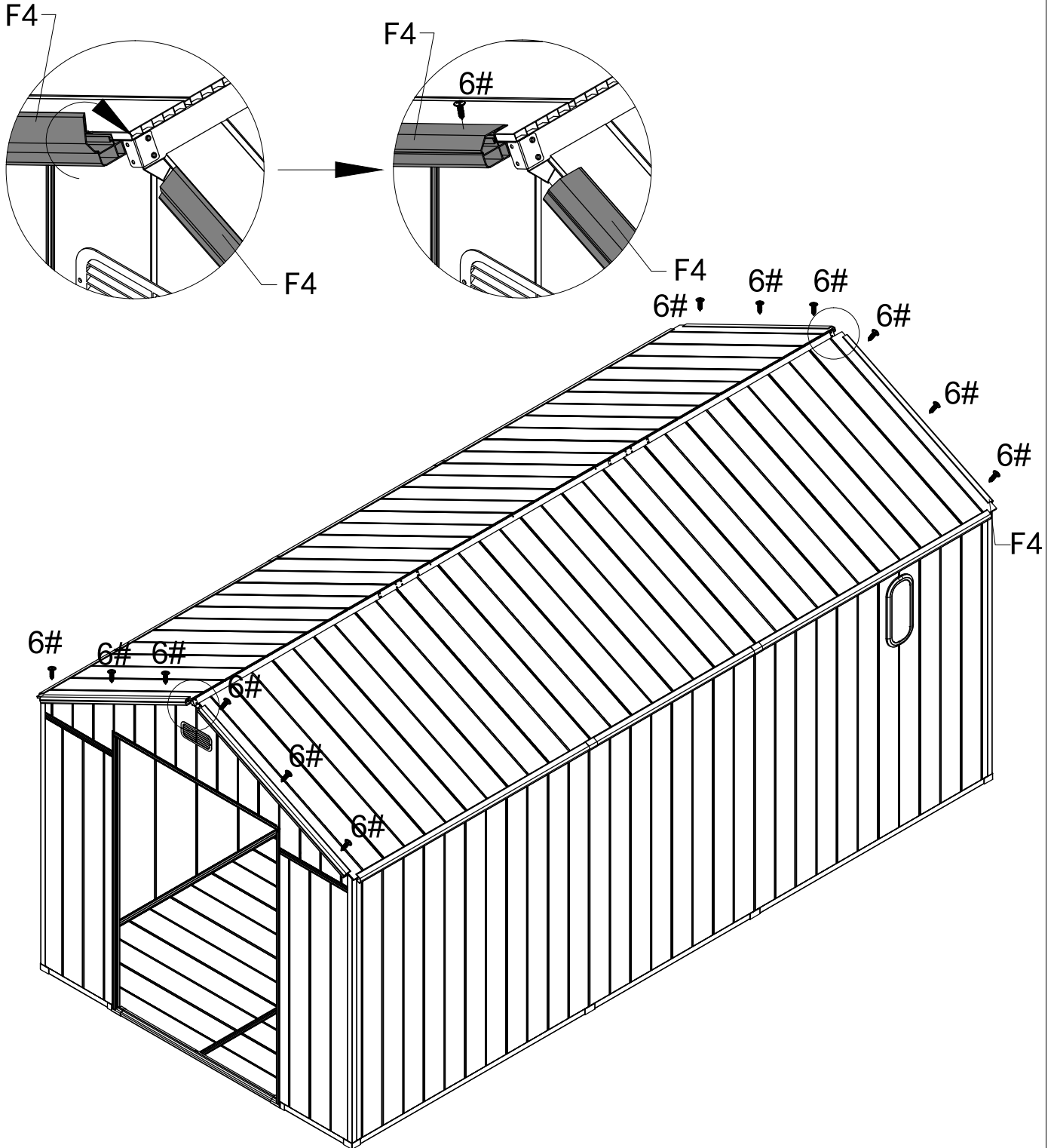

Fit the upper half of #F4 tightly over the roof panel #G1, then secure it with screws #6.



8# - x60

Bottom View

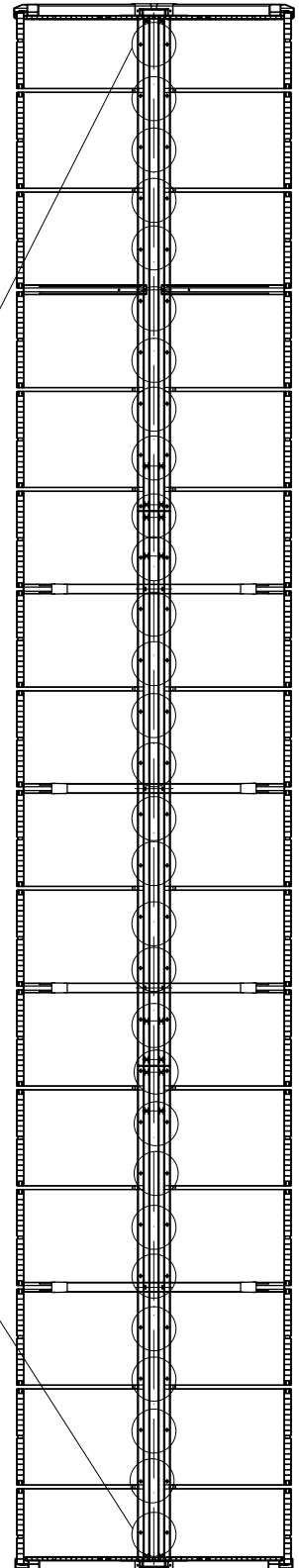
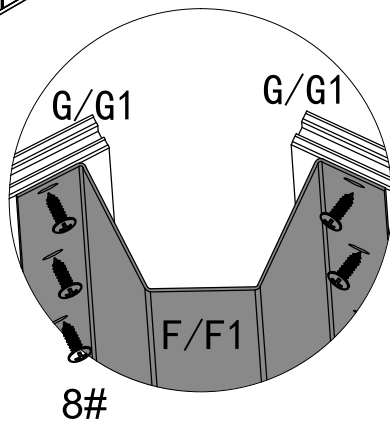
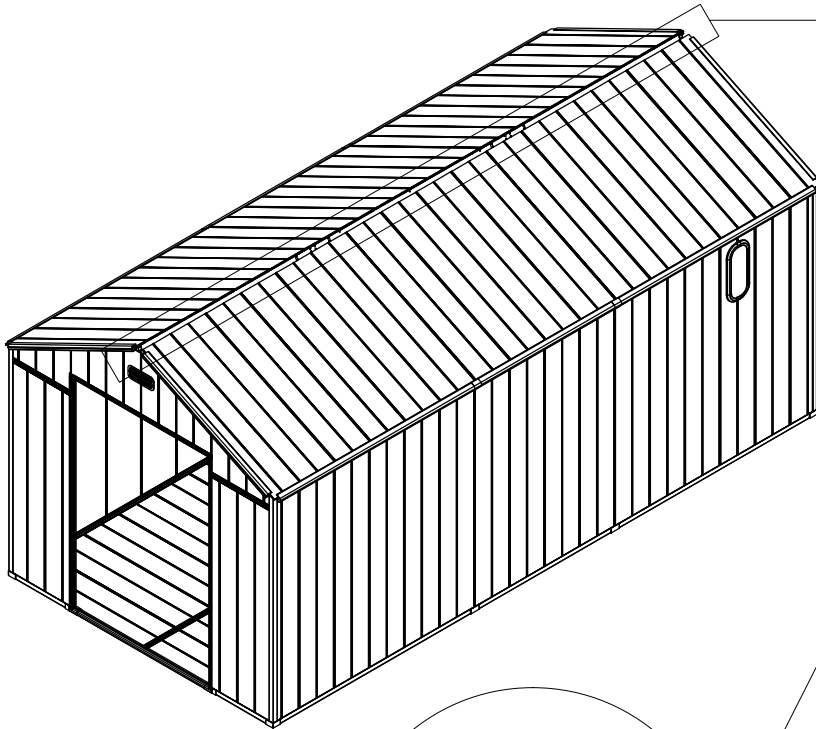

Use 60 screws #8 to secure the middle roof tube #F/F1 to the roof panels.

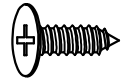

4x9
5# - x120

Use 120 screws #5 to secure the roof panels with connect rods #G2 from inside.

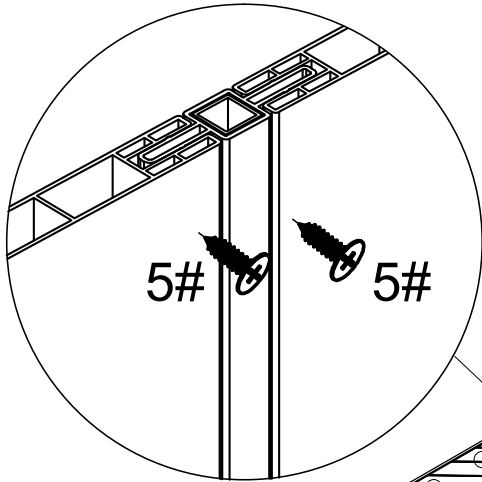

Inside View

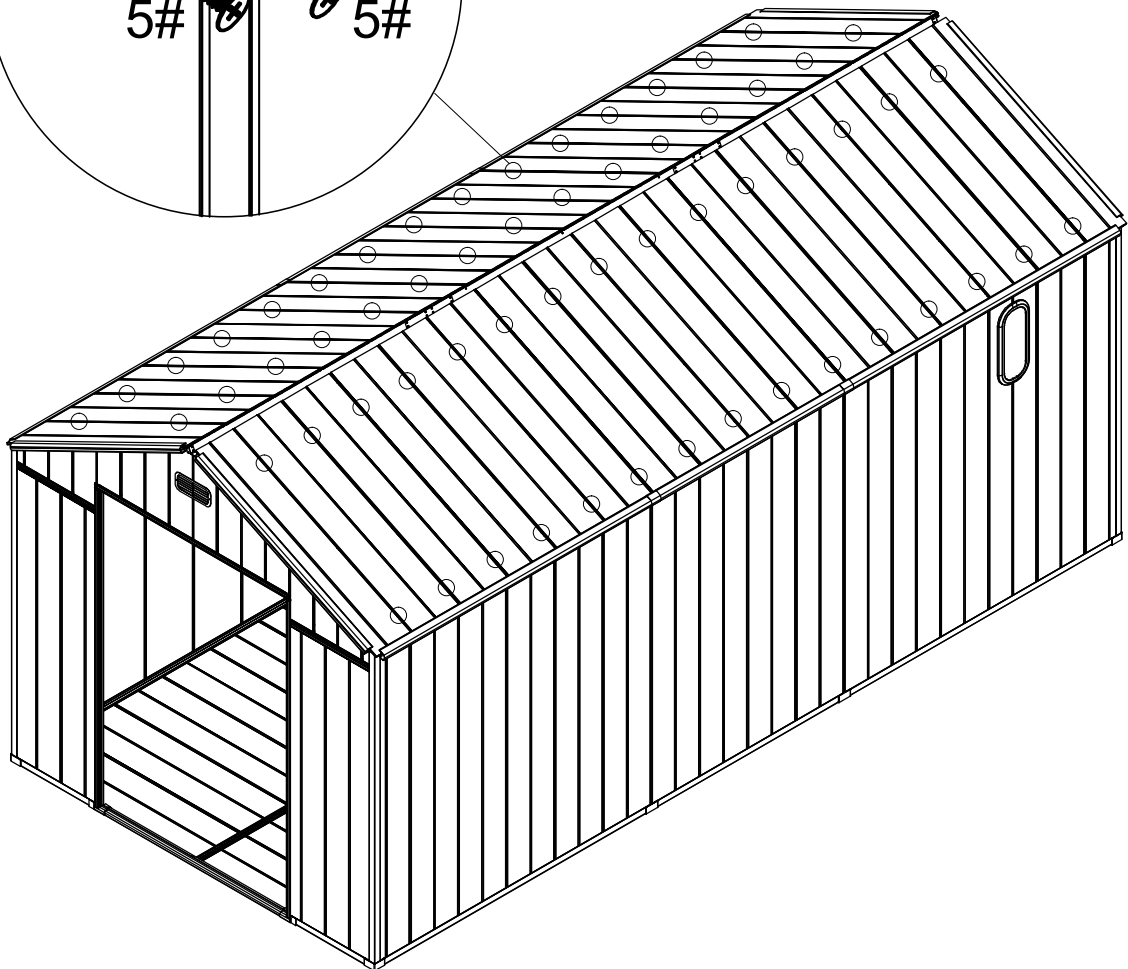

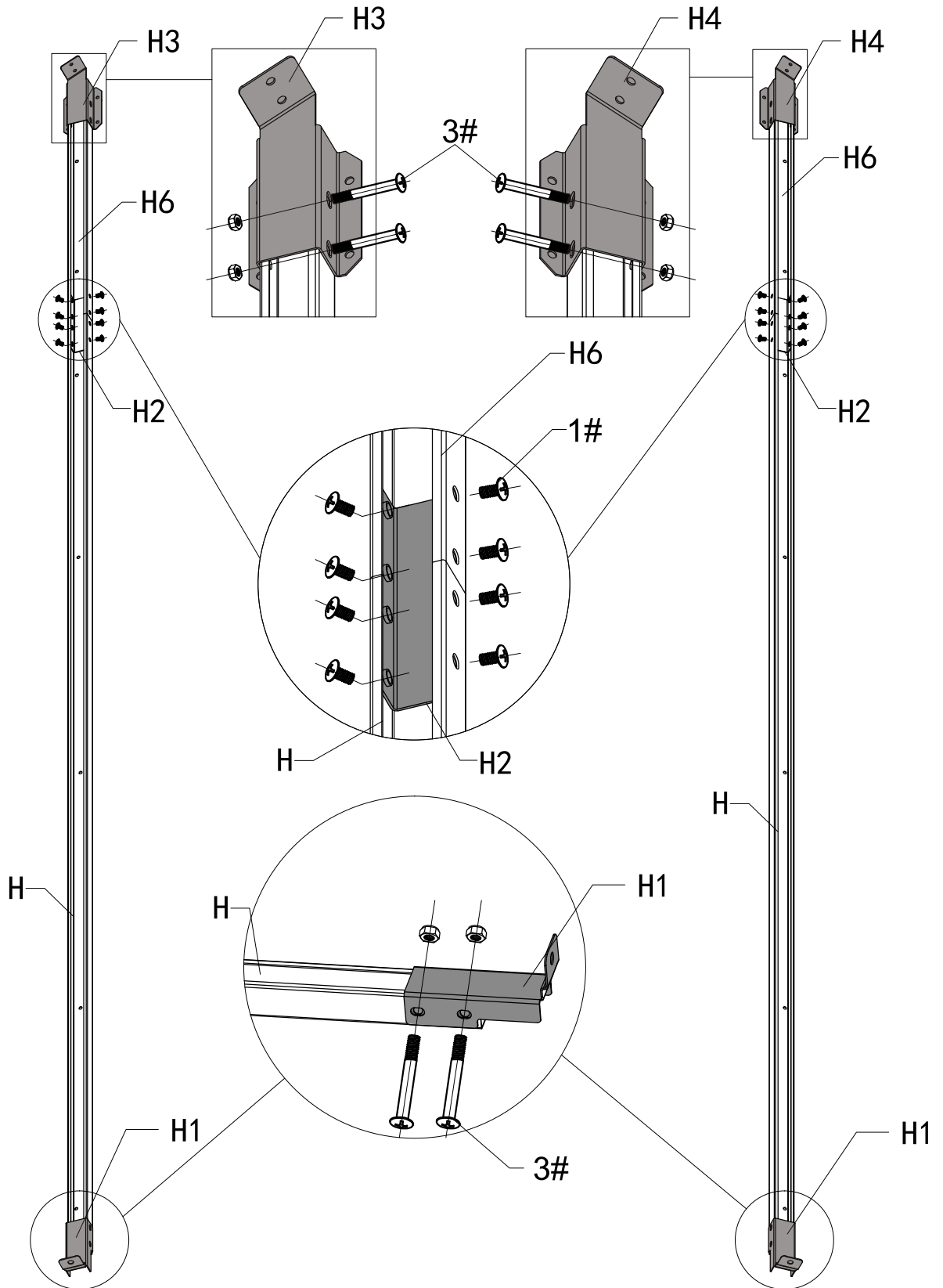
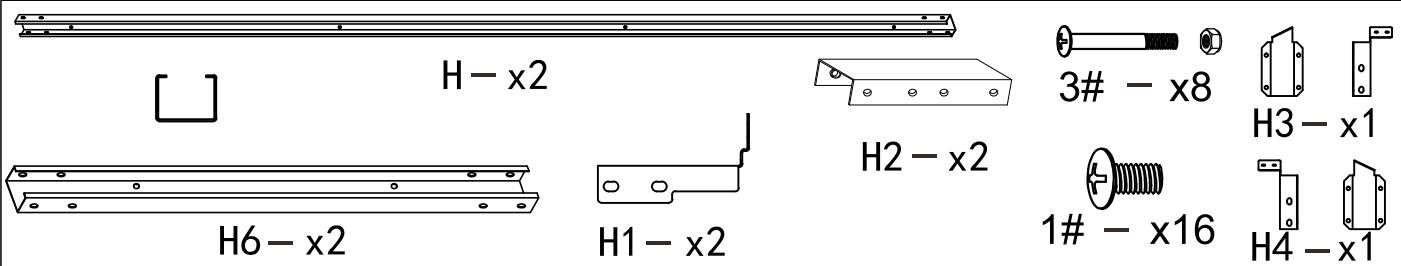

Rear Supporting Pole Assembly



8# - x30



Ø3
Q3 - x1

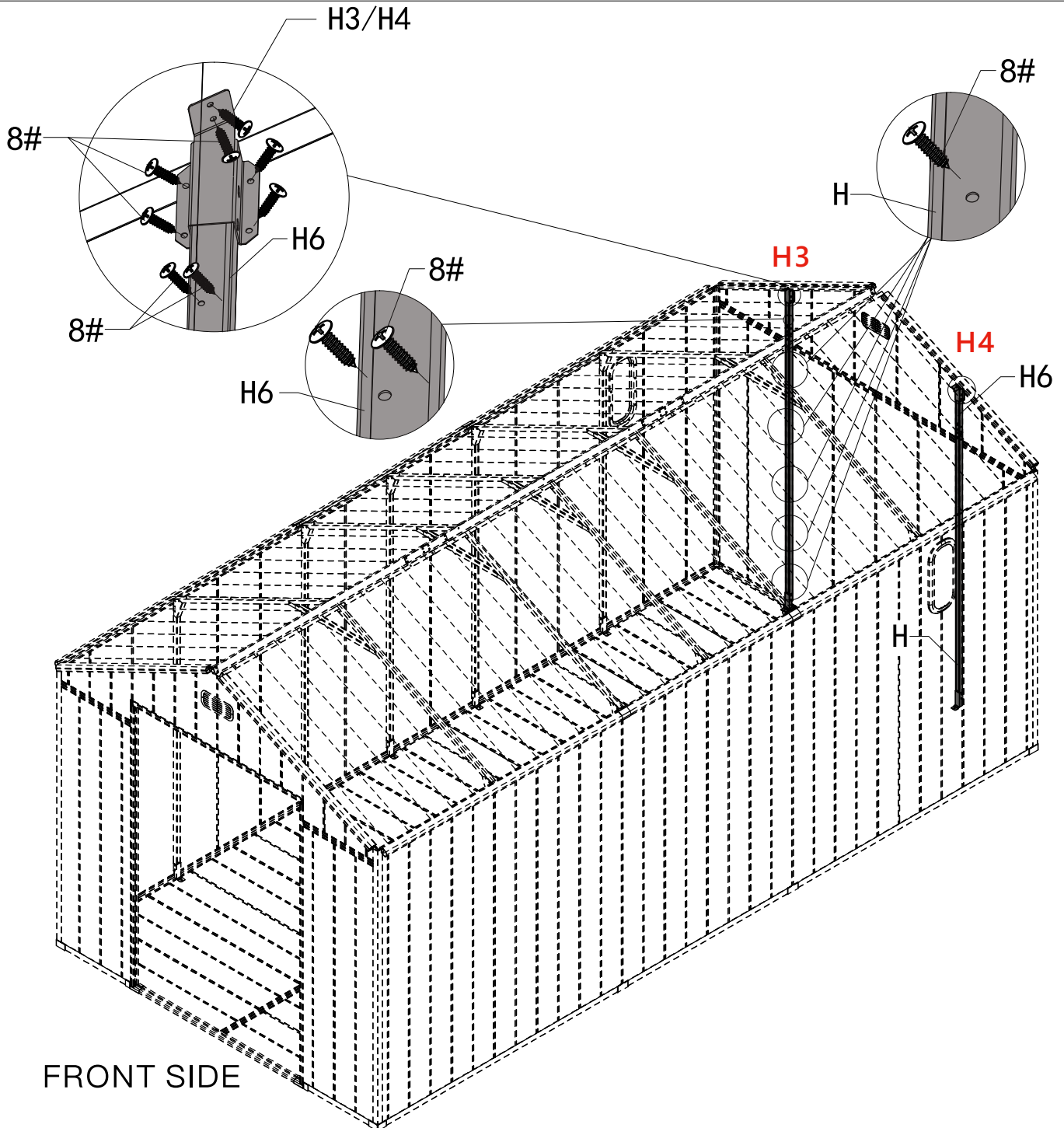

FRONT SIDE

Use 6 screws #8 to Secure bracket #H3/#H4 to roof panels(2 screws)and wall panels(4 screws).

Use 4 screws #8 to Secure supporting pole #H6 to wall panels.

Use 5 screws #8 to Secure supporting pole #H to the centre of the connecting rods(Since the inner linings of the connecting rods are fitted with metal tubes, it is necessary to pre-drill the screw holes with a 3 mm-diameter drill bit before installing the #8 screws.).

Repeat above process to assemble the other side.

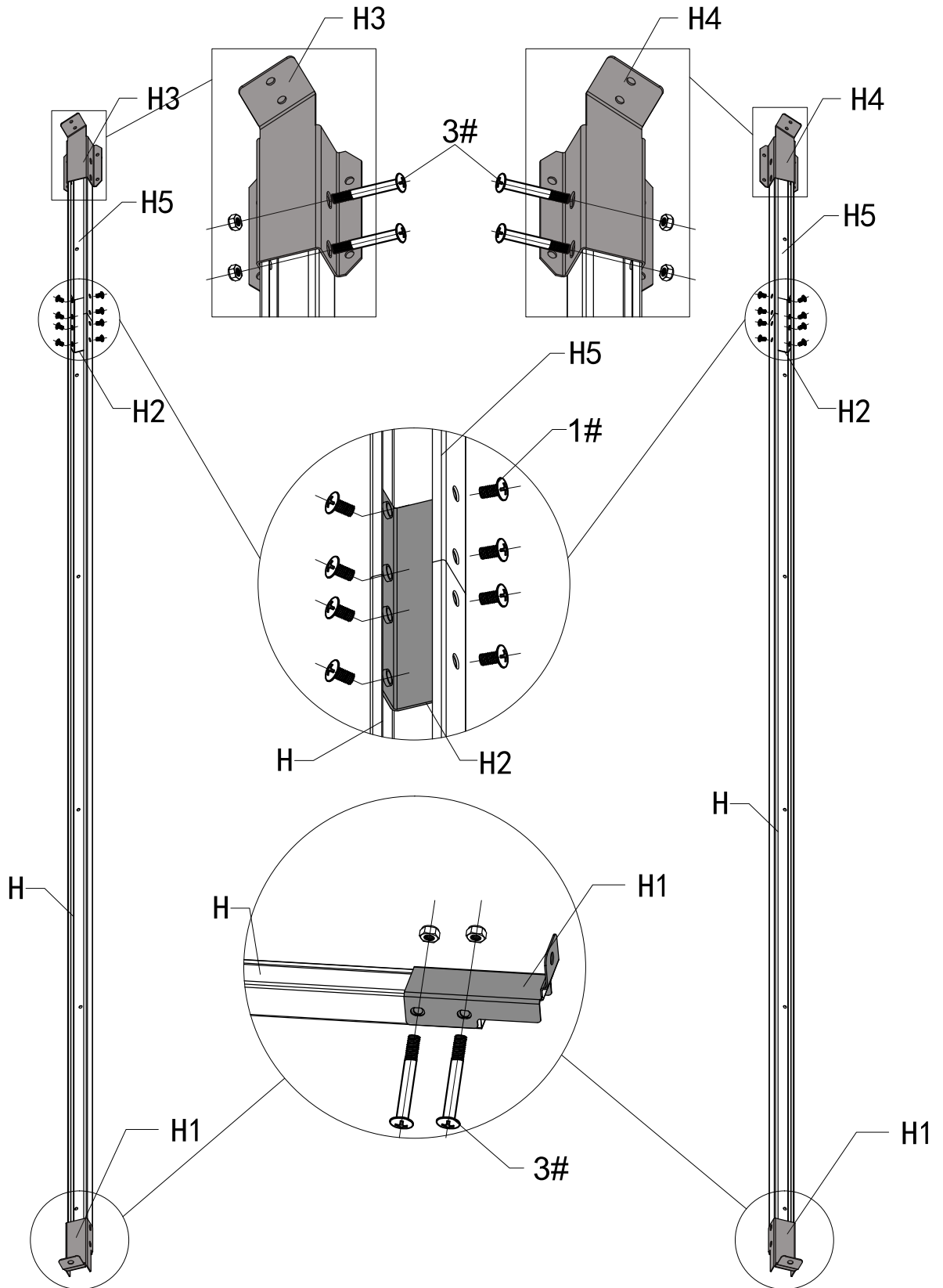
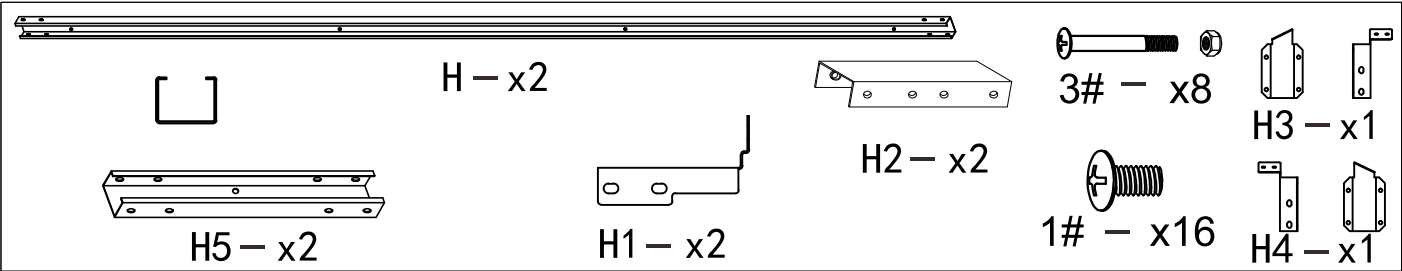

Front Supporting Pole Assembly



8# – x26

Use 6 screws #8 to Secure bracket #H3/#H4 to roof panels(2 screws)and wall panels(4 screws).
Use 2 screws #8 to Secure supporting pole #H5 to wall panels.

Use 5 screws #8 to Secure supporting pole #H to wall panels.

Repeat above process to assemble the other side.

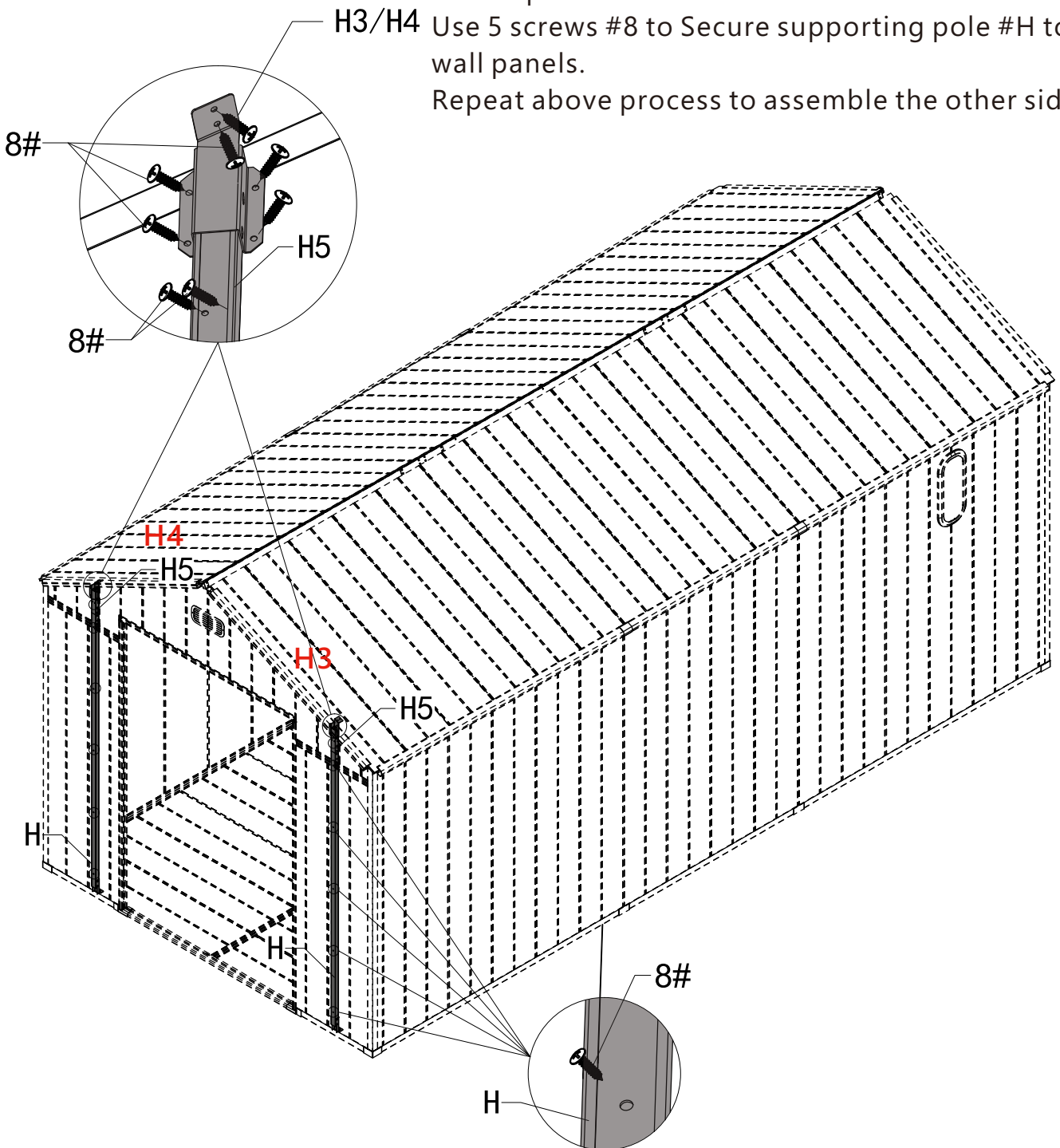

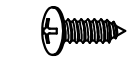

8# - x20

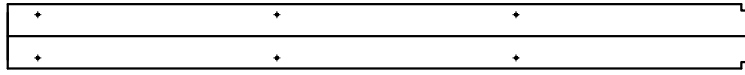

E1 - x2

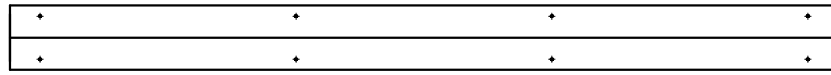

E2 - x1

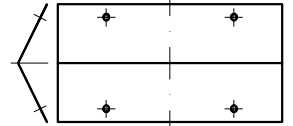

E - x2

Assemble the metal ridge cap

E/E1/E2

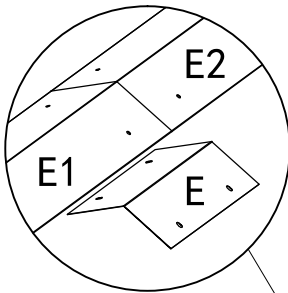
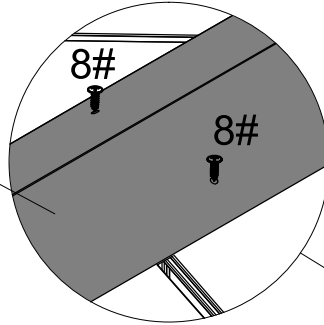

E is installed below E1/E2.

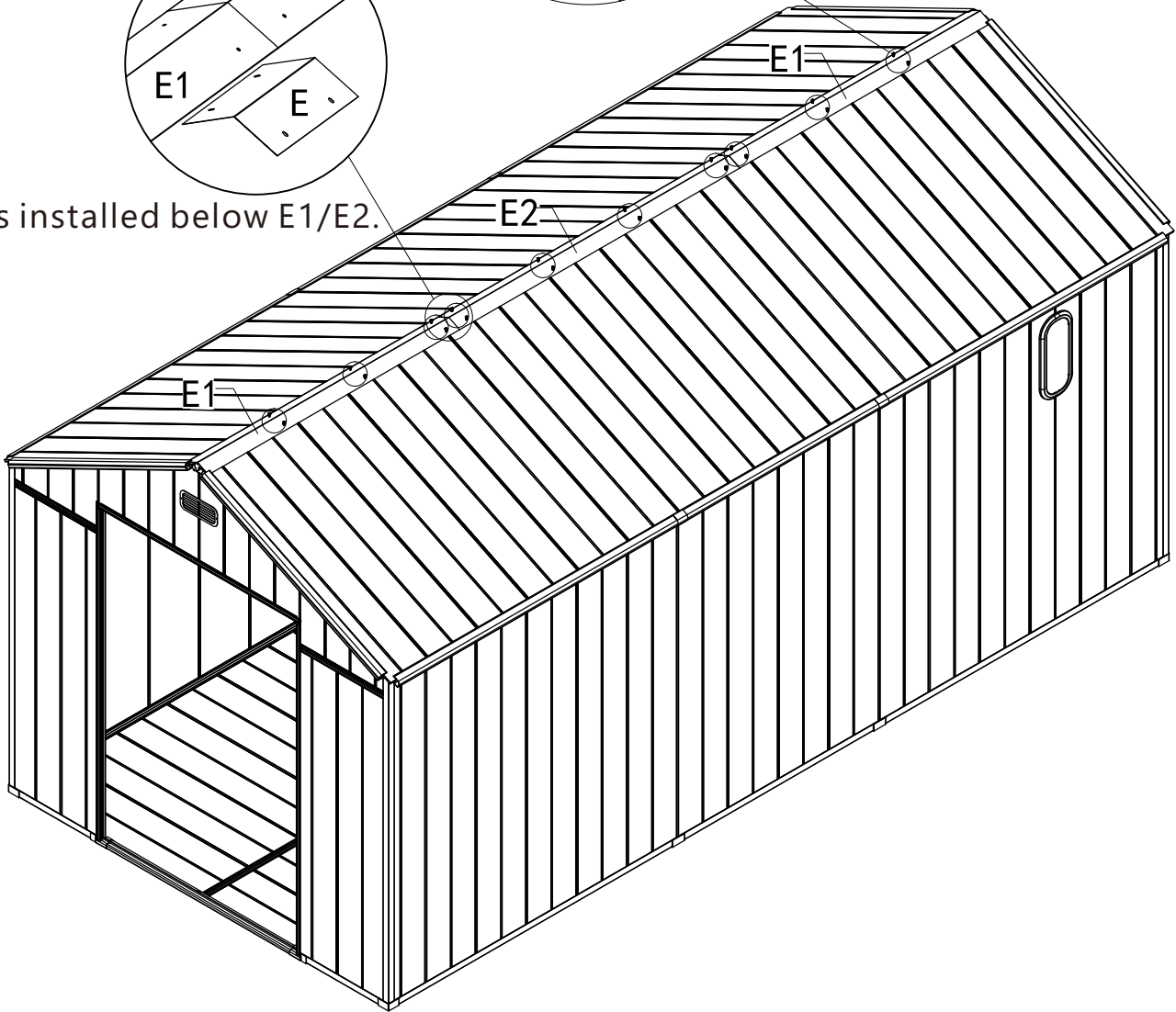

4x14
6# - x16

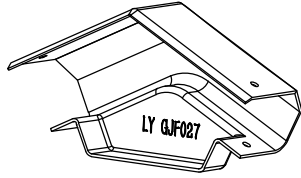

GJF027-x2

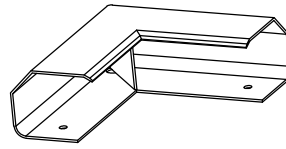

GJF024-x4

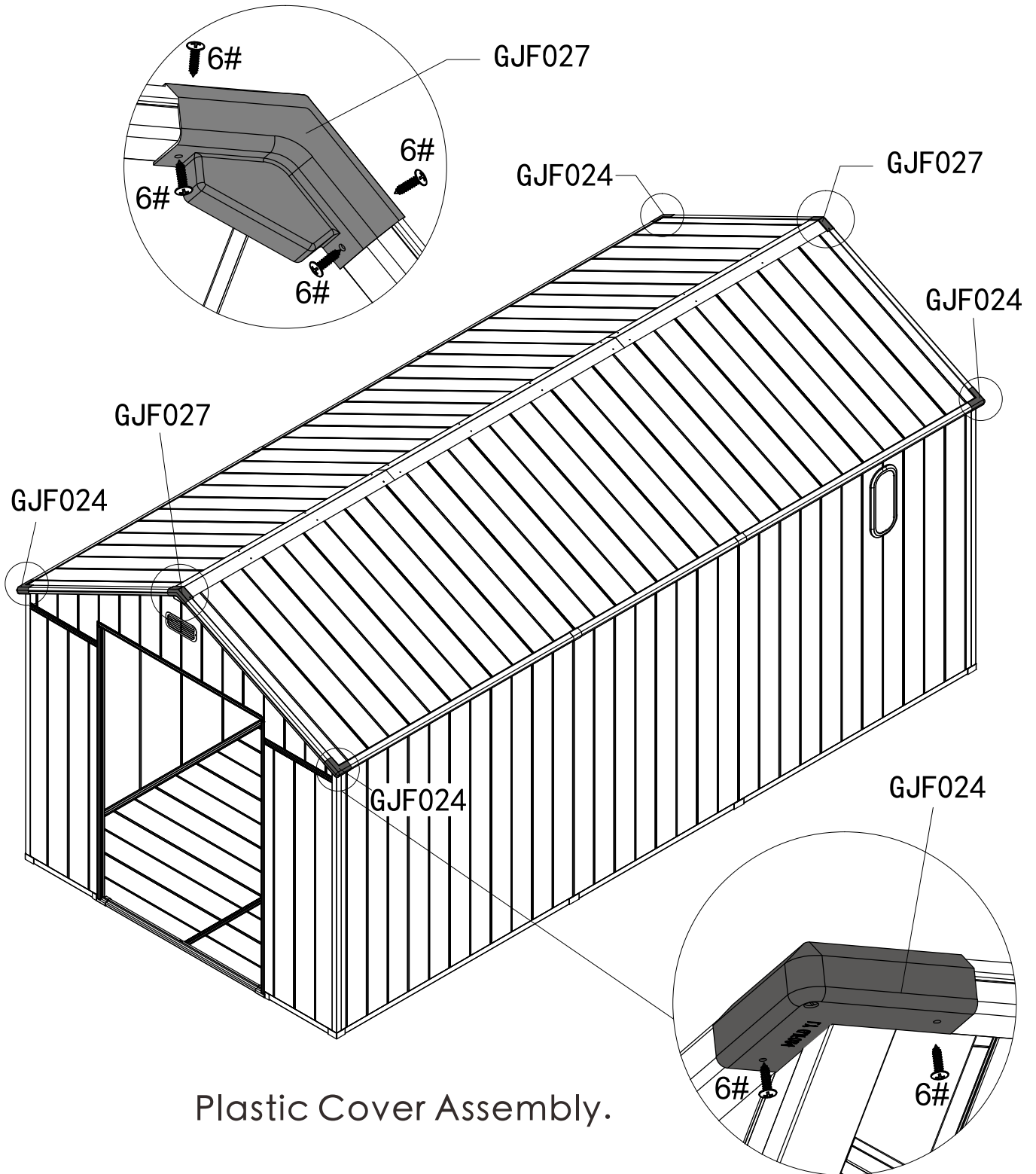

Plastic Cover Assembly.



4x14

6# - x16

Use 8 screws #6 to fix the roof panels and wall covers #E3/E4 as shown. Repeat the above steps to assemble another side.

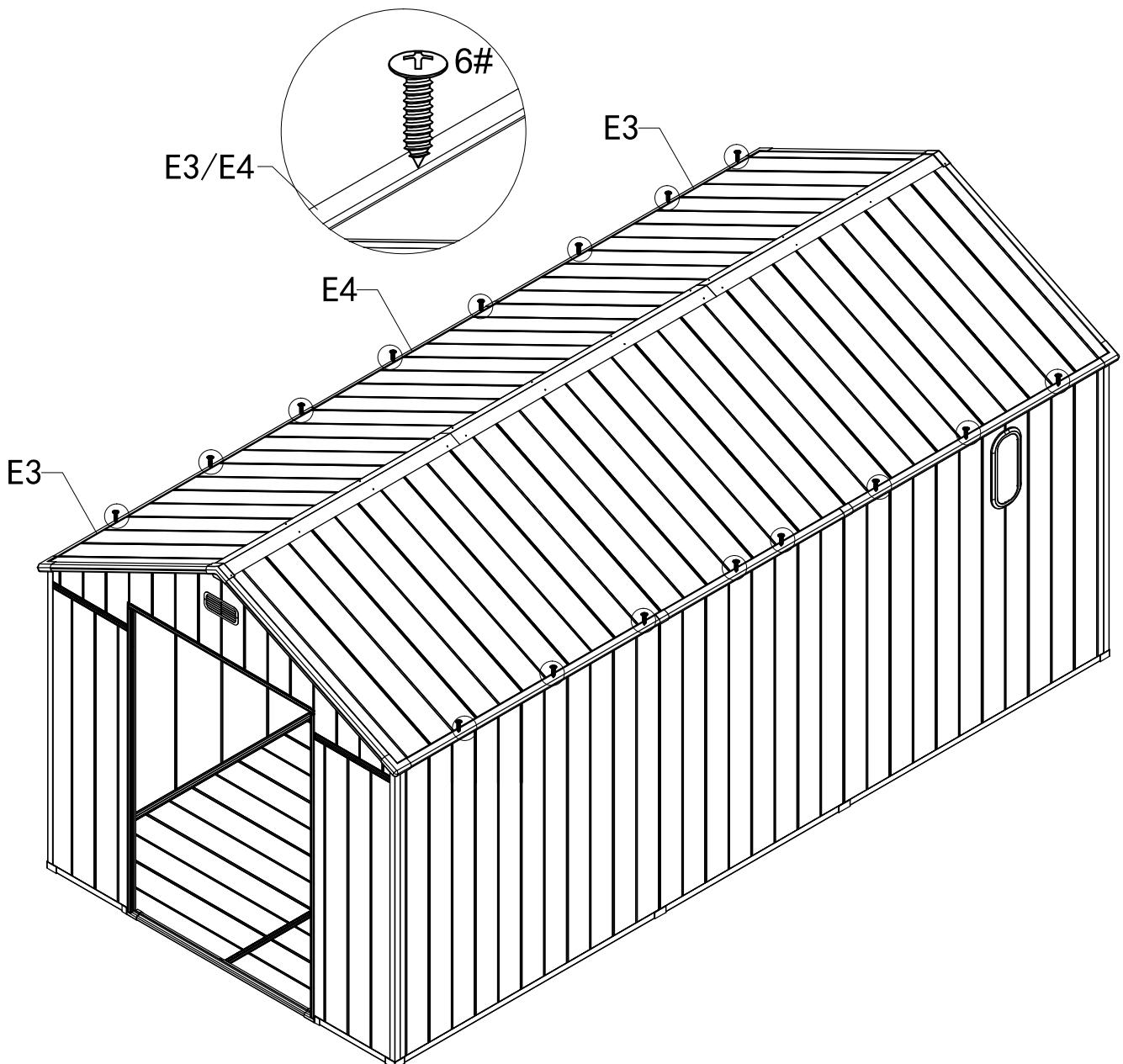

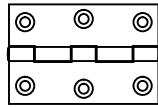

HY - x4



7# - x12

Assemble the hinges

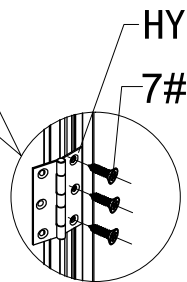
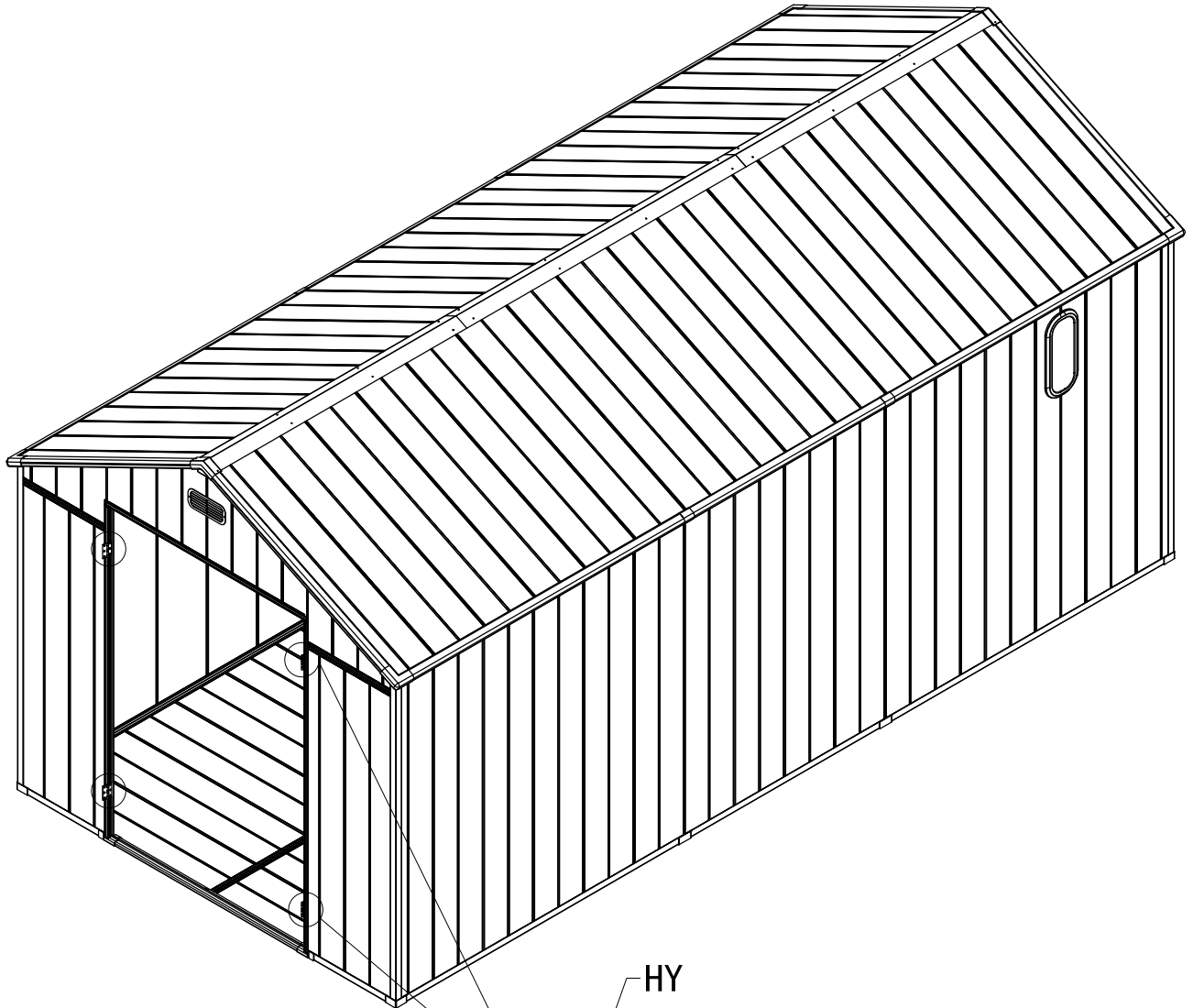

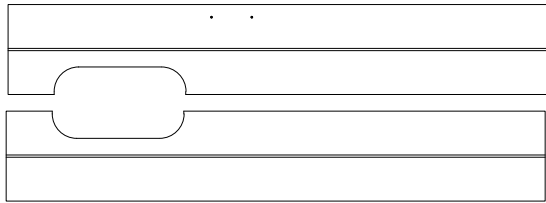

M2 - x1

M1 - x1



M5 - x1



M6 - x1

Assemble the left door

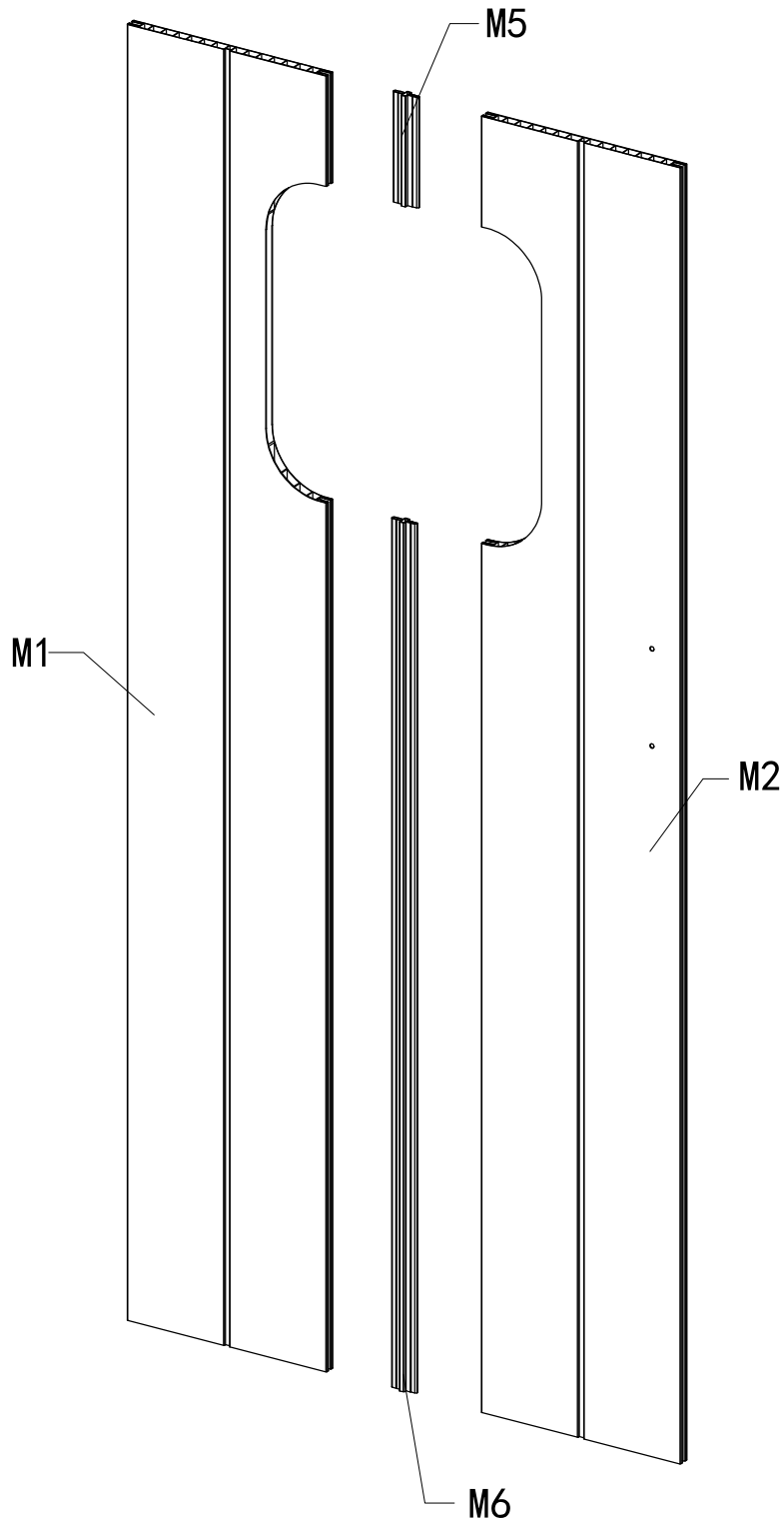

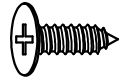

5# - x6

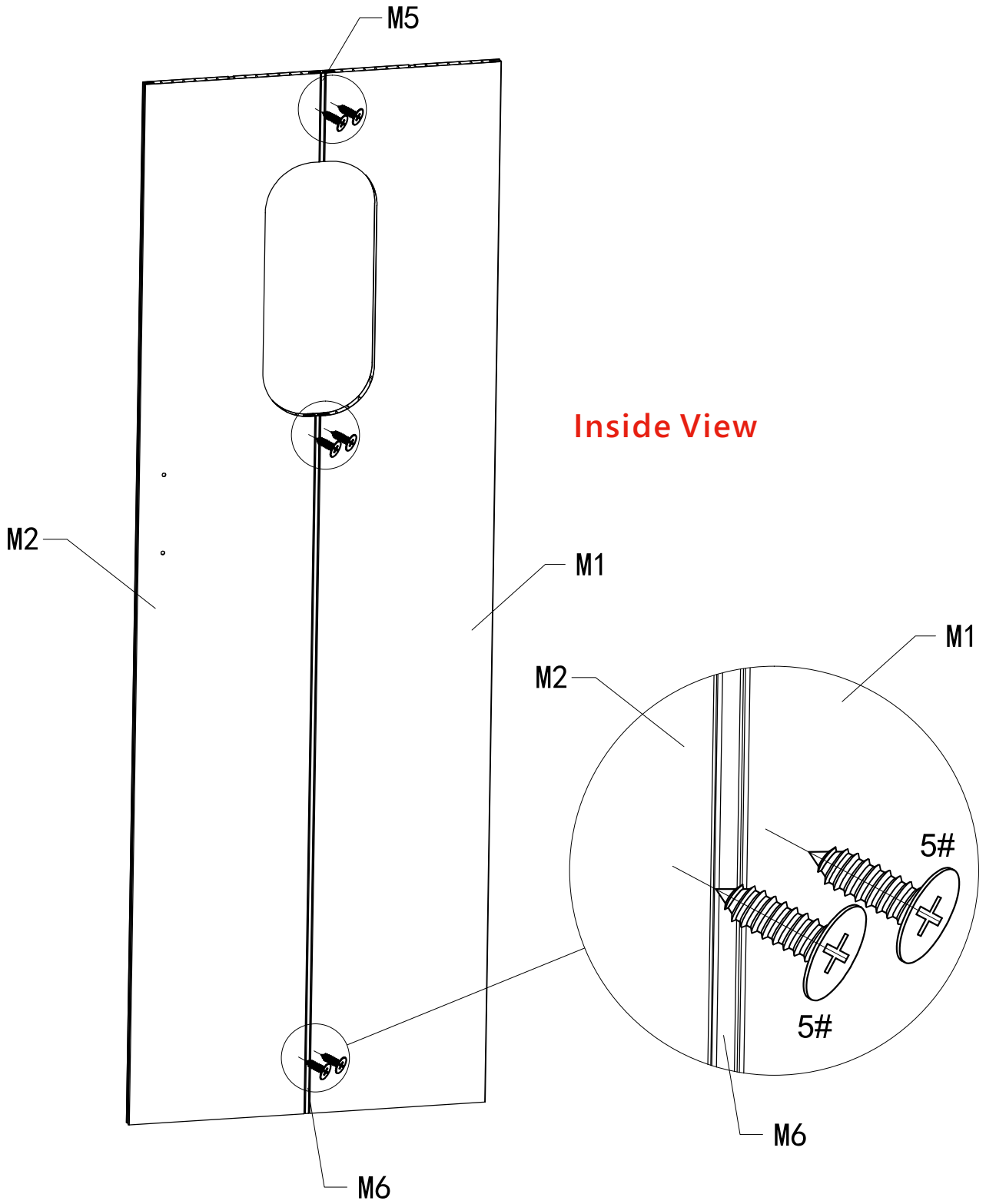

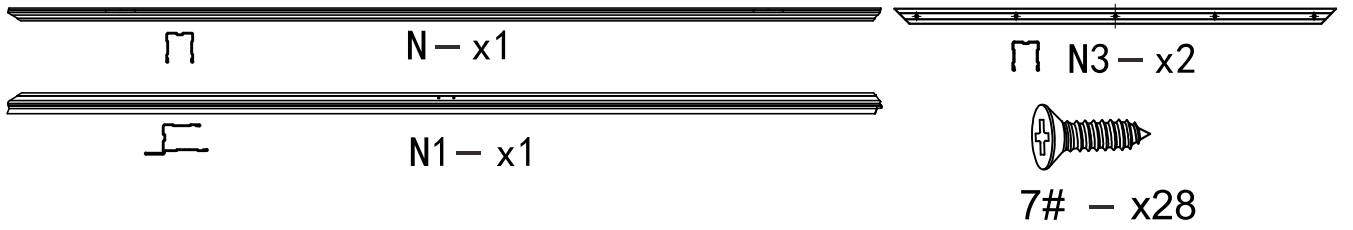

Assemble the door frame

Inside View

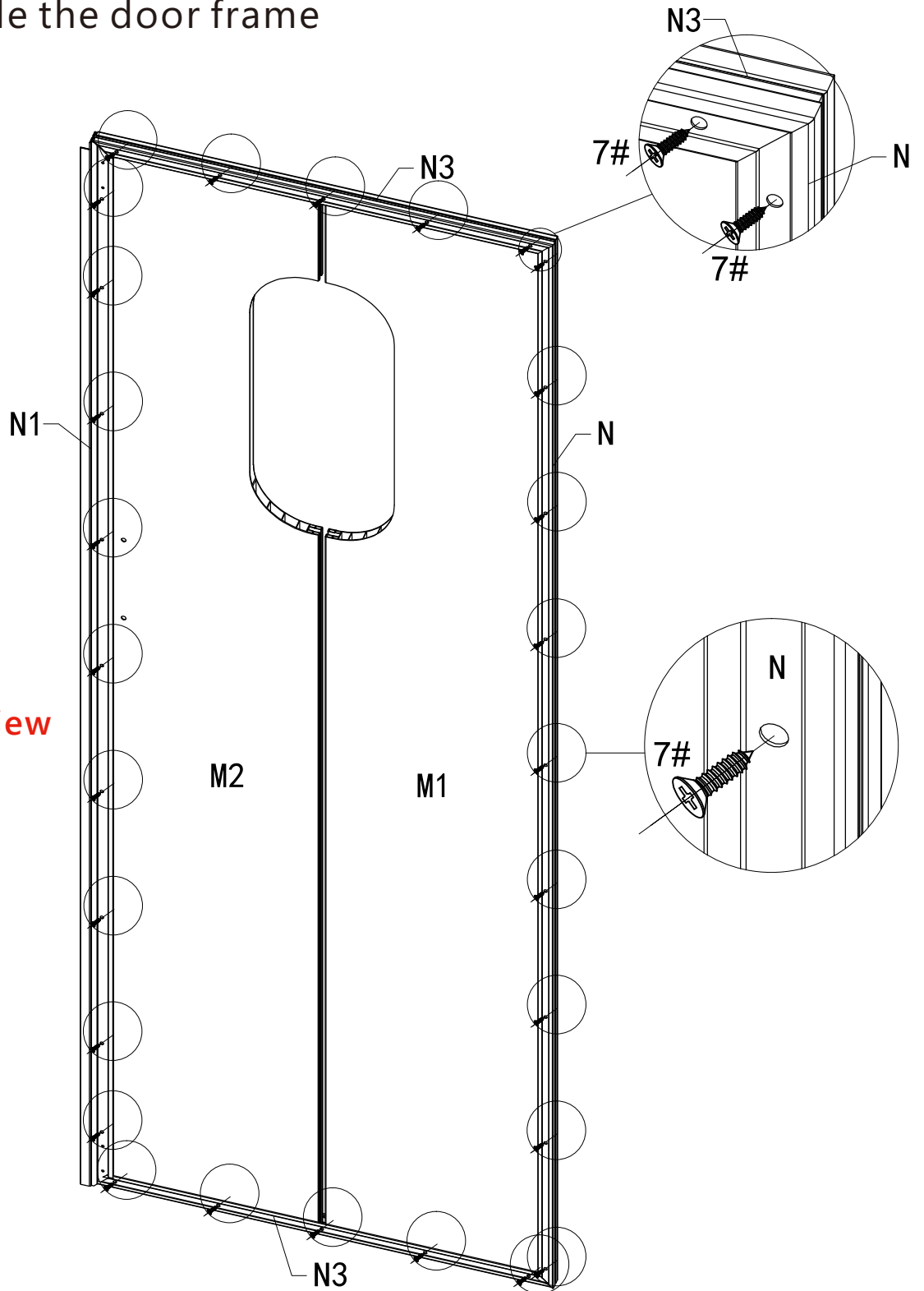

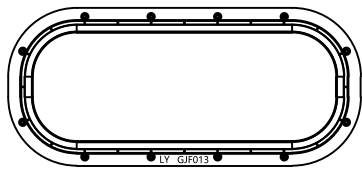

GJF013-x1

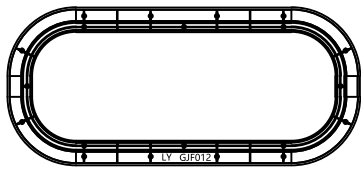

GJF012-x1

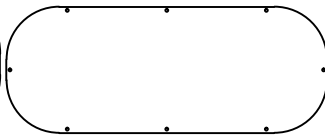

R-x1



9# - x8



10# - x12

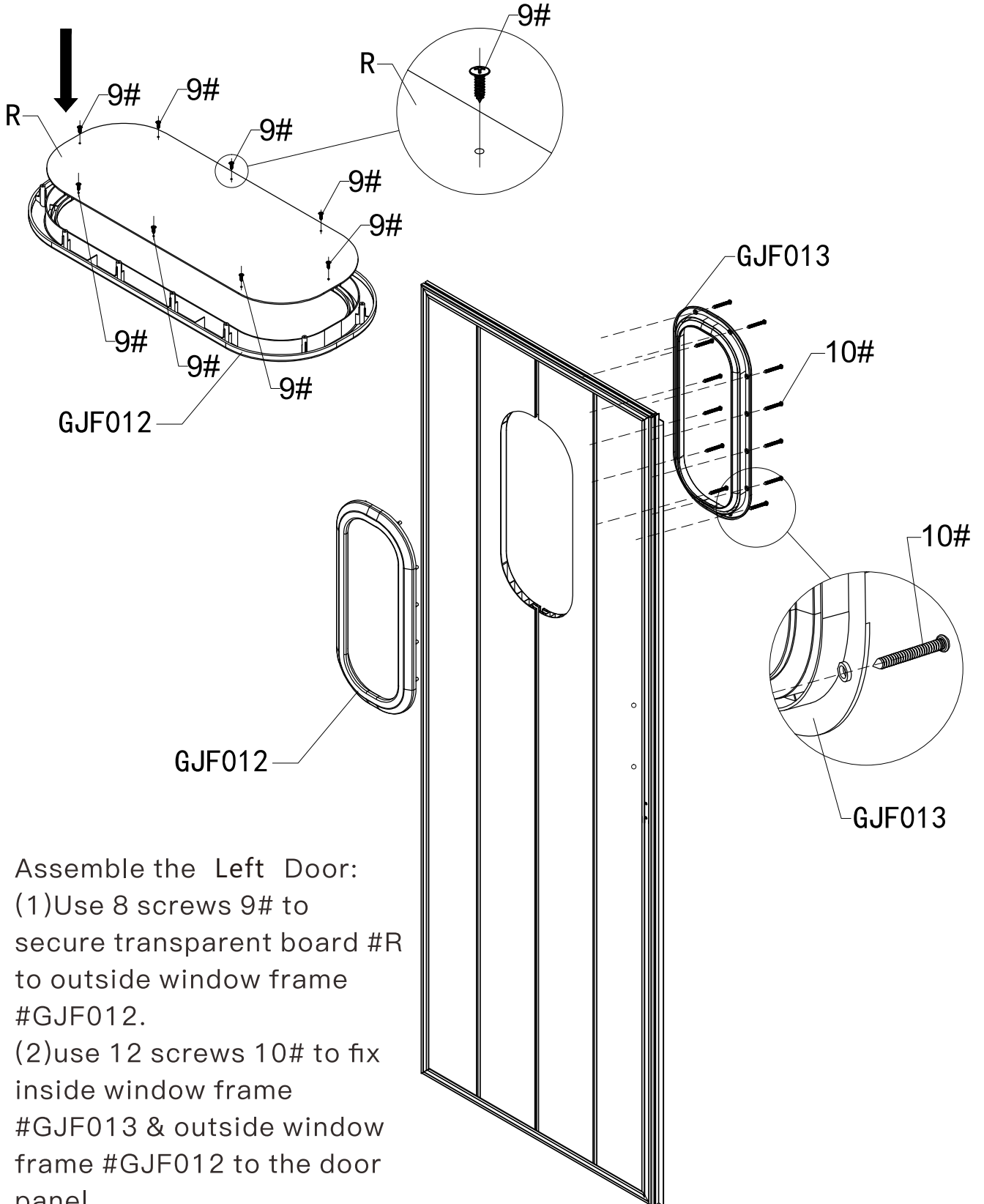

Assemble the Left Door:

- (1) Use 8 screws 9# to secure transparent board #R to outside window frame #GJF013.
- (2) Use 12 screws 10# to fix inside window frame #GJF012 & outside window frame #GJF013 to the door panel.



GJF016-x1

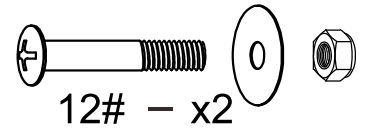

12# - x2

Doorknob Assembly

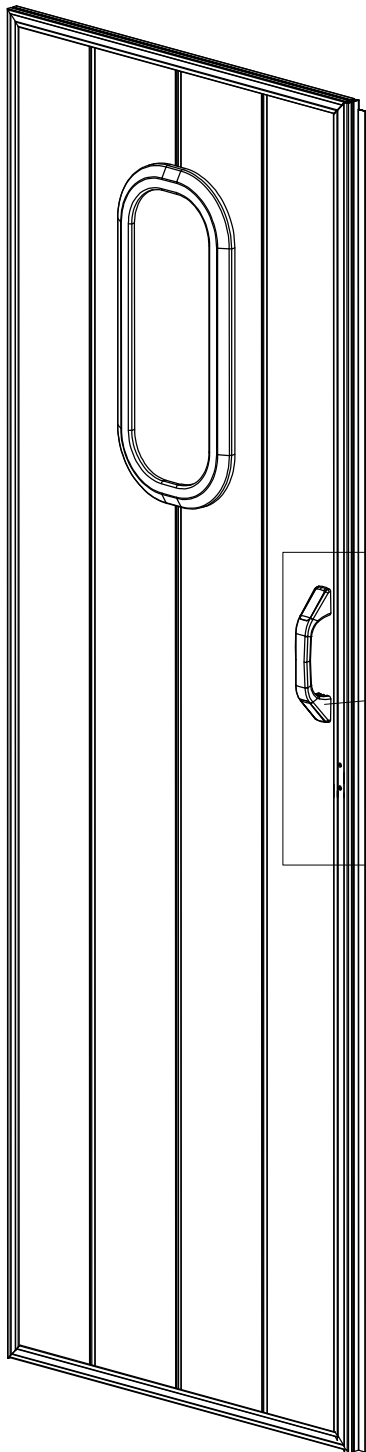

Outside View

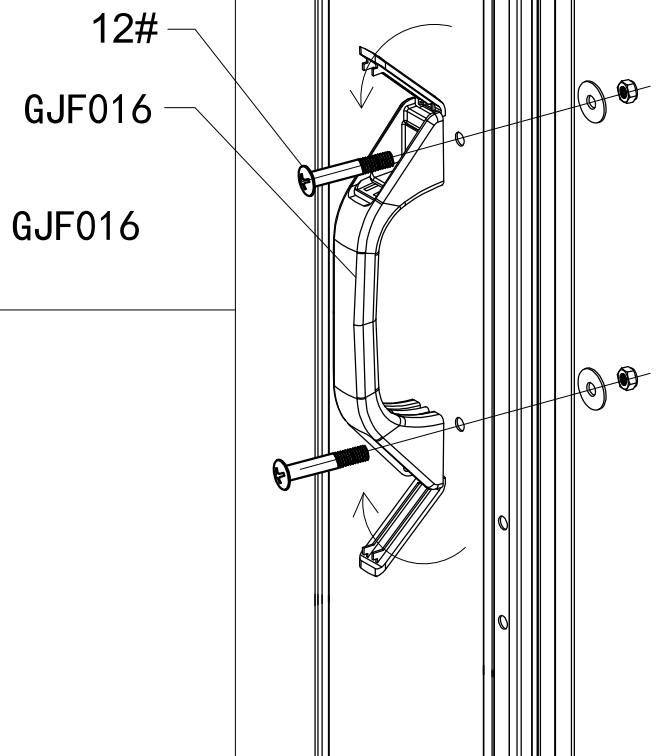

The doorknob has two covers, close the lid after fixing the screws.

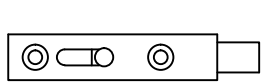

CX - x2



7# - x4



6# - x2

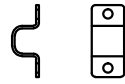

Q1 - x1

Install the top and bottom latches and #Q1.

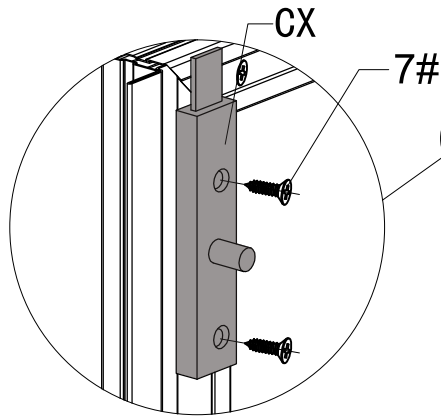

INSIDE VIEW

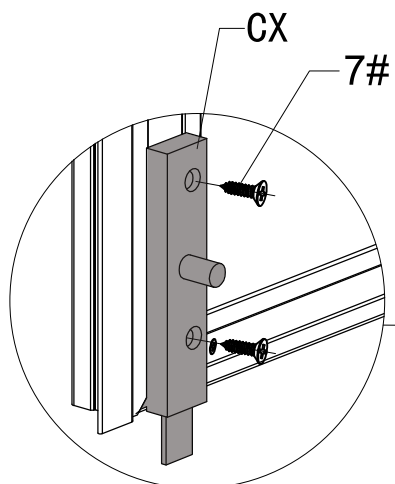
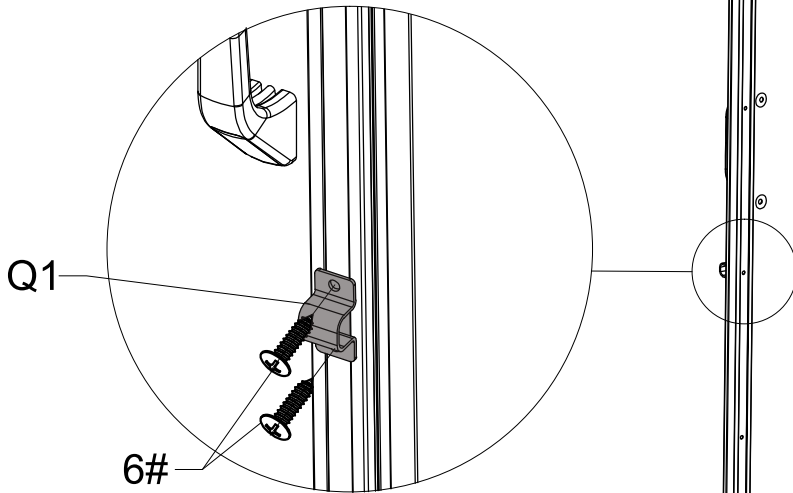

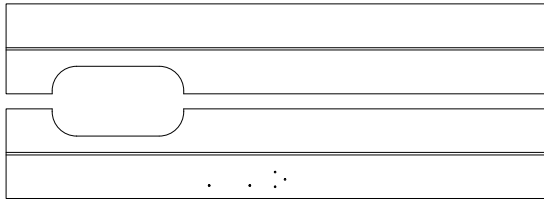

M4 - x1

M5 - x1

M3 - x1

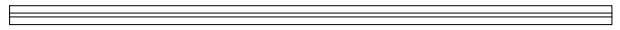

M6 - x1

Assemble the right door

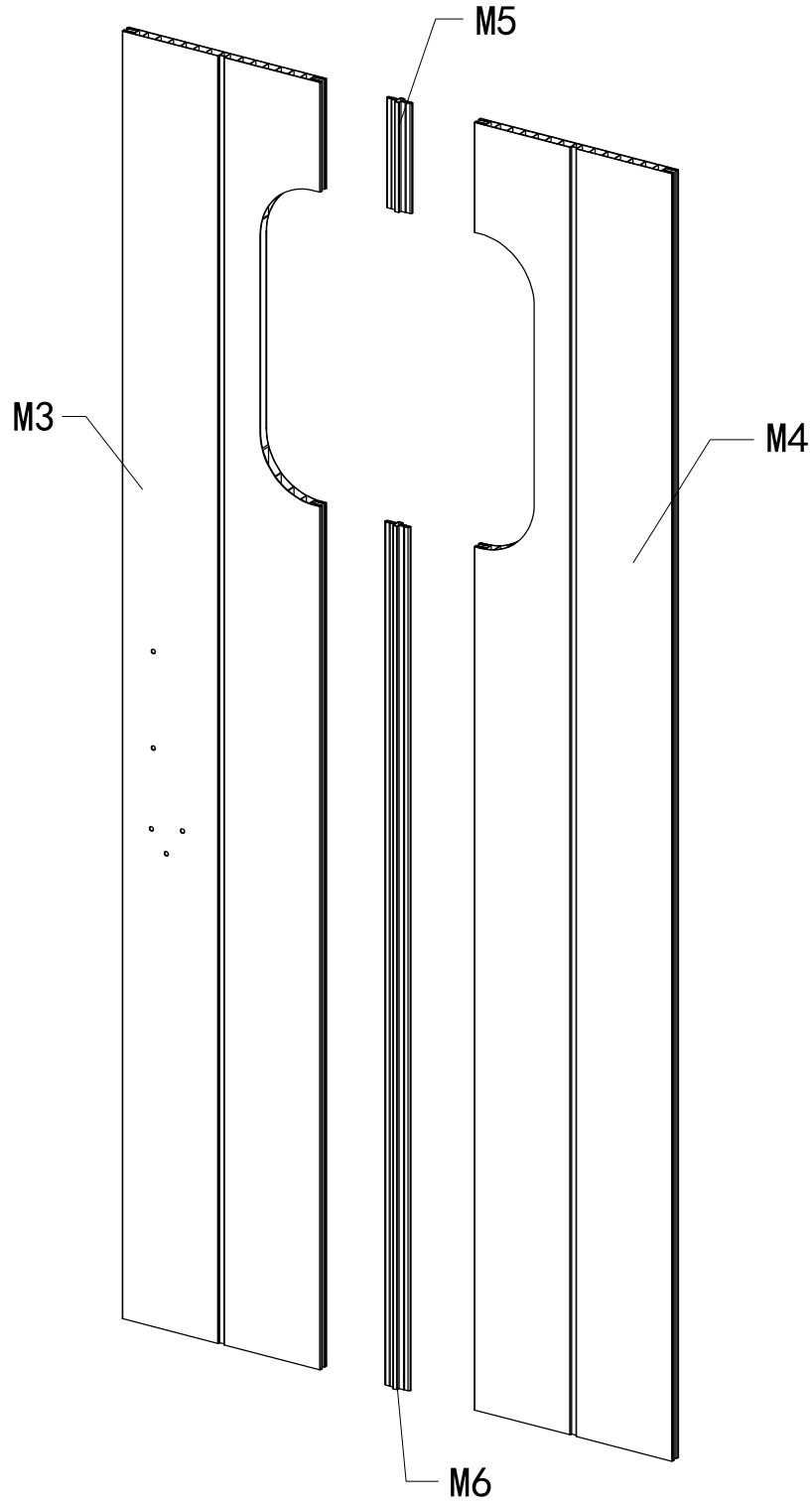

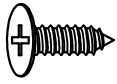

5# - x6

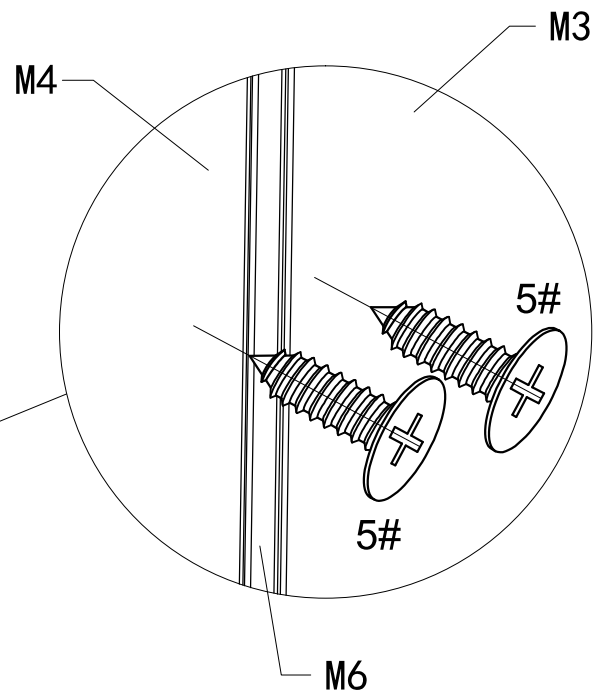
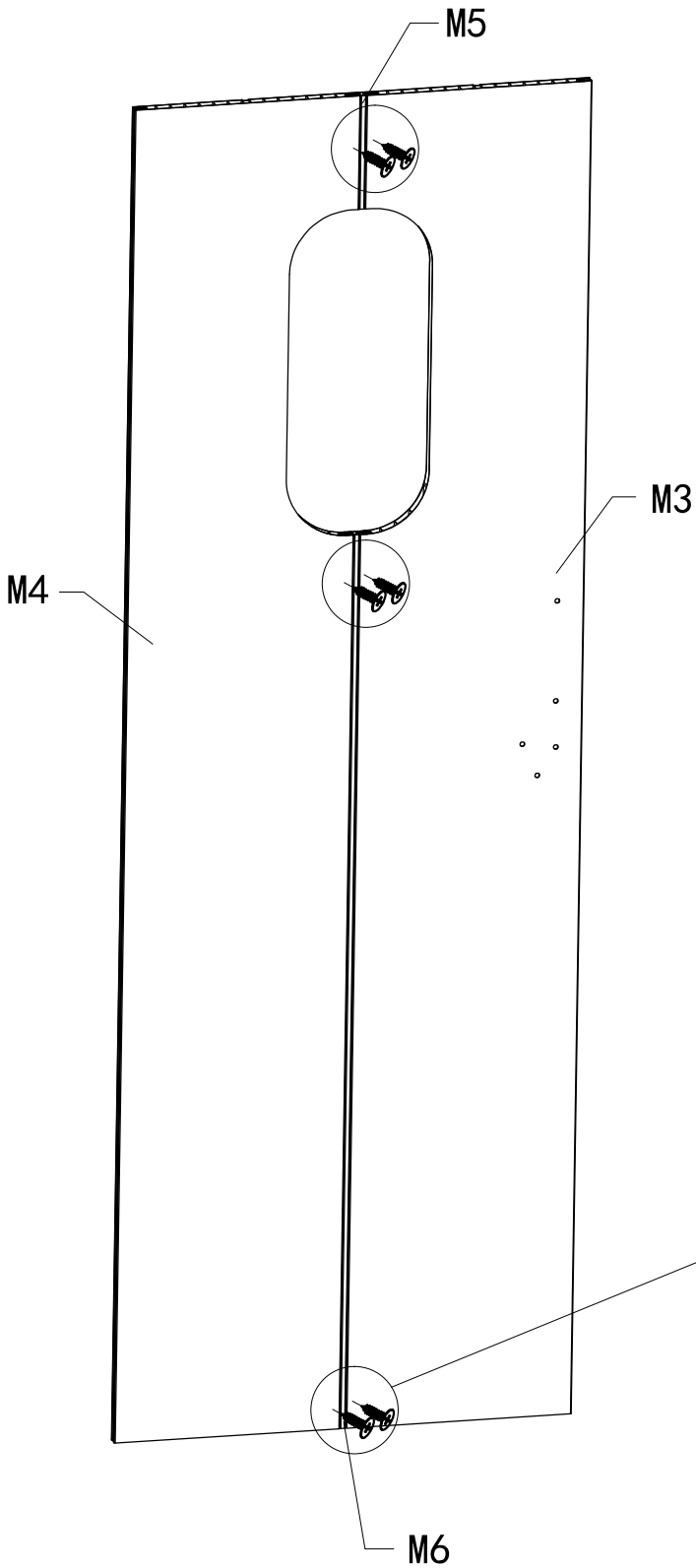

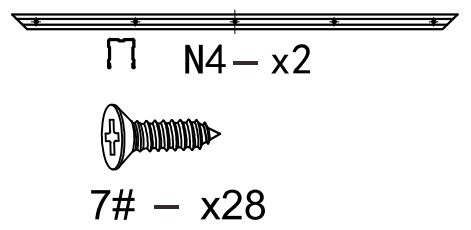
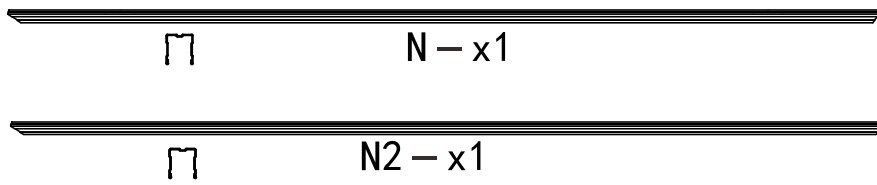

Assemble the door frame

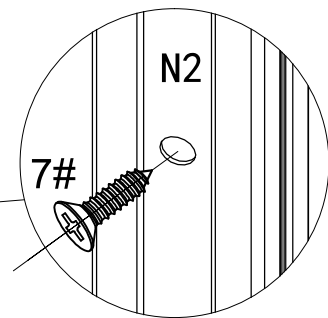
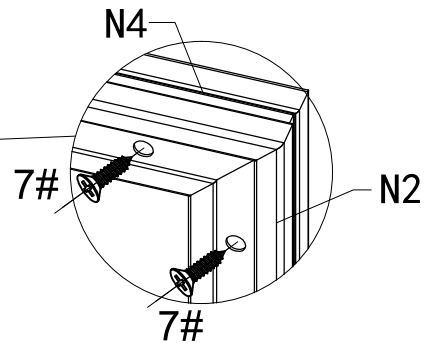
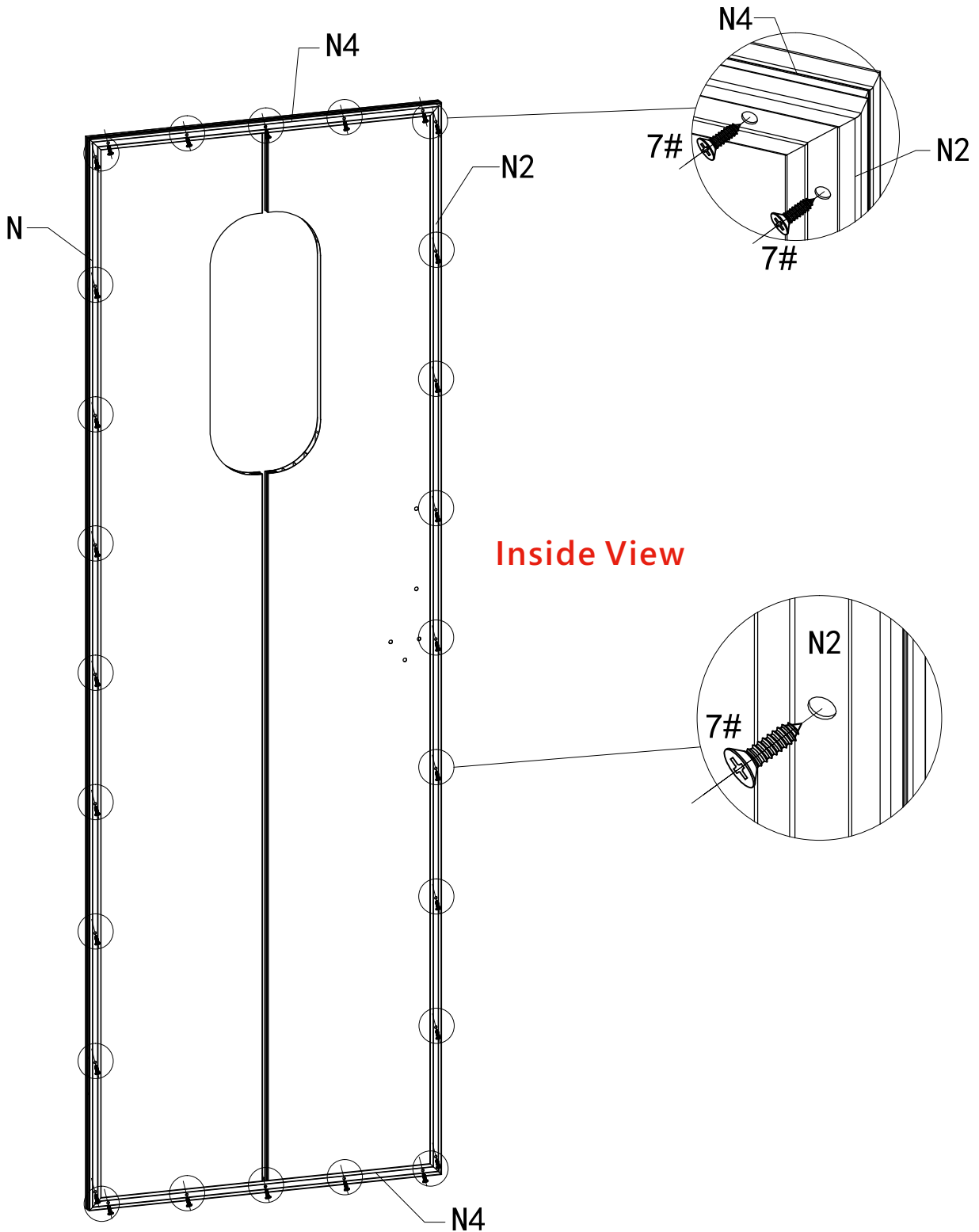

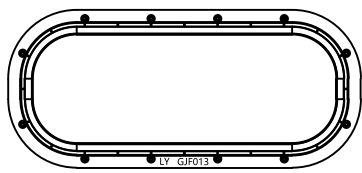

GJF013-x1

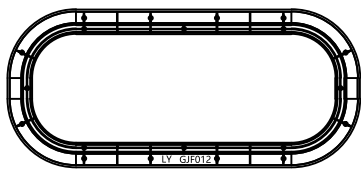

GJF012-x1

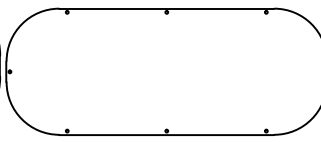

R-x1



9# - x8



10# - x12

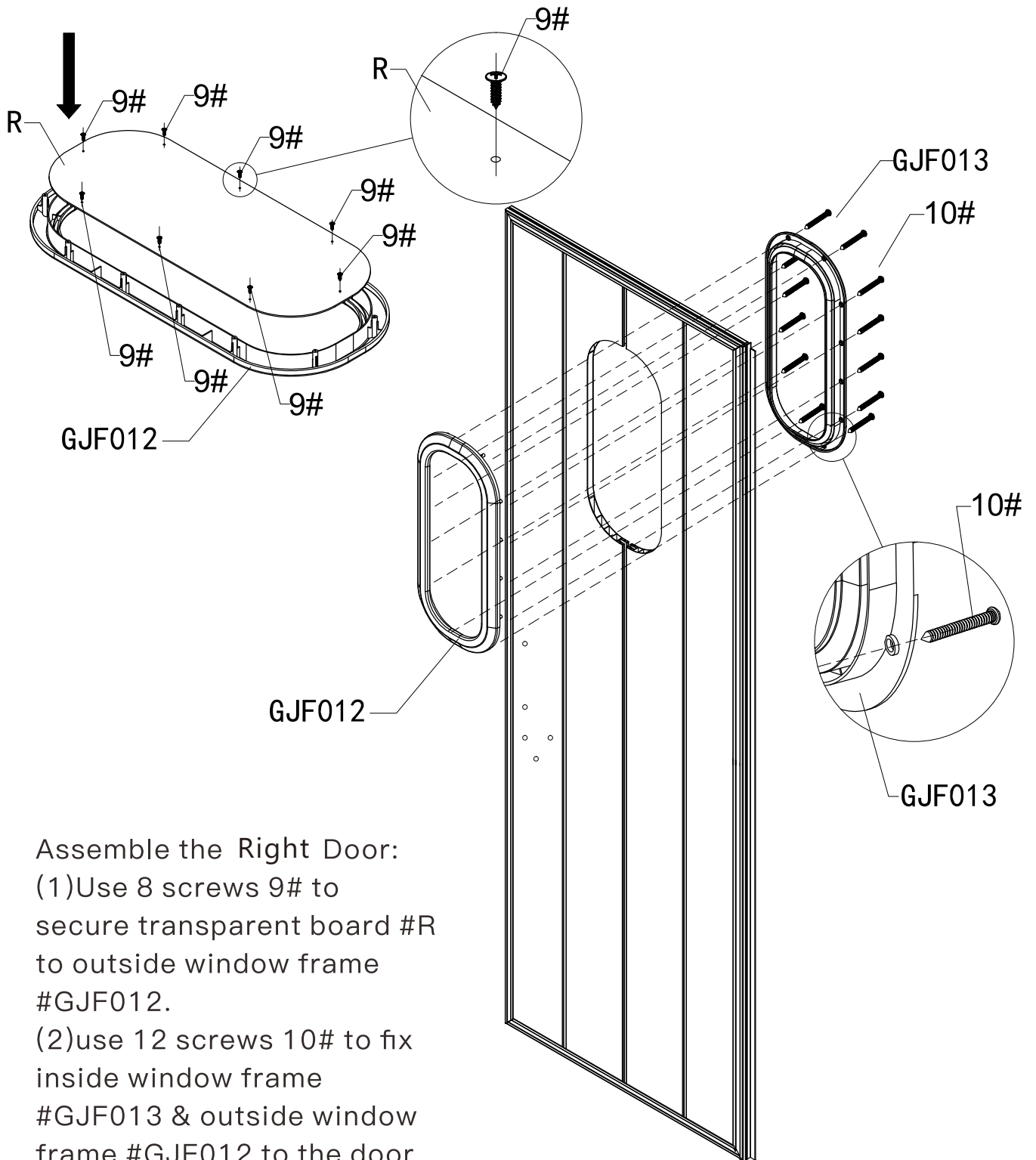

Assemble the Right Door:
 (1) Use 8 screws 9# to secure transparent board #R to outside window frame #GJF012.
 (2) Use 12 screws 10# to fix inside window frame #GJF013 & outside window frame #GJF012 to the door panel.

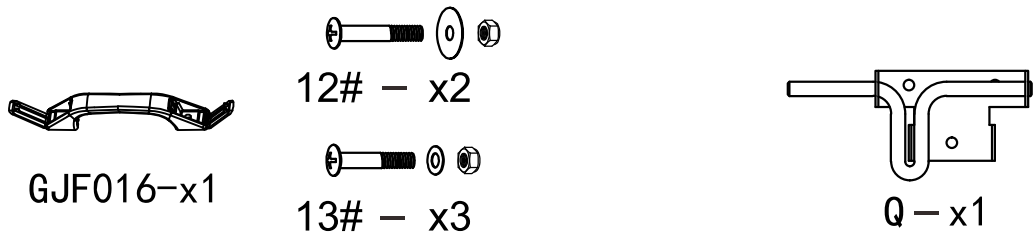

Doorknob and Locks Assembly

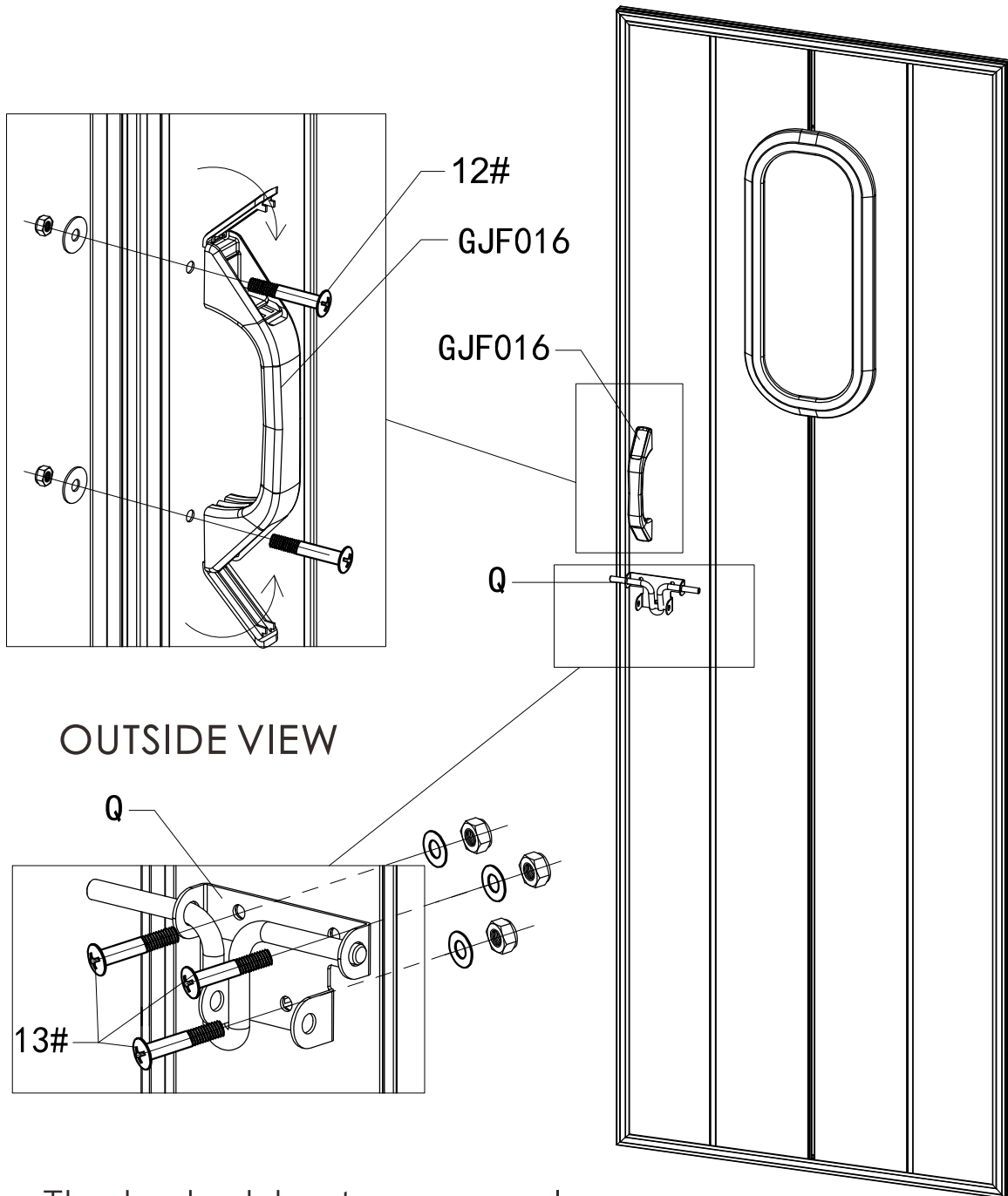

The doorknob has two covers, close the lid after fixing the screws.



7# - x12

Secure 2 doors and 4 hinges with 12 screws 7#.

7#

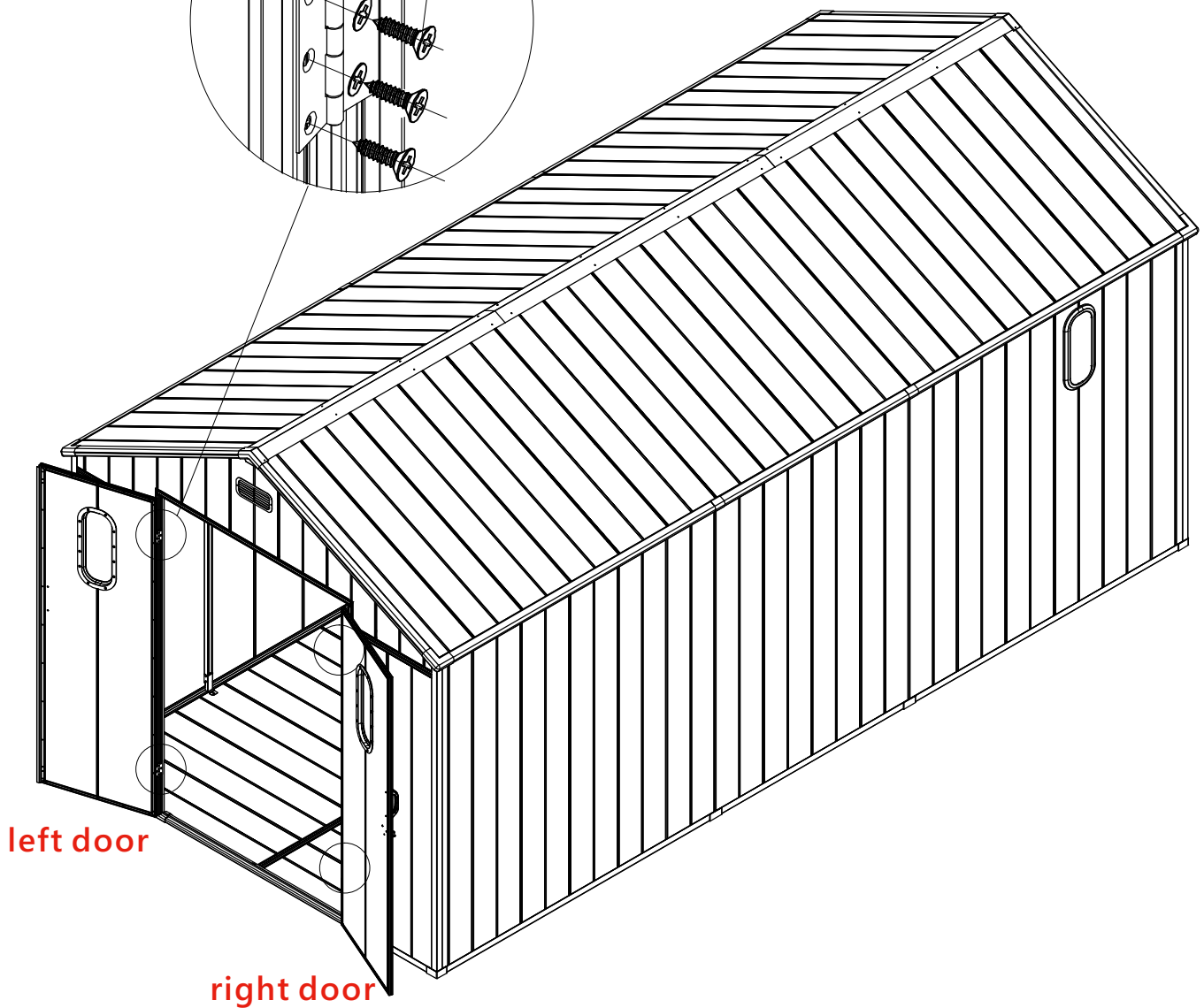
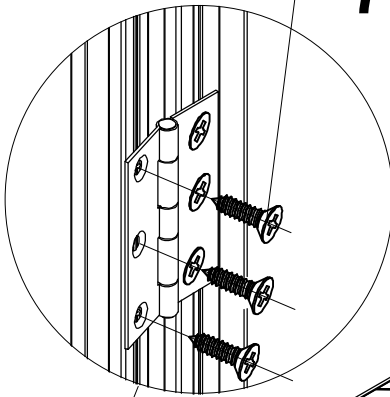

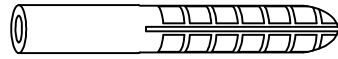

14# – x14

(Drill holes in the ground first)
Secure the chassis #H1 to the foundation
with 14 expansion screws #14 .

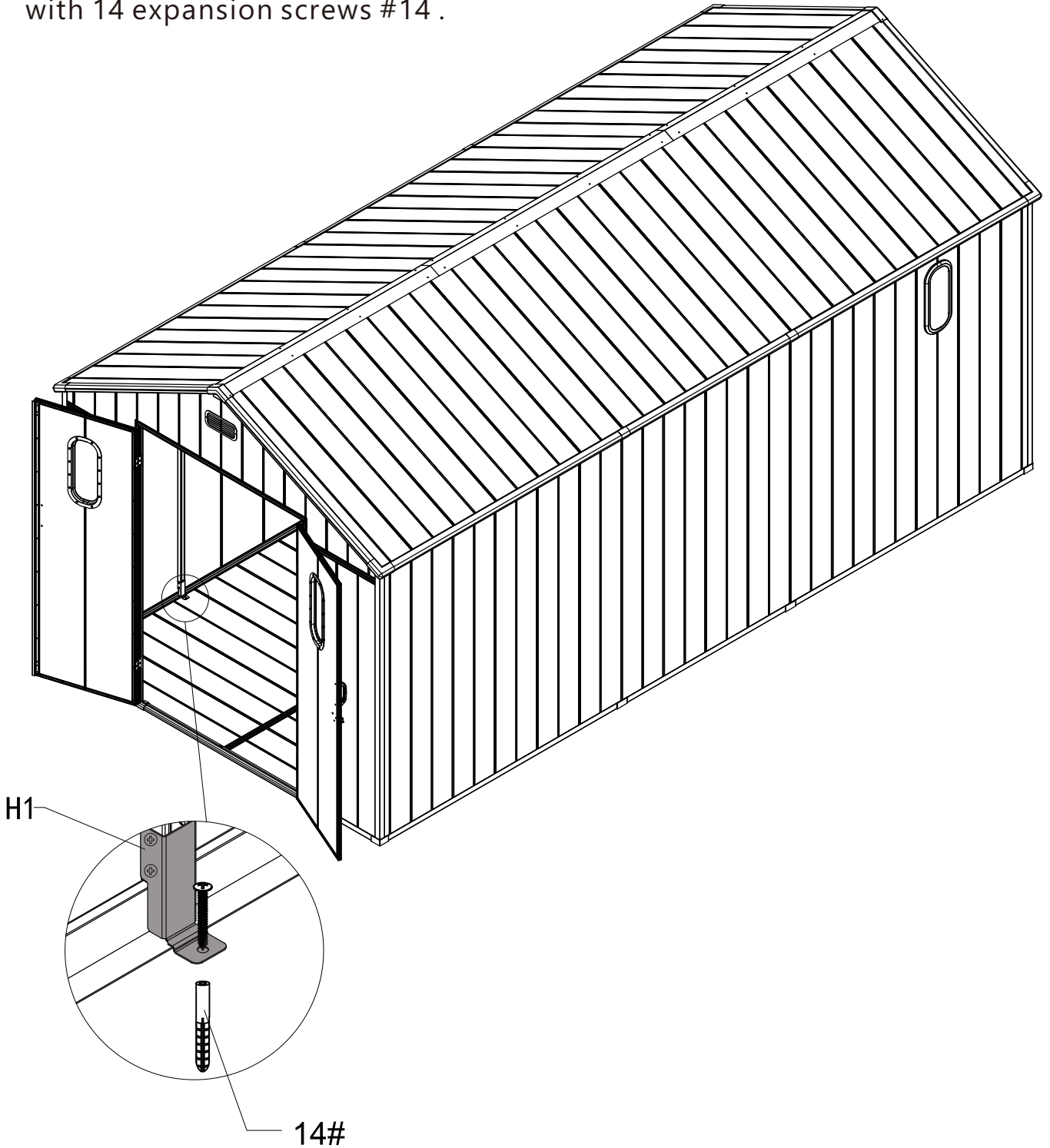



Thanks for your purchase.

At domi outdoor living, we believe in our products.

That's why we provide a 12-month warranty and friendly, easy-to-reach after-sales service. So, if you have any questions about our product or assembly, please feel free to contact us. We are here for you.

Support:  

After-sales contact email:

service@domioutdoorliving.com

Please have your order ID available if you reach out for support.

If you have damaged parts or product, please send us photos for an immediate response.