

ASSEMBLY INSTRUCTIONS

DGWD-V1

FTLFST-6033
FTLFST-6034

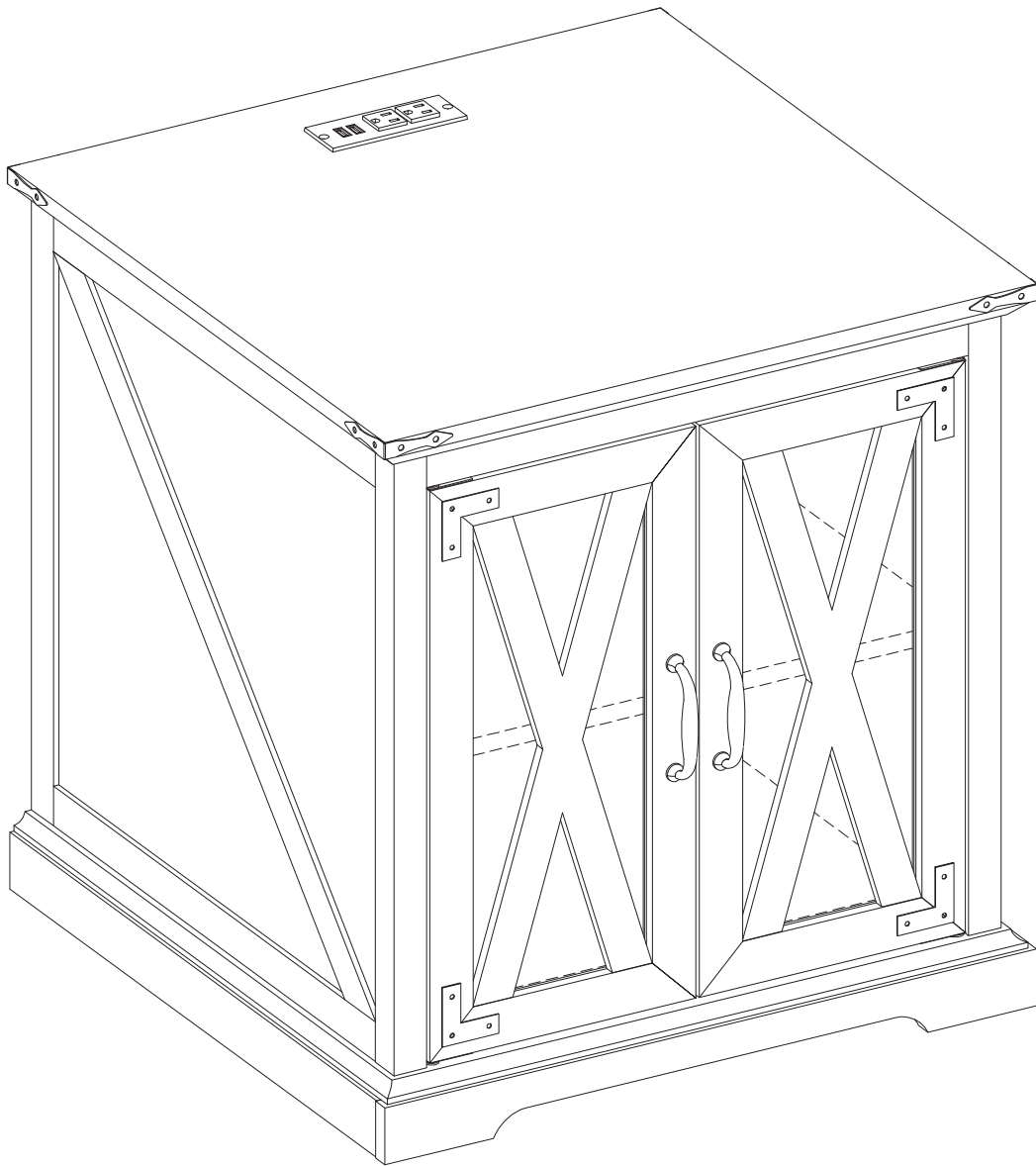

SIDETABLE

Notice:

1. Follow the installation instructions. Please confirm all accessories are preset before installation.
2. Do not fully tighten the screws during initial assembly. Fully tighten screws only once all pieces which are correctly assembled.
3. If you encounter any problems during installation, please contact our customer service.

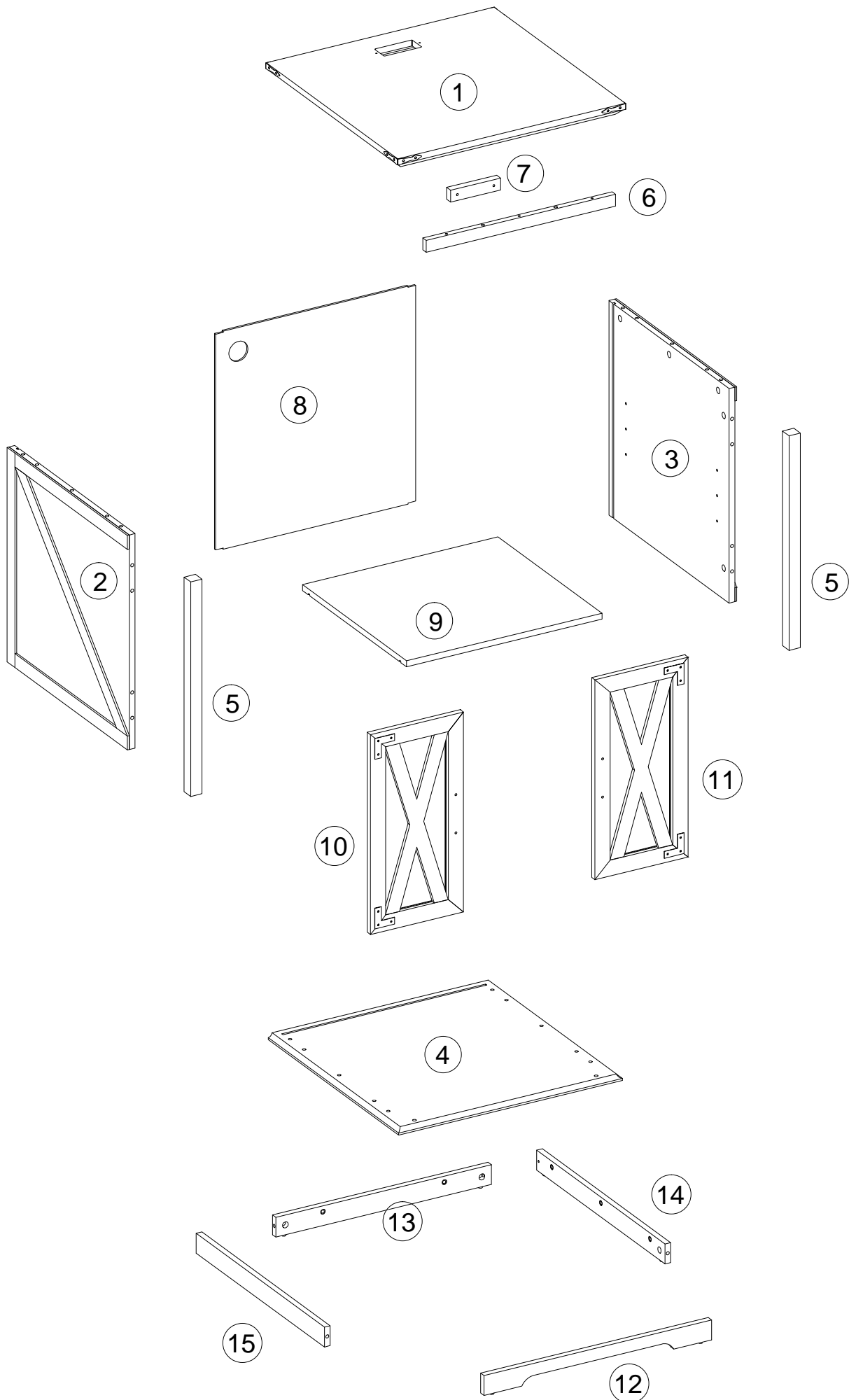

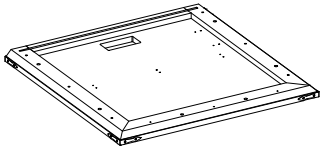

① x1

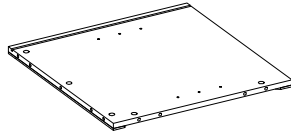

② x1

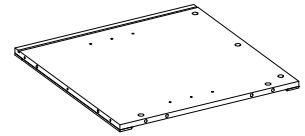

③ x1

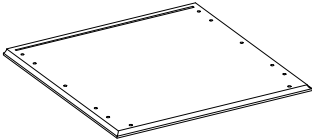

④ x1

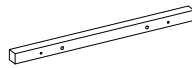

⑤ x2



⑥ x1



⑦ x1

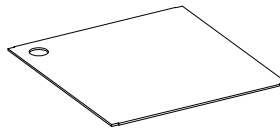

⑧ x1

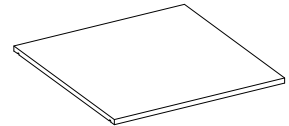

⑨ x1



⑩ x1



⑪ x1

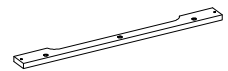

⑫ x1





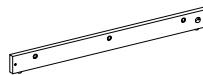

⑬ x1

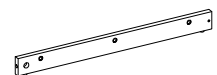



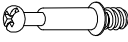

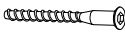

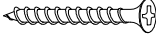

⑭ x1









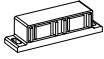



⑮ x1

A	x14	B	x14	C	x14	D	x6	E	x14
									
Ø6x35mm		Ø15x11mm		Ø8x30mm		Ø6.7x48mm		Ø30mm	

F	x3	G	x2	H	x1	I	x22	J	x11
									
Ø4x38mm		Ø4x25mm		M4x57mm		M6x12mm		25x25mm	

K	x4	L	x2	M	x2	N	x2	O	x1
									
Ø12x8mm		40x15.5mm		40x15.5mm		30x22mm			

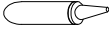
P	x2	Q	x20	R	x5	S	x4	T	x4
									
Ø3x15mm		Ø3x12mm				Ø5x16mm			

U	x4	V	x4	W	x2	X	x1	Y	x1
									
Ø3x17mm		Ø5/32x22mm				10g			

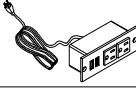
Z	x2	AA	x1
			
Ø3.5x12mm			

1

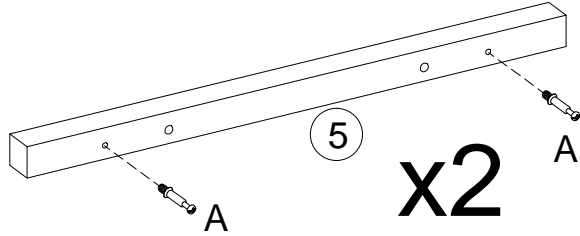
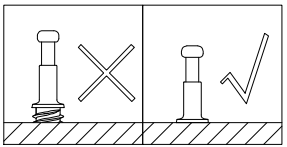
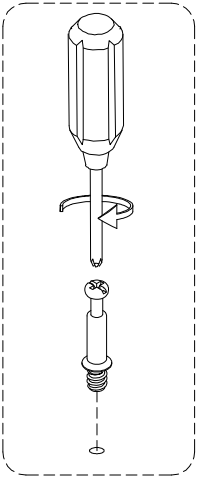
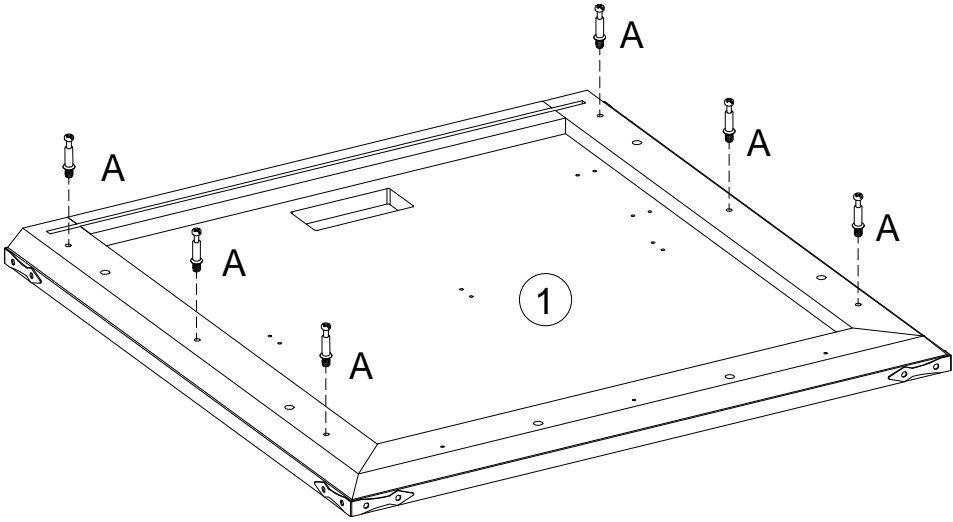
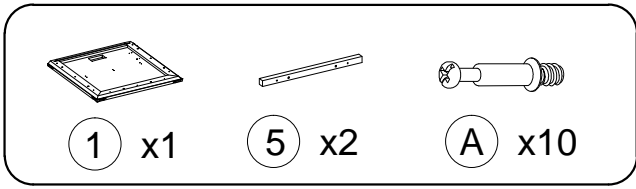

2

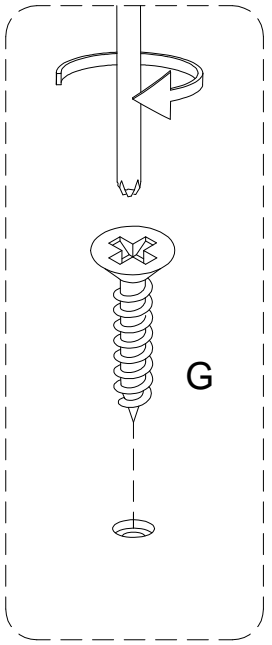
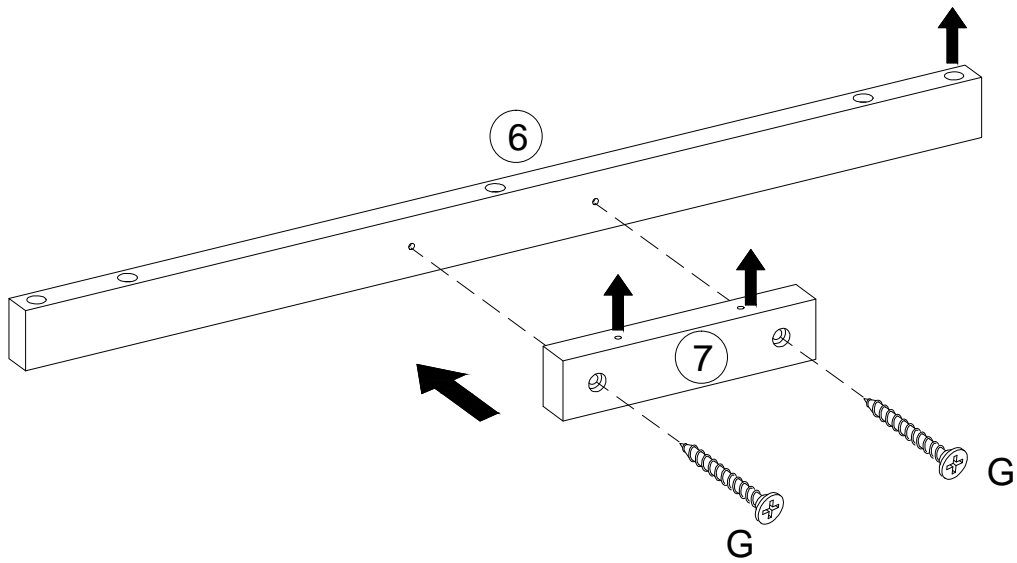
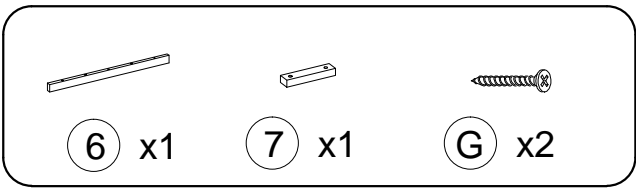

Pay attention to the orientation of the hole.

3

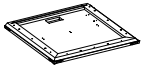

1 x1



6 x1



C x2

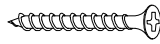

F x3

Pay attention to the orientation of the hole.

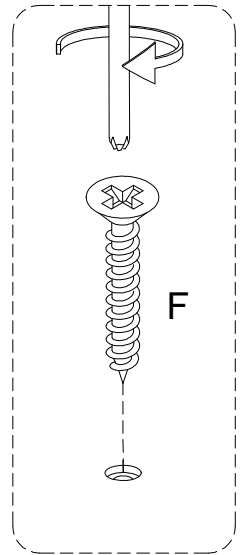
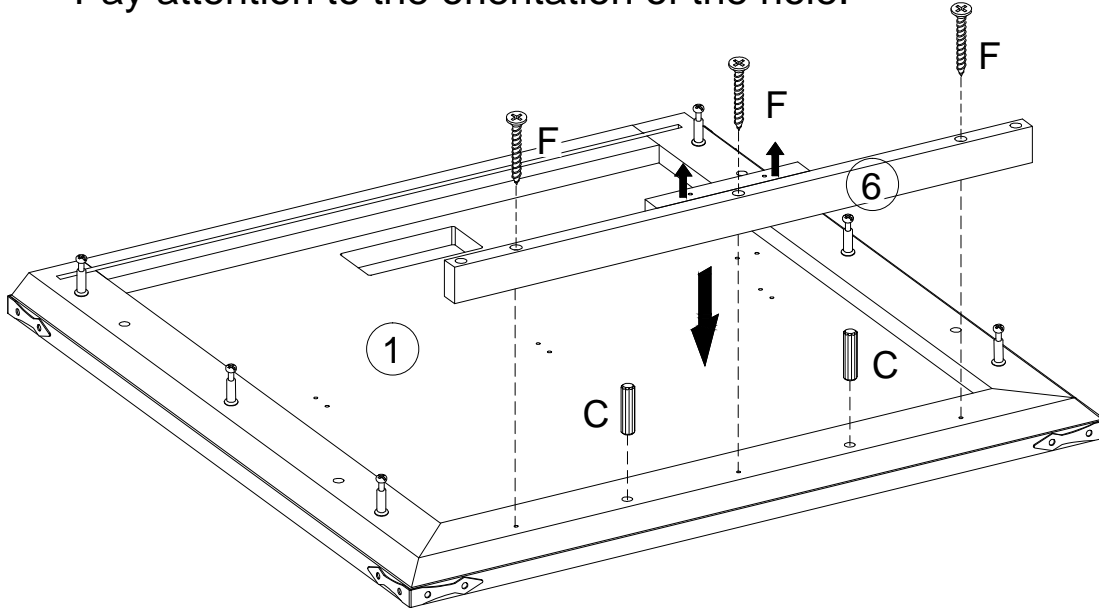

4

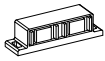

O x1



P x2

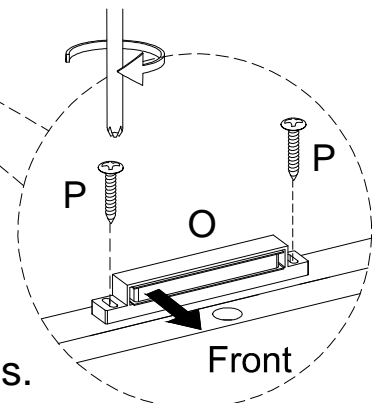
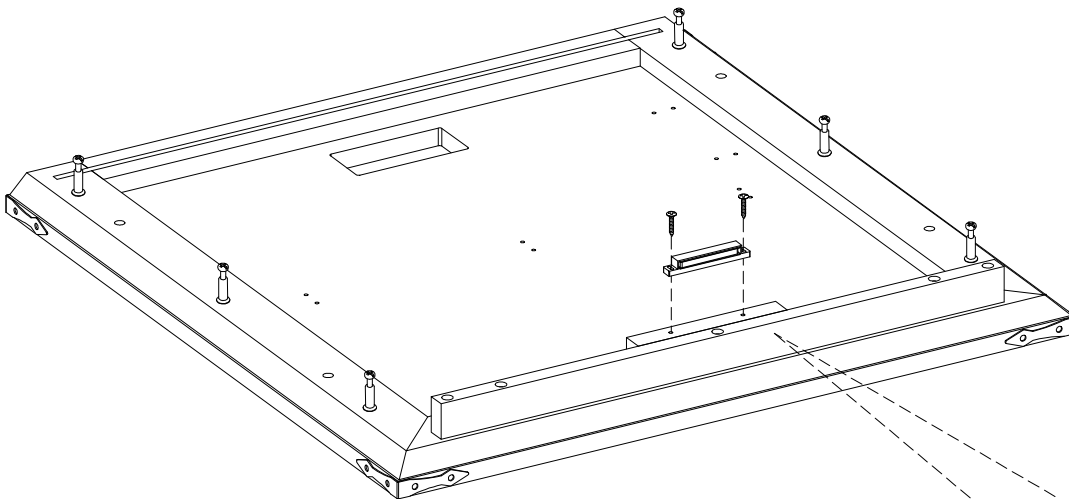

Magnetic catch should face outwards.

5

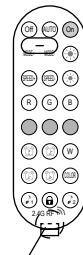
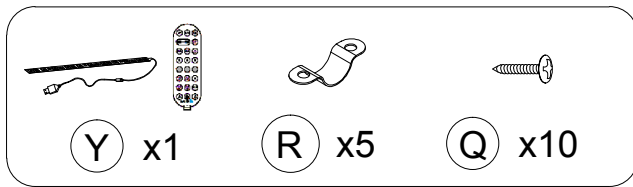

Tear off the tape and apply it to the bottom plate, then press it firmly with your hand.

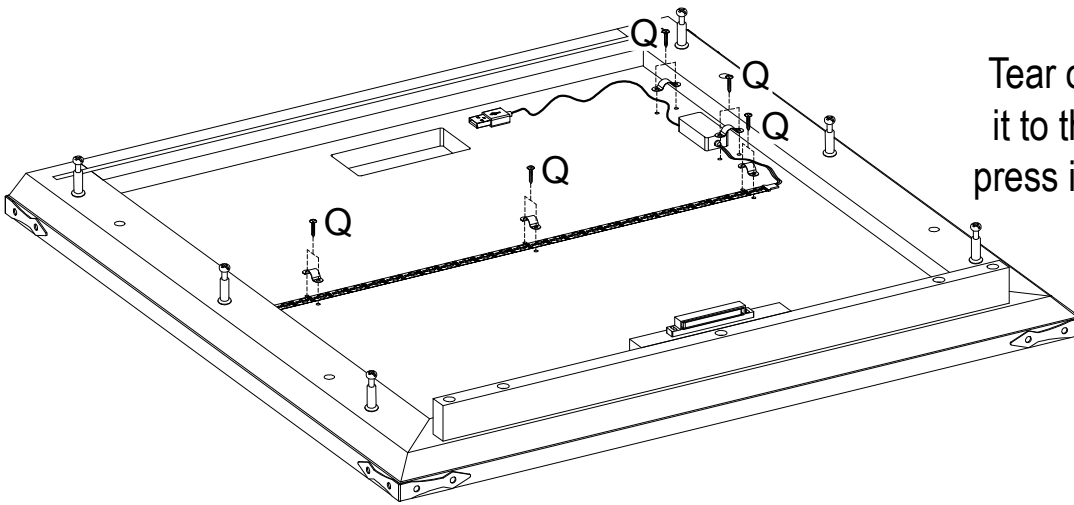

Remove the tape

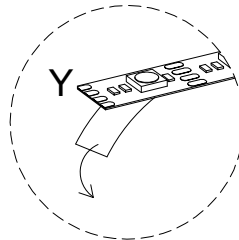

Press

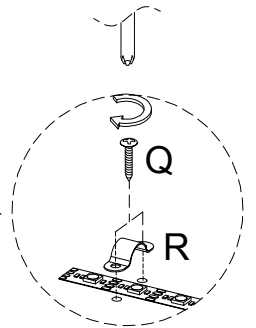
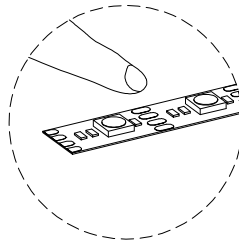

6

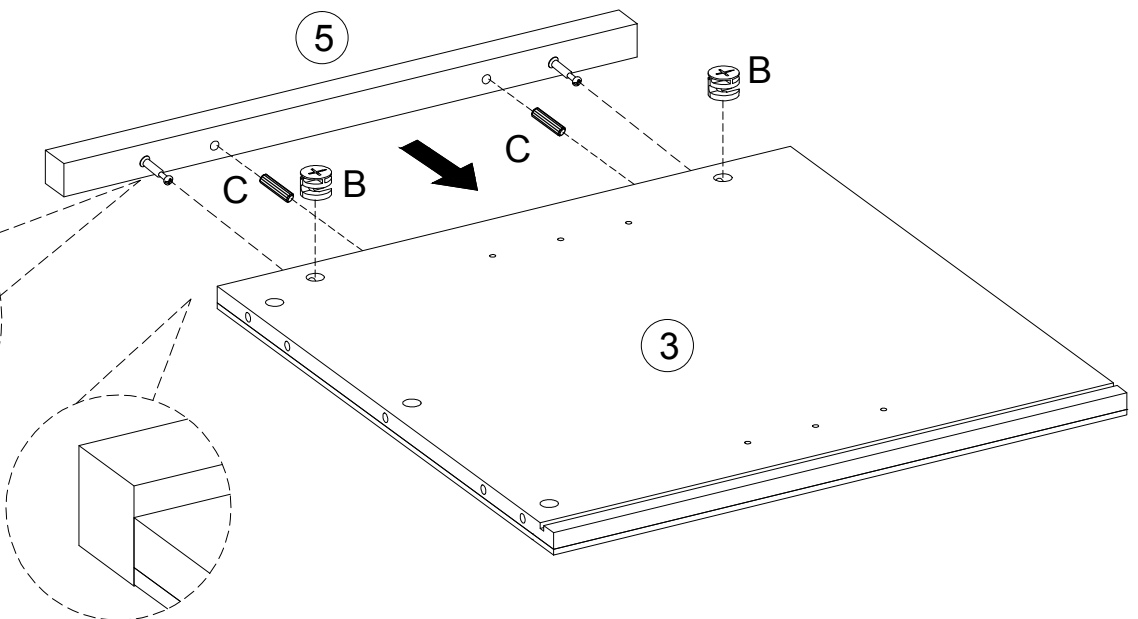
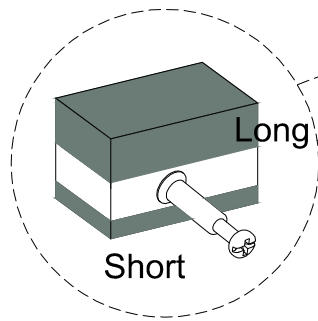
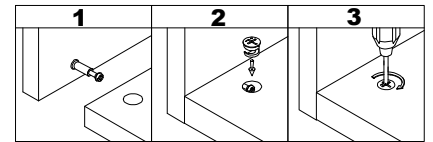
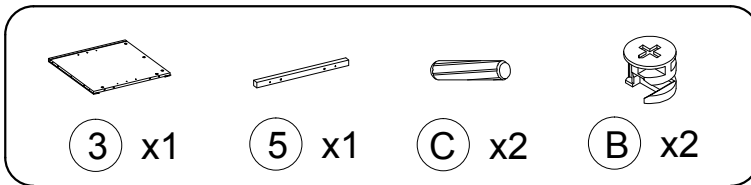

7

② x1 ⑤ x1 C x2 B x2

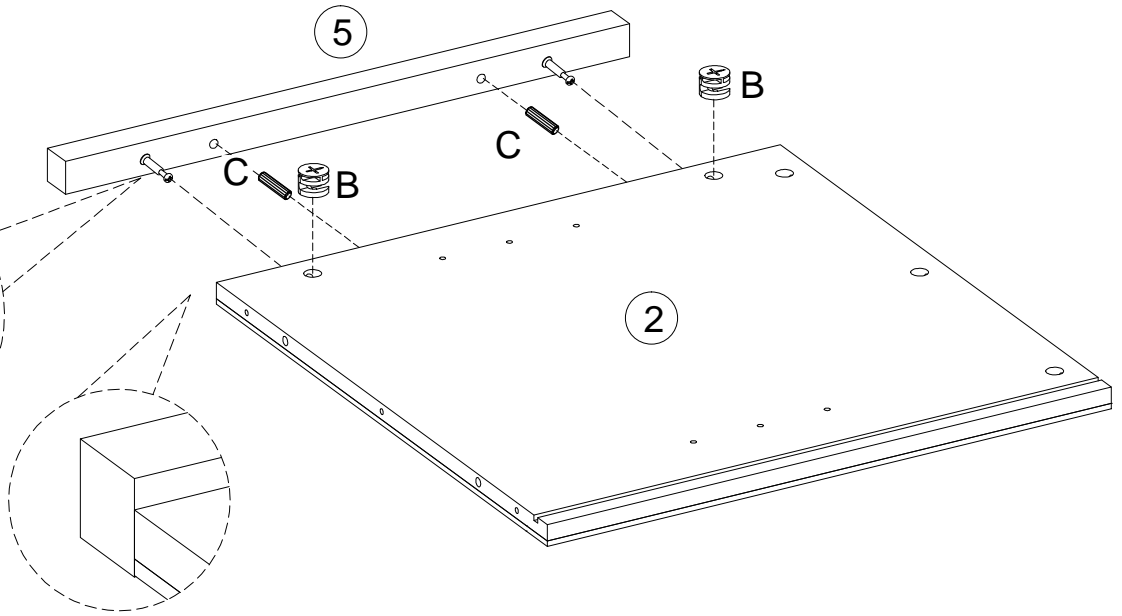
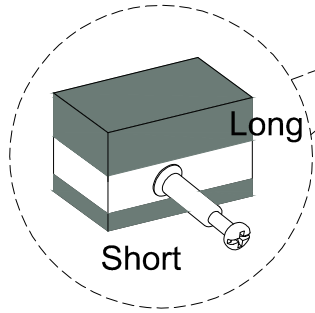
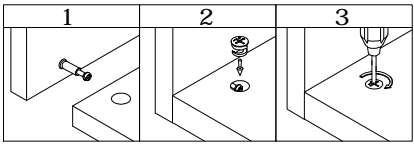

8

C x4 B x6

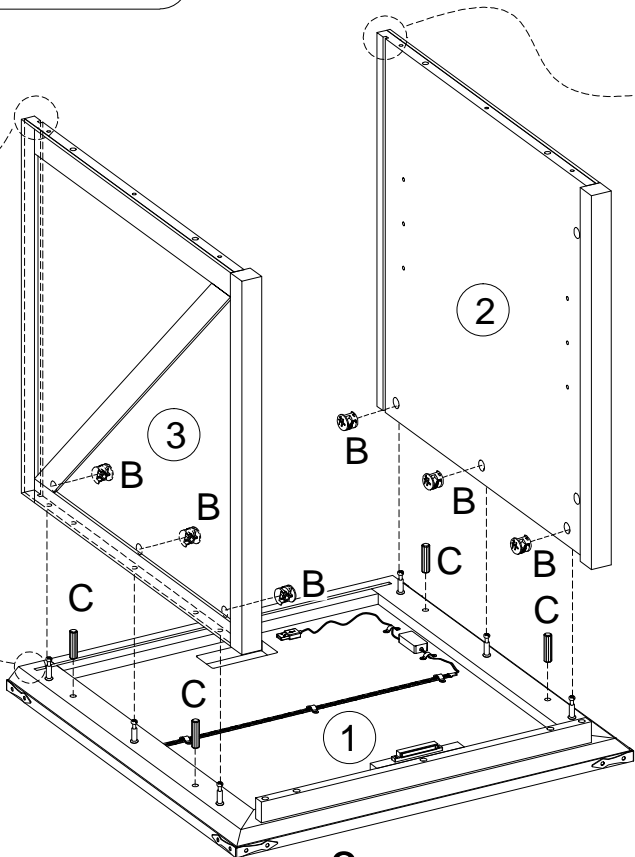
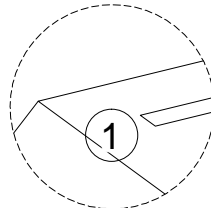
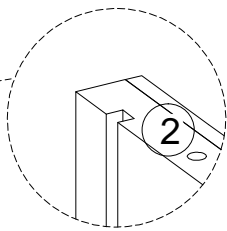
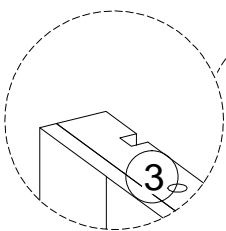
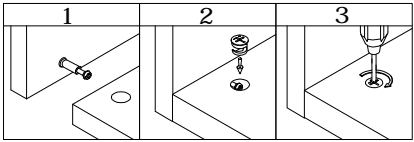

9

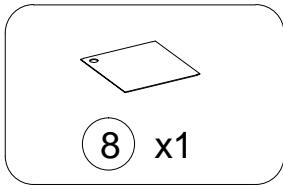

Pay attention to the orientation of the hole.

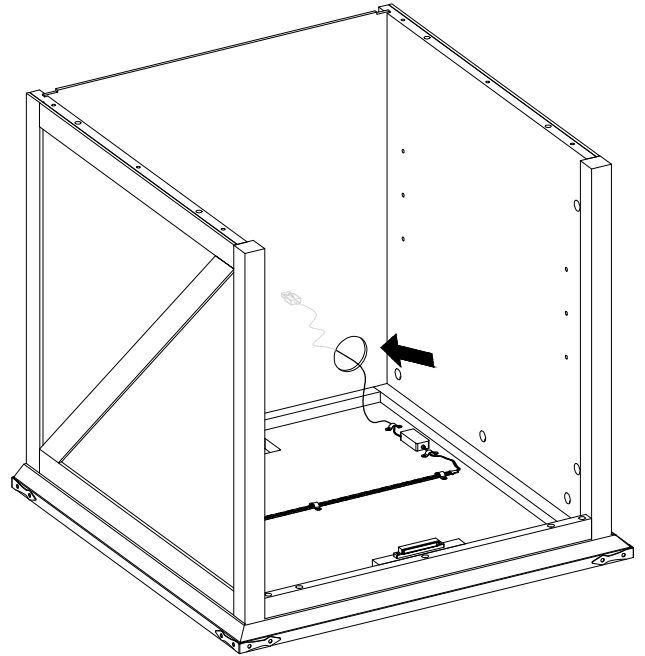
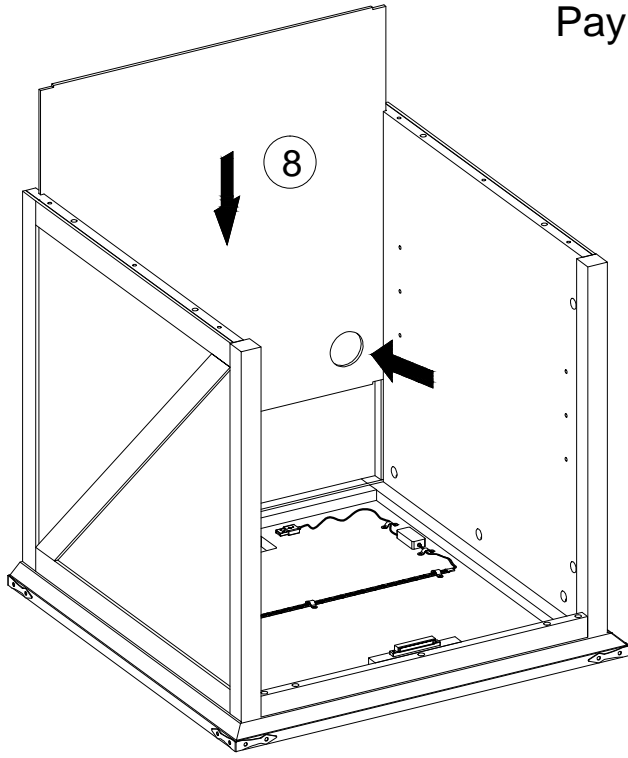

10

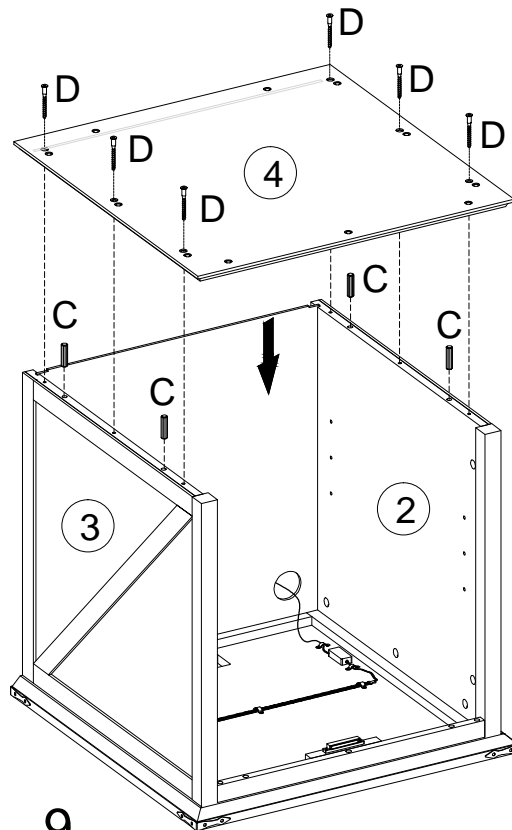
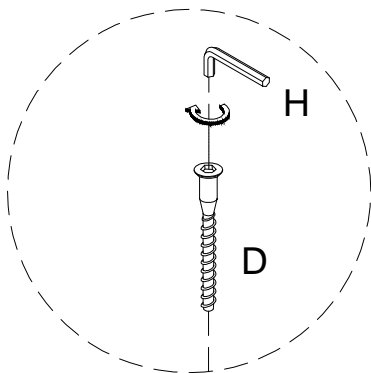
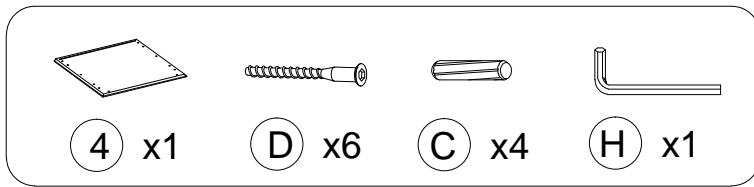

9

11



12 x1



14 x1



15 x1

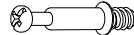

A x4

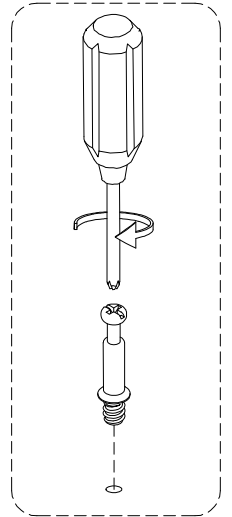
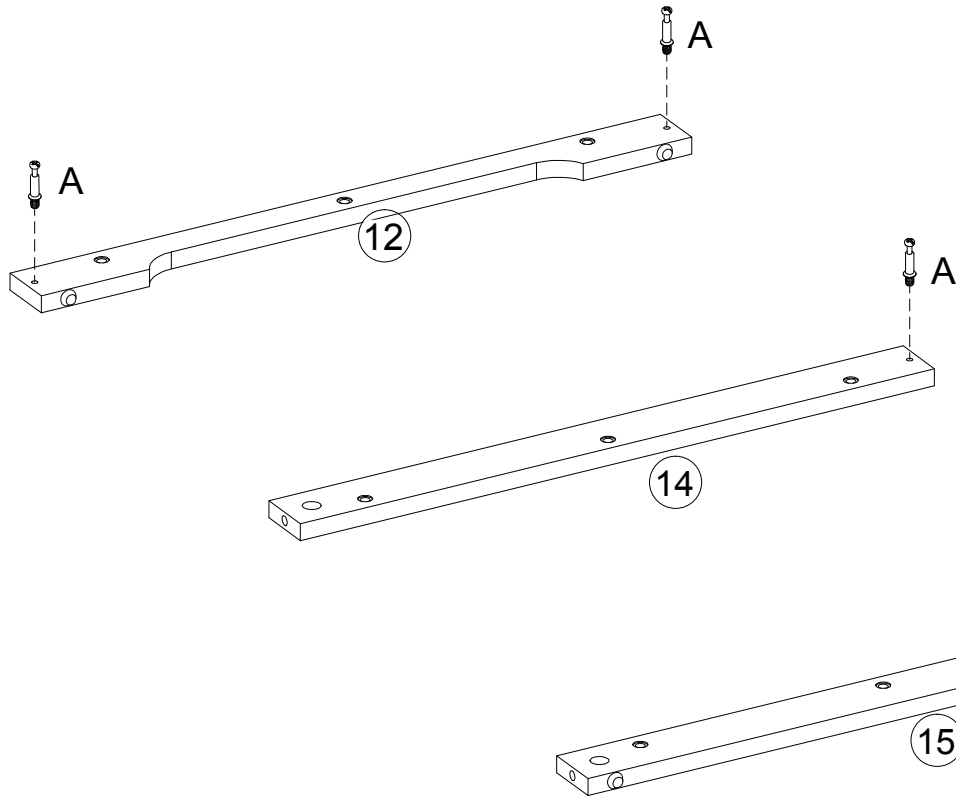

12



13 x1



J x11



I x11



H x1

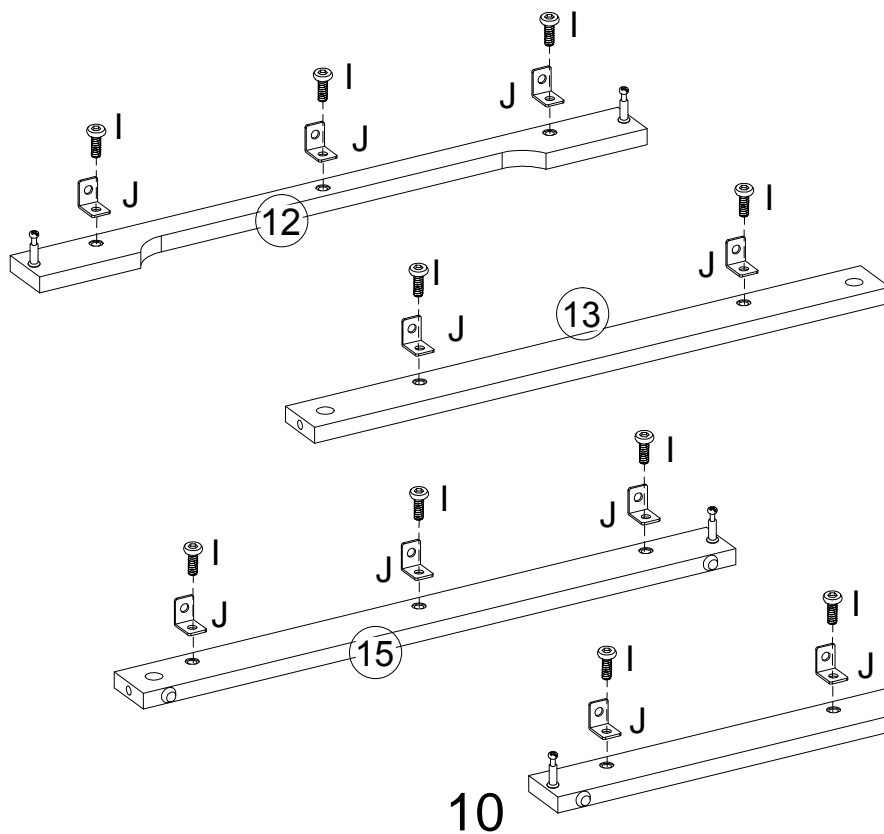

10

13

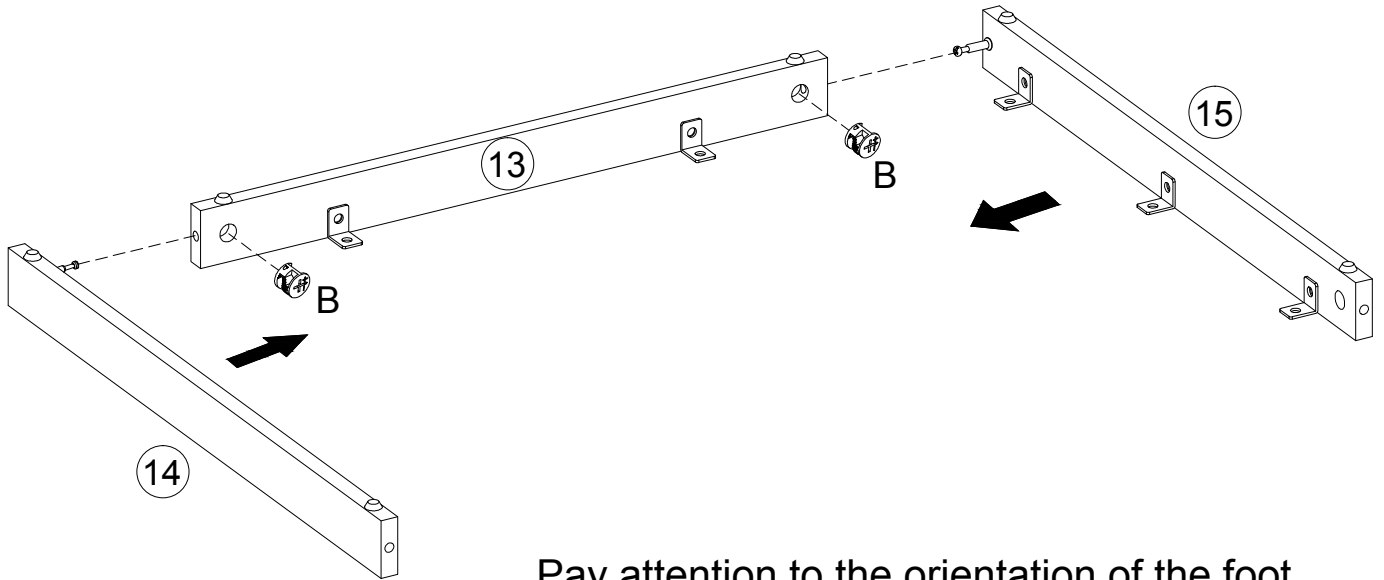
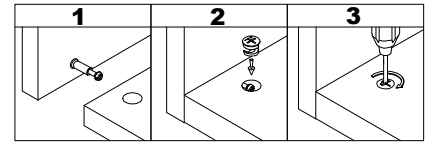
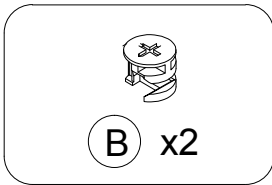

Pay attention to the orientation of the foot.

14

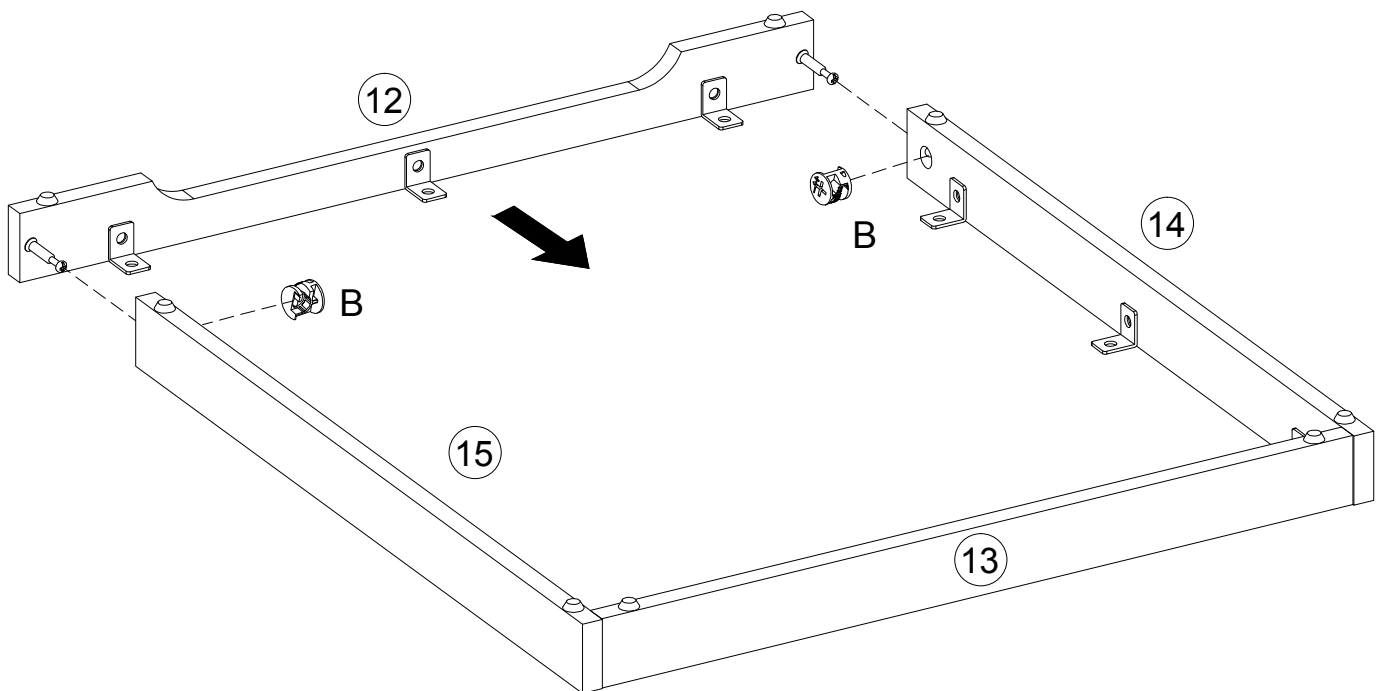
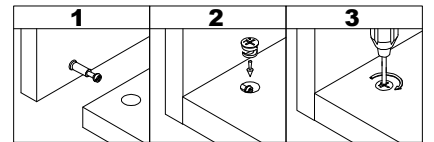
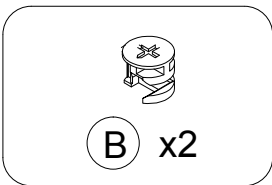

Pay attention to the orientation of the foot.

15



I x11



H x1

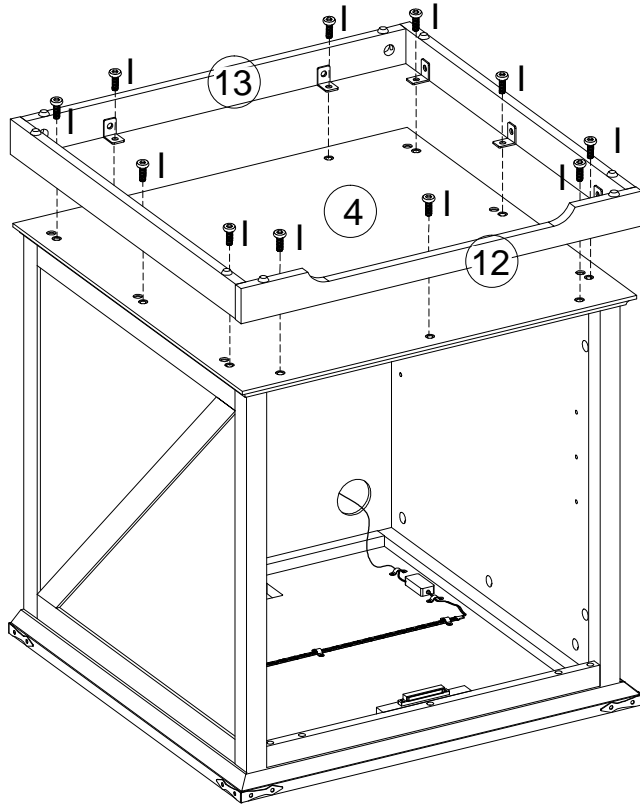
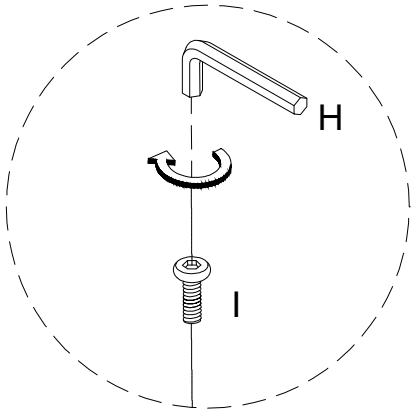

16



T x4



U x4

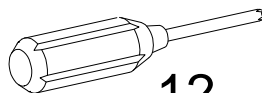
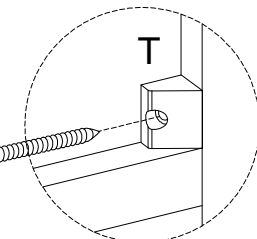
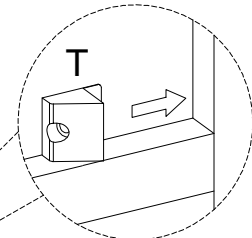
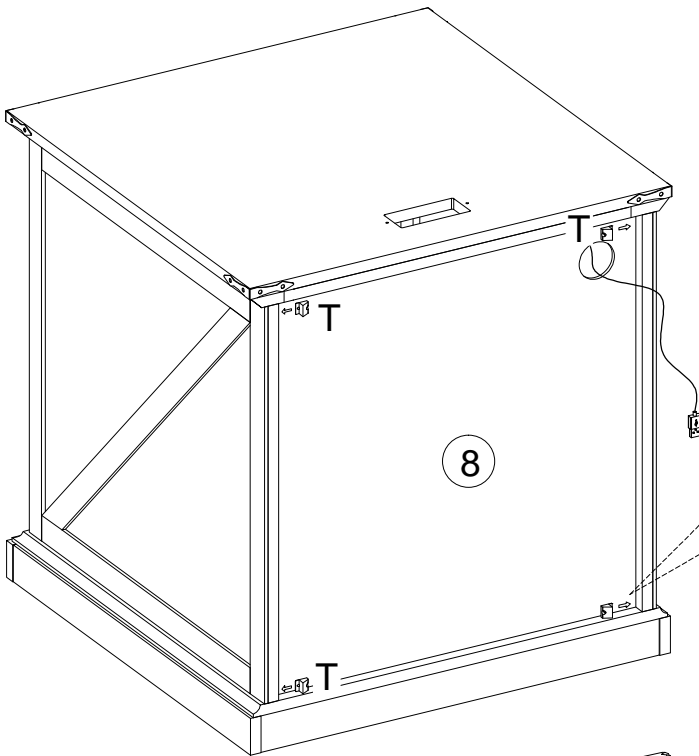

12

17

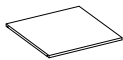

9 x1



S x4

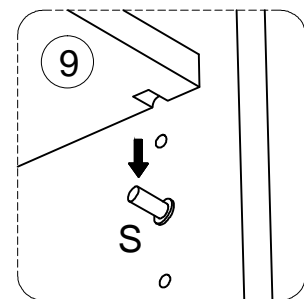
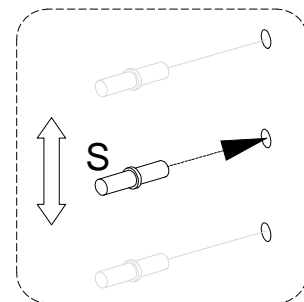
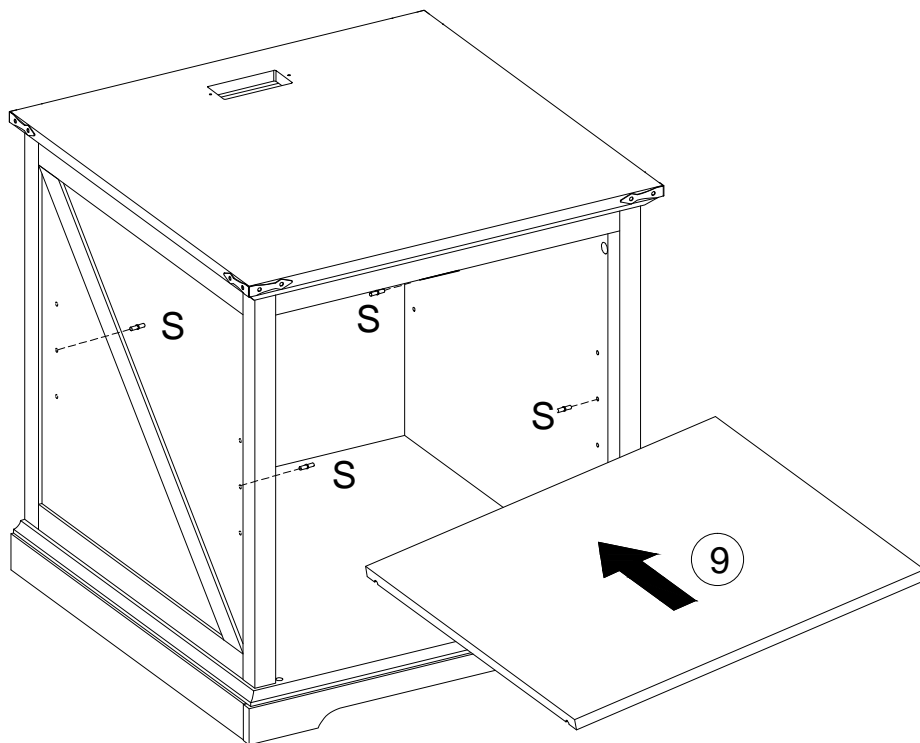

18



10 x1



L x1



N x1



Q x3



V x2



W x1

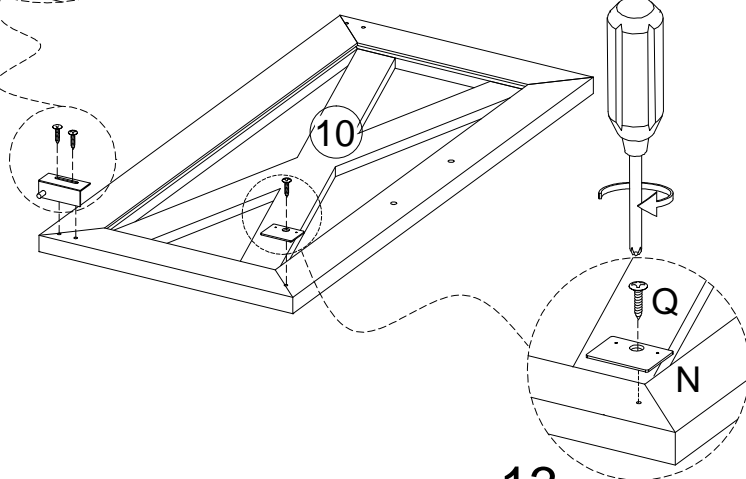
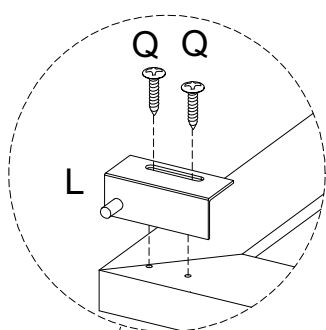

13

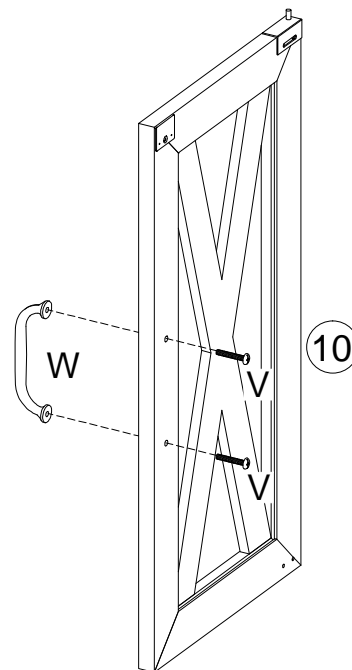

19



11 x1



M x1



N x1



Q x3



V x2



W x1

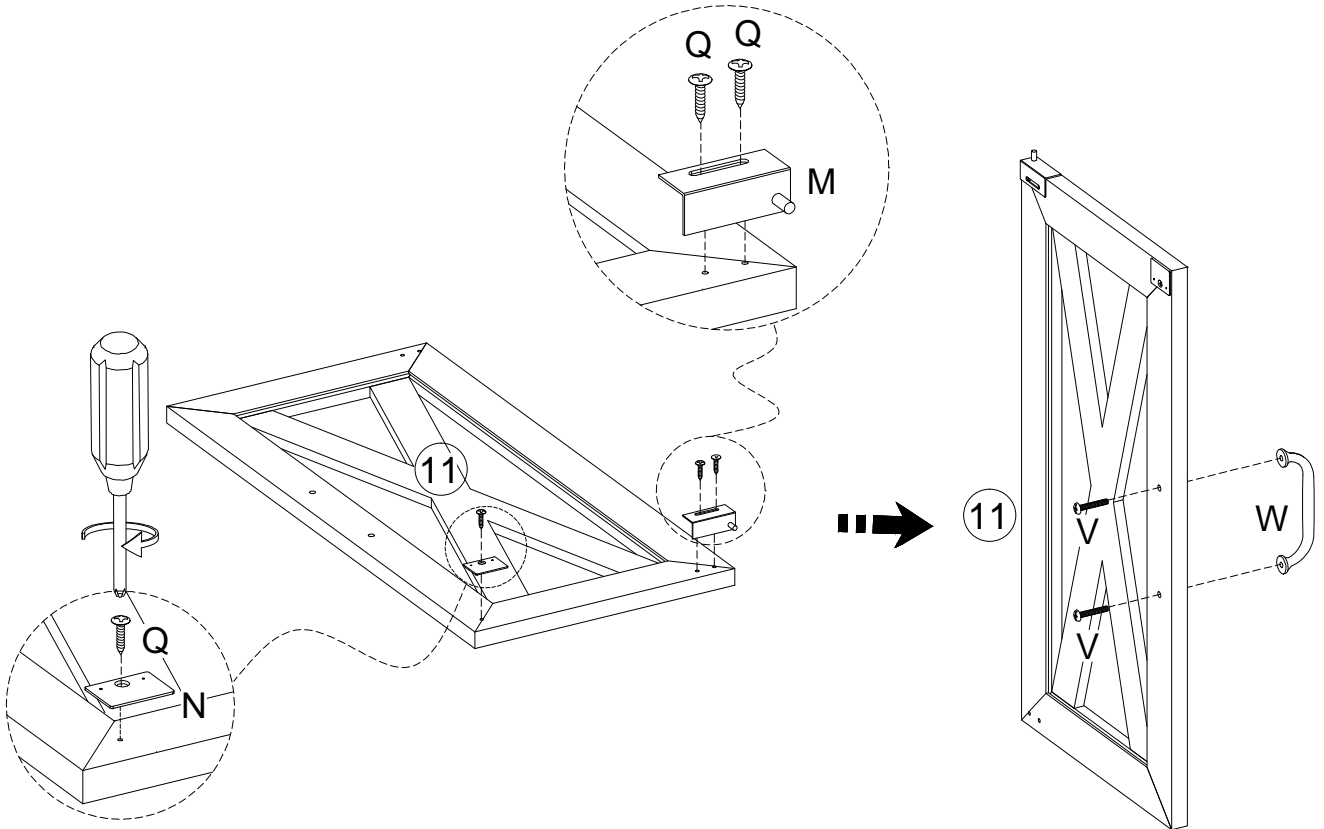

20



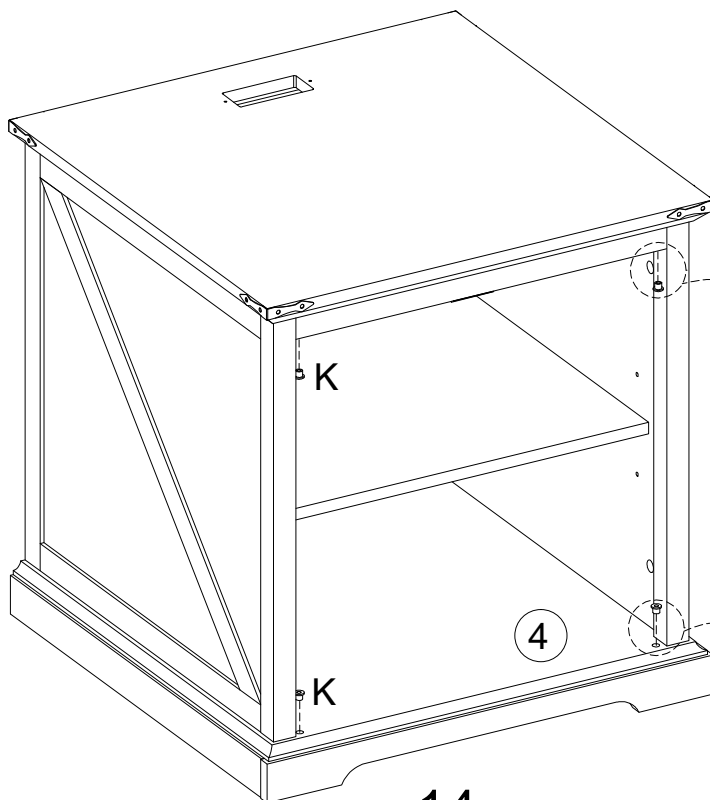

K x4





14

21

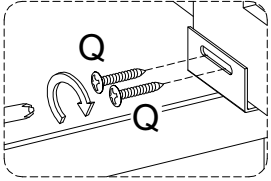
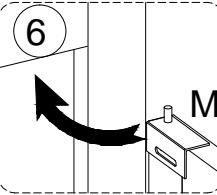
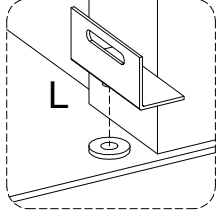
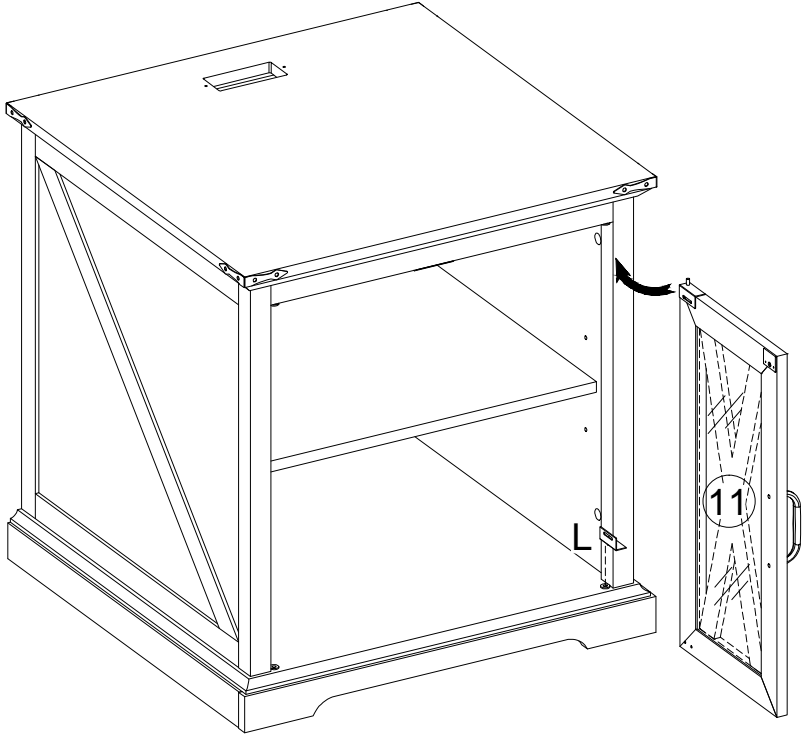
-  11 x1
-  L x1
-  Q x2



22

-  10 x1
-  M x1
-  Q x2

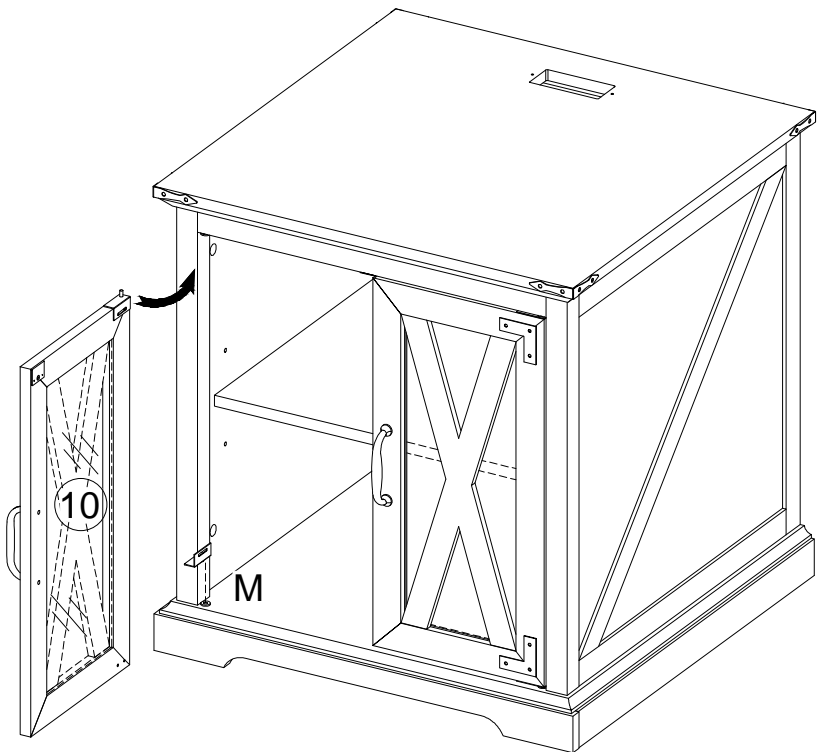
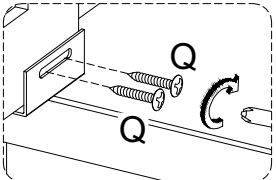
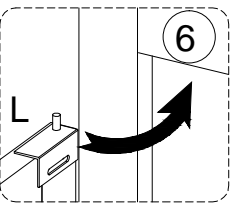
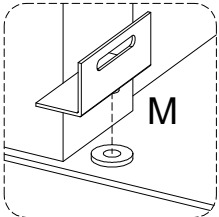

23

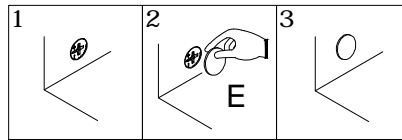
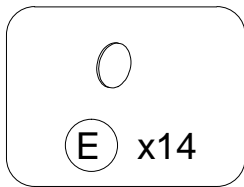

.Stick stickers (E) on cam locks (B).

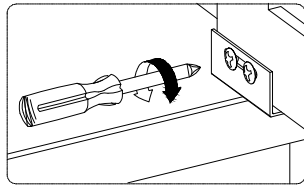

. To adjust side ways.
Loosen screws(Q) and adjust door, then tighten screws(Q).

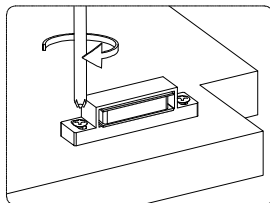
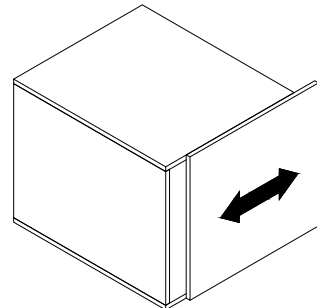

. To adjust depth.
Loosen screws(P) and adjust Magnetic catch(O), then tighten screws(F).

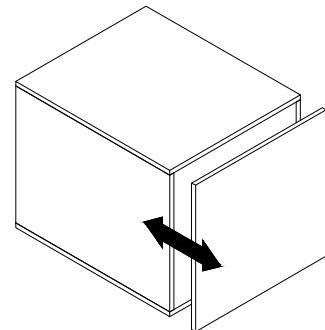

24

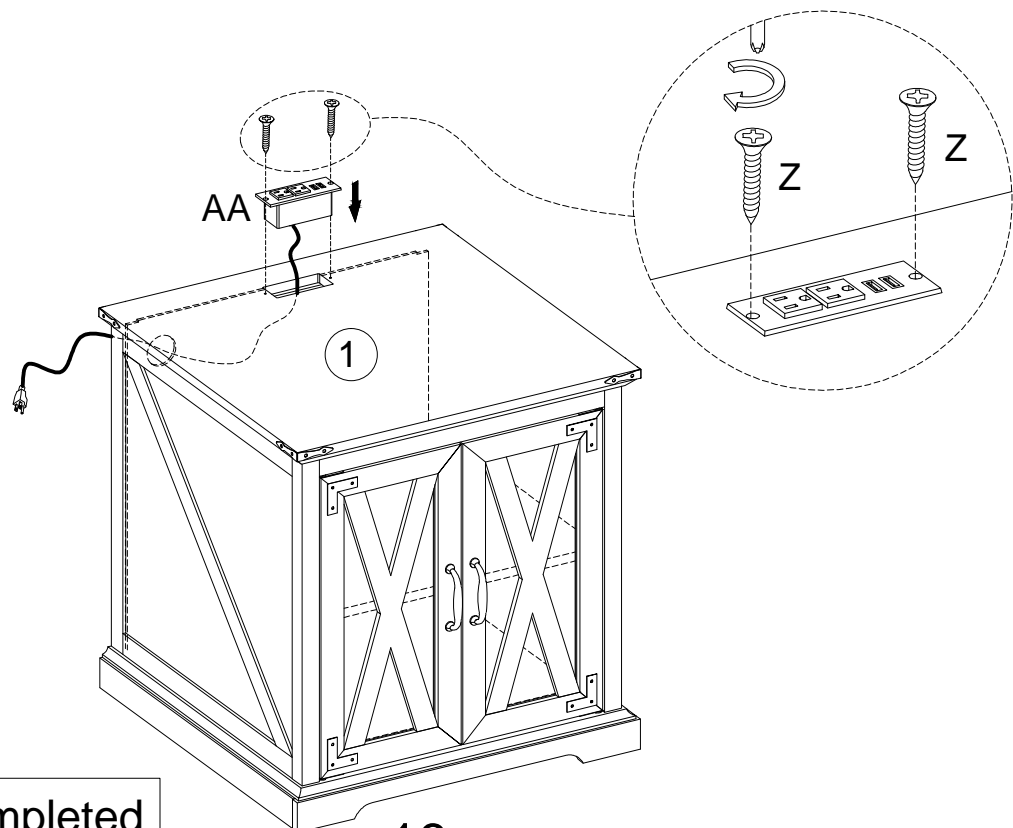
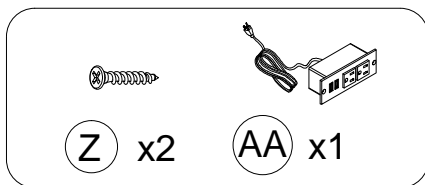

Installation Completed