

Warm Tips:

If you experience any issues with damaged or missing parts, or notice a quality defect, we kindly ask you to share the part number along with photos of the issue. Once we have reviewed and confirmed the details, we will provide appropriate solutions, including arranging a replacement. We sincerely appreciate your understanding and patience! This instruction booklet contains important safety information. please read and keep for future reference.

TIPS BEFORE YOU START

1. Before assembling your furniture, please check that all parts are present and laid out.
2. Before initiating each assembly step, please confirm required parts are identified.
3. Please ensure adequate space and assistance for safe assembly of large items.
4. We recommend assembling the product near its intended placement area to avoid relocation after assembly.
5. We recommend to place components on soft surfaces (e.g., carpet, blanket) during assembly to prevent damage of the item.
6. Please do not overtighten any fittings, as this may damage the product. We recommend hand-tightening rather than using power tools.
7. Please position fully assembled product on flat, stable surfaces with even support.
8. Please do not stand on or use this product as a step ladder.
9. Product is designed exclusively for indoor household use in non-industrial environments.
10. Please lift with proper body mechanics to prevent injury and product damage.

CARE AND MAINTENANCE OF YOUR FURNITURE

- ☑ Periodically inspect and retighten all fittings as needed to maintain structural integrity.
- ☑ Periodically inspect all screws and retighten if necessary to maintain product stability.
- ☑ For optimal glass cleaning, apply a dedicated glass cleaner using a microfiber cloth to prevent streaks.
- ☑ Avoid liquid contact to prevent structural warping and surface delamination; immediately wipe any spills.
- ☑ Avoid placing hot objects (e.g., hot beverages) directly onto surfaces to prevent thermal shock and permanent discoloration.
- ☑ Lift the unit with multiple personnel using proper technique; dragging or pushing risks structural failure and injury.

ASSEMBLY REQUIREMENTS

- ☑ Equipment: phillips head screwdriver.
- ☑ 2 x adults required.
- ☑ 2m x 2m assembly space required.
- ☑ 1.5 hour assembly time approx.

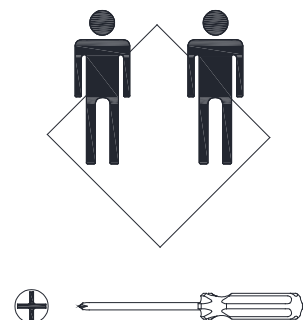

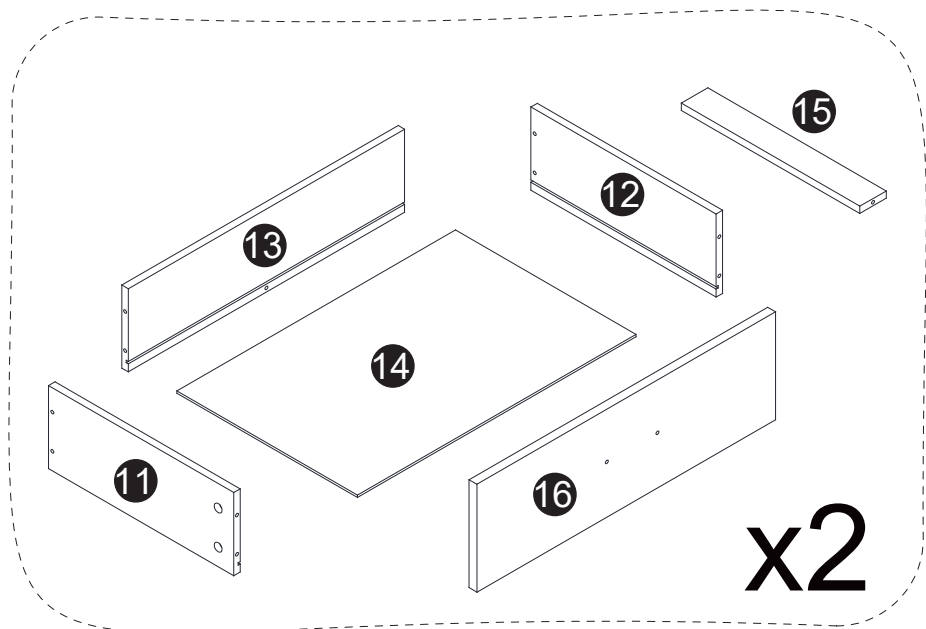
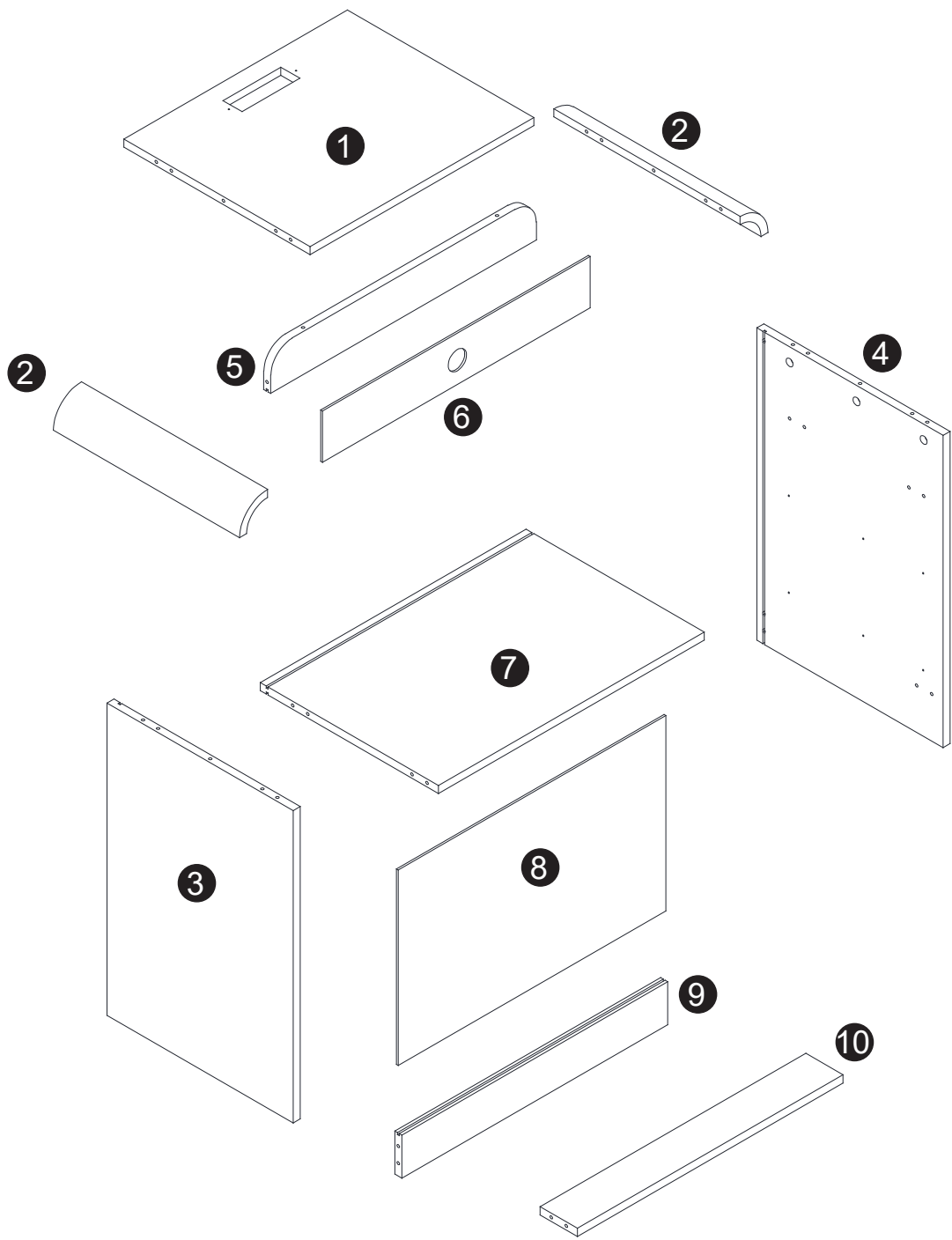

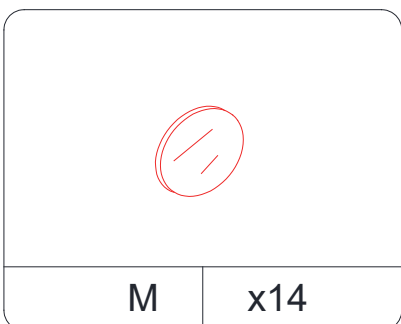
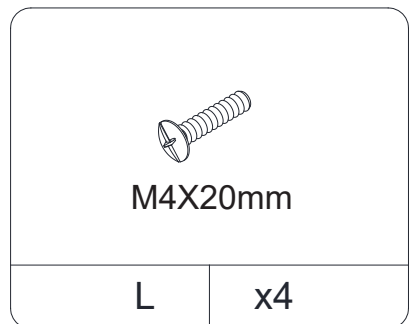
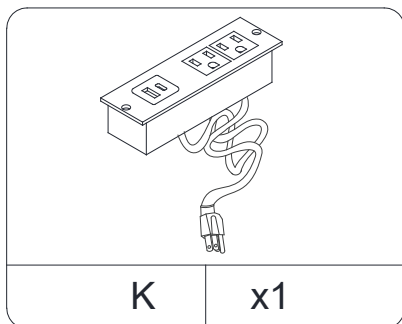
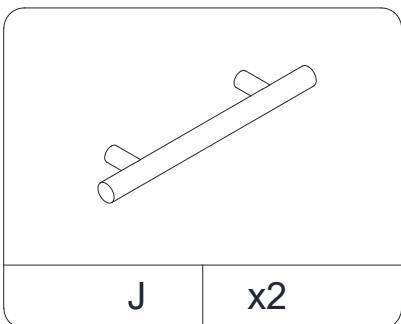
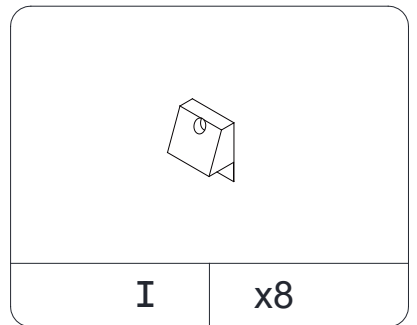
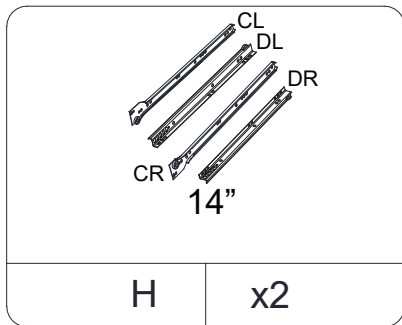
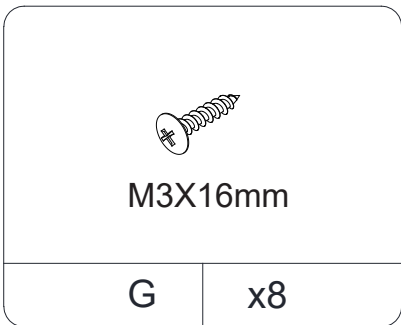
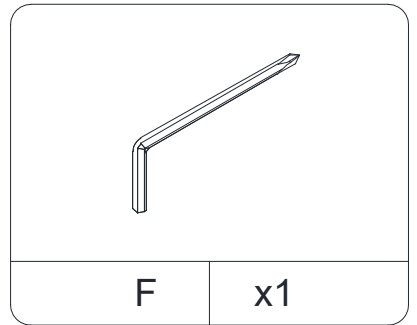
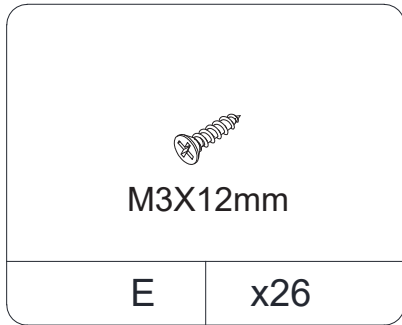
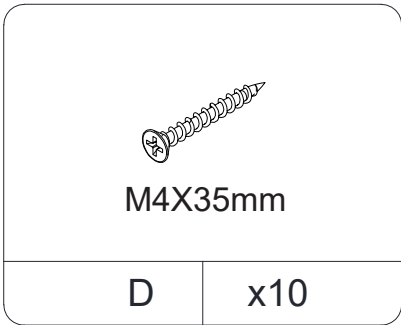
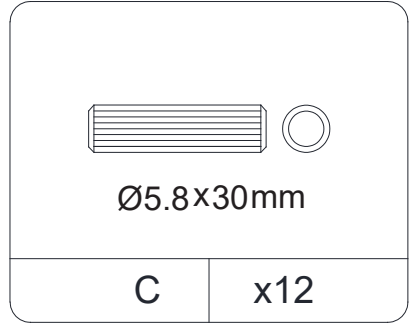
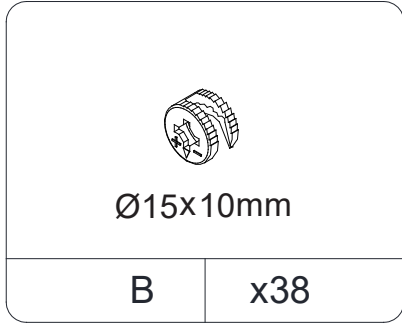
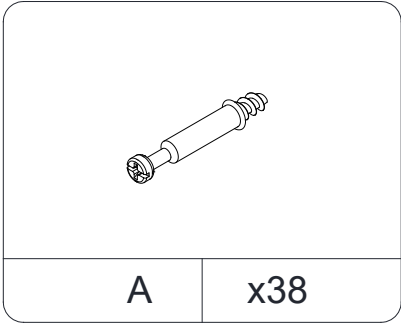

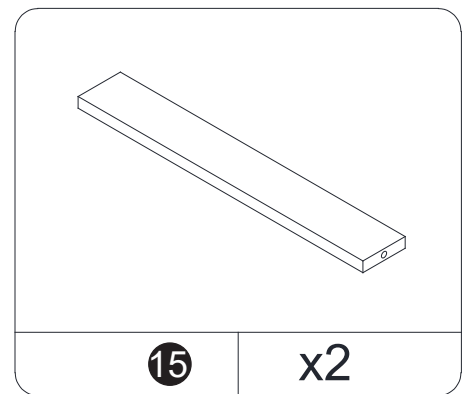
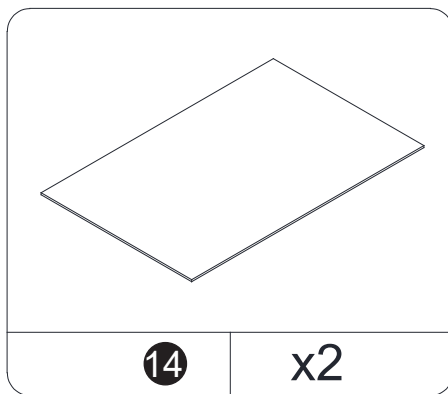
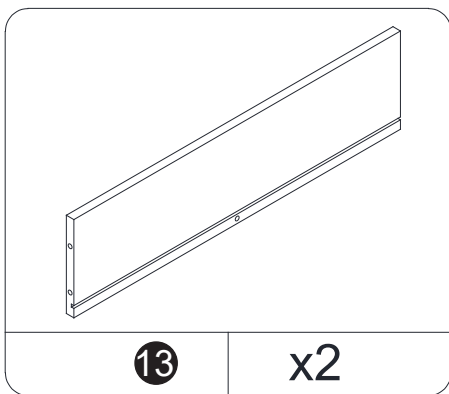
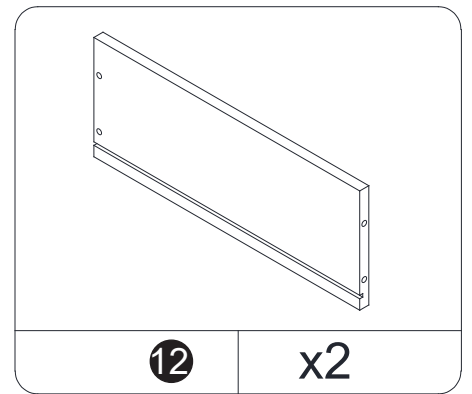
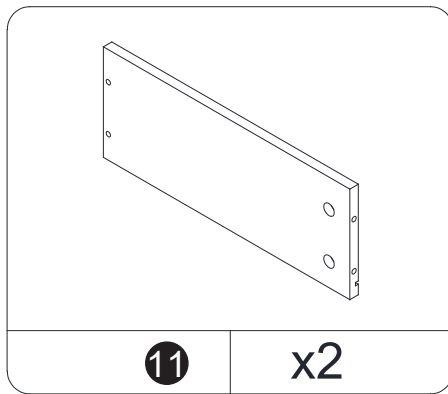
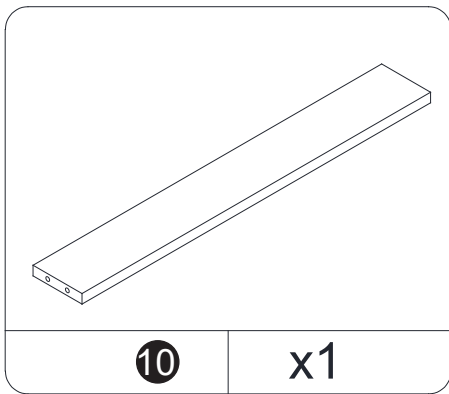
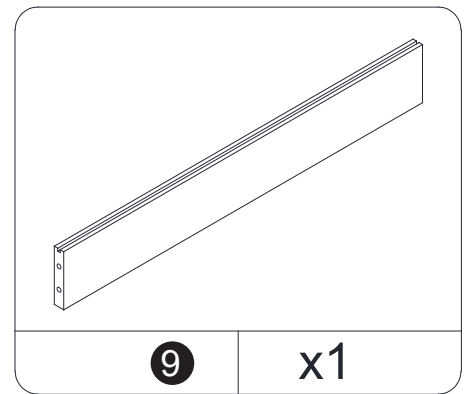
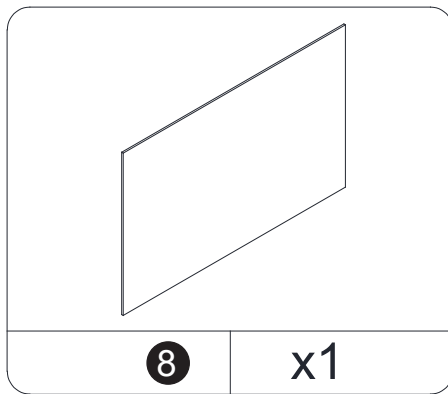
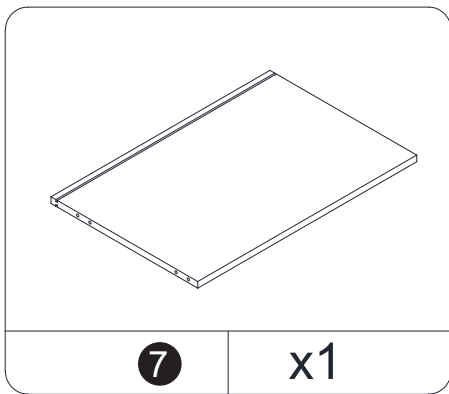
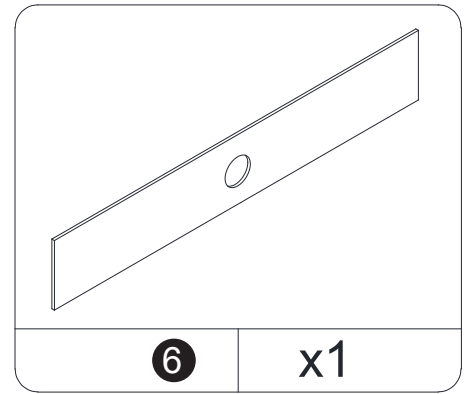
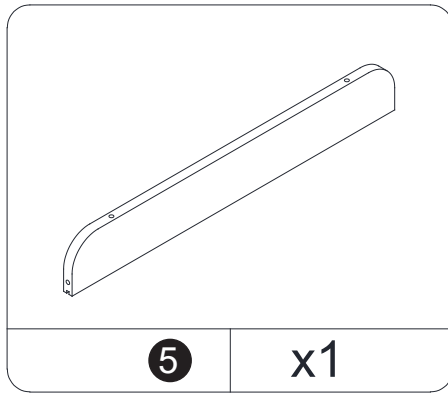
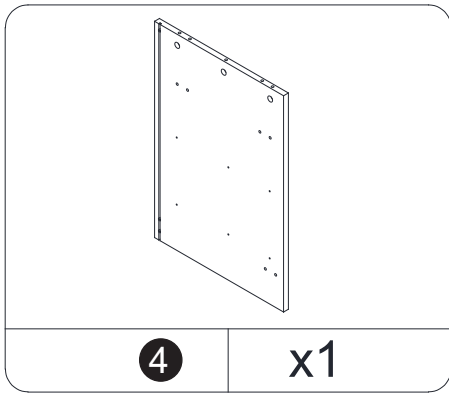
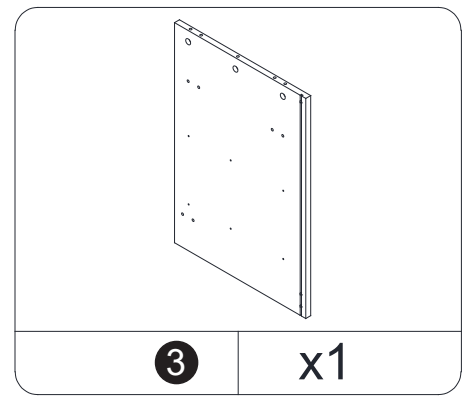
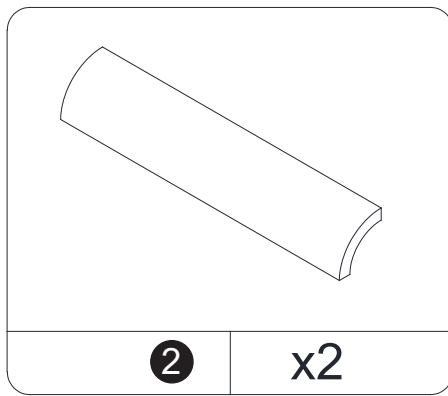
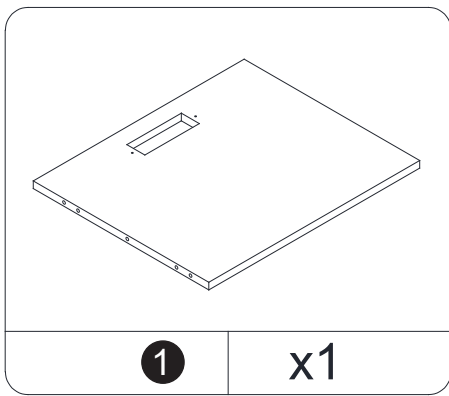

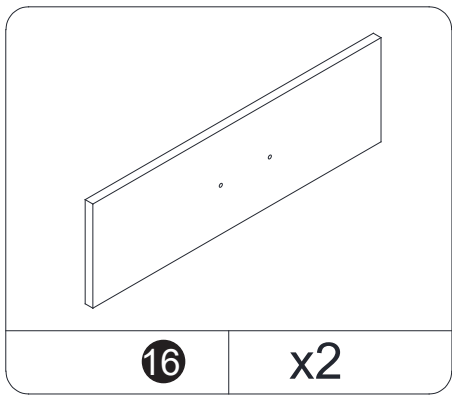



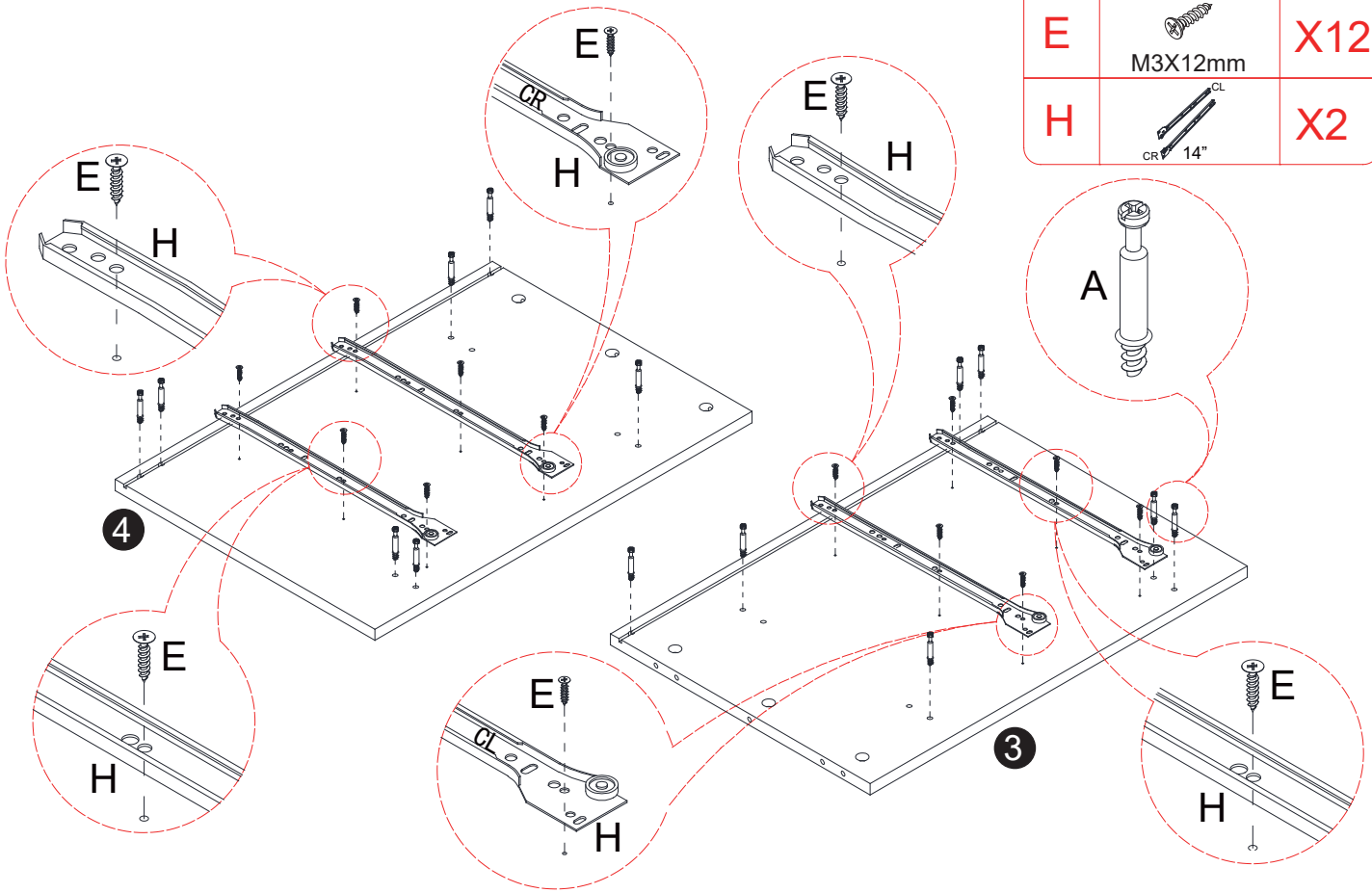

Step 1

A		X14
E	 M3X12mm	X12
H	 CR 14"	X2



Step 2

A		X14
---	---	-----

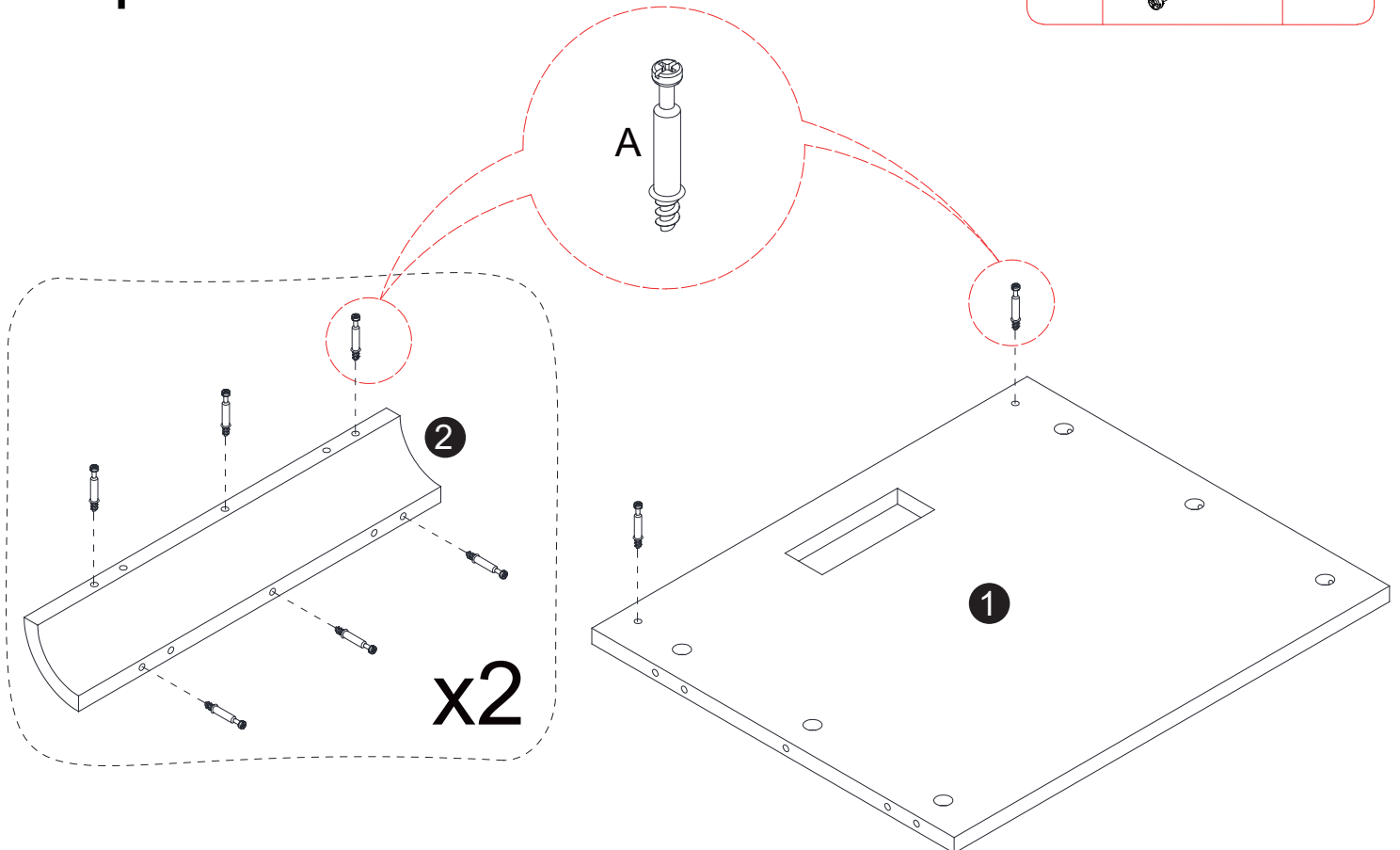

Step 3

B	 Ø15x10mm	X2
----------	---	-----------

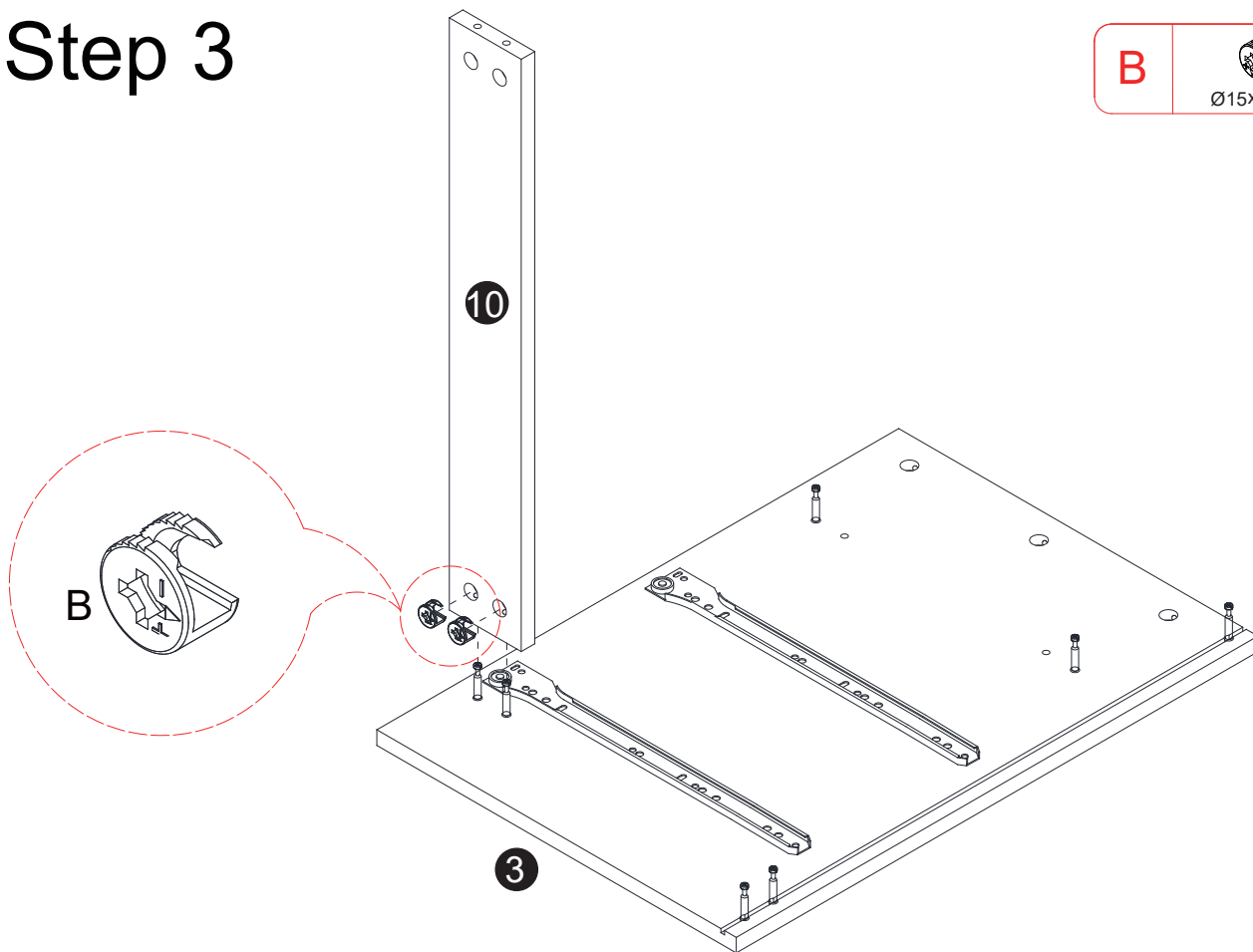

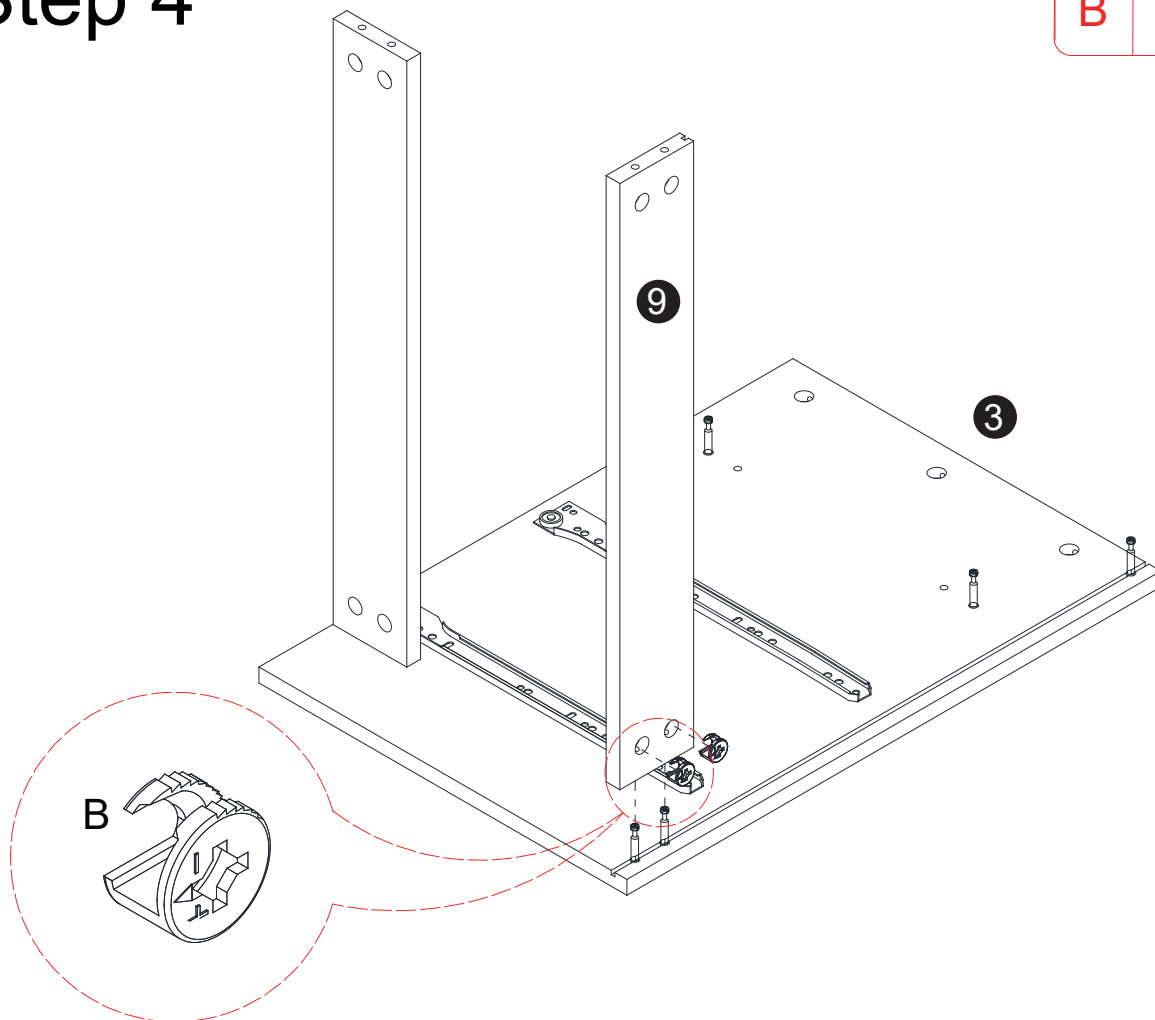

Step 4

B	 Ø15x10mm	X2
----------	---	-----------

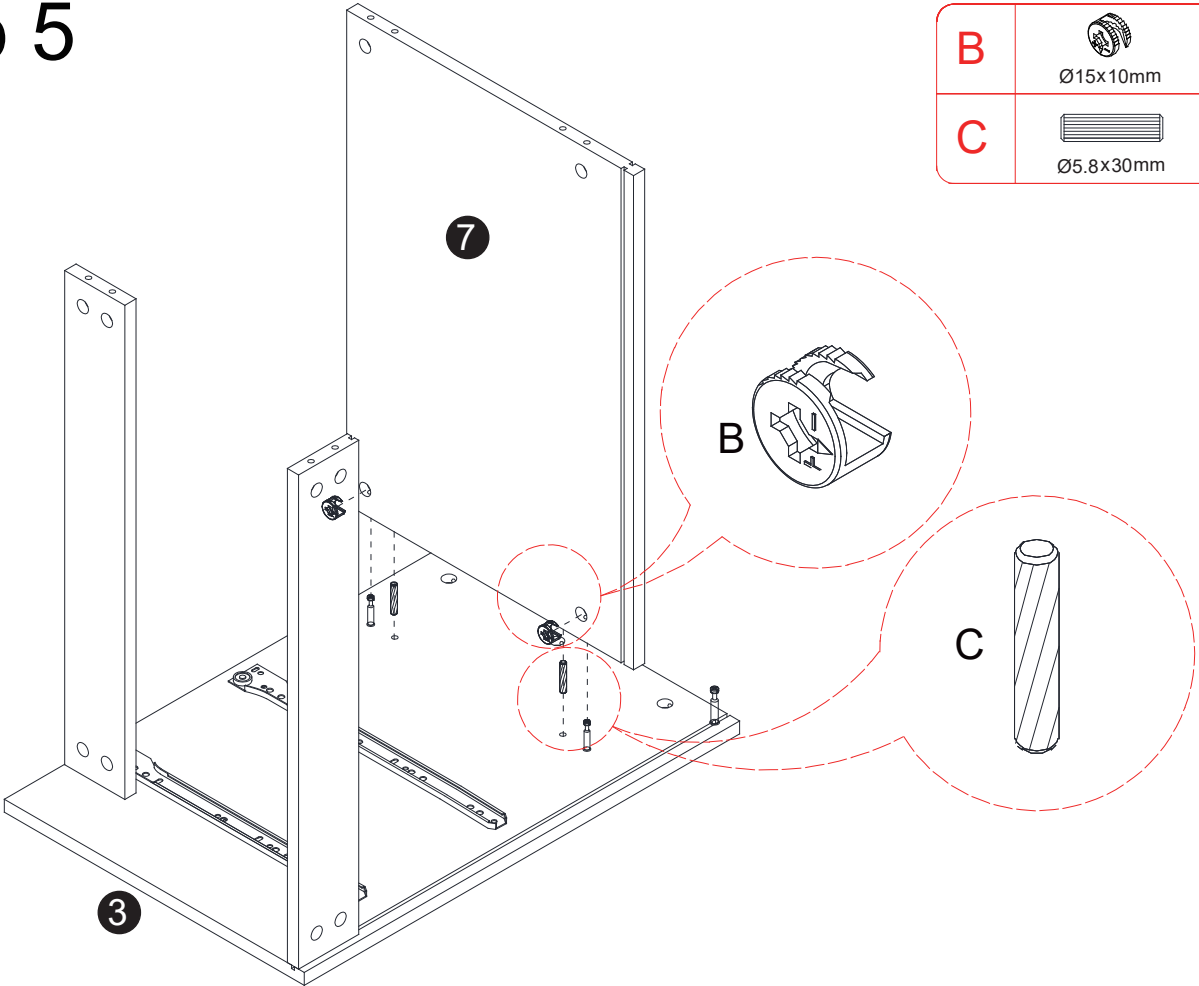

Step 5



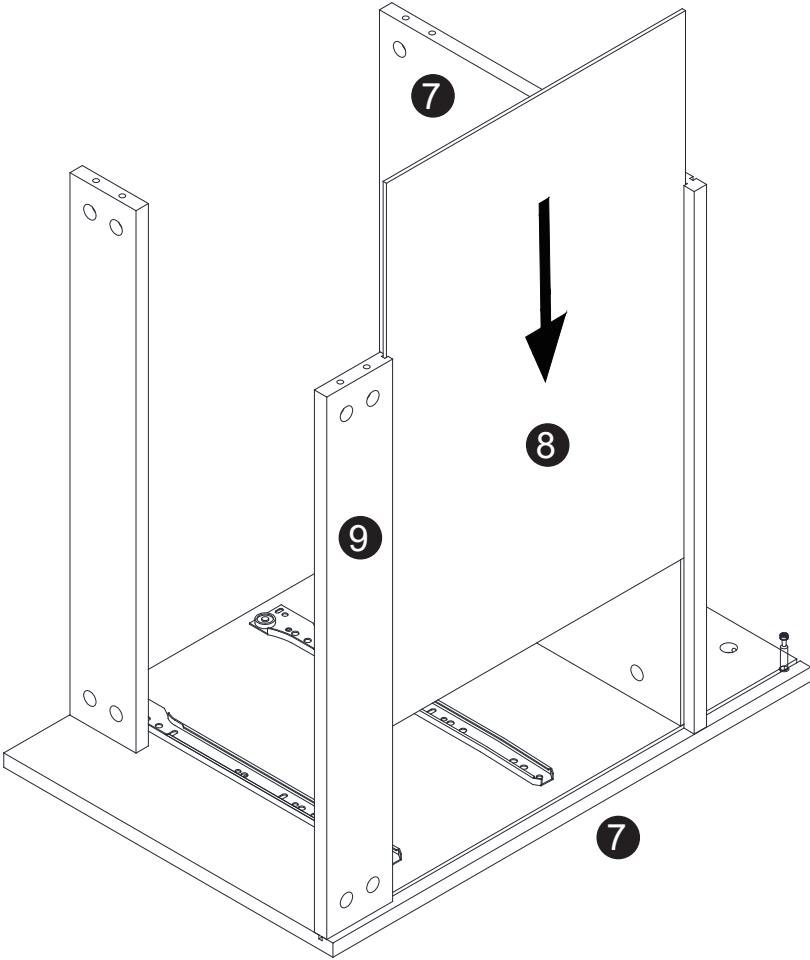

B	 Ø15x10mm	X2
C	 Ø5.8x30mm	X2

Step 6



Step 7

B	 Ø15x10mm	X8
C	 Ø5.8x30mm	X2

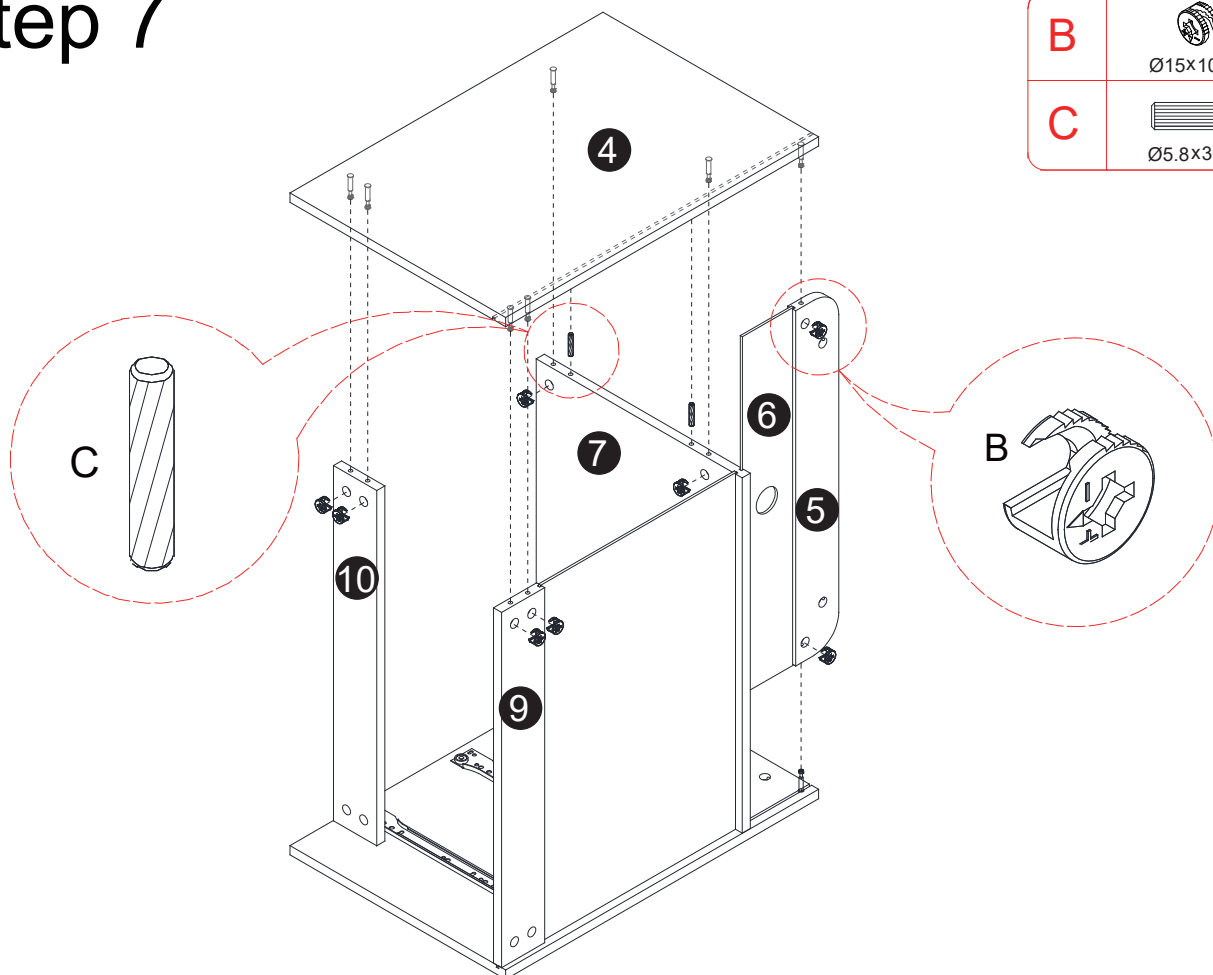

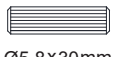

Step 8

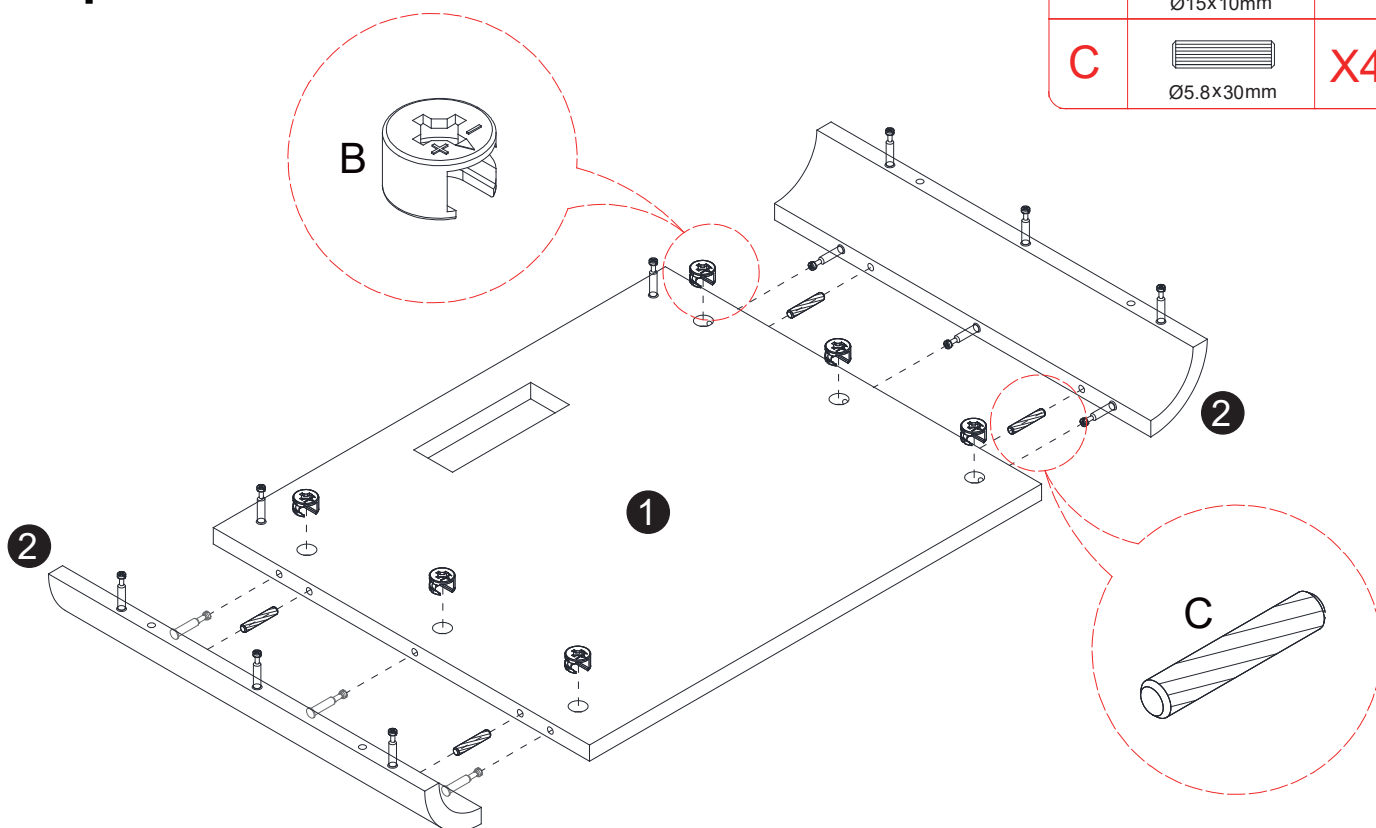
B	 Ø15x10mm	X6
C	 Ø5.8x30mm	X4



Step 9

B	 Ø15x10mm	X8
C	 Ø5.8x30mm	X4
M		X6

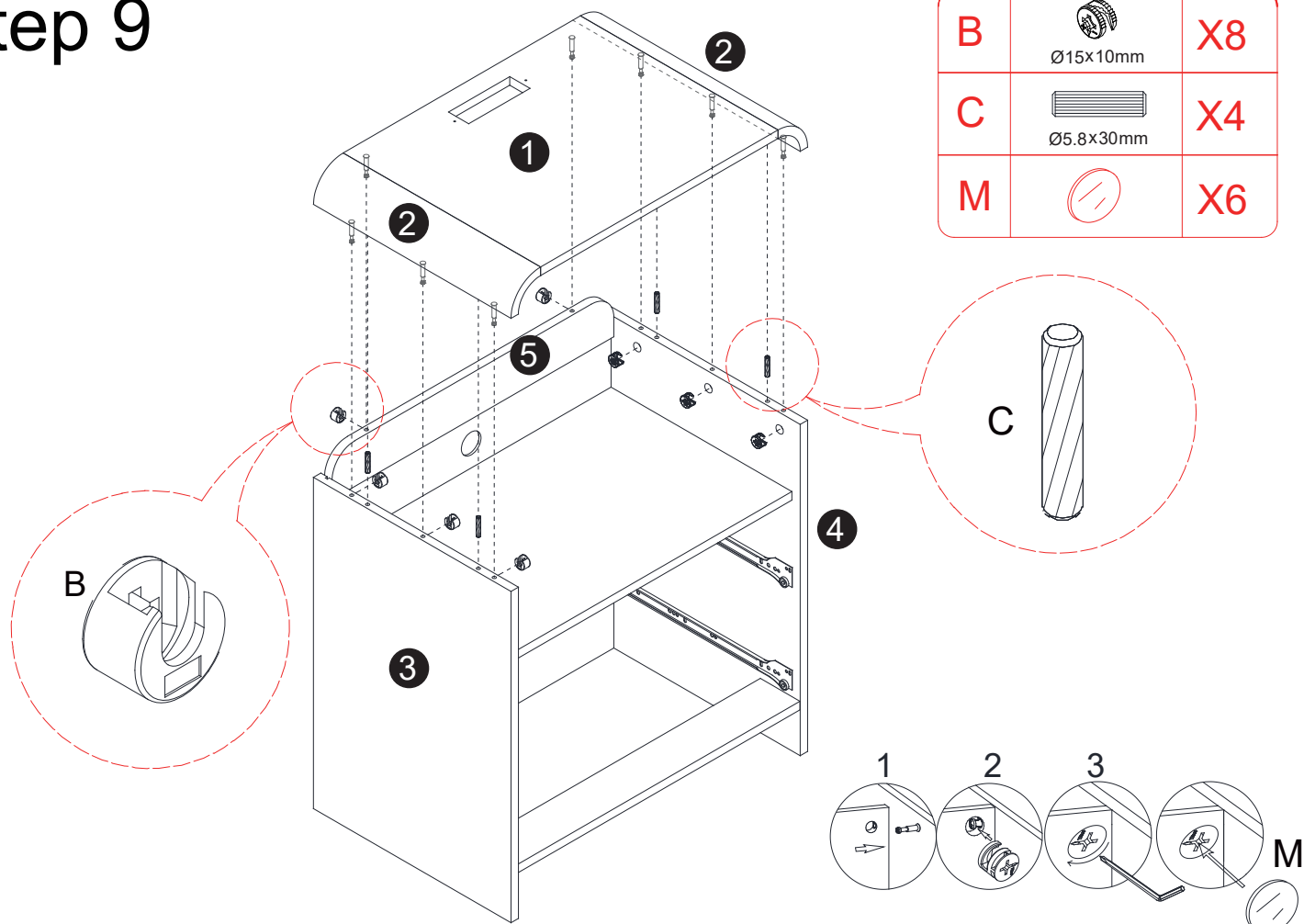

Step 10

D	 M4X35mm	X8
----------	--	-----------

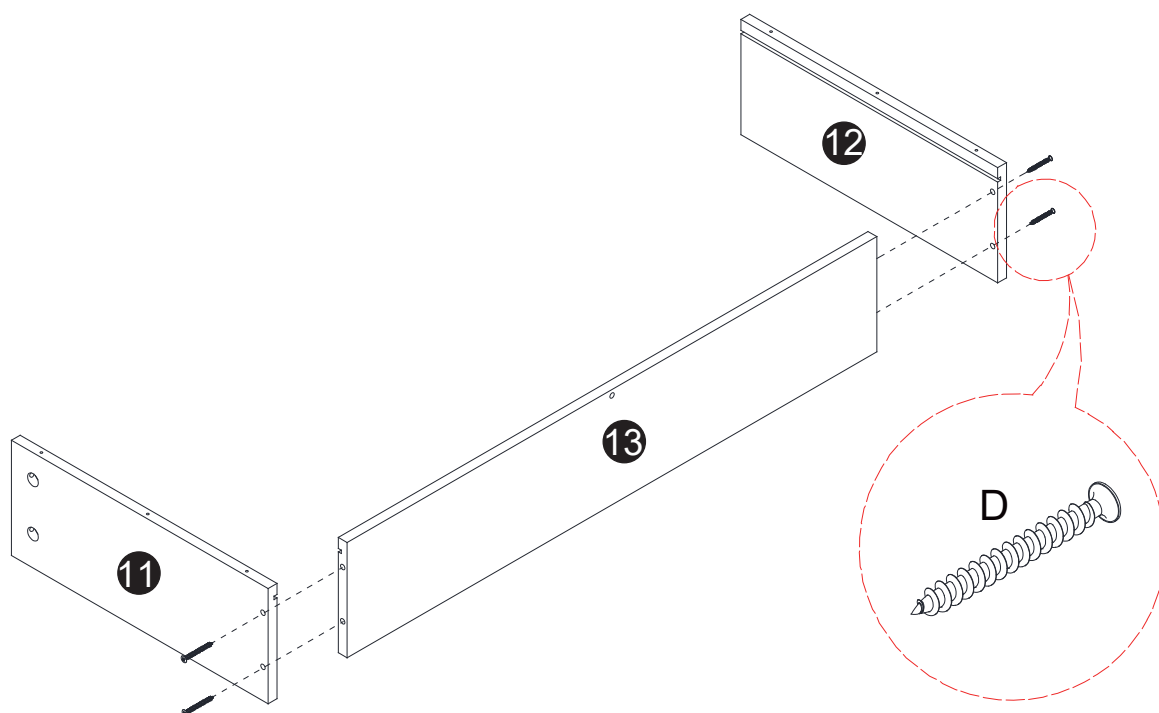

x2

Step 11

D	 M4X35mm	X2
---	--	----

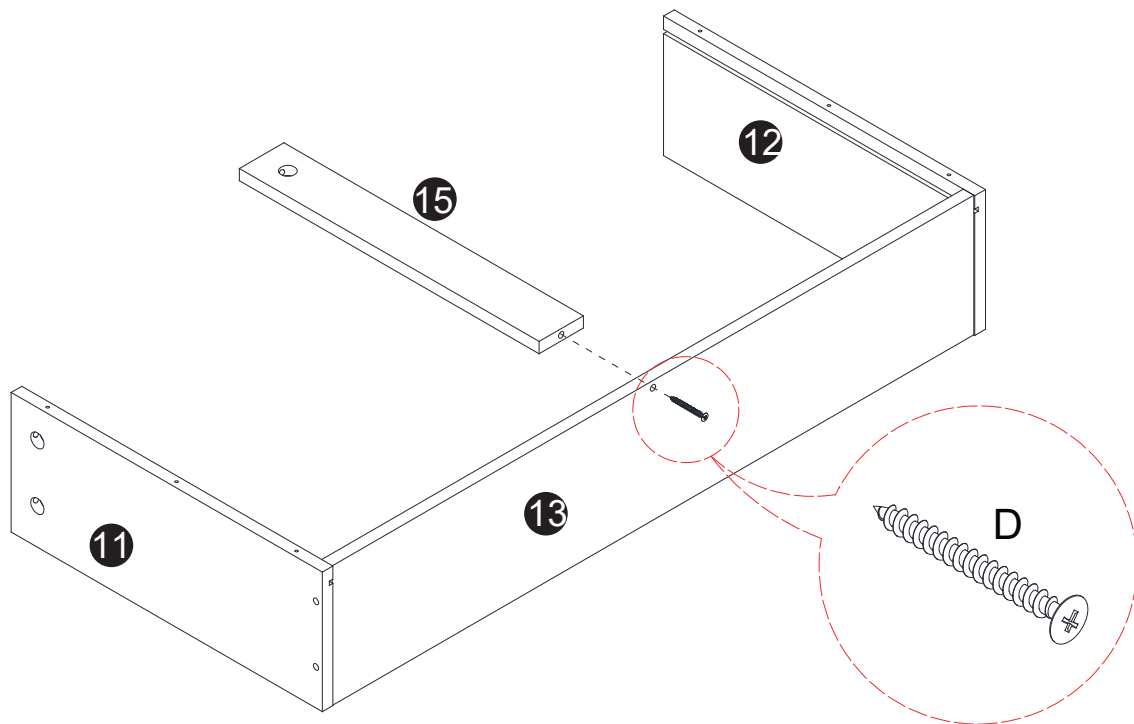

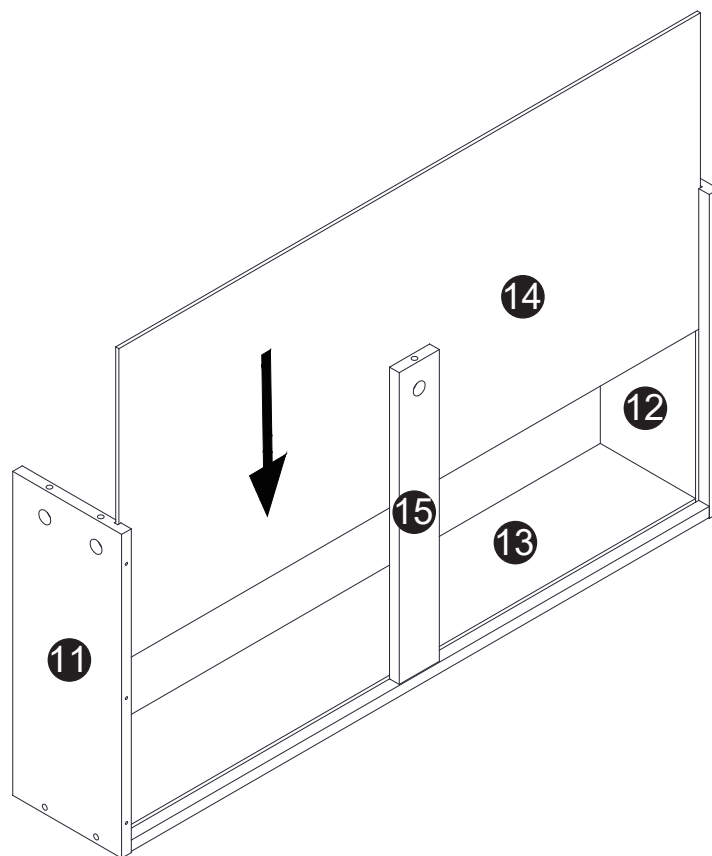

x2

Step 12



x2

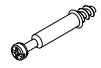
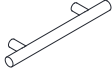

Step 13

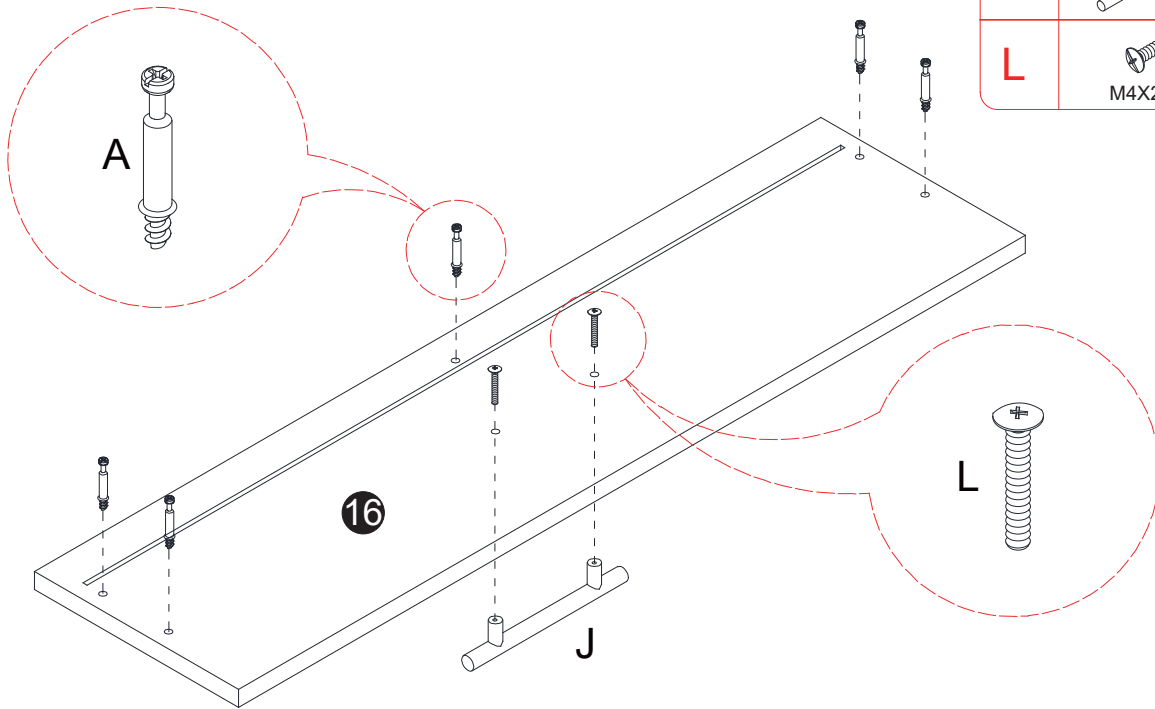
A		X10
J		X2
L	 M4X20mm	X4



x2

Step 14

B	 Ø15x10mm	X10
M		X8

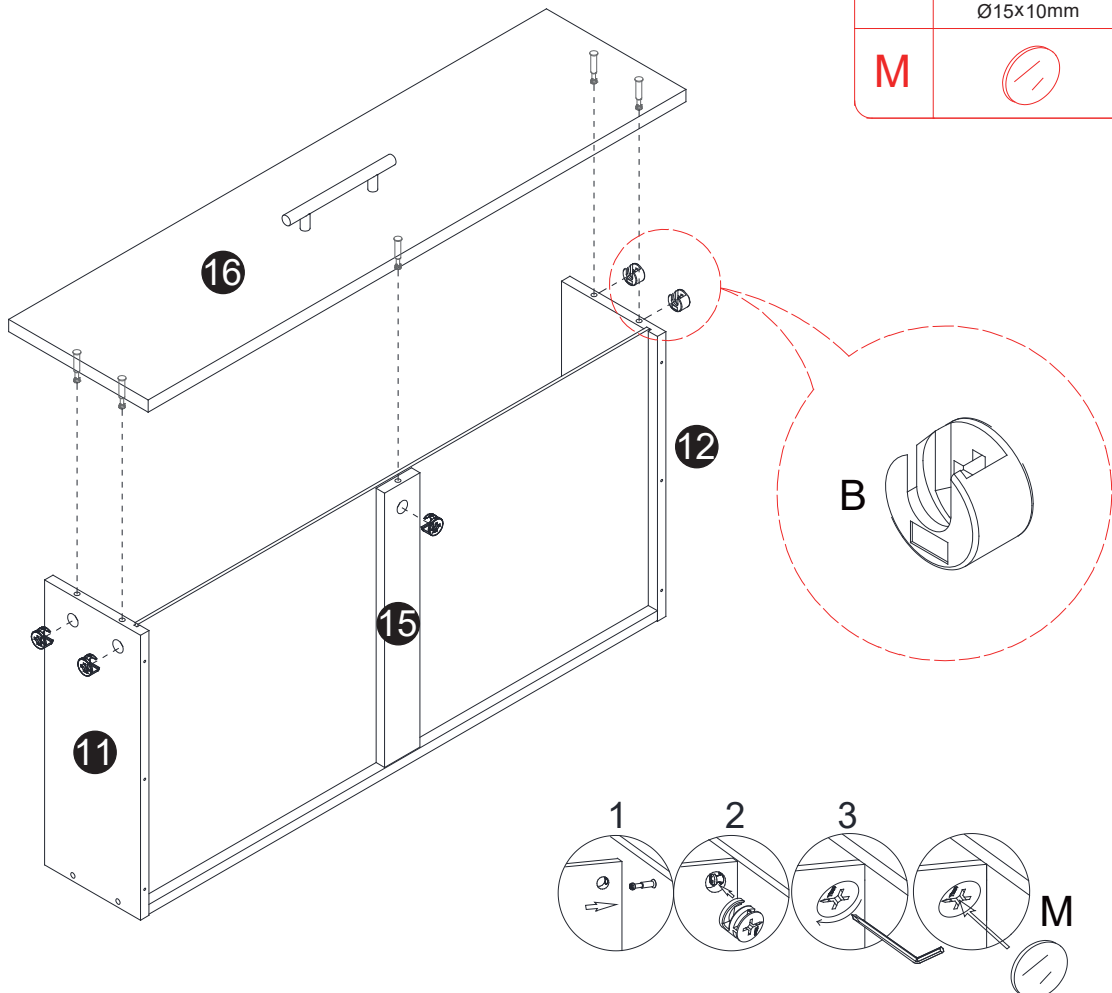

x2

Step 15

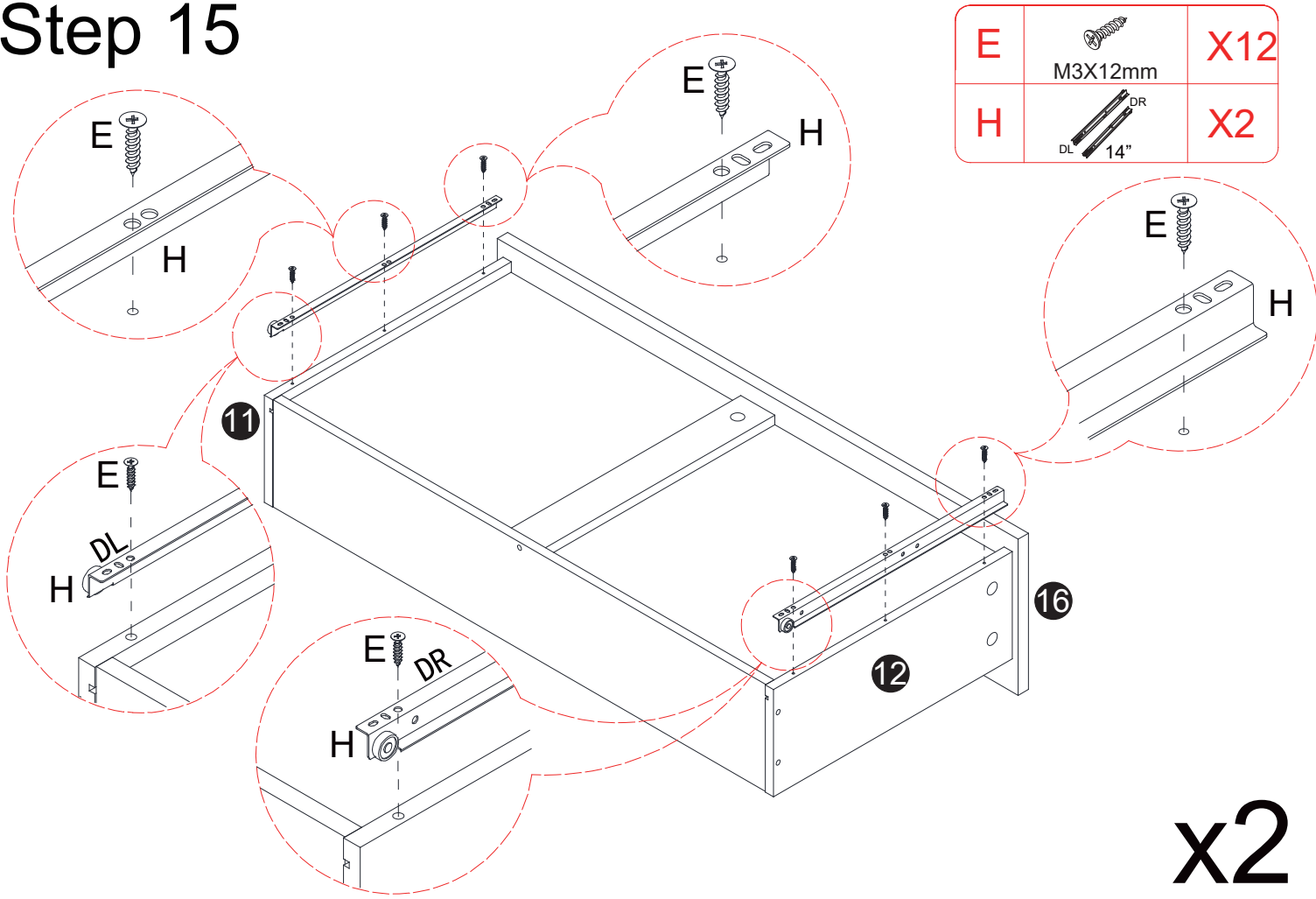

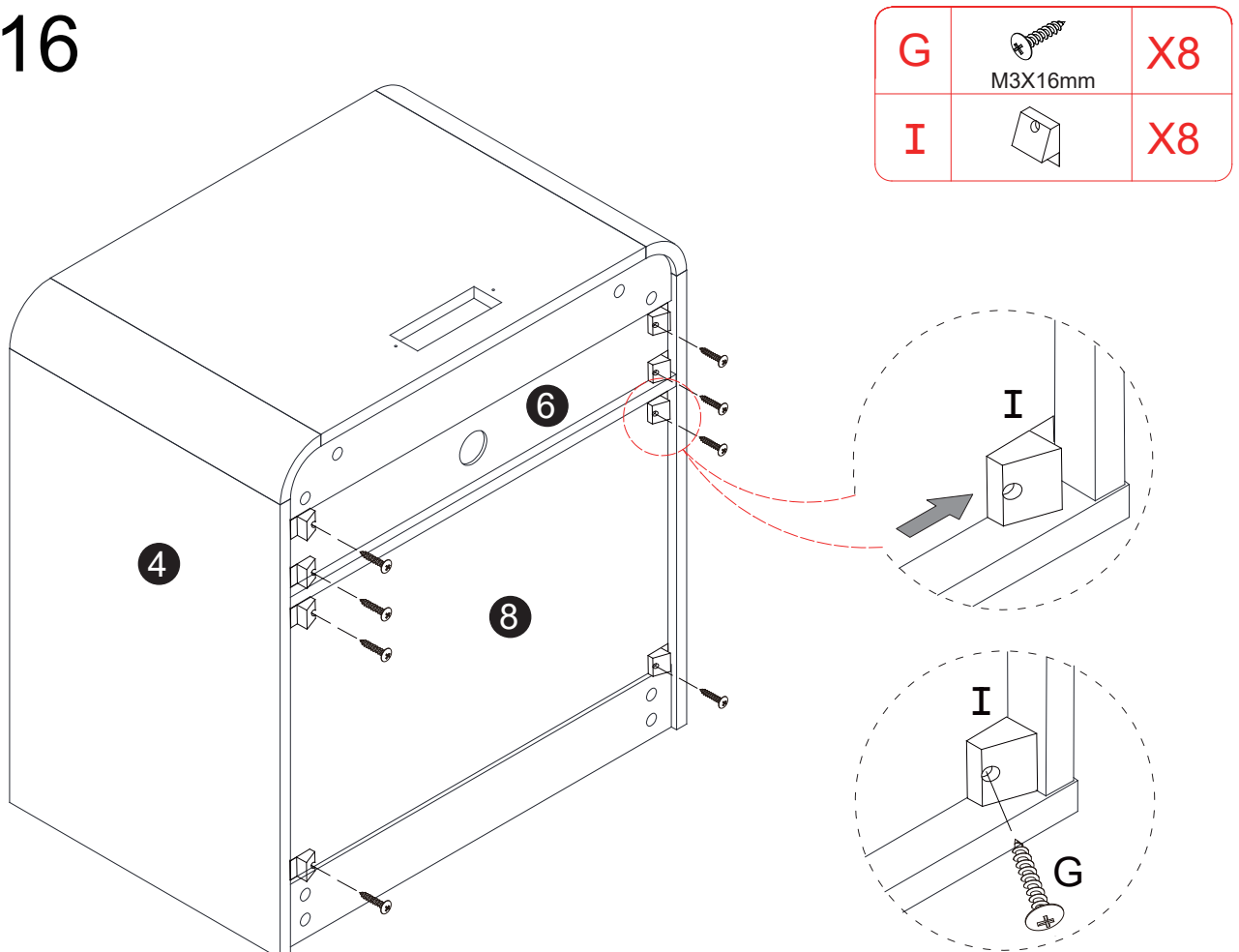

x2

Step 16



Step 17

E	 M3X12mm	X2
K		X1

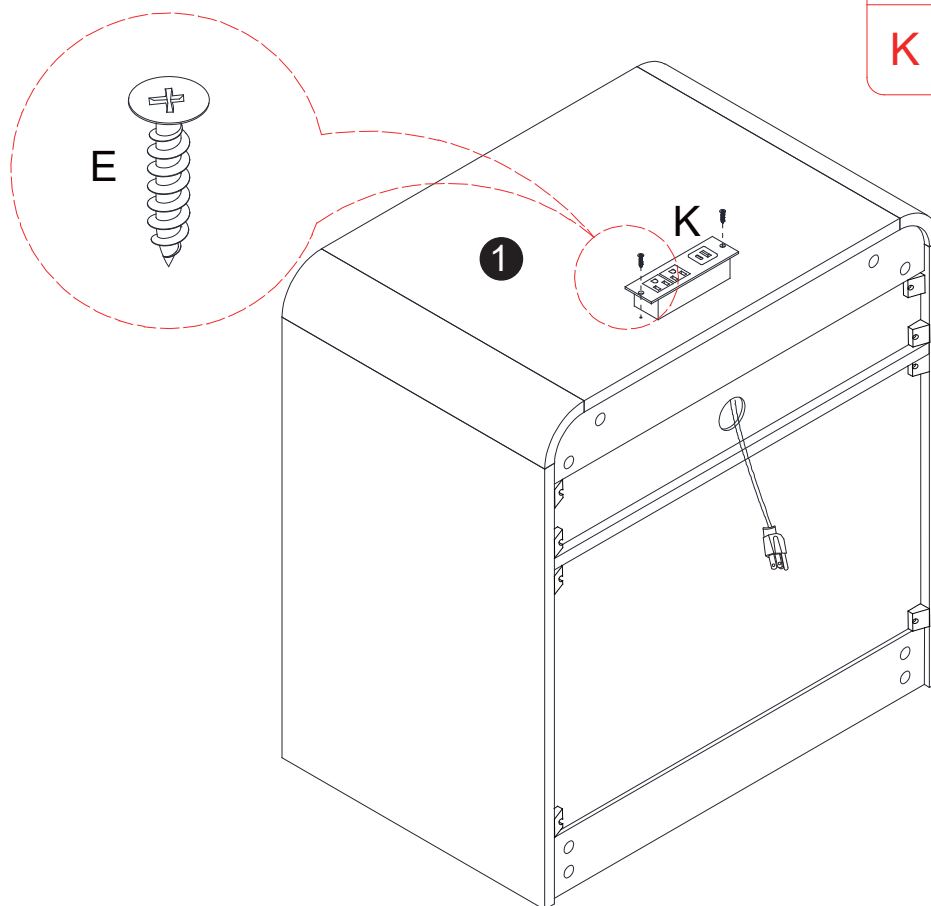

Step 18

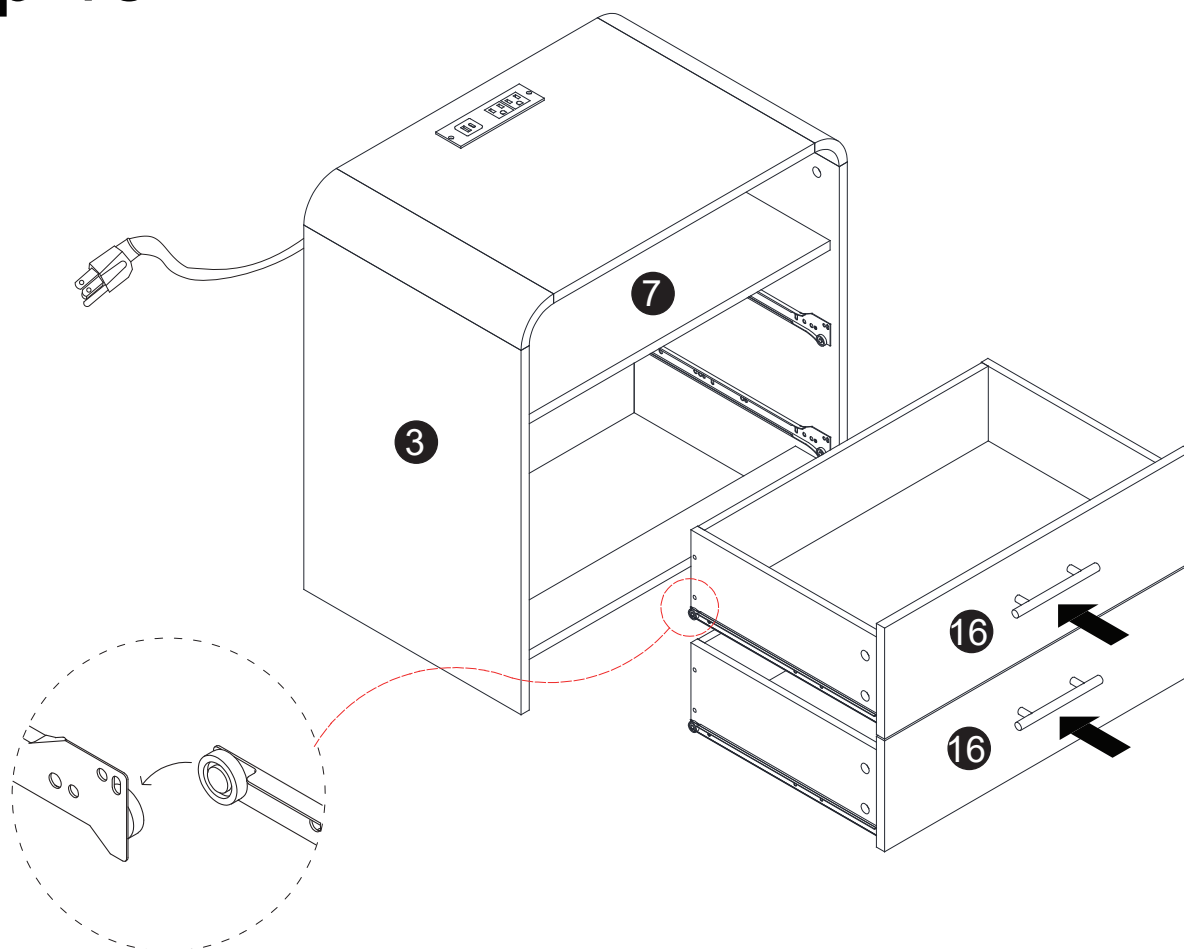

Step 19

