

TUSCANY BROWN : BRUN TOSCANE : *PARDO TOSCANA*

DARK CHOCOLATE : CHOCOLAT NOIR : *CHOCOLATE NEGRO*

CAPPUCCINO CHERRY : CERISIER CAPPUCCINO : *CEREZO CAPPUCCINO*



CODE / CÓDIGO	QTY / QTÉ / CANT.	CODE / CÓDIGO	QTY / QTÉ / CANT.	CODE / CÓDIGO	QTY / QTÉ / CANT.	CODE / CÓDIGO	QTY / QTÉ / CANT.
HC20B	1	40	1	61	2	80	2
HC21B	1	41	1	70	1	71	1
30	1	60	2	BB81C	4	99	1
31	1						



two people are required to assemble and move this model.
deux personnes sont requises pour assembler et déplacer ce modèle.
se necesitan dos personas para ensamblar y desplazar este mueble.

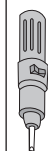







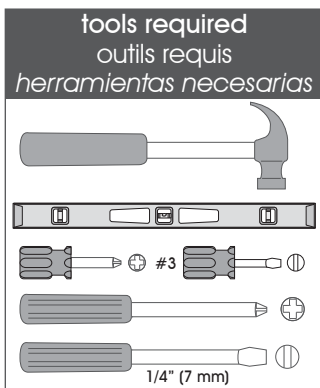
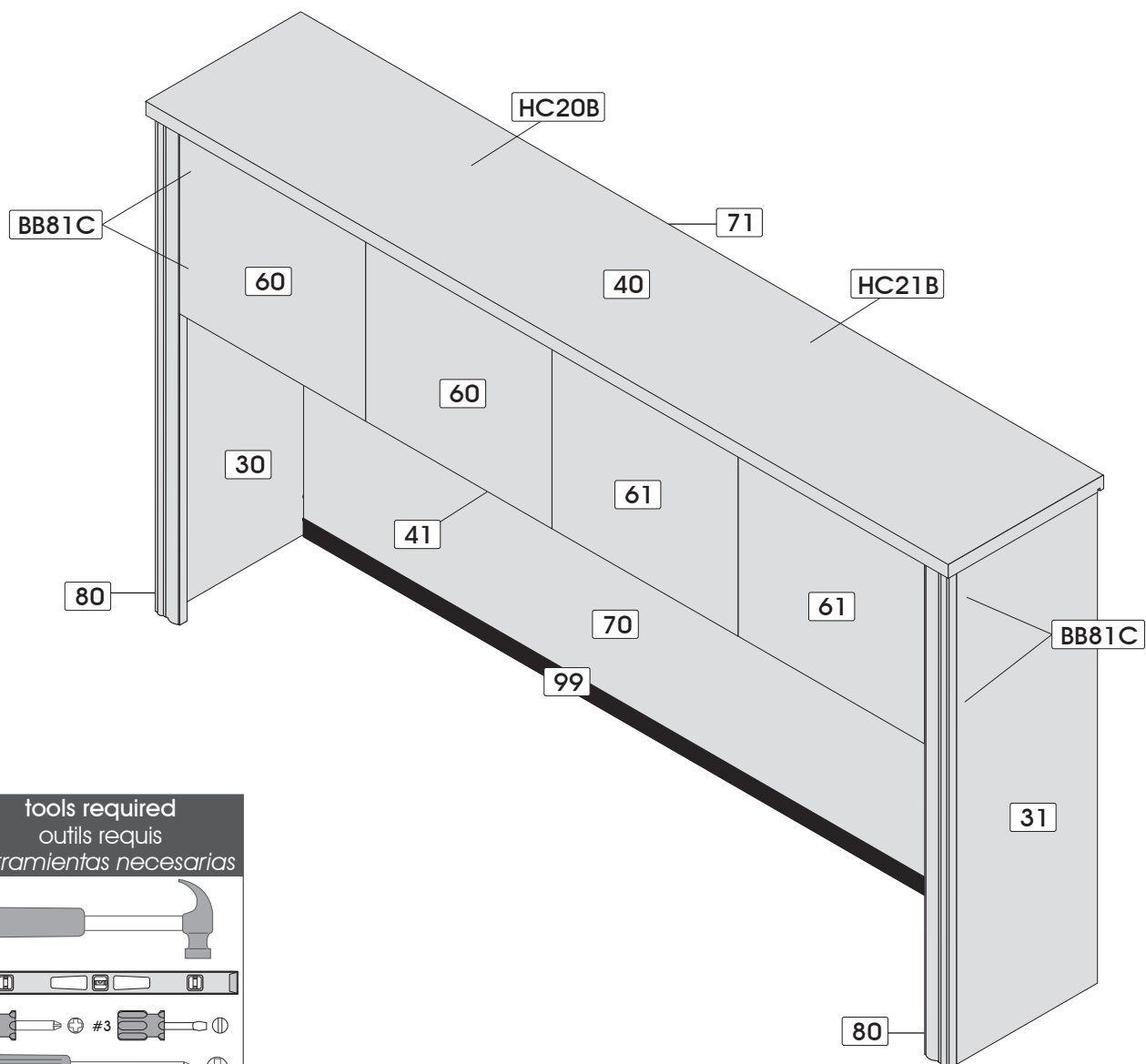

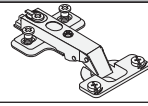

the use of electric tools must be made with vigilance.

l'utilisation d'outils électriques doit être faite avec vigilance.

las herramientas eléctricas deben utilizarse con sumo cuidado.

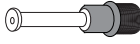
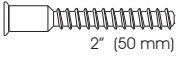

CODE / CÓDIGO	QTY / QTÉ / CANT.	CODE / CÓDIGO	QTY / QTÉ / CANT.	CODE / CÓDIGO	QTY / QTÉ / CANT.	CODE / CÓDIGO	QTY / QTÉ / CANT.
AM-181	 3/16" (5 mm) 2	CH-838	 4	GO-796	 8	RU-420	 2
AM-182	 1/16" (2 mm) 2	CH-840	 4	H-03	 20	TI-552	 1
CA-99	 20	CL-140	 11	H-36	 20	VC-204	 2" (50 mm) 4
CA-100	 4			PF-106	 1		

REAL SIZE / GRANDEUR RÉELLE / TAMAÑO REAL

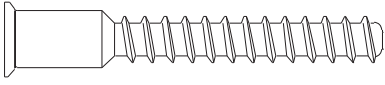
CODE / CÓDIGO	QTY / QTÉ / CANT.
VC-204	 2" (50 mm) 4

IMPORTANT NOTICE / NOTE IMPORTANTE / NOTA IMPORTANTE

Group together all the hardware required for each step as the construction of your piece of furniture is progressing.
 Regroupez toutes les quincailleries requises pour chaque étape de façon à vous assurer de tout installer au bon moment.
 Reúna todas las quincallas necesarias para cada una de las etapas de montaje, para asegurar una correcta instalación en el momento adecuado.

▶ IMPORTANT NOTICE / NOTE IMPORTANTE / NOTA IMPORTANTE

Duly complete the self-adhesive sticker. / Assurez-vous de bien remplir l'autocollant. / Asegúrese de completar correctamente la etiqueta.

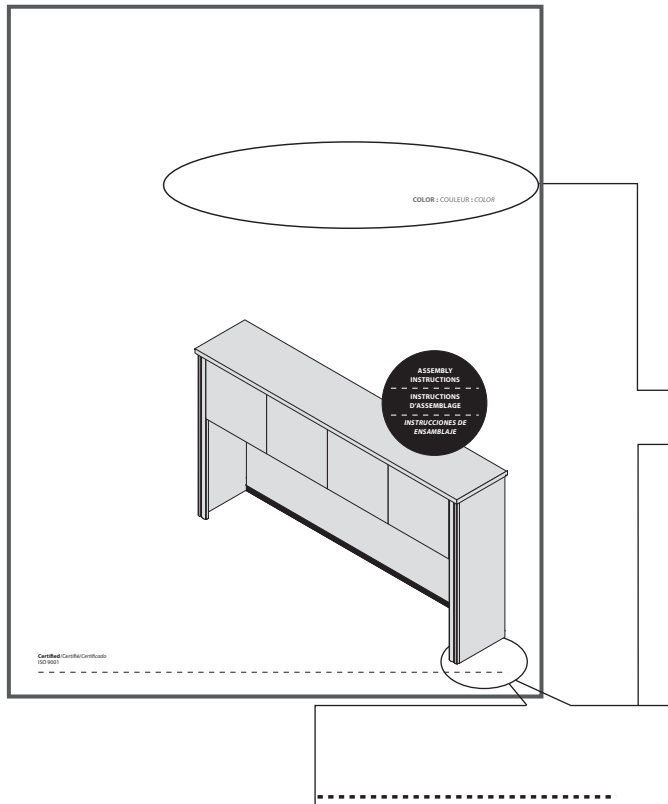

To better serve you!
Pour mieux vous servir!

Model / Modèle: _____

Production Number
Numéro de production: _____

Customer Service
Service à la clientèle

Important/Importante

Please retain the self-adhesive sticker which you will find at step 13 of the instruction manual.

Conservez l'autocollant qui sera collé seulement à l'étape 13 du feuillet d'instructions.

Conserve la etiqueta que será pegada sólo en la etapa 13 de la hoja de instrucciones.

▶ IMPORTANT NOTICE / NOTE IMPORTANTE / NOTA IMPORTANTE

Main hardware system / Système de quincaillerie principal / Sistema principal de quincalla

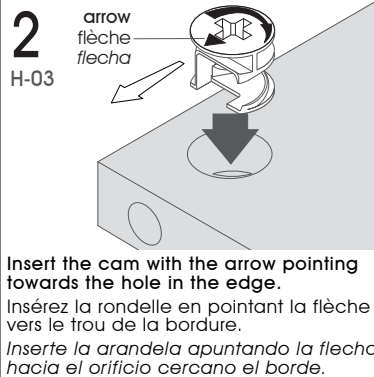
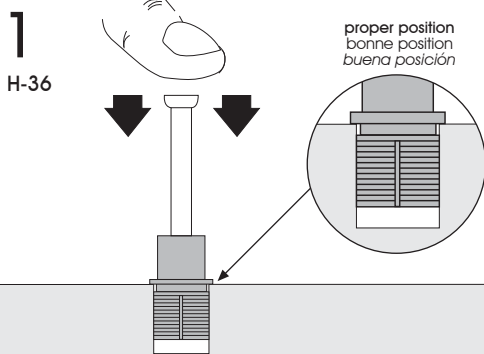

If needed / En cas de nécessité
En caso de necesidad

How to remove a misplaced assembly bolt (H-36).
Comment retirer un boulon (H-36) mal situé.
Cómo retirar un perno (H-36) mal ubicado.

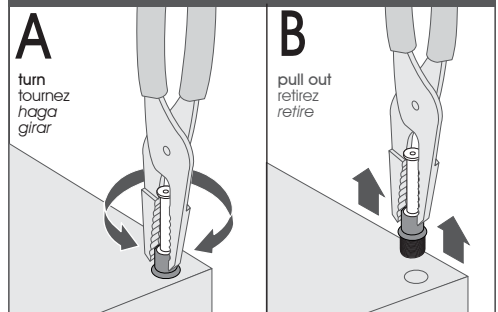

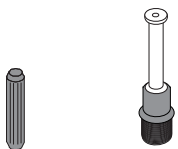
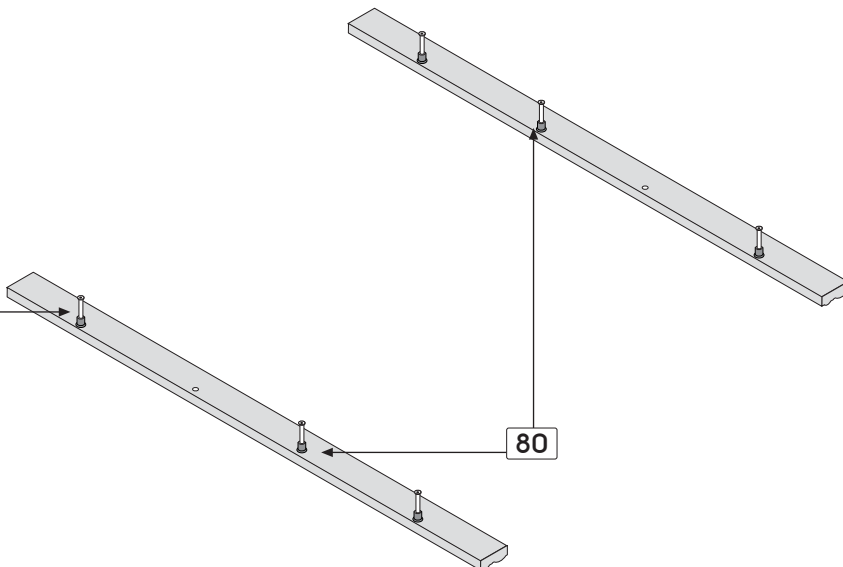
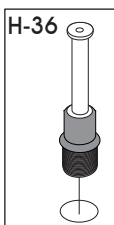
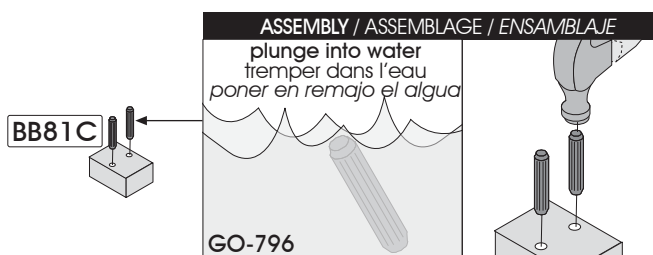
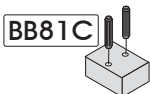
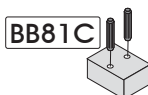
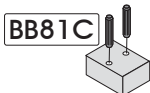

Code / Código
Qty / Qté / Cant.

GO-796
x 8

H-36
x 6

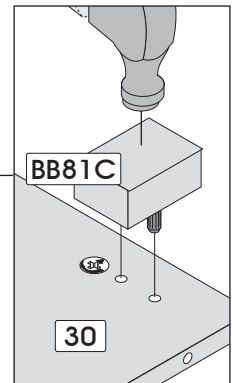
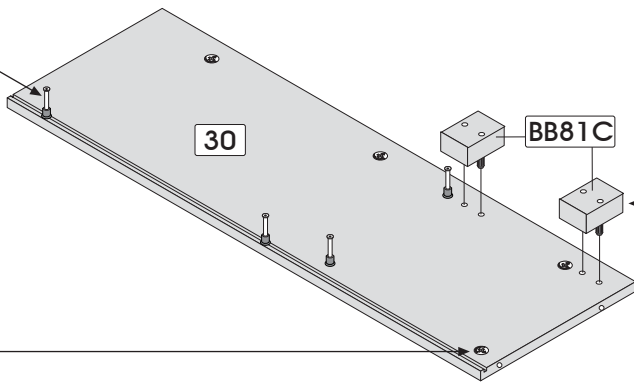
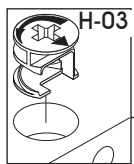
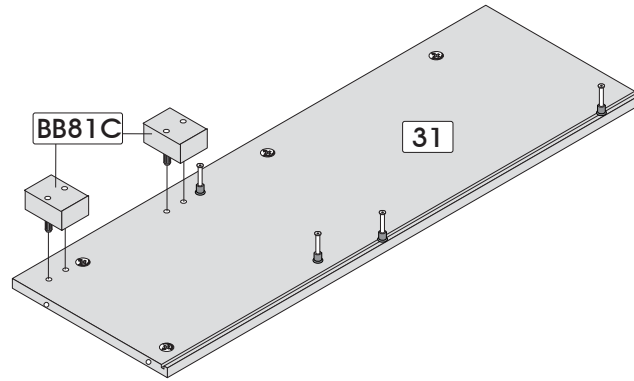
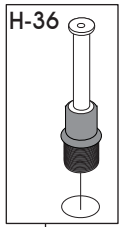

Code / Código
Qty / Qté / Cant.



H-03
x 8

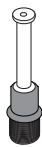

H-36
x 8

Assembling sequence
 Séquence d'assemblage
 Secuencia de ensamblaje
 Parts / Pièces / Piezas:

31 + 80

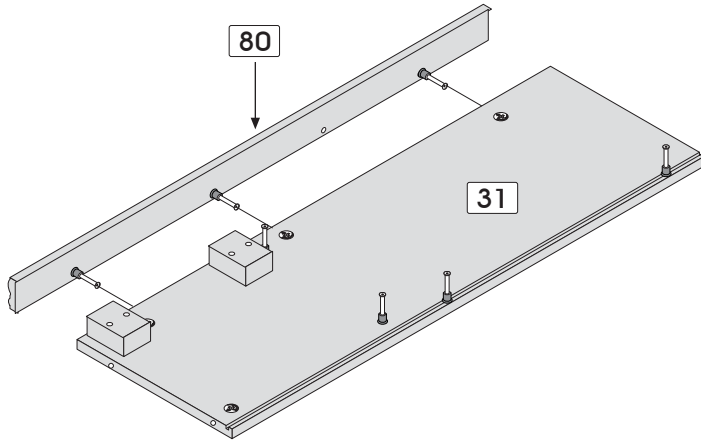



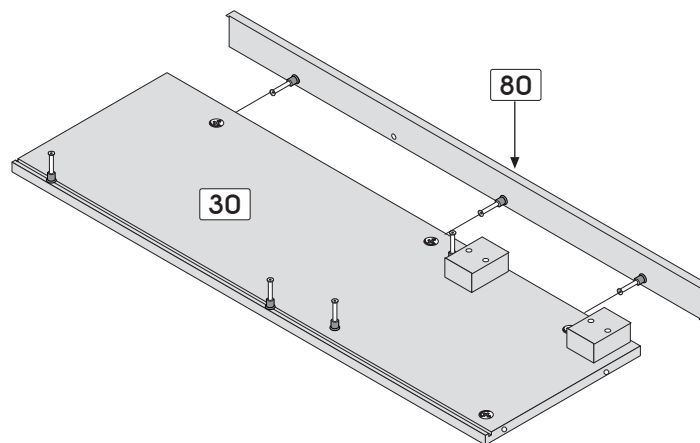

Assembling sequence
 Séquence d'assemblage
 Secuencia de ensamblaje
 Parts / Pièces / Piezas:

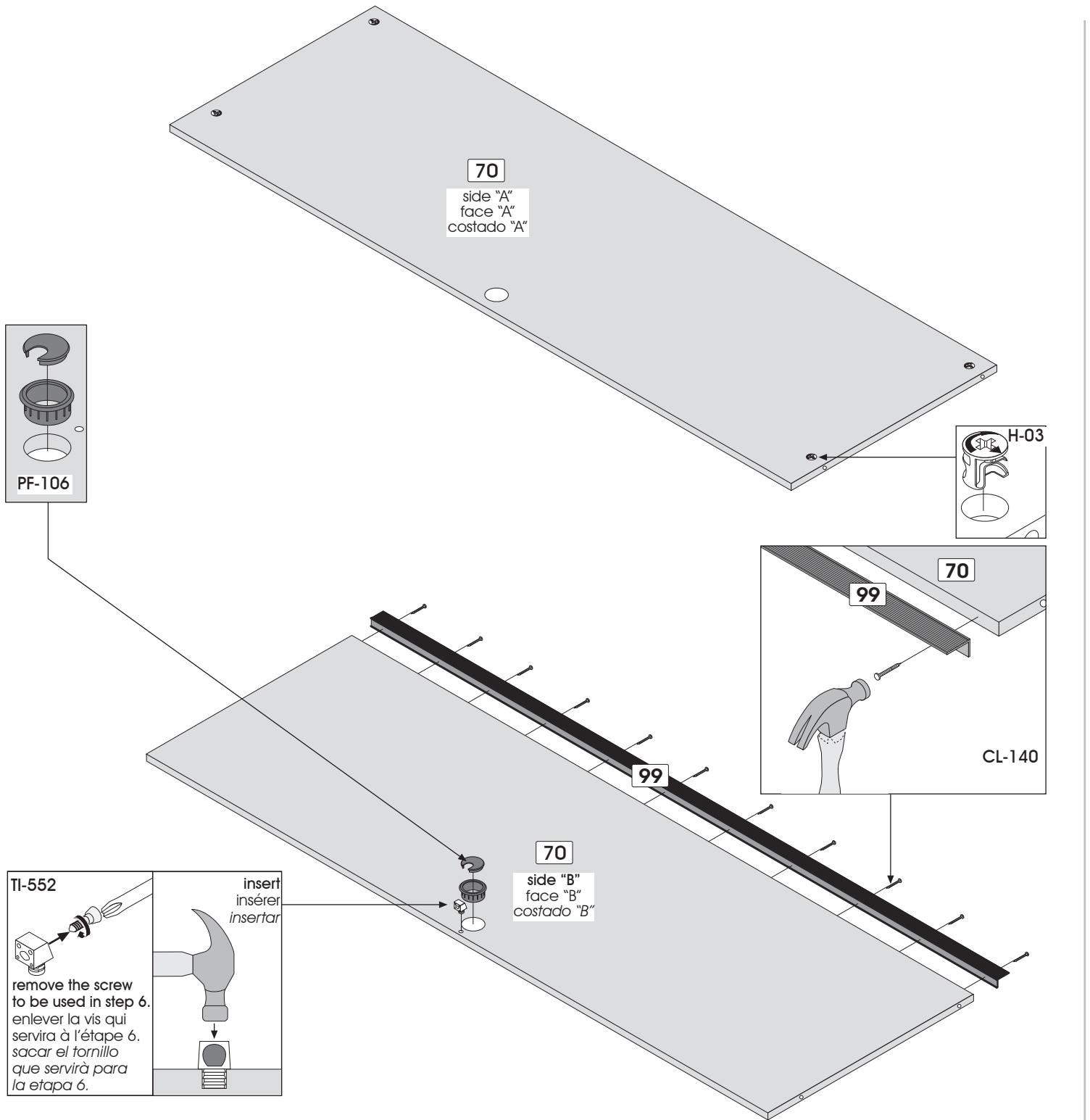
30 + 80





				
Code / Código	H-03	TI-552	PF-106	CL-140
Qty / Qté / Cant.	x 4	x 1	x 1	x 11

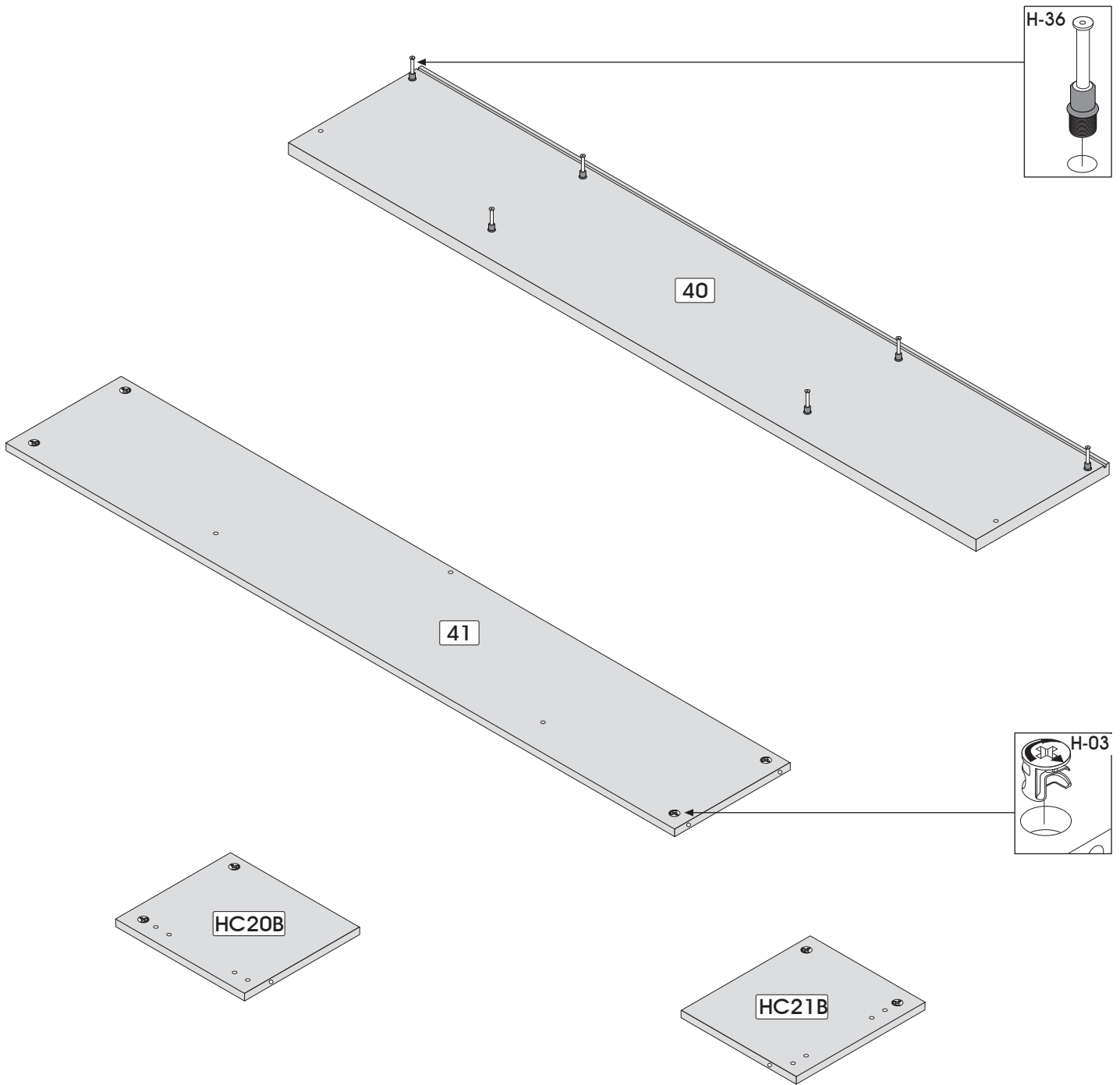

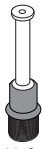
		
Code / Código	H-03	H-36
Qty / Qté / Cant.	x 8	x 6

IMPORTANT NOTICE / NOTE IMPORTANTE / NOTA IMPORTANTE

▶ Main hardware system / Système de quincaillerie principal / Sistema principal de quincalla

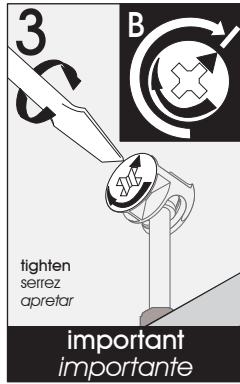
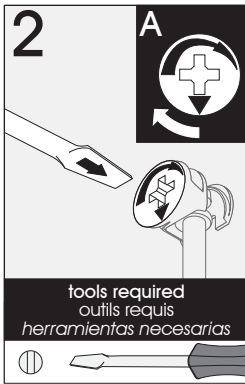
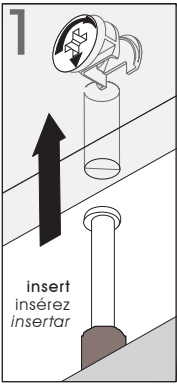

Make sure to properly tighten each cam to ensure furniture solidity. Otherwise, parts could be damaged or the user could be injured.

Assurez-vous de bien resserrer chaque rondelle pour assurer la solidité du meuble. Dans le cas contraire, des pièces pourraient être endommagées ou l'utilisateur pourrait se blesser.

Asegúrese de apretar bien cada arandela para garantizar la solidez del mueble. De lo contrario, podría provocarse daño a las piezas o las personas.

6

PRE-ASSEMBLY / PRÉ-ASSEMBLAGE / PREENSAMBLAJE

HUTCH FOR CREDENZA / ÉTAGÈRE POUR CRÉDENCE / ESTANTERÍA PARA CREDENCIA

ASSEMBLING SEQUENCE
SÉQUENCE D'ASSEMBLAGE
SECUENCIA DE ENSAMBLAJE

Parts / Pièces / Piezas:

41 HC20B HC21B

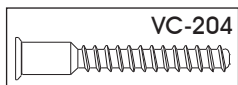
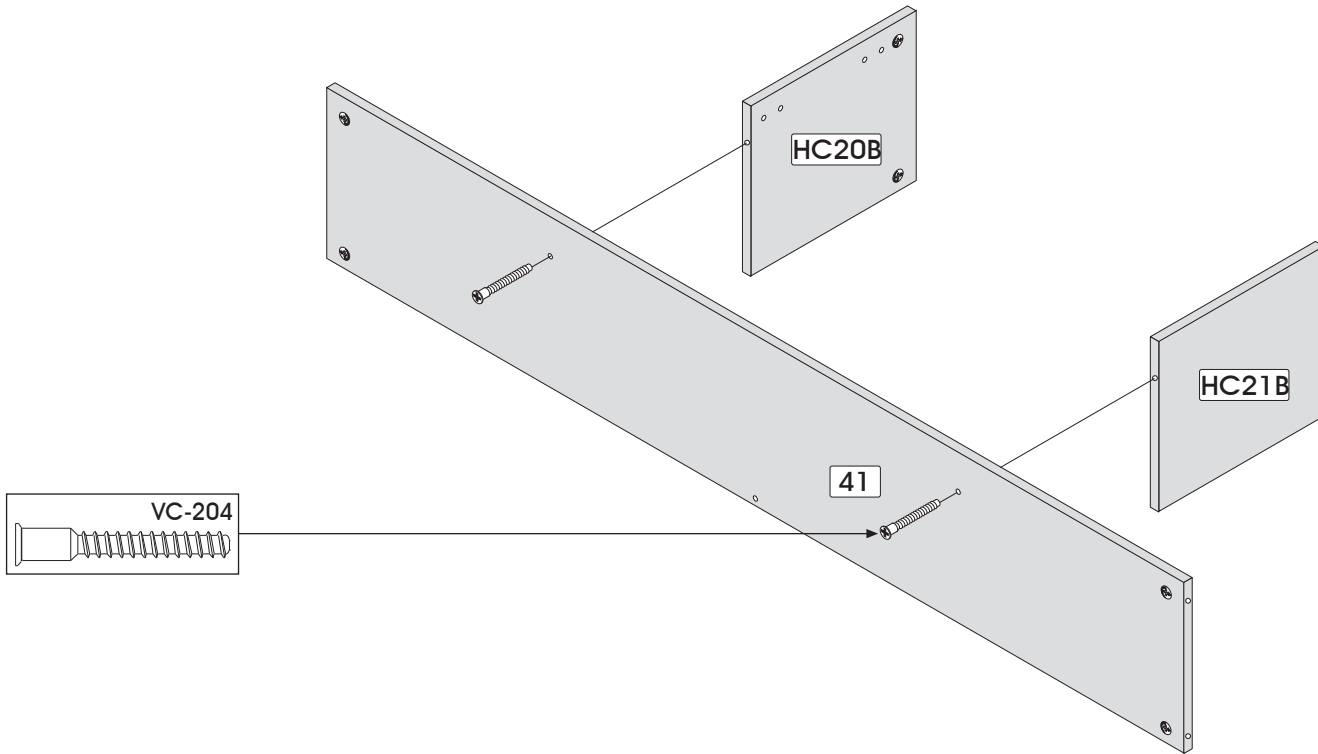

6

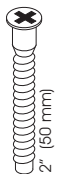

Code / Código VC-204
Qty / Qté / Cant. x 2

ASSEMBLE UPSIDE DOWN
 ASSEMBLEZ EN POSITION RENVERSÉE
 REALICE EL ENSAMBLAJE EN POSICIÓN INVERTIDA

ASSEMBLING SEQUENCE
 SÉQUENCE D'ASSEMBLAGE
 SECUENCIA DE ENSAMBLAJE

Parts / Pièces / Piezas:

30 41 70 31

Important/Importante

RU-420



Remove paper on one side only of RU-420.
 Retirez le papier sur seulement une des faces du RU-420.
 Retire el papel de sólo uno de los costados del RU-420.

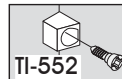
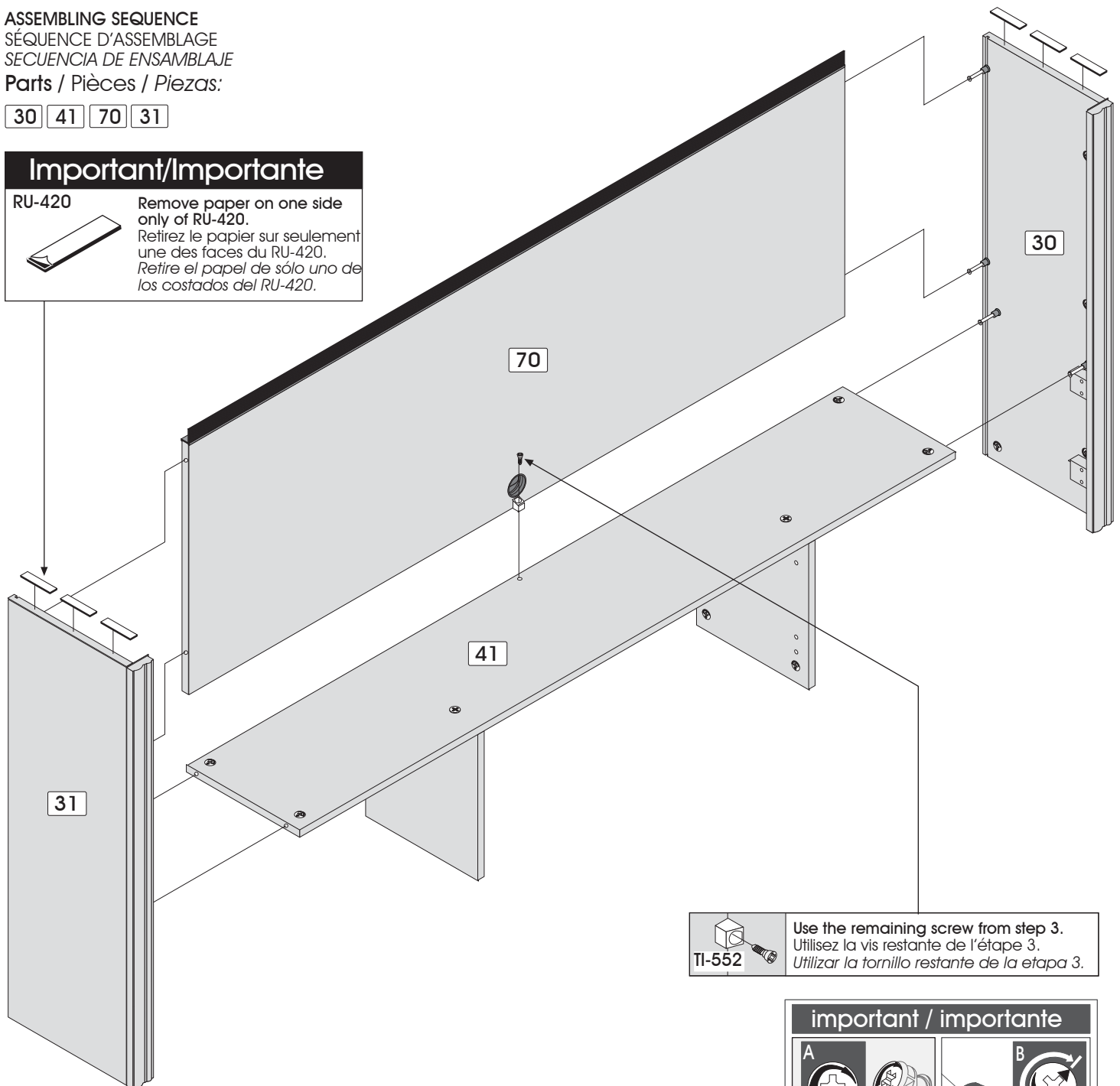

Use the remaining screw from step 3.
 Utilisez la vis restante de l'étape 3.
 Utilizar la tornillo restante de la etapa 3.

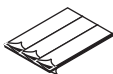

Code / Código

RU-420

Qty / Qté / Cant.

x 2



two people are required to assemble and move this model.
 deux personnes sont requises pour assembler et déplacer ce modèle.
 se necesitan dos personas para ensamblar y desplazar este mueble.

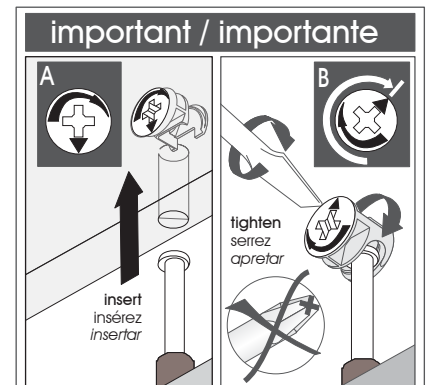

ASSEMBLING SEQUENCE
SÉQUENCE D'ASSEMBLAGE
SECUENCIA DE ENSAMBLAJE

Parts / Pièces / Piezas:

30 HC20B HC21B 31 + 71 + 40

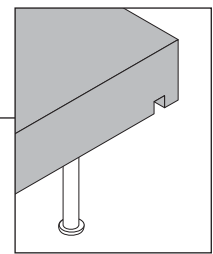
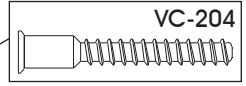
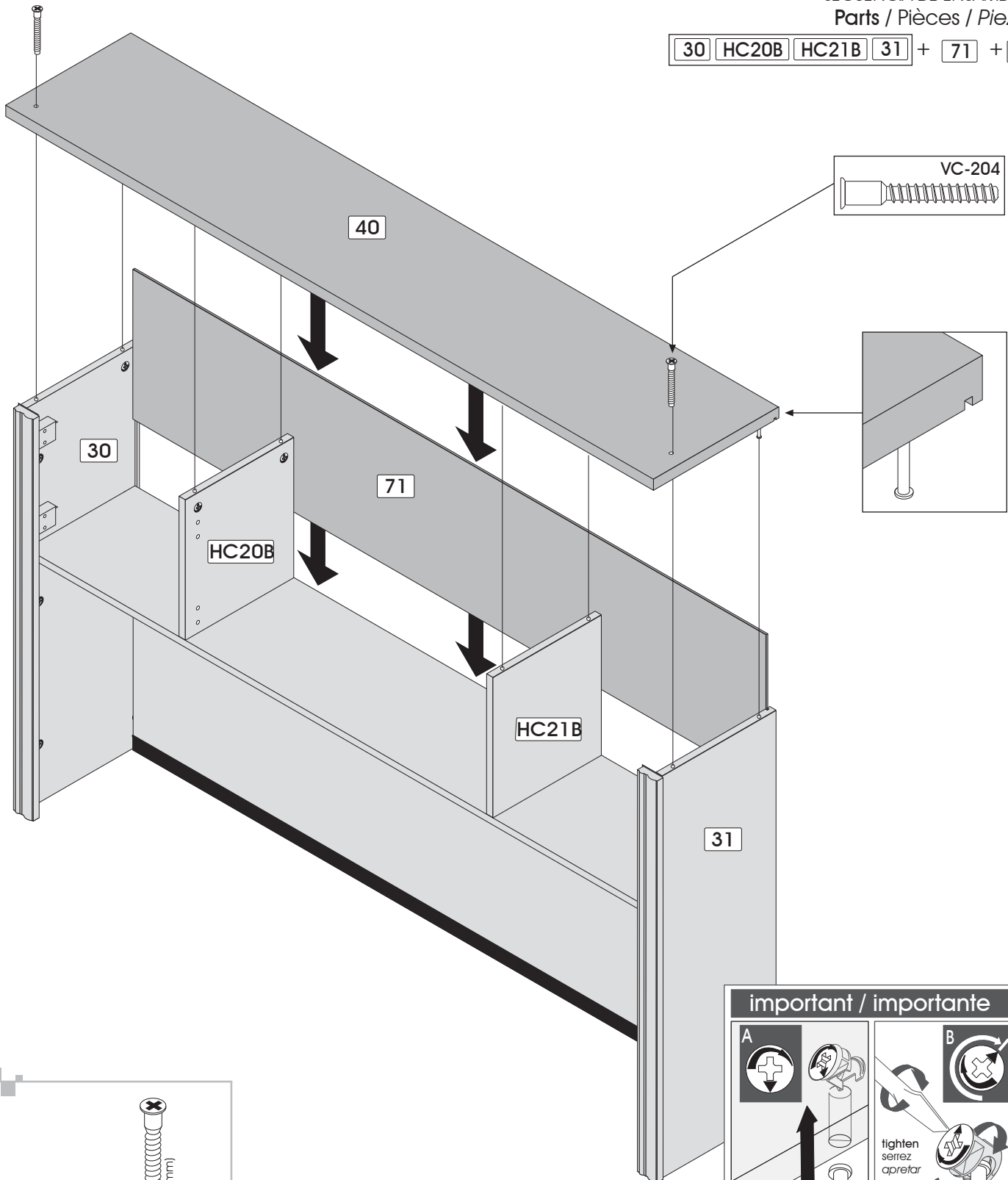

important / importante

<p>A</p> <p>insert insérez insertar</p>	<p>B</p> <p>tighten serrez apretar</p>
--	---

8

Code / Código VC-204
Qty / Qté / Cant. x 2

Important/Importante

If you have the pedestal 60620 (not included), assemble it before installing the hutch.

Si vous possédez un caisson 60620 (non-inclus) veuillez débiter son assemblage avant d'installer l'étagère.

Si posee el módulo 60620 (no se incluye), ármela primero antes de instalar la estantería.



two people are required to assemble and move this model.
deux personnes sont requises pour assembler et déplacer ce modèle.
se necesitan dos personas para ensamblar y desplazar este mueble.

2 possibilities / 2 possibilités / 2 posibilidad

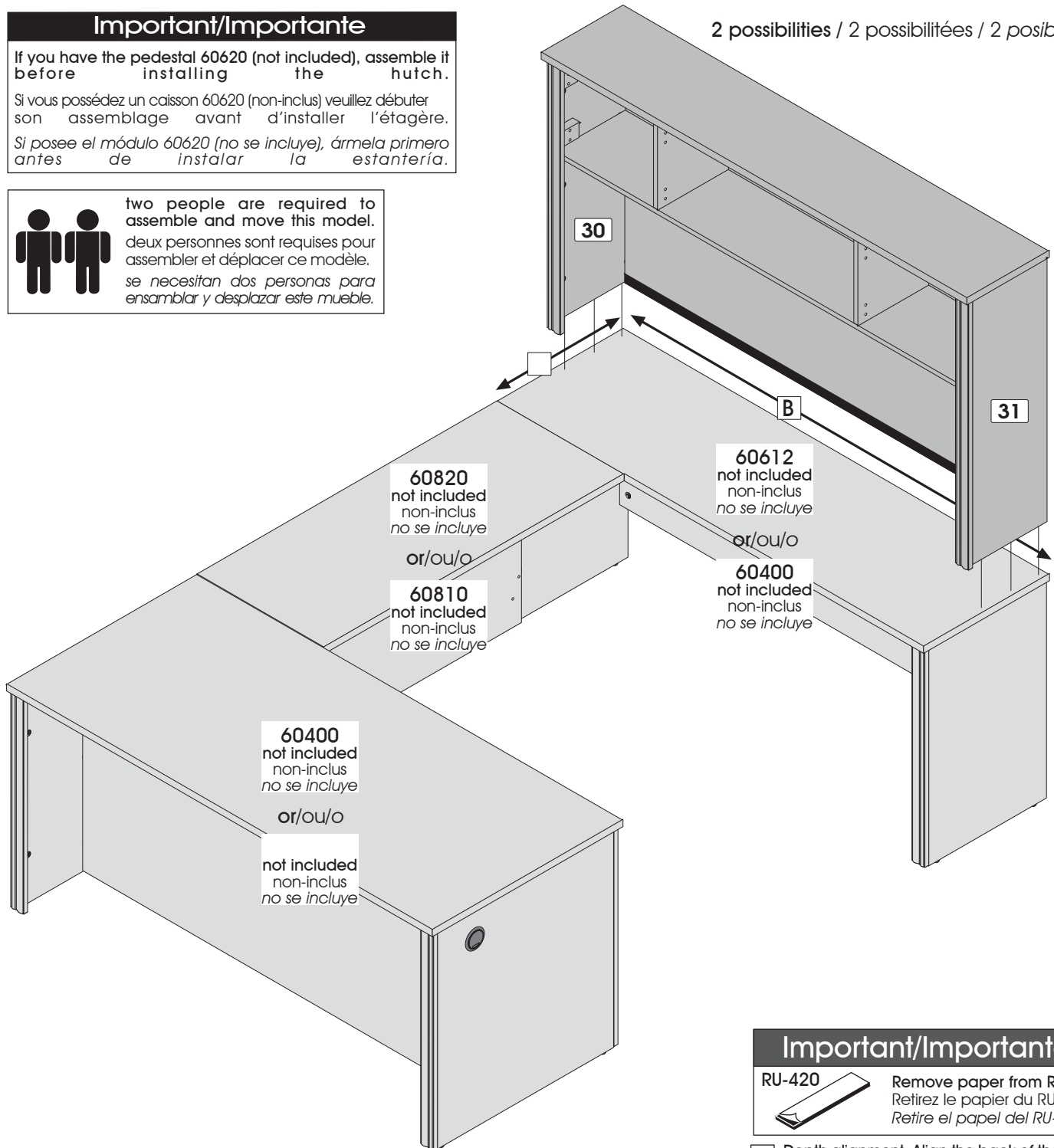
**Important/Importante**

RU-420



Remove paper from RU-420.
Retirez le papier du RU-420.
Retire el papel del RU-420.

- A** Depth alignment: Align the back of the hutch with the back of the 60612 or 60400.
Alignement en profondeur : Aligner l'arrière de l'étagère avec l'arrière de 60612 ou 60400.
Alineamiento en profundidad : Alinear la parte posterior de la estantería con la parte posterior del 60612 u 60400.
- B** Width alignment: Align side panels 30 and 31 of the hutch with side panels 60612 or 60400.
Alignement en largeur : Aligner les côtés 30 et 31 avec les côtés de 60612 ou 60400.
Alineamiento de ancho : Alinear los costados 30 y 31 con los costados del 60612 u 60400.

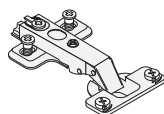
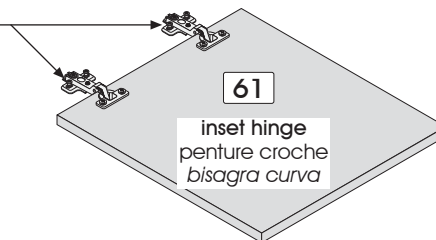
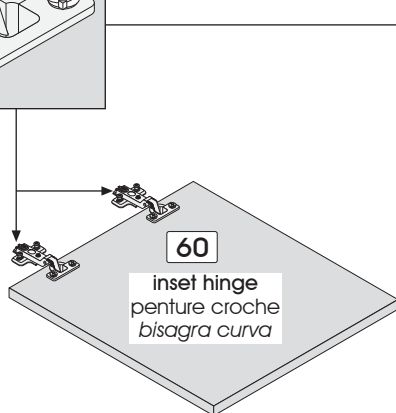
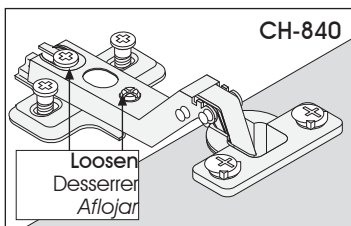
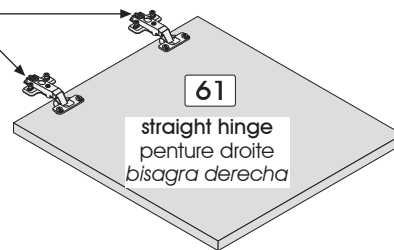
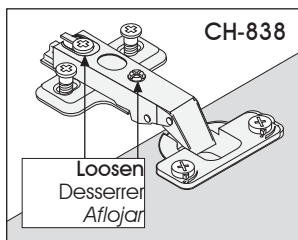
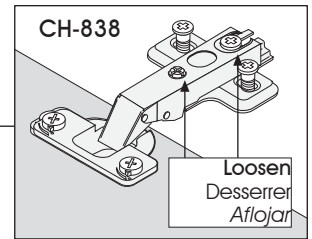
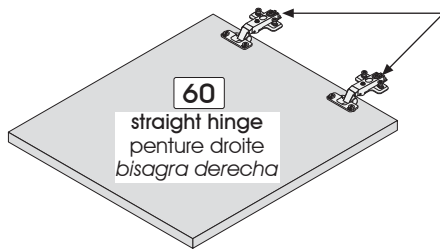

CH-838

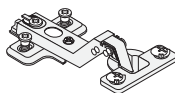

CH-840

Code / Código
Qty / Qté / Cant.

x 4

x 4

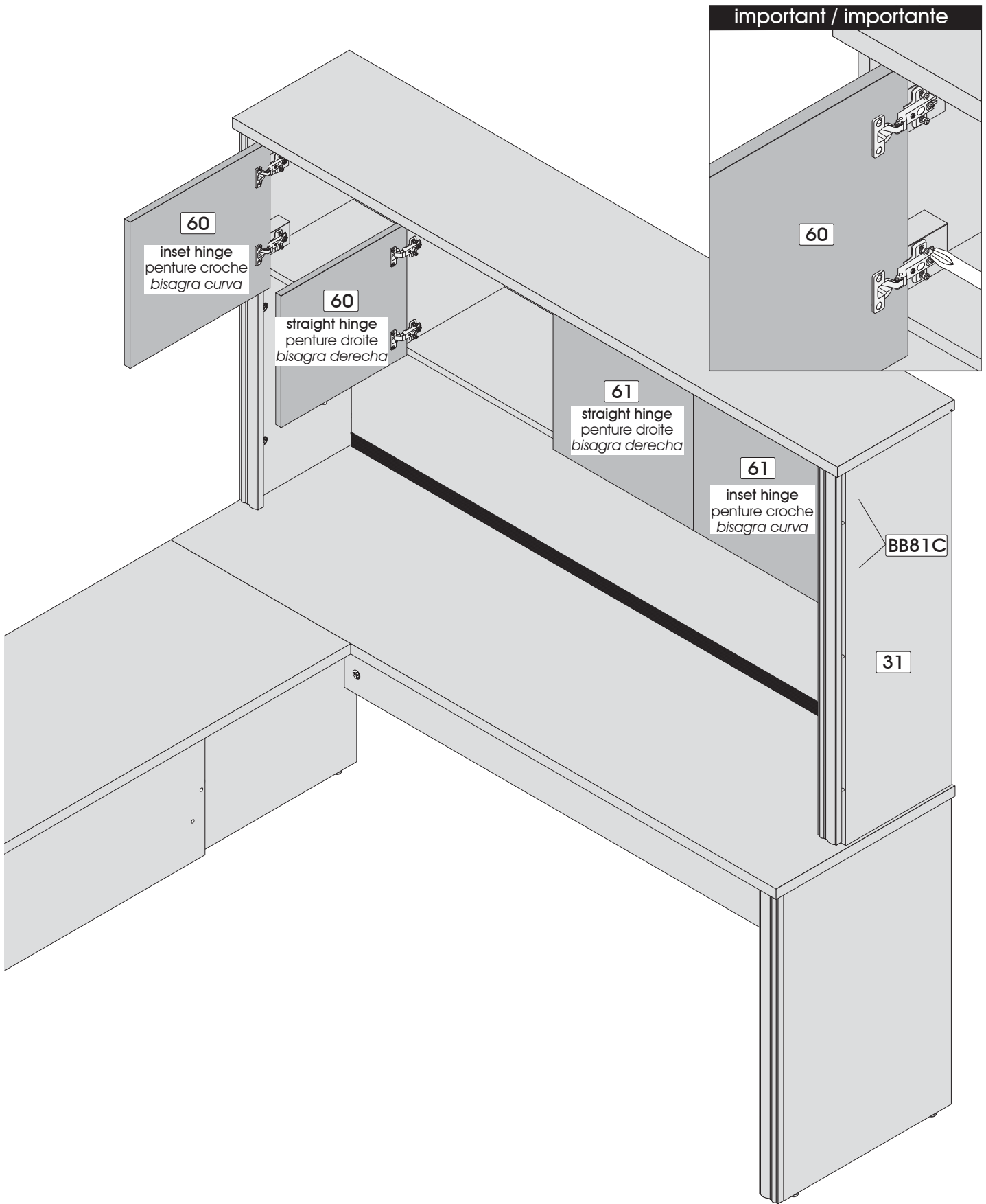

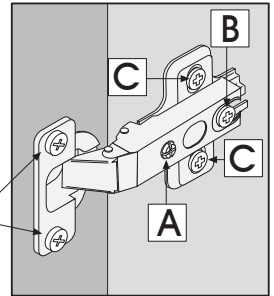

Use screw A for horizontal adjustment, screw B for depth adjustment and screws C for vertical adjustment.
 Utilisez la vis A pour l'ajustement horizontal, les vis B pour l'ajustement en profondeur et les vis C pour l'ajustement vertical.

Utilice el tornillo A para realizar el ajuste horizontal, los tornillos B para el ajuste de profundidad y los tornillos C para el ajuste vertical.

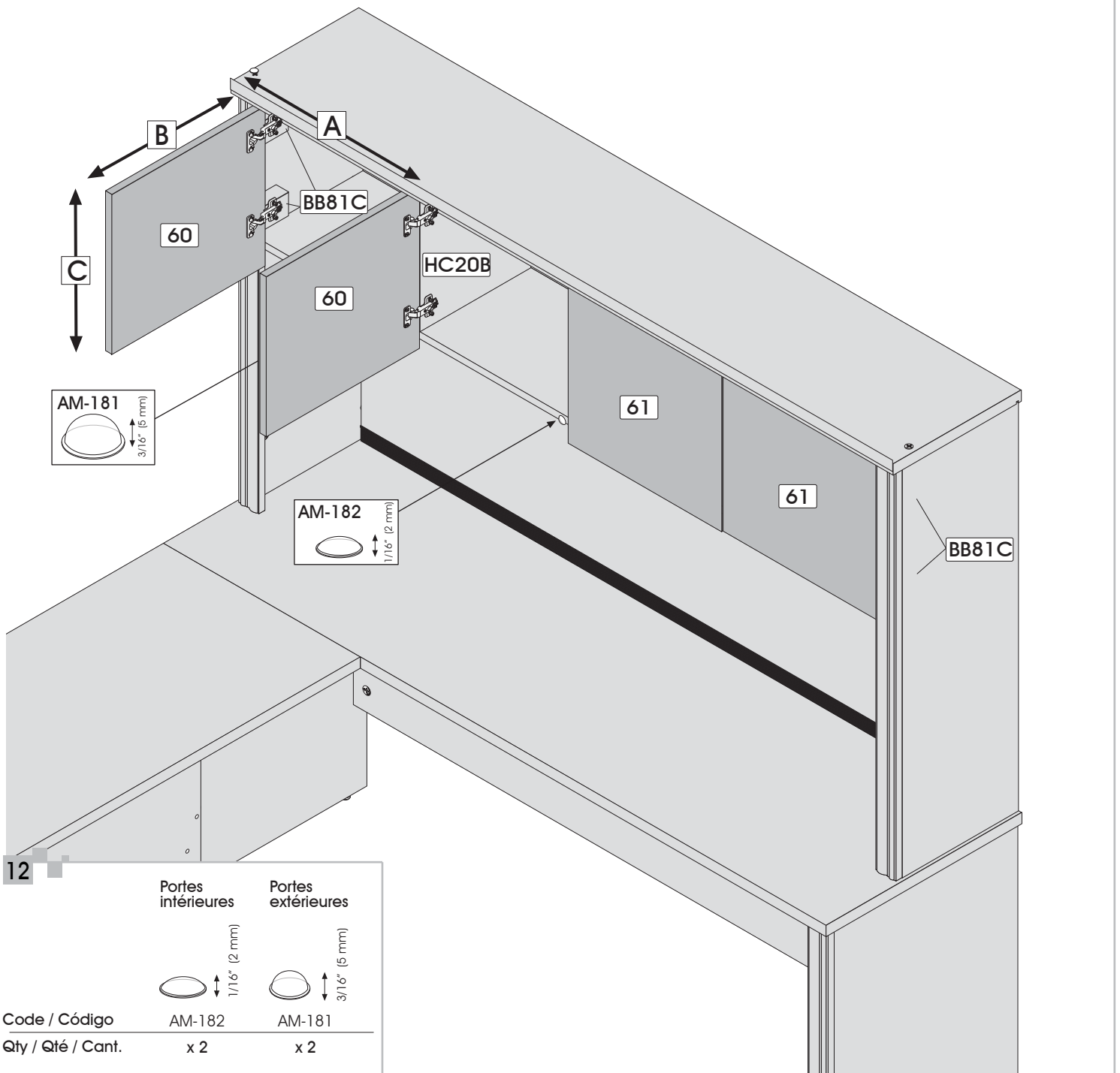

To remove hinges, start by loosening these two screws to free the locking system.
 Pour enlever les pentures, desserrez ces deux vis d'abord pour libérer le système de verrouillage.
 Para retirar las bisagras, afloje primero estos dos tornillos para liberar el sistema de fijación.



	Portes intérieures	Portes extérieures
	 1/16" (2 mm)	 3/16" (5 mm)
Code / Código	AM-182	AM-181
Qty / Qté / Cant.	x 2	x 2

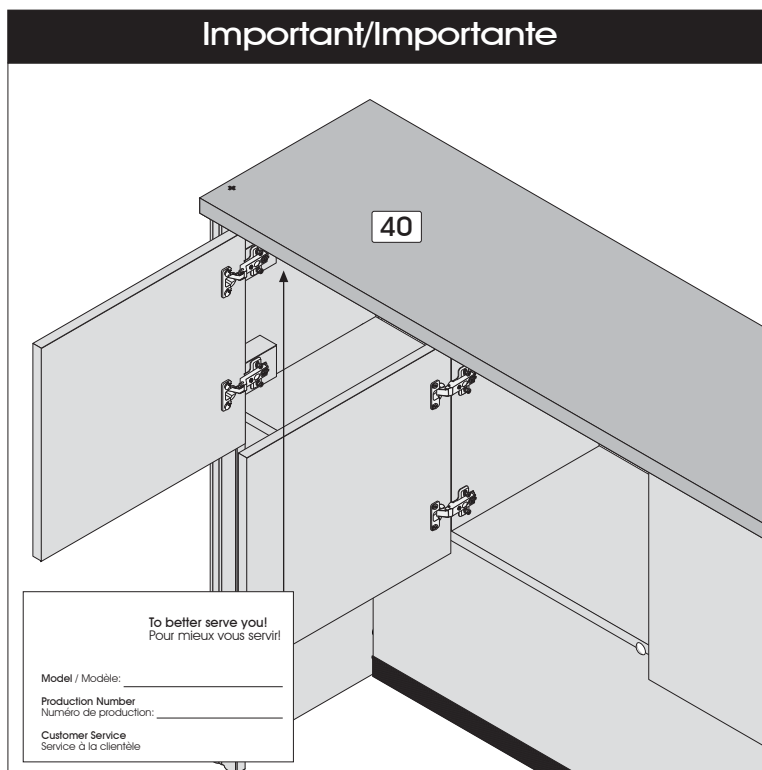

For future reference and to better serve you, please complete and apply the self-adhesive sticker in an accessible space such as under part 40.

Pour mieux vous servir en cas de besoin, veuillez compléter et apposer l'autocollant dans un endroit facilement accessible tel que le dessous de la pièce 40.

Para uno mejor servicio en caso de necesidad, poner la etiqueta en un lugar de fácil acceso como por ejemplo la parte inferior de la pieza 40.

Note/ Note / Nota

When you have completed the assembly of your new furniture, install plastic caps
Lorsque vous avez complété l'assemblage de votre meuble, installez les capuchons de plastique
Una vez que haya completado el ensamblaje del mueble, coloque los capuchones de plástico

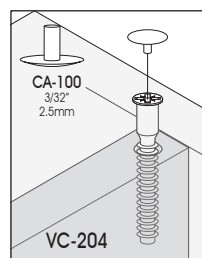
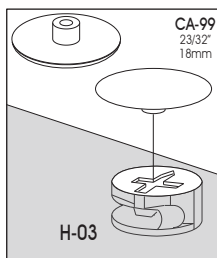

Product care / Entretien du produit / Mantenimiento del producto

Avoid placing the furniture in the sunlight or near a source of heat. Use a soft dry cloth for dusting. To clean heavy dirt, use a cloth dipped in a solution of mild detergent and water. Avoid leaving wet objects on the surface or using commercial chemical cleaning products.

Évitez d'exposer le meuble au soleil ou près de toute source de chaleur. Pour le nettoyage, utilisez un chiffon doux et sec. Pour la grosse saleté, utilisez un chiffon humidifié avec un peu de détergent dilué dans l'eau. Évitez de laisser des objets mouillés sur la surface de votre meuble ou d'utiliser des nettoyants chimiques.

Evite exponer el mueble al sol o las fuentes de calor. Para limpiarlo, utilice un paño suave y seco. Para limpiar las manchas rebeldes, utilice un trapo húmedo con un poco de detergente diluido en agua. No deje objetos mojados encima del mueble ni utilice limpiadores que contengan productos químicos.

Congratulations! You are now the owner of a quality product
Félicitations! Vous avez maintenant en votre possession un produit de qualité
Felicitaciones! Ahora es usted dueño de un producto de calidad.

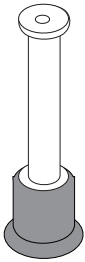

You are at a step of hardware installation and some H-36 are missing:
Before calling to order your missing bolts (H-36), please make sure you have not installed any bolts (H-36) in the wrong place. To remove a bolt (H-36) which is not in the correct place, please refer to your instruction manual.

Vous êtes à une étape d'installation de quincaillerie et il vous manque des H-36 :
Avant d'appeler pour commander des boulons (H-36), assurez-vous de ne pas avoir installé des boulons (H-36) au mauvais endroit. Pour enlever un boulon (H-36) mal situé, consultez le feuillet d'instructions.

*Usted está en alguna etapa de la instalación de quincallas y le faltan las H-36 :
Antes de llamar para pedir los pernos (H-36), asegúrese de que no los haya instalado en el lugar equivocado.
Para retirar un perno (H-36) mal puesto, consulte el folleto de instrucciones.*

How to separate and install your CO-249 and CO-684 slides:
The CO-249 & CO-684 slides consist of two sections which you must separate. To separate the slides, please refer to your instruction manual. The slides are installed on distinct parts which will be re-grouped only when the drawers are installed on the furniture.

Comment séparer et installer les coulisseaux CO-249 et CO-684 :
Les coulisseaux CO-249 et CO-684 sont constitués d'une partie que vous devez séparer en deux sections. Pour séparer le coulisseau, référez-vous au feuillet d'instructions. Les coulisseaux sont installés sur deux pièces distinctes et seront regroupés seulement lors de l'installation des tiroirs dans le meuble.

*Cómo separar y instalar las guías correderas CO-249 y CO-684 :
Las guías correderas CO-249 y CO-684 están constituidas por una parte que usted debe separar en dos secciones. Para separar las guías correderas, consulte el folleto de instrucciones. Las guías correderas se instalan en dos piezas distintas y sólo serán reagrupadas una vez que se instalen los cajones en el mueble.*

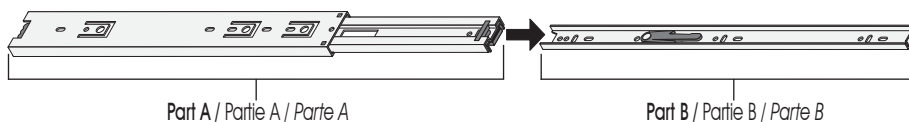

The doors on your furniture are crooked or the space between the doors is uneven:
It is very important to install the hinges and hinge plates on the correct parts while respecting the instruction manual. For the installation and adjustment of the doors, please refer to your instruction manual or log on to the internet site.

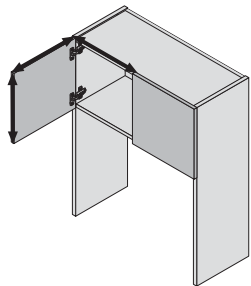

Les portes de votre meuble sont croches ou l'espace qui les sépare est inégal :
Il est important d'installer les pentures et les plaques sur les bonnes pièces en respectant le feuillet d'instructions. Pour l'installation des portes et leur ajustement, référez-vous à l'étape d'installation des portes dans le feuillet d'instructions ou sur le site internet.

*Las puertas de su mueble están chuecas o el espacio que las separa es desigual :
Es importante instalar las bisagras y las placas sobre las piezas adecuadas respetando el folleto de instrucciones. Para la instalación de las puertas y su ajuste, consulte la etapa de instalación de las puertas en el folleto de instrucciones o en el sitio Internet.*

The drawers on your furniture are crooked or the space between the drawers is uneven:
While referring to the section indicating the actual sizes of the screws in your instruction manual , please insure that you are using the correct size screws needed when installing your drawer slides and drawer fronts. They must be installed straight. While installing the drawer front, make sure that the correct side is facing up. For the adjustment of the drawer fronts, please refer to your instruction manual or log on to the internet site.

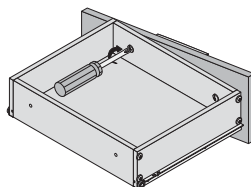

Les tiroirs de votre meuble sont croches ou l'espace qui les sépare est inégal :
En vous référant au tableau de vis grandeur réelle du feuillet d'instructions, assurez-vous que vous avez utilisé les bonnes vis lors de l'installation des coulisseaux ainsi que du devant de tiroir et qu'elles sont posées bien droites. Assurez-vous également que le devant du tiroir n'est pas assemblé à l'envers. Référez-vous à l'étape d'ajustement des tiroirs dans le feuillet d'instructions ou sur le site internet.

*Los cajones de su mueble están chuecos o el espacio que los separa es desigual :
Consulte la tabla de tornillos en tamaño real del folleto de instrucciones y asegúrese de que haya utilizado los tornillos adecuados durante la instalación de las guías correderas así como también la parte delantera del cajón y que éstos estén puestos bien derechos. Asegúrese también de que la parte delantera del cajón no esté ensamblada al revés. Consulte la etapa del ajuste de cajones en el folleto de instrucciones o en el sitio Internet.*