

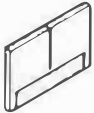

ASSEMBLY INSTRUCTIONS

FULL HEADBOARD
QUEEN HEADBOARD
E.KING/CALKING HEADBOARD

Thank you for purchasing this product. Please take time to read and follow the instructions below. Check that you have all parts and hardware before assembly. Parts apparently missing are often found in the packing materials. If you do not have all the parts listed, have your dealer contact us and they be sent to you immediately.

! It is recommended to install protective pads under all legs and supports to avoid damage or scratches when placing furniture on a wood floor or other hard surface, and to limit indentation and prevent discoloration if placing on carpet.

PARTS LIST			
No.	Description	Sketch	Quantity
A	Headboard		1 PC
B	Headboard Leg		2

STEP 1 : Take the HB Leg (B) out of the inner box from the back of Headboard (A). Attach HB Leg(B) to Headboard(A).

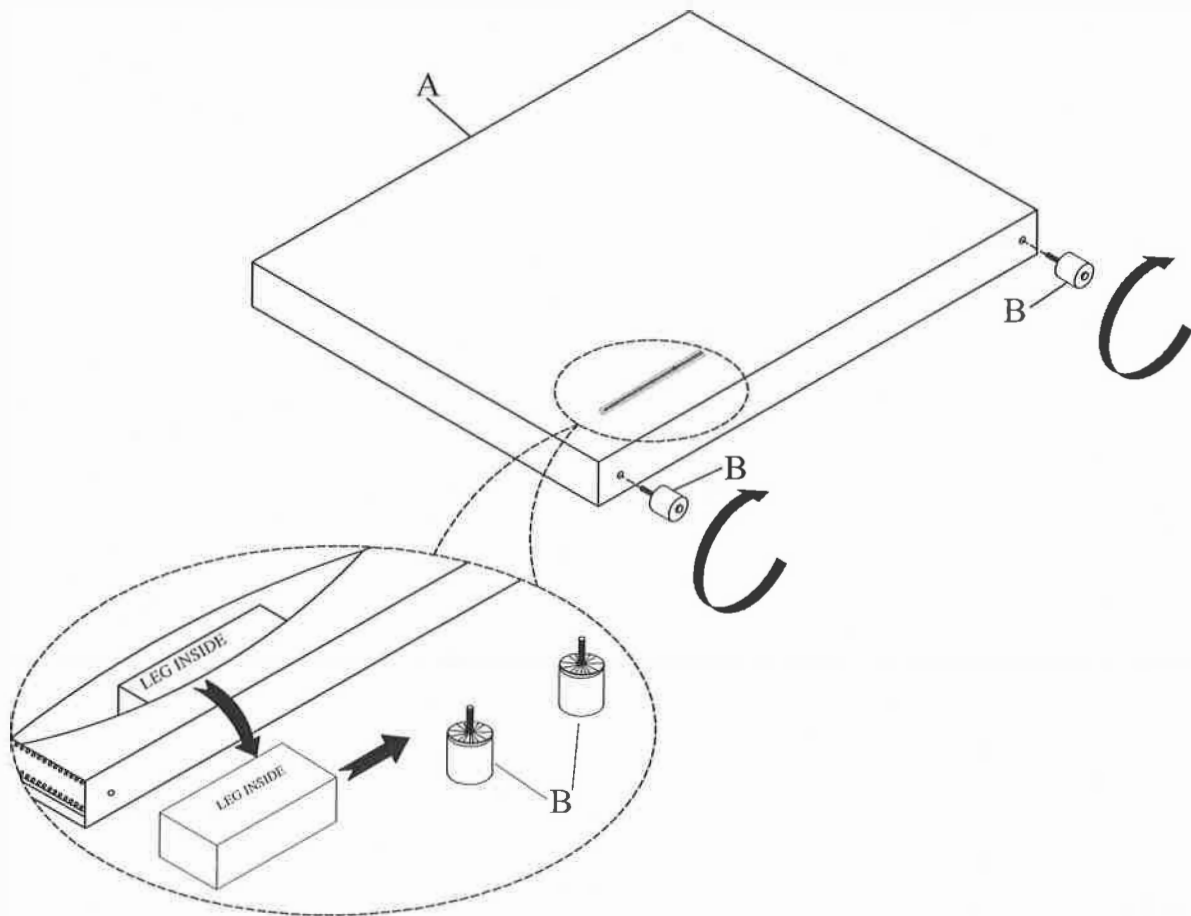





















ASSEMBLY INSTRUCTIONS

CAL KING FOOT BOARD + SIDERAILS WITH 13PCS SLATS

Thank you for purchasing this product. Please take time to read and follow the instructions below. Check that you have all parts and hardware before assembly. Parts apparently missing are often found in the packing materials. If you do not have all the parts listed, have your dealer contact us and they be sent to you immediately.

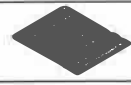
▲ It is recommended to install protective pads under all legs and supports to avoid damage or scratches when placing furniture on a wood floor or other hard surface, and to limit indentation and prevent discoloration if placing on carpet.

HARDWARE LIST				
No.	Description	Sketch	Size	Quantity
1	Allen Bolt		Ø5/16" x 50mmL	4 PCS
2	Spring Washer		Ø5/16"	4 PCS
3	Flat Washer		Ø5/16" x 19mmL	4 PCS
4	Thread Bolt		Ø5/16" x 80mmL	8 PCS
5	Curve Washer		Ø5/16"	8 PCS
6	Hex Nut		Ø5/16"	8 PCS
7	Screw		#4 x 30mmL	27 PCS
8	Allen Bolt		Ø1/4" x 38mmL	2 PCS
9	Open Wrench		Ø5/16"	1 PC
10	Allen Key		4mmL	1 PC
11	Allen Bolt		Ø1/4" x 55mmL	10 PCS
12	Spring Washer		Ø1/4"	10 PCS

PARTS LIST			
No.	Description	Sketch	Quantity
A	Headboard		1 PC
B	Footboard		1 PC
C	Footboard Leg		2 PCS
D	Side Rail		2 PCS
E	Slat Roll		1 Set
F	Center Slat Support		1 PC
G	Support Leg		4 PCS
H	Wood Block		1 PC
I	Cap Rail		2 PCS

STEP 1 : Attach FB Leg(C) to Footboard(B) by using Allen Bolt(1), Spring Washer(2), Flat Washer(3) and Allen Key(10).

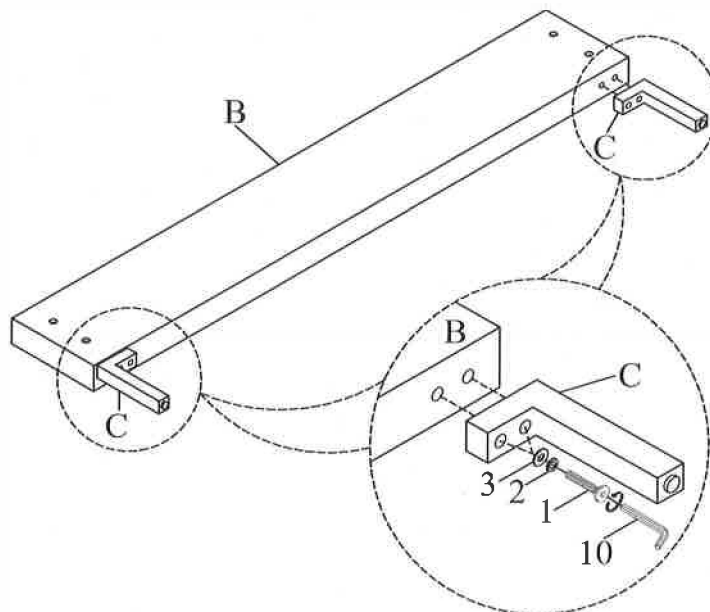

ASSEMBLY INSTRUCTIONS

CAL KING FOOTBOARD + SIDERAILS WITH 13PCS SLATS

STEP 2: Attached the Wood Block(H) to the Footboard(B) by using Allen Bolt(8) and Allen Key(10).

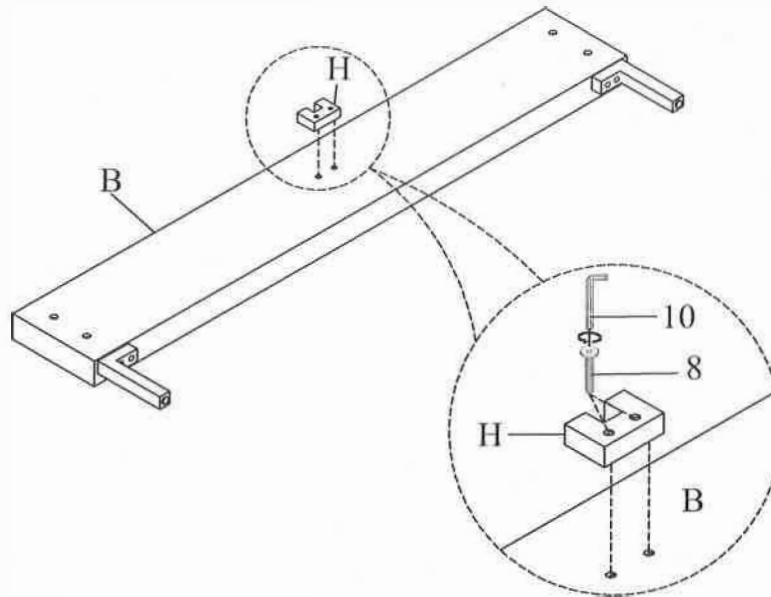

STEP 3: Attach Side Rail(D) to Headboard(A) and Footboard(B) by using Thread Bolt(4), Curve Washer(5), Hex Nut(6) and Open Wrench(9).

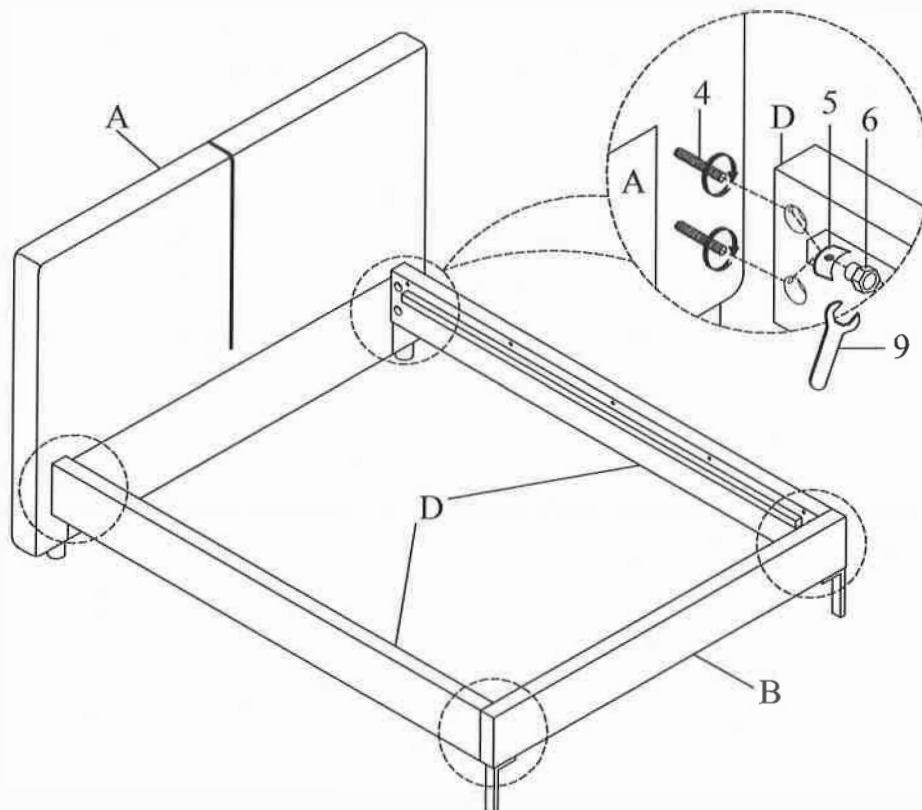

ASSEMBLY INSTRUCTIONS

CAL KING FOOTBOARD + SIDERAILS WITH 13PCS SLATS

STEP 4 : Attached the Support Leg(G) and Center Slat Support(F) to the Slat Roll(E).

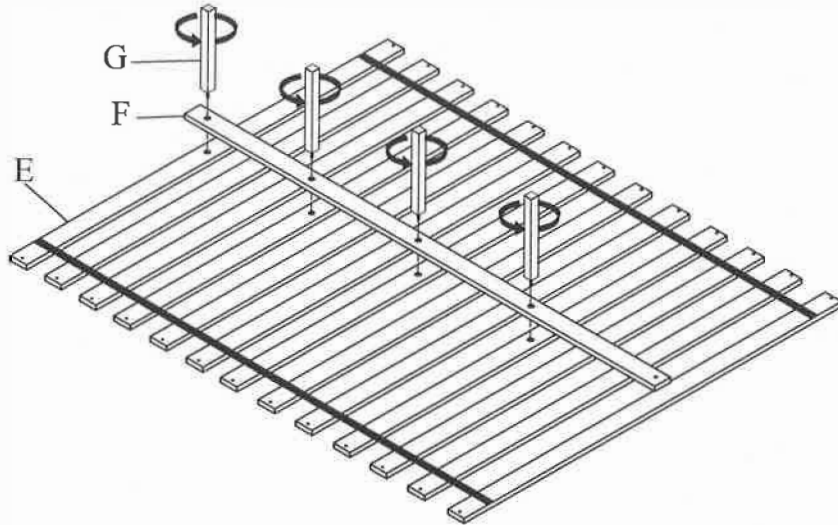

STEP 5 : Then place Slat Roll(E) on Side Rail.

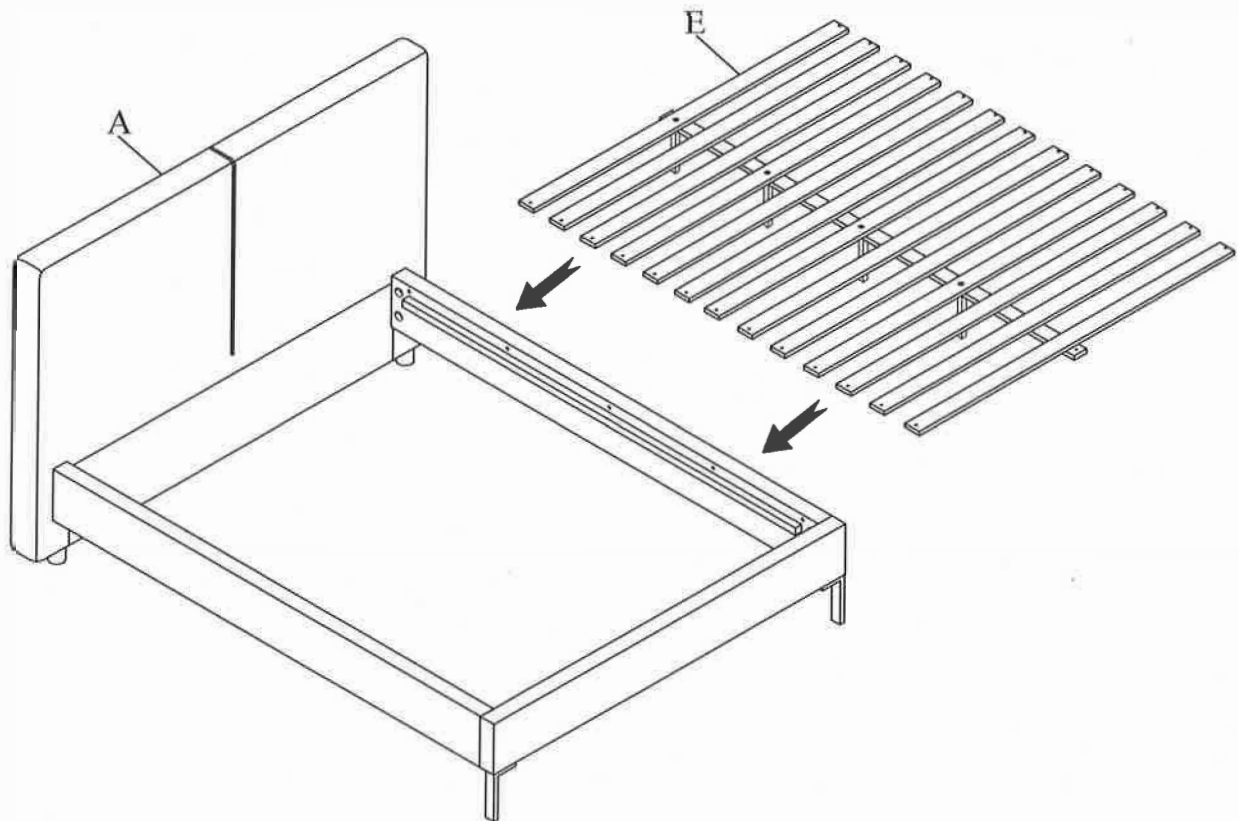

ASSEMBLY INSTRUCTIONS

CAL KING FOOTBOARD + SIDERAILS WITH 13PCS SLATS

STEP 6 : Attached the Center Slat Support(F) to the Wood Block(H) by using Screw(7).
Attached the Slat Roll(E) to the Side Rail(D) by using Screw(7).
NOTE: SCREWDRIVER NOT INCLUDED.

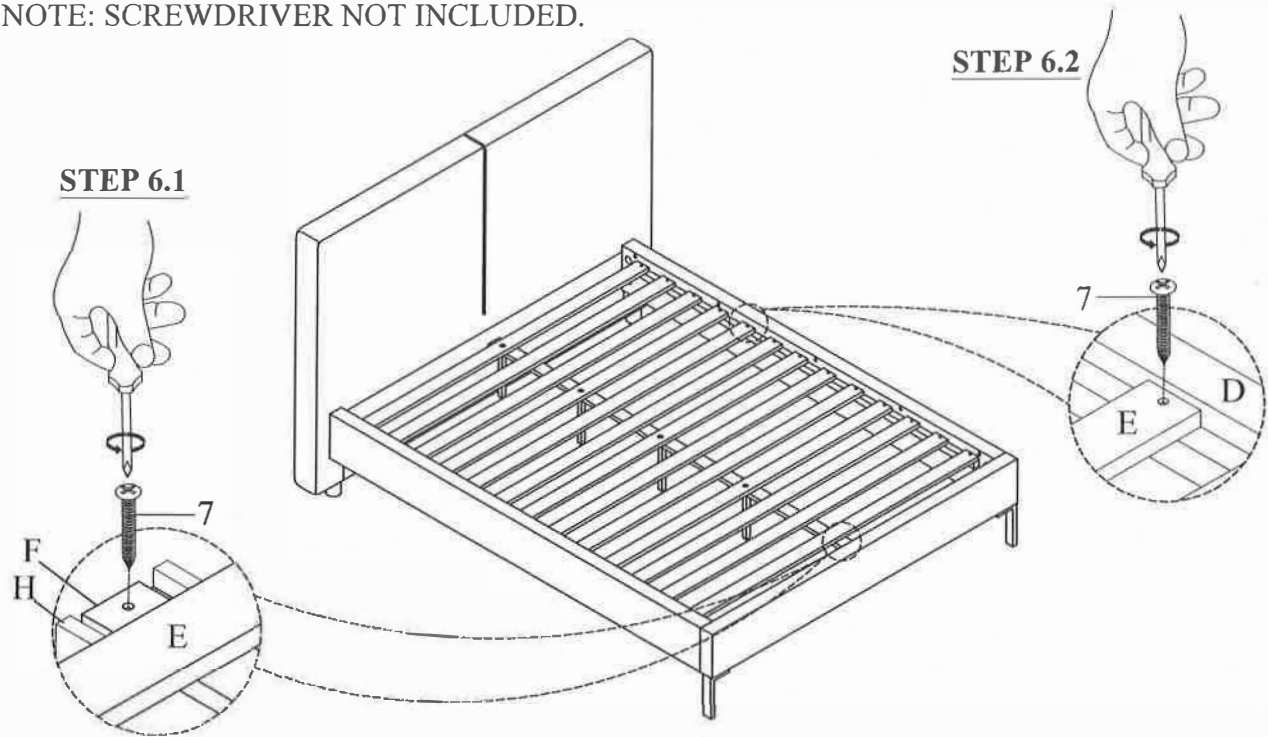

STEP 7 : Attached the Cap Rail(I) to the Side Rail(D) by using Allen Bolt(11), Spring Washer(12) and Allen Key(10).

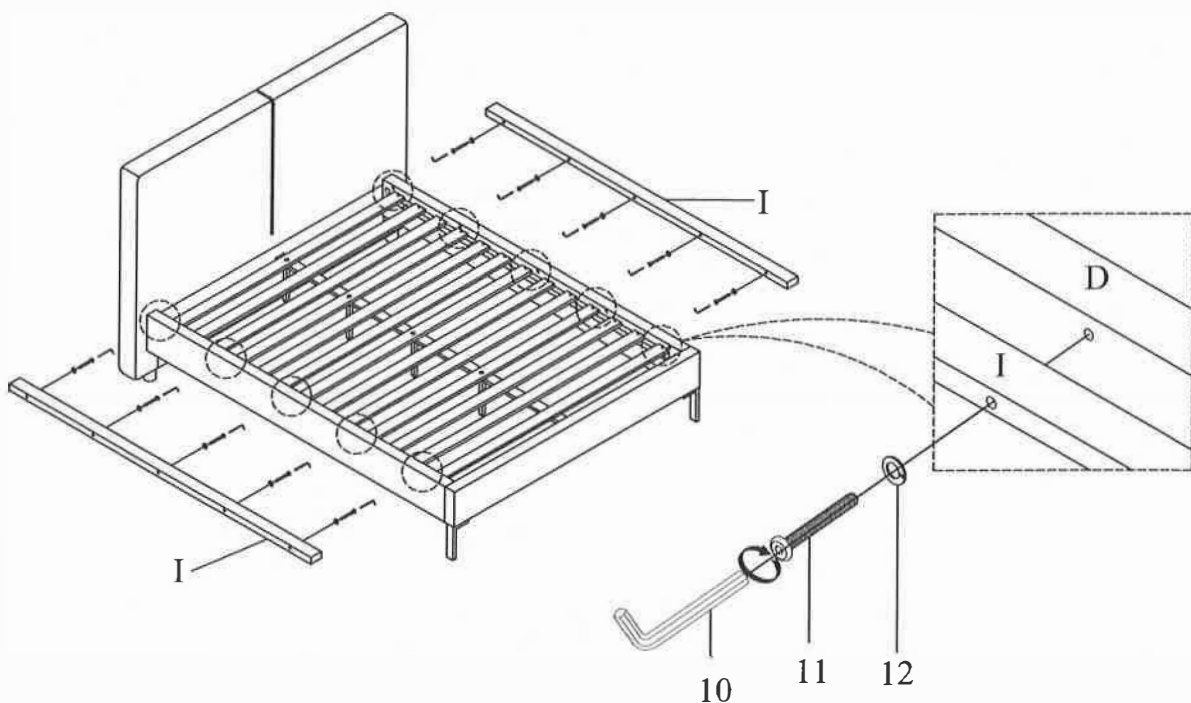

ASSEMBLY INSTRUCTIONS

CAL KING FOOTBOARD + SIDERAILS WITH 13PCS SLATS

COMPLETE

