

# W Series

Installation Instructions for W Series Single (WS-LEFT & WS-RIGHT)

## Parts List

- 1 "Single" Rack
- 2 Screws
- 2 Toggle Bolts
- 2 Mounting Hole Caps

## Required Tools

- Phillips head screw driver
- Level
- Pencil
- Tape Measure
- Drill

### Side Note:

Concrete, Brick or Stucco: 3/16" x 1 1/4" masonry screw or #8 x 1 1/4 inch screw with appropriate size expanding concrete anchor - not included

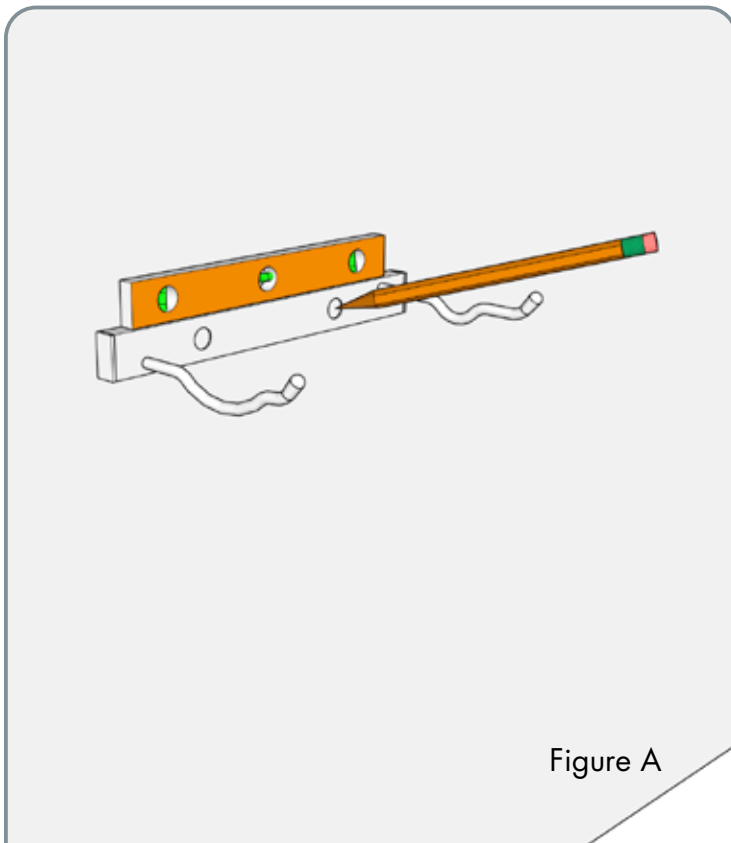

Figure A

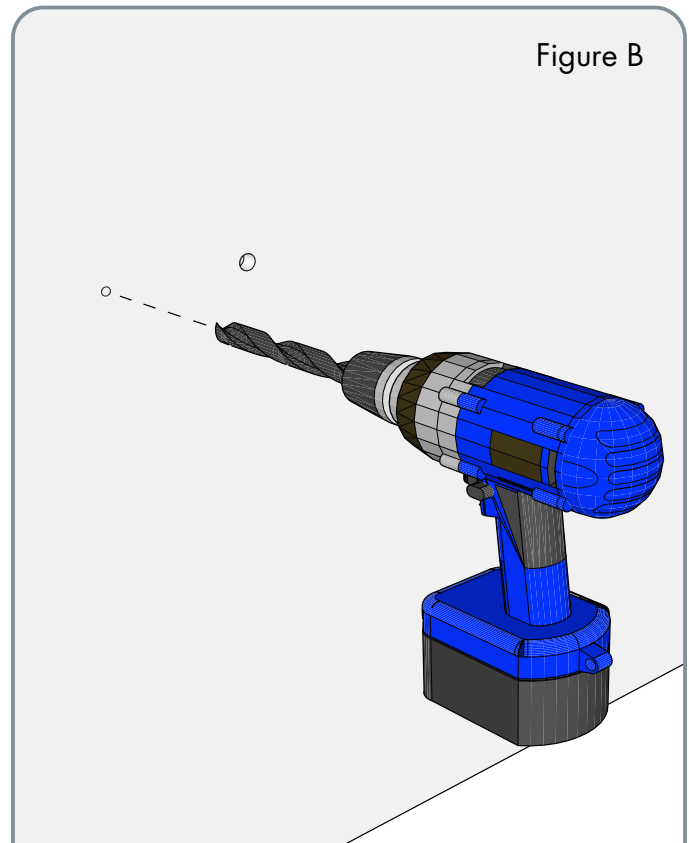

Figure B

**1. Mark the mounting hole locations –** (See image below) to ensure appropriate minimum clearance around the Single and hold the rack against the wall. Use a level to ensure the rack is horizontal and mark the mounting hole locations on the wall.

**2a. Drill anchor holes for drywall –** Drill 1/16 in pilot holes to determine if the holes are over a stud. Drill 1/2 in (13.7mm) hole for the Toggle Bolts centered on the marked hole locations.

**2b. Install into wood –** use a screw to fasten the strip into the wood/stud at mounting point.

## Instructions

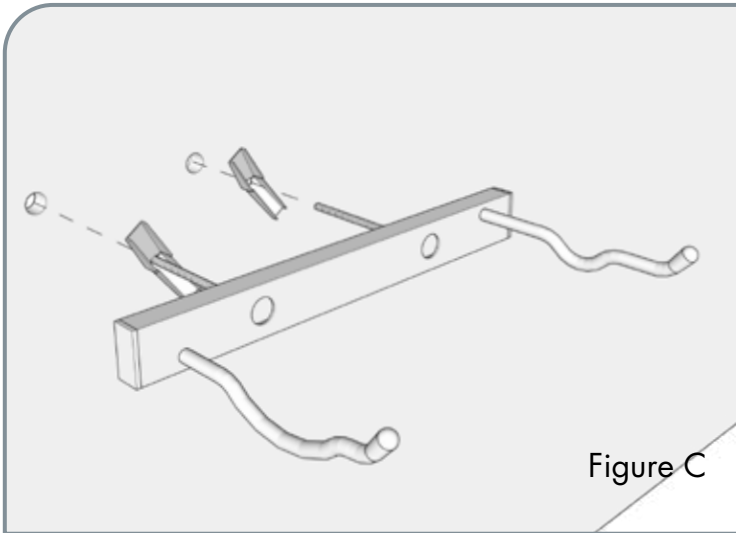

**3. Install the rack** - Remove the expanding nuts from the Toggle Bolts. Insert the bolts through the mounting holes and, with the wings of the nut oriented to fold toward the head of the bolt, thread an expanding nut back onto each bolt until the tip of the bolt starts to protrude from the end of the nut. Hold the strip so the Toggle Bolt aligns with the  $\frac{1}{2}$  inch holes and gently push the expanding nut through the wall. Ensure that the wings of the expanding nuts have fully expanded on the back side of the wall and tighten the bolts, verifying that the rack remains level.

**4. Install mounting hole caps** in the  $\frac{1}{2}$  in holes on the face of the rack by pressing into place.

**5. Add Wine** Only the good stuff.

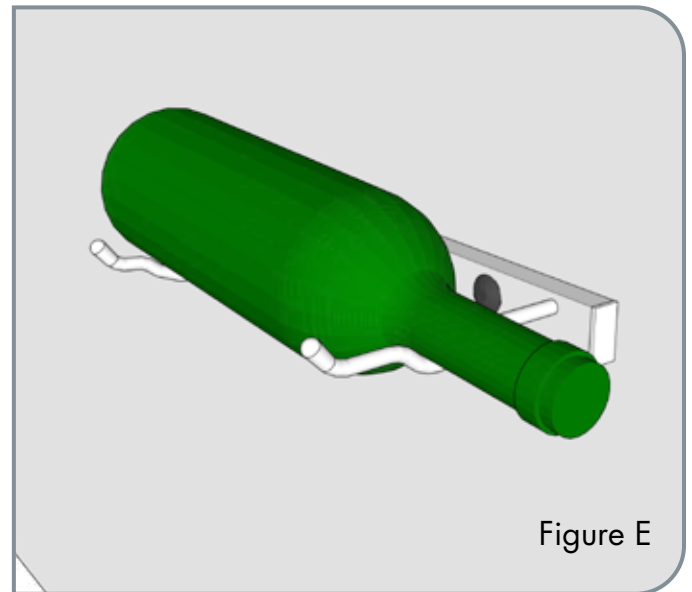
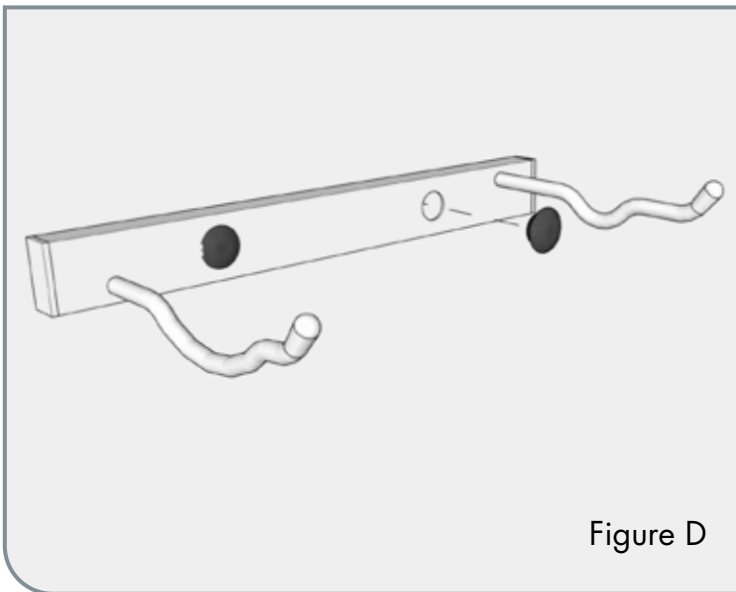

**Maintenance and Care** - Your W Series racks should be regularly inspected for secure wall attachment. Should any fastener be found to be loose, tighten it appropriately. If the wall surface shows any signs of breakage, discontinue use immediately until such time as the wall may be adequately repaired. W Series racks may be cleaned with a damp cloth and mild dish soap – avoid vinegar, harsh chemicals such as bleach or degreasing agents, abrasive cleaners, abrasive pads or steel wool.