

Installation Instruction

SKU:N606P339348/N606P339349

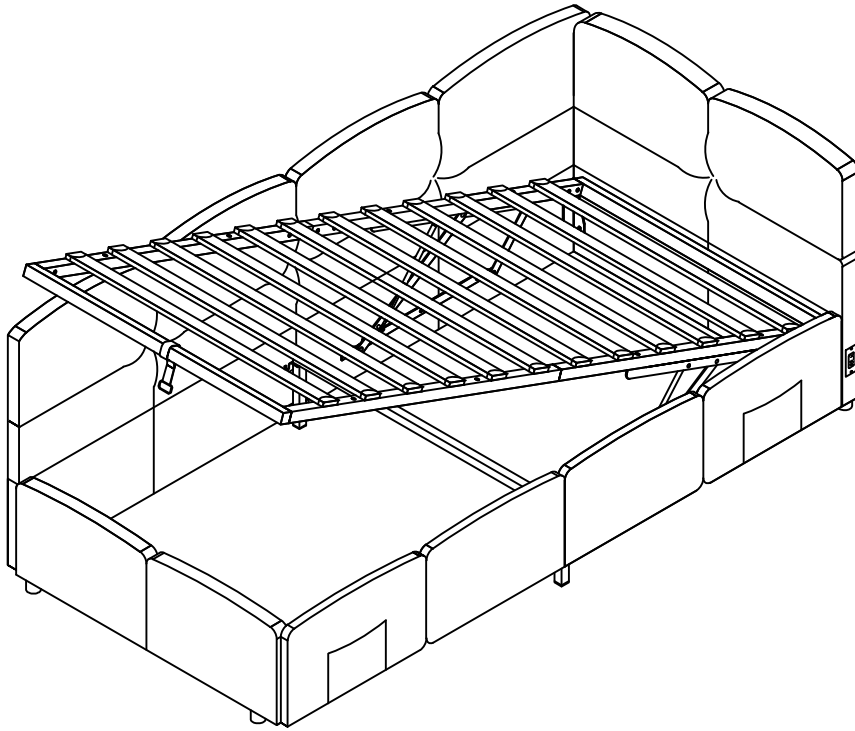

DE:Unser Produkt wird Ihnen in 2 Paketen geliefert. Die Lieferzeiten dieser 2 Pakete können abweichen, bitte haben Sie etwas Geduld und vielen Dank für Ihr Verständnis.

UK:Our product will be delivered to you in 2 packages. The delivery times of these 2 packages may differ, please be patient and thank you for your understanding.

FR:Notre produit vous sera livré en 2 colis. Les délais de livraison de ces 2 colis peuvent différer, soyez patient et merci pour votre compréhension.

**UK
CA**



English

IMPORTANT FOR GAS LIFT BEDS&MAINTAINANCE

- Please place the mattress on top of the bed frame.
- Please do not pull on the strap handles.
- Please press heavily to release the compressed gas.
- Periodically check all screw & fixings to ensure they are secure.
- When moving your product, carefully lift into place.
- Wipe clean with a slightly damp cloth- please do not use abrasive chemicals or bleach.
- Do NOT allow children to operate the lift mechanism.
- Do NOT allow children near the lift base when operating the mechanism.
- Do NOT stand inside the bed or the internal storage base.
- Do NOT overload the internal storage base.
- DO NOT jump on the product or any of its parts.

Deutsch

WICHTIG FÜR GASLIFT-BETTEN&WARTUNG

- Bitte legen Sie die Matratze oben auf den Bettrahmen.
- Bitte ziehen Sie nicht an den Gurtgriffen.
- Bitte drücken Sie kräftig, um das komprimierte Gas freizusetzen.
- Überprüfen Sie regelmäßig alle Schrauben und Befestigungen, um sicherzustellen, dass sie sicher sind.
- Wenn Sie Ihr Produkt bewegen, heben Sie es vorsichtig an seinen Platz.
- Mit einem leicht feuchten Tuch abwischen - bitte keine scheuernden Chemikalien oder Bleichmittel verwenden.
- Erlauben Sie Kindern NICHT, den Hebemechanismus zu bedienen.
- Lassen Sie Kinder NICHT in die Nähe des Liftsockels, wenn Sie den Mechanismus bedienen.
- Stellen Sie sich NICHT in das Bett oder in die Innenablage.
- Überlasten Sie den internen Liftsockel NICHT.
- Springen Sie NICHT auf das Produkt oder eines seiner Teile.

Français

IMPORTANT POUR LES LITS À RELEVAGE DE GAZ&MAINTENANCE

- Veuillez placer le matelas sur le dessus du cadre de lit.
- Ne tirez pas sur les poignées de la sangle.
- Appuyez fortement pour libérer le gaz comprimé.
- Vérifiez régulièrement que toutes les vis et fixations sont bien en place.
- Lorsque vous déplacez votre produit, soulevez-le avec précaution pour le mettre en place.
- Nettoyez avec un chiffon légèrement humide - n'utilisez pas de produits chimiques abrasifs ou d'eau de Javel.
- Ne laissez pas les enfants utiliser le mécanisme de levage.
- Ne laissez pas les enfants s'approcher de la base de levage lorsqu'ils actionnent le mécanisme.
- Ne vous tenez PAS à l'intérieur du lit ou de la base de stockage interne.
- Ne surchargez pas la base de stockage interne.
- Ne pas sauter sur le produit ou l'une de ses parties.

Italiano

IMPORTANTE PER I LETTI CON SOLLEVAMENTO A GAS E LA MANUTENZIONE

- Posizionare il materasso sopra la struttura del letto.
- Non tirare le maniglie della cinghia.
- Premere con forza per rilasciare il gas compresso.
- Controllare periodicamente tutte le viti e i fissaggi per assicurarsi che siano saldi.
- Quando si sposta il prodotto, sollevarlo con cautela.
- Pulire con un panno leggermente umido, senza usare prodotti chimici abrasivi o candeggina.
- NON permettere ai bambini di azionare il meccanismo di sollevamento.
- NON permettere ai bambini di avvicinarsi alla base di sollevamento quando si aziona il meccanismo.
- NON sostare all'interno del letto o della base di contenimento interna.
- NON sovraccaricare la base di contenimento interna.
- NON saltare sul prodotto o sulle sue parti.

Español

IMPORTANTE PARA LAS CAMAS ELEVADORAS DE GAS&MANTENIMIENTO

- Coloque el colchón sobre el somier.
- No tire de las asas de la correa.
- Presione con fuerza para liberar el gas comprimido.
- Compruebe periódicamente que todos los tornillos y fijaciones estén bien sujetos.
- Al mover el producto, levántelo con cuidado para colocarlo en su sitio.
- Limpie con un paño ligeramente humedecido; no utilice productos químicos abrasivos ni lejía.
- NO permita que los niños accionen el mecanismo de elevación.
- NO permita que los niños se acerquen a la base elevadora cuando accionen el mecanismo.
- NO se ponga de pie dentro de la cama o de la base de almacenamiento interna.
- NO sobrecargue el somier.
- NO salte sobre el producto ni sobre ninguna de sus piezas.





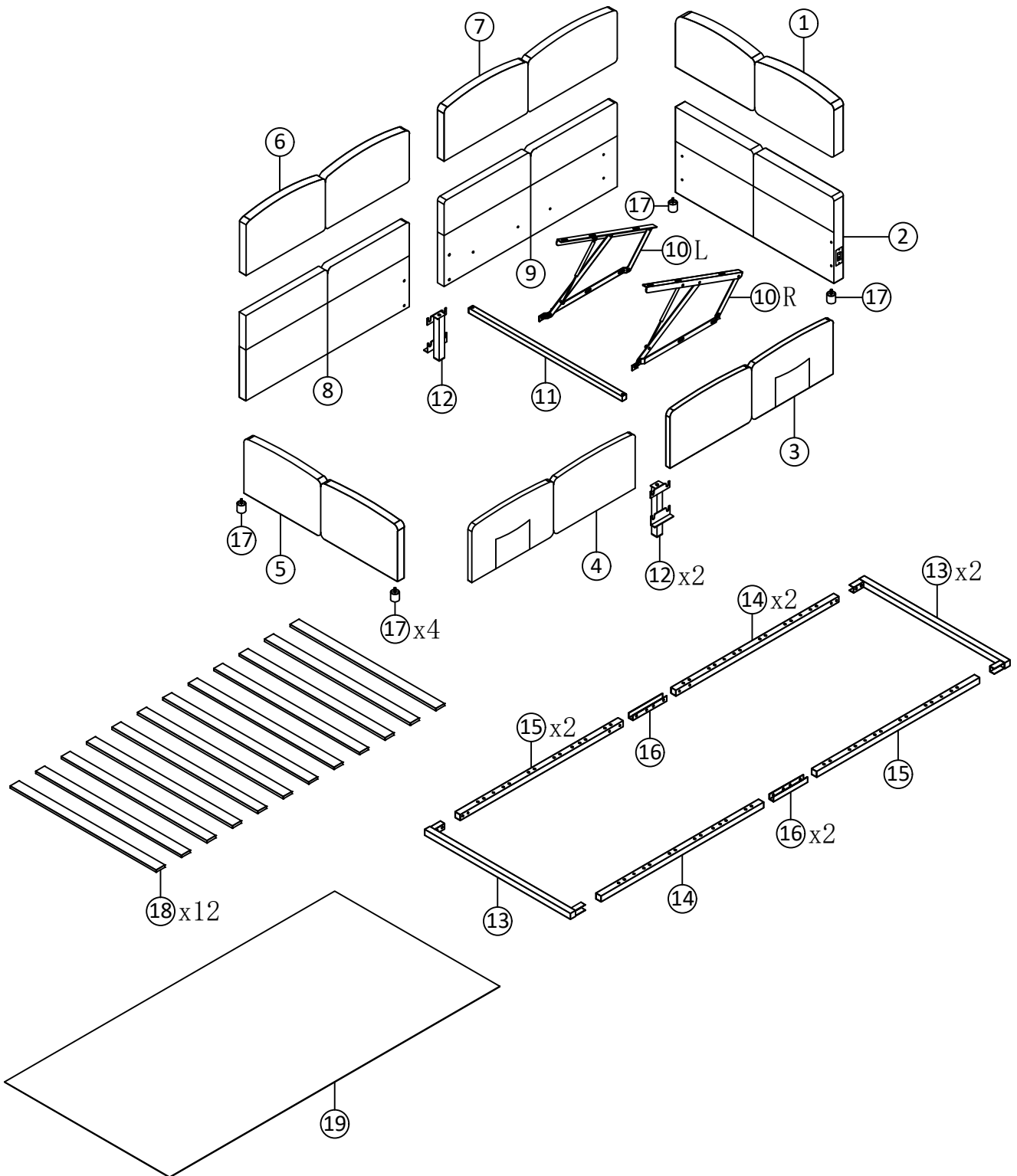

Detail View



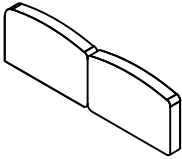
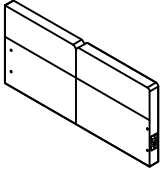
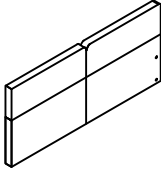
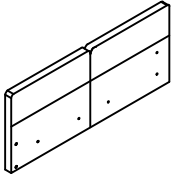
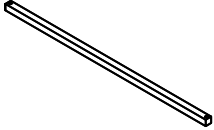

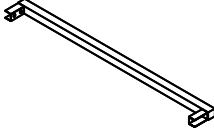
Part List

N606P339349



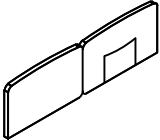
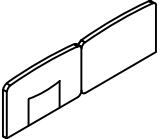
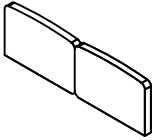
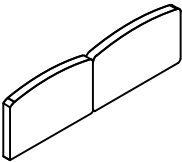
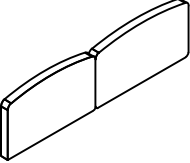
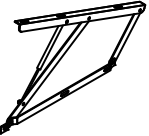

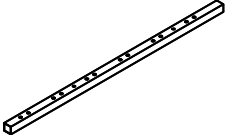
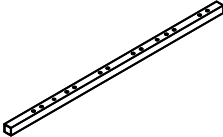
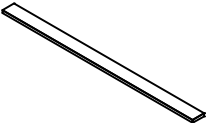
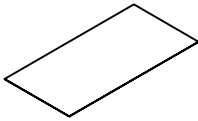





<p>1</p>  <p>Top head board -1PC</p>	<p>2</p>  <p>Base head board -1PC</p>	<p>8</p>  <p>Bottom back rest -1PC</p>	<p>9</p>  <p>Bottom back rest -1PC</p>
<p>11</p>  <p>Metal cross bar -1PC</p>	<p>12</p>  <p>Side rails Support legs -2PCS</p>	<p>13</p>  <p>Metal frame cross bar -2PCS</p>	<p>16</p>  <p>Connection fitting -2PCS</p>
<p>17</p>  <p>Bed legs-4PCS</p>			

N606P339348

<p>3</p>  <p>Side rail -1PC</p>	<p>4</p>  <p>Side rail -1PC</p>	<p>5</p>  <p>Foot board -1PC</p>	<p>6</p>  <p>Back rest -1PC</p>
<p>7</p>  <p>Back rest -1PC</p>	<p>10R</p>  <p>Gas lift -1PC</p>	<p>10L</p>  <p>Gas lift -1PC</p>	<p>14</p>  <p>Metal frame side bar -2PCS</p>
<p>15</p>  <p>Metal frame side bar -2PCS</p>	<p>18</p>  <p>Slat-12PCS</p>	<p>19</p>  <p>Black non woven fabric-1PC</p>	

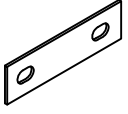
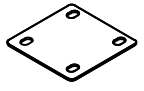
Hardware List

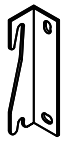
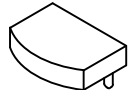
N606P339349

Ax1  Allen Key	Bx80  M8x18mm Bolts	Cx6  M8x45mm Bolts
Dx6  Nuts	Ex4  Nuts	Fx1  Spanner
Gx1  Two hole iron	Hx6  Four hole iron	Ix4  Metal Corner
Jx2  Hinge	Kx24  End slats cap	Lx1  Pull tape

DE: Vor dem Einbau die Schrauben in die Löcher stecken und festziehen, aber nicht bis 100%, 70% bis 80% anziehen reicht aus. Schließlich, nachdem alle Schrauben installiert sind, ziehen Sie alle Schrauben auf 100%.

Wenn Sie auf diese Probleme stoßen, wie z. B. Fehlausrichtung der Löcher oder Unfähigkeit, bestimmte Teile zu installieren, überprüfen Sie bitte, ob die Schrauben korrekt verwendet werden und passen Sie die Dichtigkeit der Schrauben an.

UK: Before installation, insert the screws into the holes and tighten them, but do not tighten them to 100%, 70% to 80% is sufficient. Finally, after all screws are installed, tighten all screws to 100%.

If you encounter these issues, such as if the holes cannot be aligned or some parts cannot be installed, please check if the screws are used correctly and adjust the tightness of the screws.

FR: Insérer la vis dans le trou avant la fin de l'assemblage, serrer la vis, mais ne pas serrer à 100%, 70% ~ 80% est correct. Enfin, une fois que toutes les vis sont bien serrées, toutes les vis sont serrées à 100%.

Si vous rencontrez ces problèmes, par exemple si les trous ne sont pas alignés ou si certaines pièces ne peuvent pas être montées, vérifiez que les vis sont utilisées correctement et Ajustez leur serrage.

Attention: Do not tighten the screws before completing the entire installation. If you have any difficulty with the installation process, please feel free to contact us.

Step 1:

Fix the Side rails Support legs (12) to the Side rail (3), Side rail (4), Bottom back rest (8) and Bottom back rest (9) with Bolts B by using Allen key A.

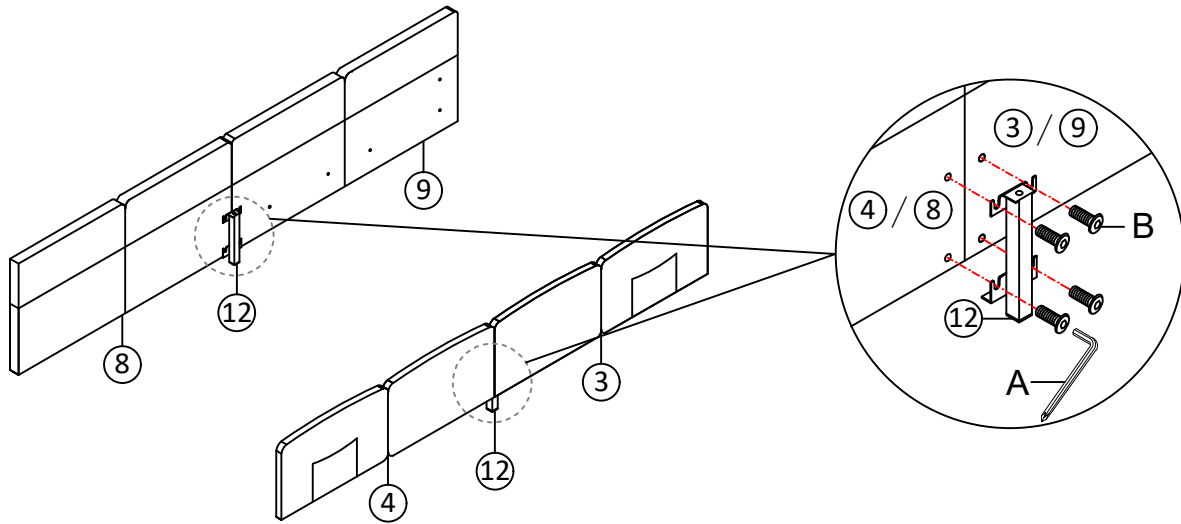

A Allen Key



B Bolts x 8



M8x18mm

Step 2:

Fix the Base head board (2) to the Side rail (3) and Bottom back rest (9) with Bolts B and Hinge J by using Allen key A.

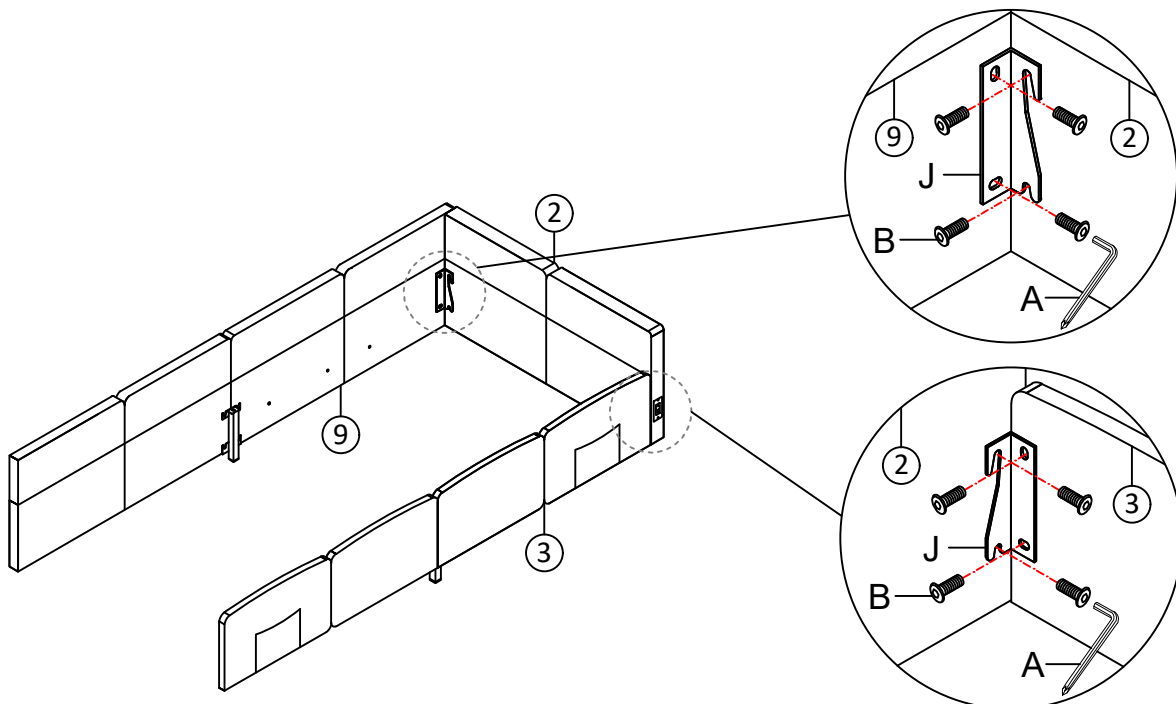

A Allen Key



B Bolts x 8



M8x18mm

J Hinge x 2



Step 3:

Fix the Foot board (5) to the Side rail (4) and Bottom back rest (8) with Bolts B and Metal Corner I by using Allen key A.

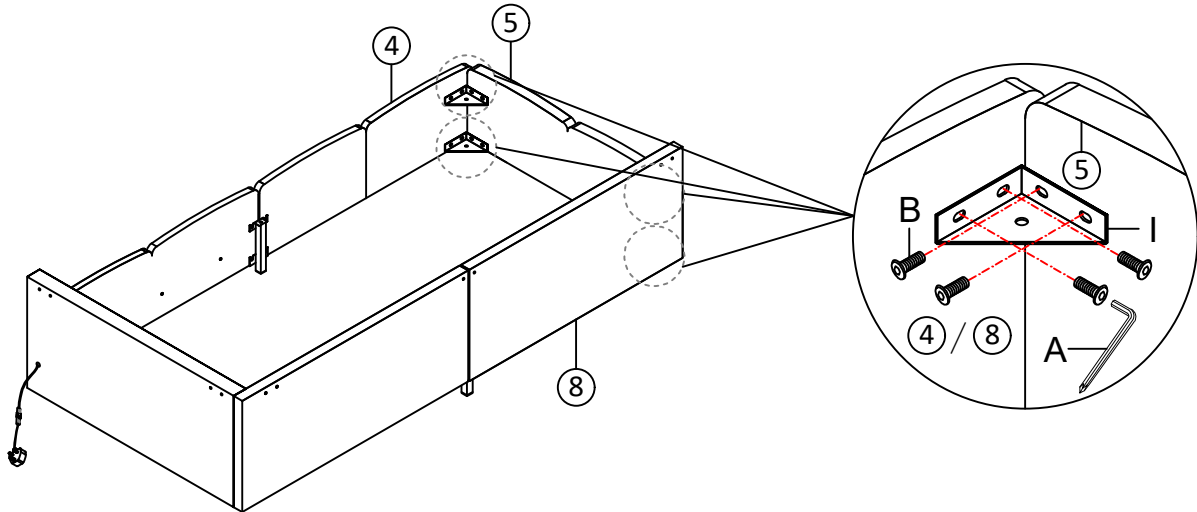

A Allen Key



B Bolts x 16



M8x18mm

I Metal Corner x 4



Step 4:

Fix the Top head board (1) to the Base head board (2) with Bolts B and Four hole iron H by using Allen key A.

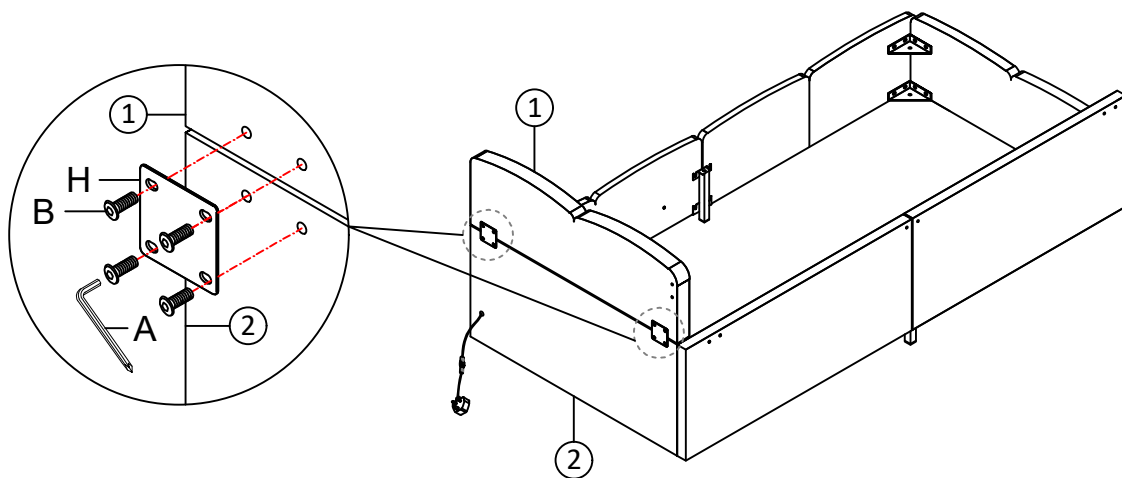

A Allen Key



B Bolts x 8



M8x18mm

H Four hole iron x 2



Step 5:

Fix the Back rest ⑥ to the Back rest ⑦ with Bolts B and Two hole iron G by using Allen key A.

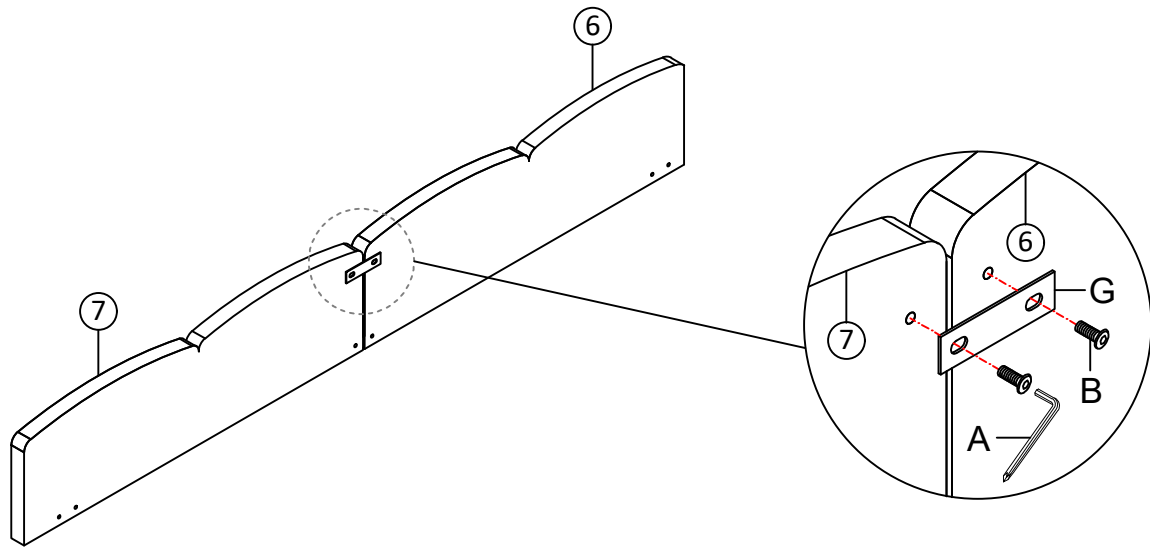

A Allen Key



B Bolts x 2



M8x18mm

G Two hole iron x 1



Step 6:

Fix the Back rest ⑥ and Back rest ⑦ to the Bottom back rest ⑧ and Bottom back rest ⑨ with Bolts B and Four hole iron H by using Allen key A.

Fix the Top head board ① to the Back rest ⑦ with Bolts B and Four hole iron H by using Allen key A.

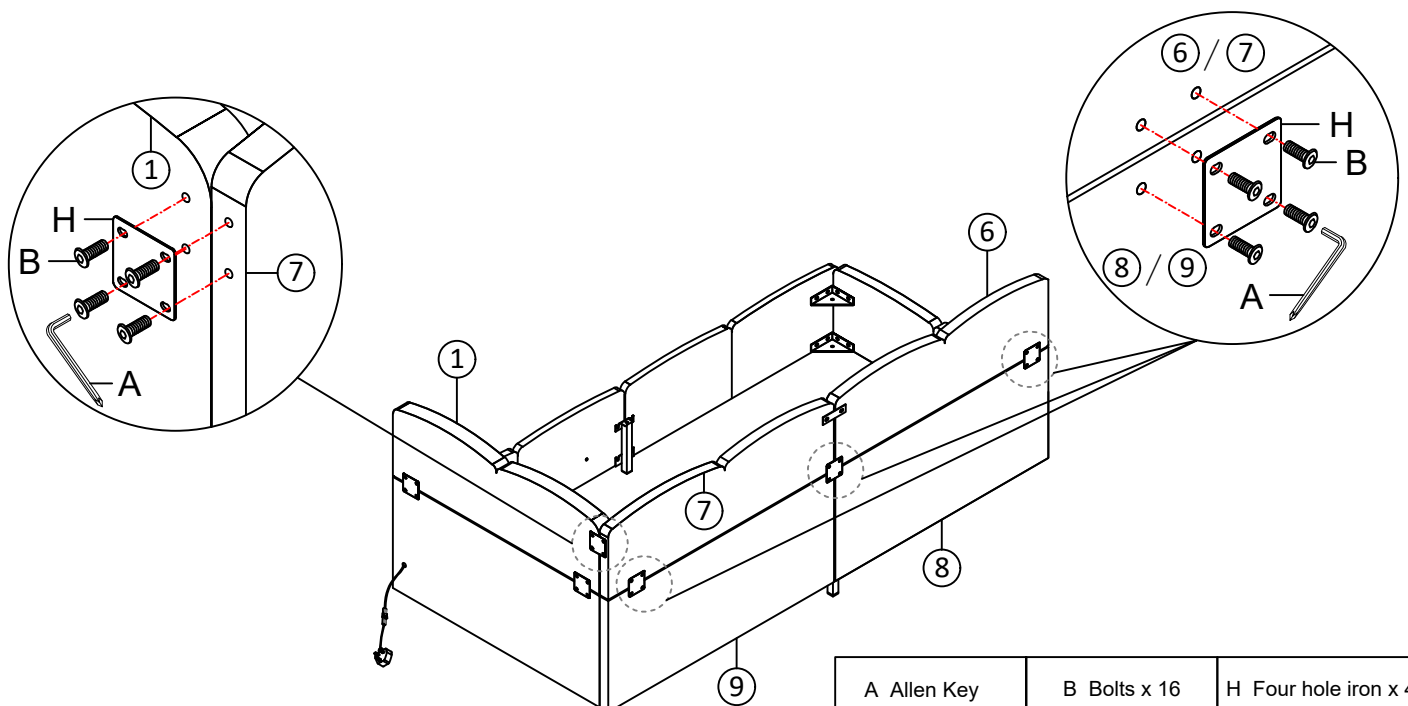

A Allen Key



B Bolts x 16



M8x18mm

H Four hole iron x 4



Step 7:

Fix the Metal cross bar (11) to the Side rails Support legs (12) with Bolts C by using Allen key A.

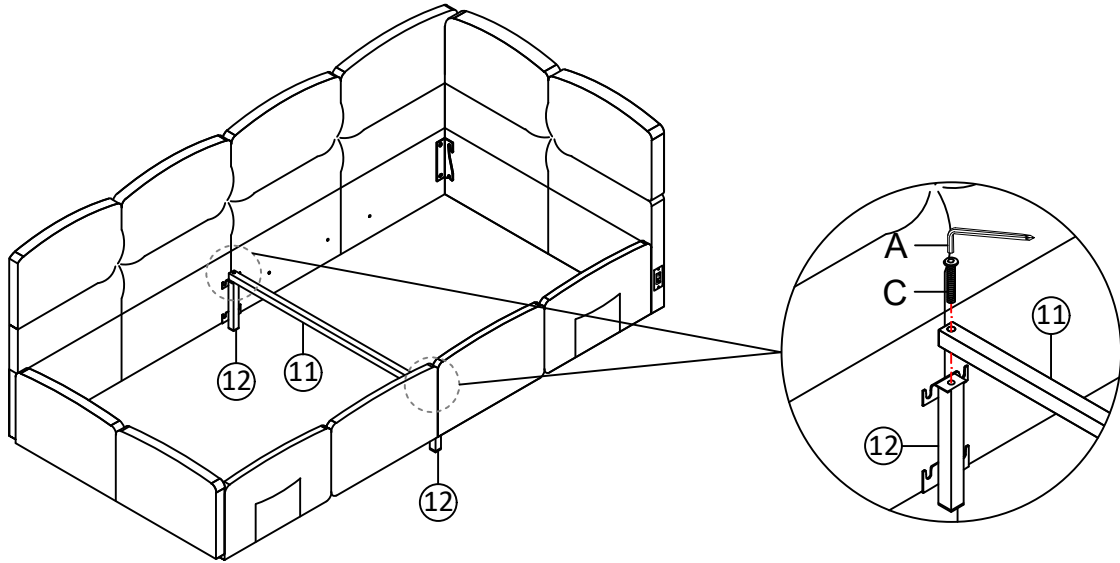

A Allen Key



C Bolts x 2



M8x45mm

Step 8:

Fix the Bed legs (17) to the Base head board (2) and Metal Corner I with Nuts D by using Spanner F.

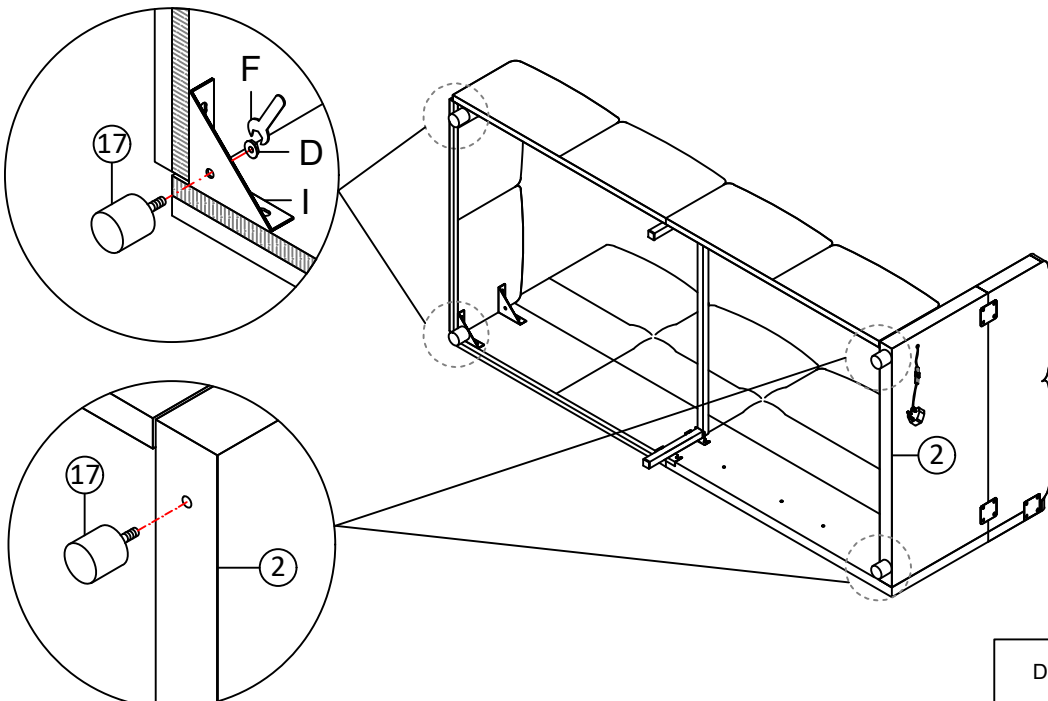

D Nuts x 2



F Spanner



Step 9:

Stick the Black non-woven fabric (19) to the bottom of bed .

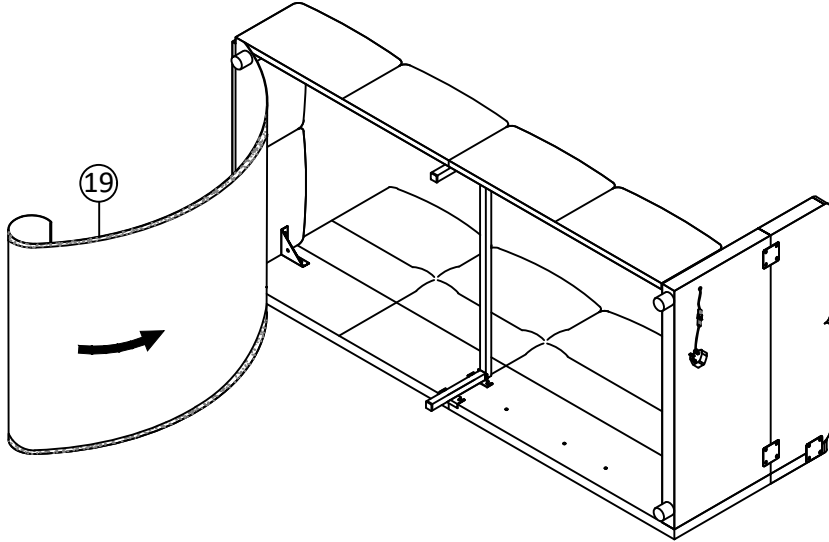

Step 10:

Fix the Gas lift (10) to the Side rail (3) and Bottom back rest (9) with Bolts B and Nuts E by using Allen key A and Spanner F.

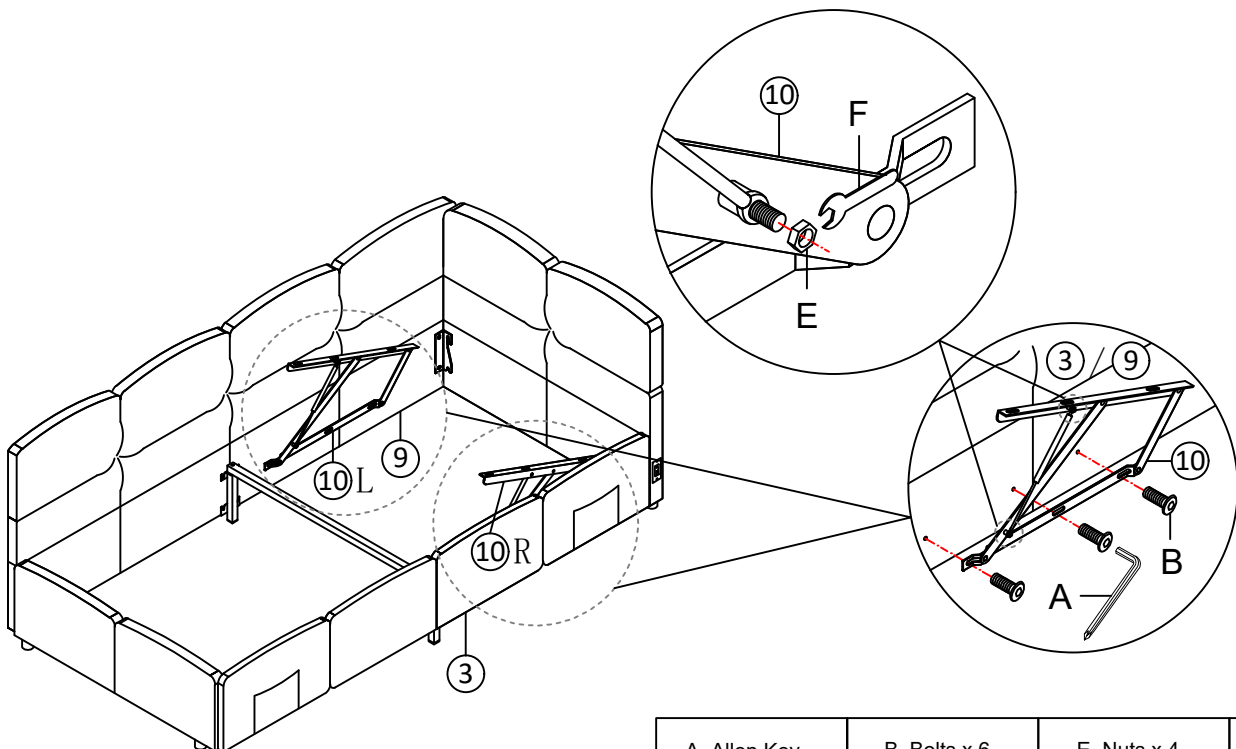

A Allen Key



B Bolts x 6



E Nuts x 4



F Spanner



Step 11:

Connect the Metal frame side bar ⑭ and ⑮ together with Connection fitting ⑯ and Bolts B by using Allen key A.

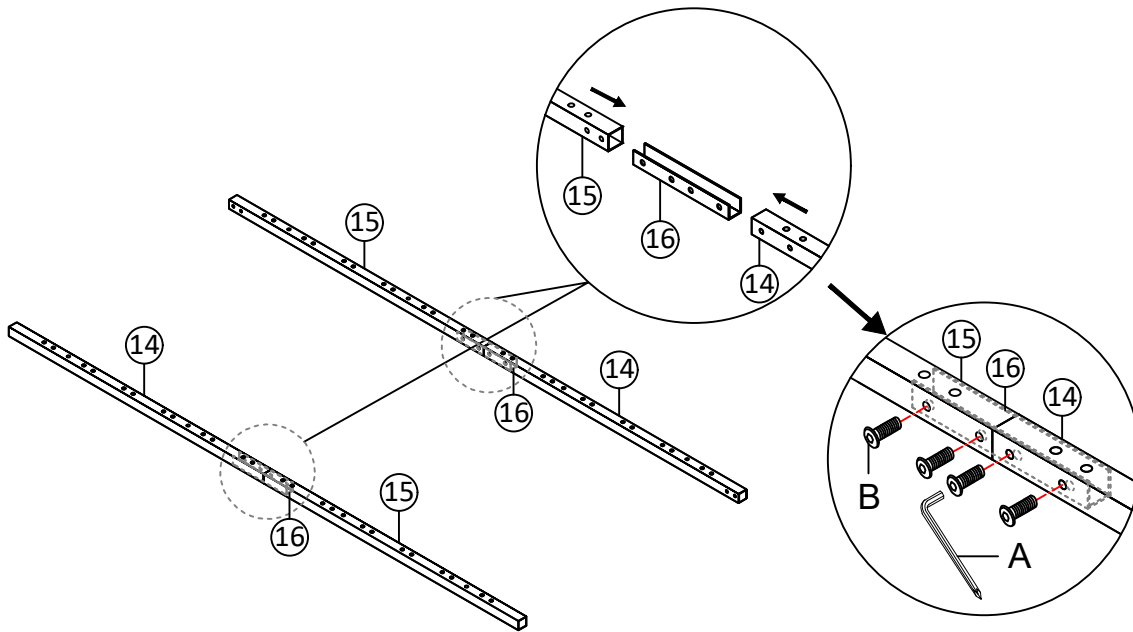

A Allen Key



B Bolts x 8



M8x18mm

Step 12:

Fix the Metal frame cross bar ⑬ to the Metal frame side bar ⑭ and ⑮ with Bolts B by using Allen key A.

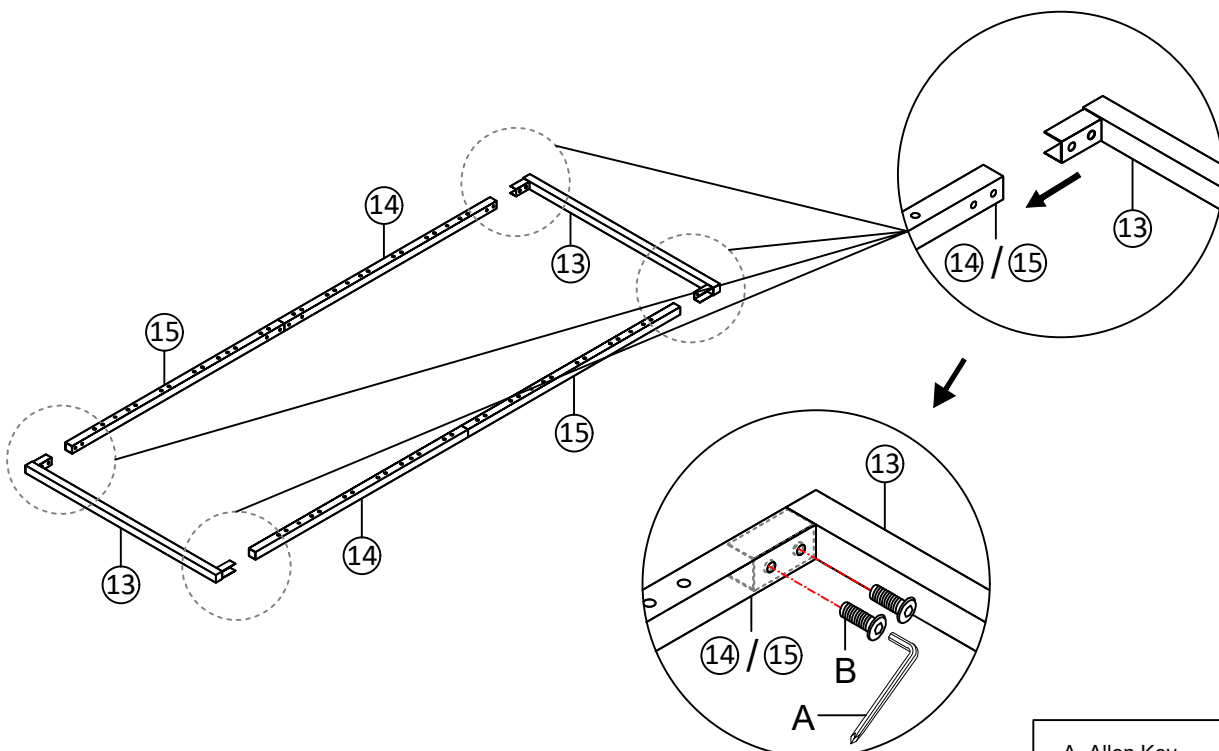

A Allen Key



B Bolts x 8



M8x18mm

Step 13:

Assemble the slats into the assembled slats frame with End slats cap K.

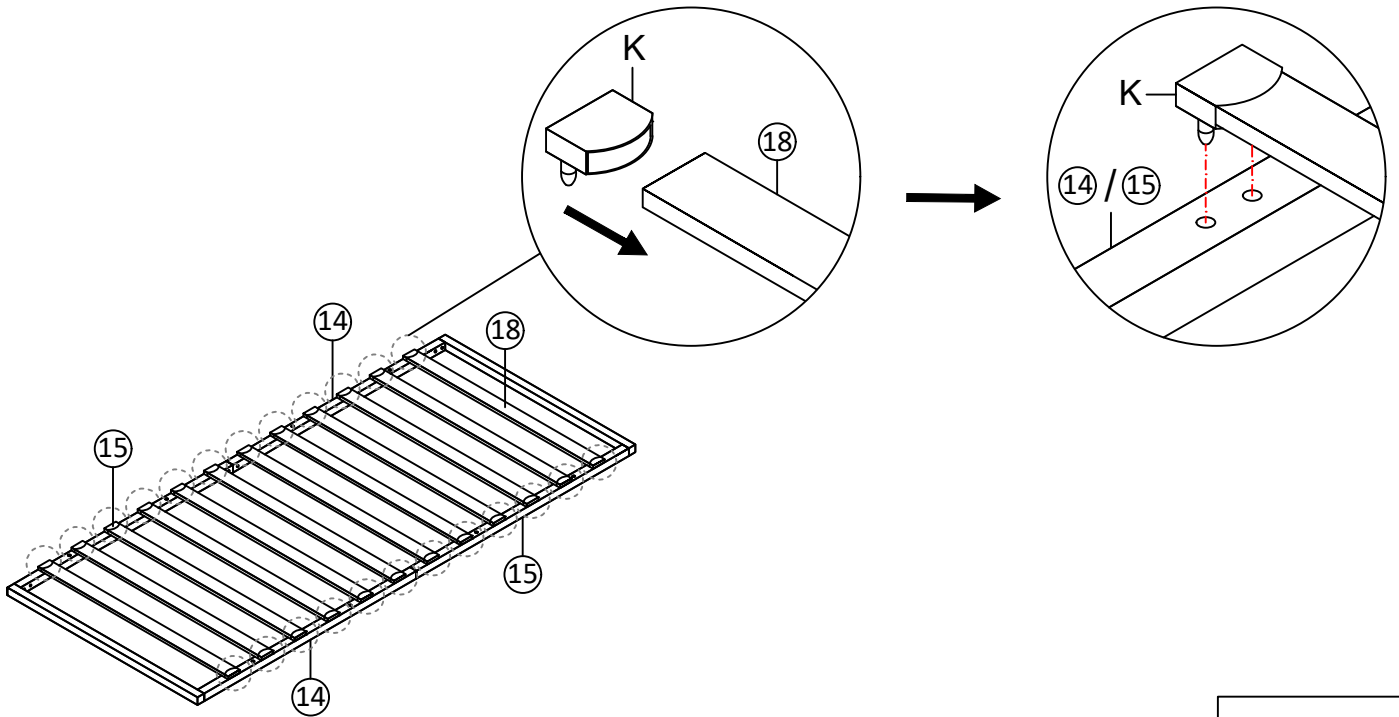

K End slats cap x 24



Step 14:

Fix the assembled slats frame to the Gas lift (10) with Bolts C and Nuts D by using Allen key A and Spanner F. Put the pull tape L in side middle of the slat frame.

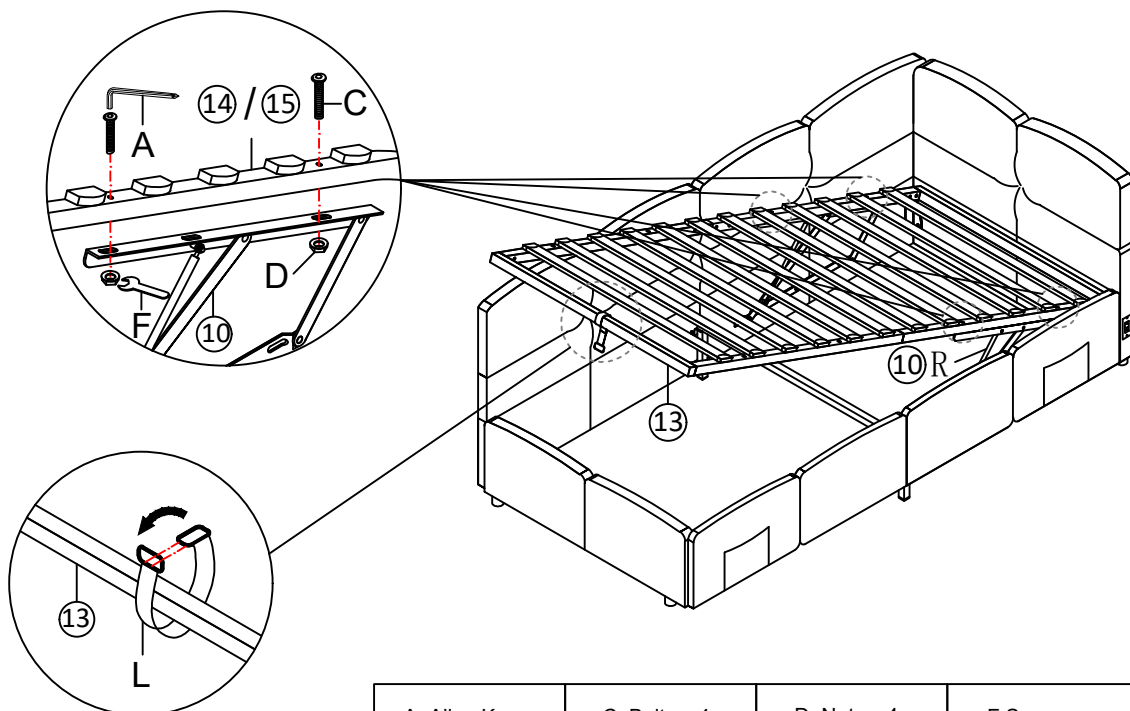

A Allen Key



C Bolts x 4



M8x45mm

D Nuts x 4



F Spanner



L Pull tape x 1



Step 15:

Please connect to power.

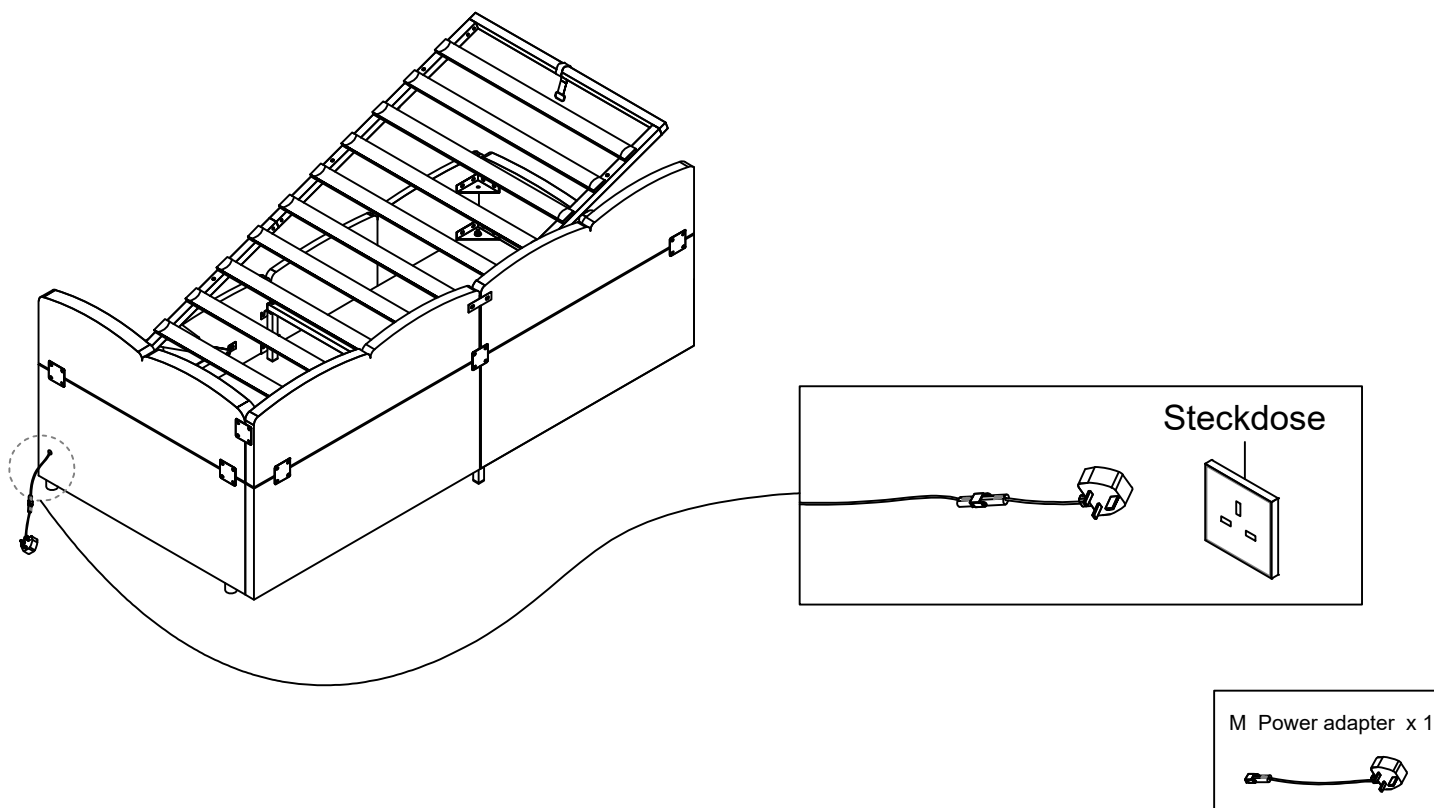

Step 16:

Every thing is finished now, please enjoy your bed.

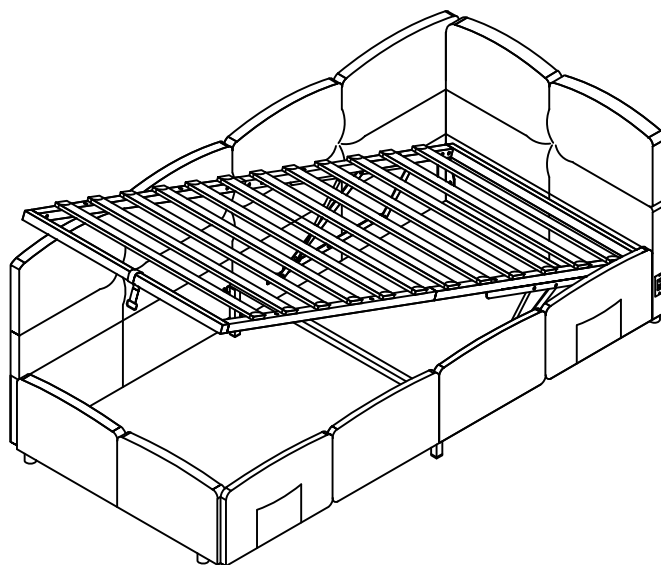

Question: What to do if the slat frame is tilted?

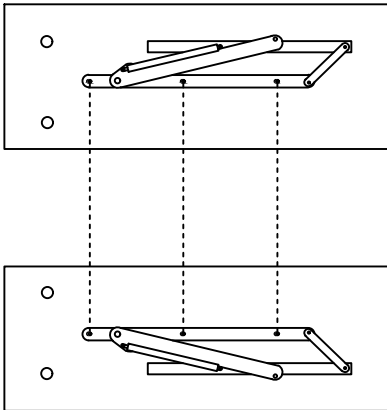

Answer:

The hole on the hydraulic rod is oval. Please make sure that the installation positions on the left and right sides are the same. If you accidentally install one side of the hydraulic rod in the front and the other side in the back, the slat frame will be crooked and you will need to disassemble it and reinstall it.

Das Loch an der Hydraulikstange ist oval. Bitte stellen Sie sicher, dass die Einbaupositionen auf der linken und rechten Seite gleich sind. Wenn Sie versehentlich eine Seite der Hydraulikstange vorne und die andere Seite hinten einbauen, kann dies zu Problemen führen. Der Rahmen der Hydraulikstange ist schief und Sie müssen sie zerlegen und neu installieren.

Question: What to do if the hydraulic system fails to press down?

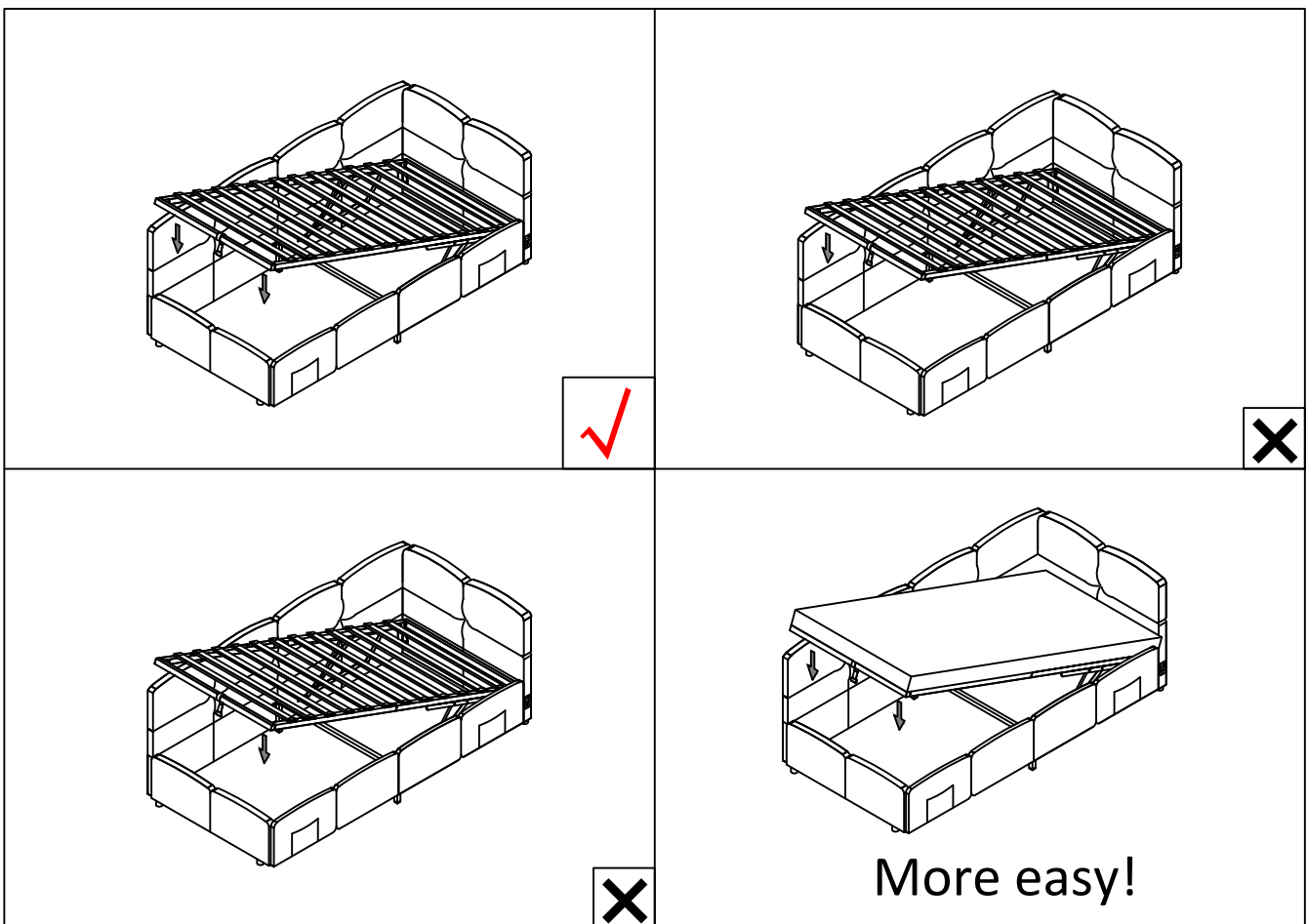

Answer:

When turning off the hydraulic pressure, make sure that the pressure point is at the position indicated by the arrow. Place your hand at the pressure point.

If you place the mattress on a slatted frame, it will be easier to turn off the hydraulic pressure. Please try it.

Do not press only on the left side or only on the right side, as this will damage the hydraulic system.

Stellen Sie beim Abschalten des Hydraulikdrucks sicher, dass sich der Druckpunkt dort befindet, wo der Pfeil anzeigt. Legen Sie Ihre Hände auf die Druckpunkte.

Wenn Sie die Matratze auf einen Lattenrost legen, lässt sich der hydraulische Druck leichter abstellen. Bitte probieren Sie es aus.

Drücken Sie nicht nur auf die linke oder nur die rechte Seite, da dies zu Schäden am Hydrauliksystem führen kann.

Importer	COMHARBOR LIMITED
Add	Unit C,Swift Point, Cosford Lane, Rugby, CV21 1PY,GB
Email/URL	harborcomhar@gmail.com
Manufacturer	Guangdong Zhangong Electric Technology Co., Ltd.
Add	402 Chuangye building,8-28,Shaqi community Central Road,Xingqiao street Bao'an District,Shenzhen
Email/URL	3001054261@qq.com
Product identification	ZG-20250720-0203
Made In	China
	COMHARBOR LIMITED Unit C,Swift Point, Cosford Lane, Rugby, CV21 1PY,GB harborcomhar@gmail.com

**UK
CA**



Product Name:Furniture Power Distribution Units
Model:ZG-JJY-1UK to 8UK
Rated voltage:AC220-250V
Rated frequency:50-60HZ
Power:10W

Registration No. : WTN23D07163421R2
Reference No. : WTN23D07163421R2Z
Applicant : Guangdong Zhangong Electrical Technology Co., LTD
Address : 701, Building 29, Zhifu Garden, Xingtan Town,
Shunde District, Foshan City
Manufacturer : The same as above
Address : The same as above
Product : See attachment
Model No. : See attachment
Technical data : See attachment



Test Standards:

BS 1363-2: 2016+A1:2018
BS EN IEC 62368-1:2020/A11:2020

The above product has been tested by us with the listed standards and found in compliance with the Electrical Equipment (Safety) Regulations 2016 of United Kingdom (S.I. 2016 No.1101). It is possible to use UKCA marking to demonstrate the compliance with the regulations.

Audio/video, information and communication technology equipment- Part 1: Safety requirements

13 A plugs, socket outlets, adaptors and connection units-Part 2: Specification for 13 A switched and unswitched socket outlets

The referred test report(s) show that the product complies with standard(s) recognized as giving presumption of compliance with the essential requirements in the above mentioned UK regulations. Other relevant UK regulations have to be observed.

After preparation of the necessary technical documentation as well as the declaration of conformity, the UKCA marking as shown below can be affixed on the equipment under the sole responsibility of the manufacturer.



Deval Qin
Manager: Deval Qin
Date: 2024-12-10

The statement is based on a single evaluation of the sample of above mentioned product. It does not imply an assessment of the whole production.

Waltek Testing Group Co., Ltd.

Hotline: 400-840-2288

E-mail: info@waltek.com.cn

[Http://www.waltek.com.cn](http://www.waltek.com.cn)

Ver.03. 26.09.2024, WALTEK is registered trademark. Utilisation and application requires prior approval.

Attachment

Model list



Reference No.:WTN23DD07163421R2Z

Product name	Model name	differences	
Furniture socket	ZG-JJY-1	13A 250V AC , USB output: 5V 2A 10W	1-position socket without switch and USB
	ZG-JJY-1UK		1-bit socket with switch and USB
	ZG-JJY-2		2-position socket without switch and USB
	ZG-JJY-2UK		2-bit socket with switch and USB
	ZG-JJY-3		3-position socket without switch and USB
	ZG-JJY-3UK		3-bit socket with switch and USB
	ZG-JJY-4		4-position socket without switch and USB
	ZG-JJY-4UK		4-bit socket with switch and USB
	ZG-JJY-5		5-position socket without switch and USB
	ZG-JJY-5UK		5-bit socket with switch and USB
	ZG-JJY-6		6-position socket without switch and USB
	ZG-JJY-6UK		6-bit socket with switch and USB
	ZG-JJY-7		7-position socket without switch and USB
	ZG-JJY-7UK		7-bit socket with switch and USB
ZG-JJY-8	8-position socket without switch and USB		
ZG-JJY-8UK	8-bit socket with switch and USB		

====End of Attachment=====

Waltek Testing Group Co., Ltd.

Hotline:400-840-2288

E-mail:info@waltek.com.cn

Http://www.waltek.com.cn

Ver.03. 26.09.2024, WALTEK is registered trademark. Utilisation and application requires prior approval.