

## Parts List For Headboard

### HEADBOARD CARTON

(6) HEADBOARD POST -2 (PRE-INSTALLED)

(7) HEADBOARD PANEL-1

### HARDWARE BAG

(1) 1/4-20 X 1 1/2" FLAT ALLEN HEAD SCREW-8 (2 PRE-INSTALLED)

(2) 1/4" ID LOCK WASHER-8 (2 PRE-INSTALLED)

(3) 1/4" ID X 5/8" OD FLAT METAL WASHER-12 (2 PRE-INSTALLED)

(4) 1/4-20 HEX NUT-4

(5) 4MM X 80MM ALLEN WRENCH-1

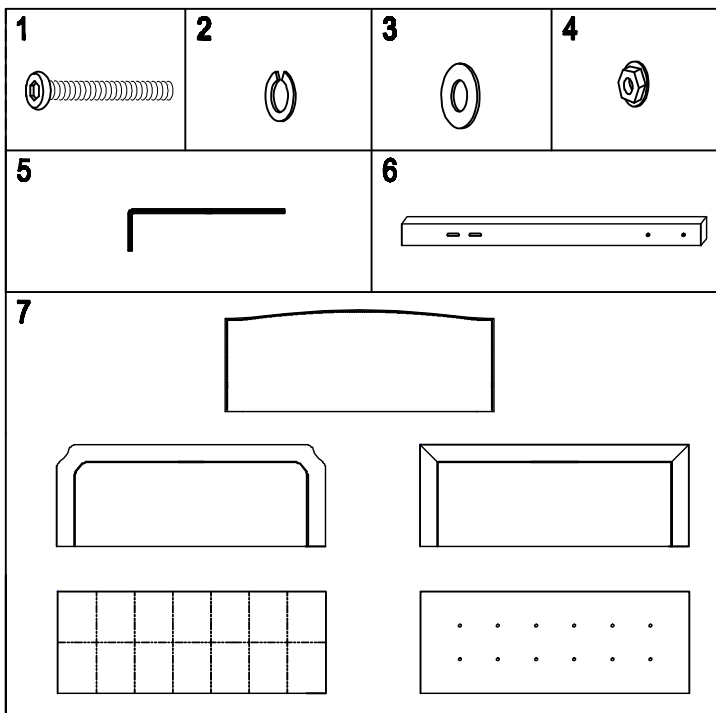

### THREADED INSERT LOCATION

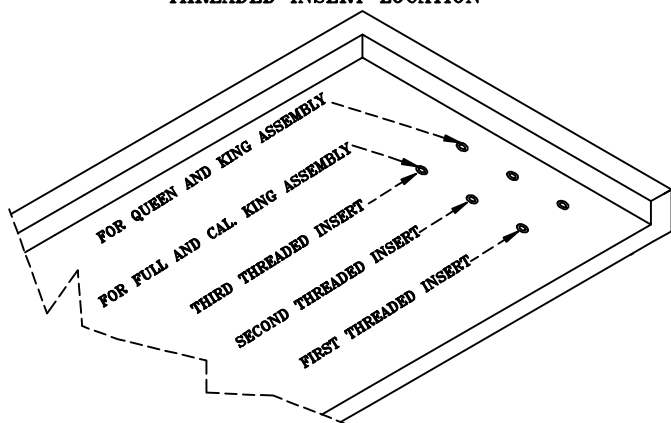

SAVE ALL PACKAGING MATERIALS UNTIL PRODUCT IS FULLY ASSEMBLED. HARDWARE AND SMALL PIECES MAY NOT BE SEEN AND COULD BE ACCIDENTALLY DISCARDED WITH PACKAGING MATERIALS.

## Instruction Sheet

### STEP 1- Assembly of Headboard Panel

- Place headboard panel (7) face down on flat clean surface. SEE FIGURE 1
- Use Allen Wrench (5) to remove headboard post (6) pre-installed on headboard panel (7).

NOTE : Use first and second threaded inserts on back panel for highest headboard setting or second and third threaded inserts for lowest headboard setting. Use inside threaded inserts for Full and Cal. King sizes or outside threaded inserts for Twin/Queen and King headboard assembly.

FIGURE 1

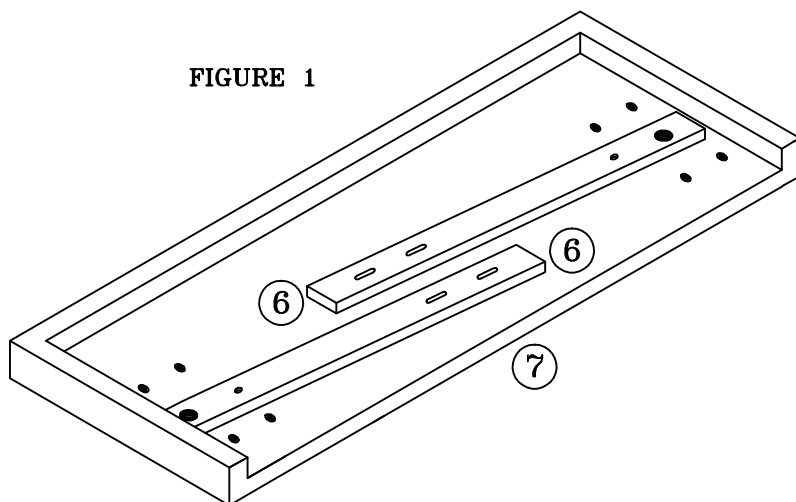

FOR ASSISTANCE IN ASSEMBLY ONLY OF THIS PRODUCT. CALL OUR HELP DESK AT . PLEASE HAVE THE STYLE NUMBER AVAILABLE BEFORE YOU CALL. (STYLE # OR NAME CAN BE FOUND ON PACKING CARTON OR SALES RECEIPT.) OUR PRODUCT IS INSPECTED TO ENSURE IT IS IN GOOD CONDITION. IF YOUR FURNITURE APPEARS TO HAVE BEEN DAMAGED IN SHIPMENT OR YOU ARE IN NEED OF REPLACEMENT PARTS PLEASE CONTACT THE DEALER FROM WHOM YOU PURCHASED THE PRODUCT.

## Instruction Sheet

### STEP 2- Assembly of FULL and CAL. KING Headboard.

- Align pilot holes on headboard post (6) with threaded insert on headboard panel (7).  
SEE FIGURE 2
- Secure headboard post (6) with screw (1), lock washer (2) and flat metal washer (3).
- Use Allen wrench (5) to tighten screws (1) completely.

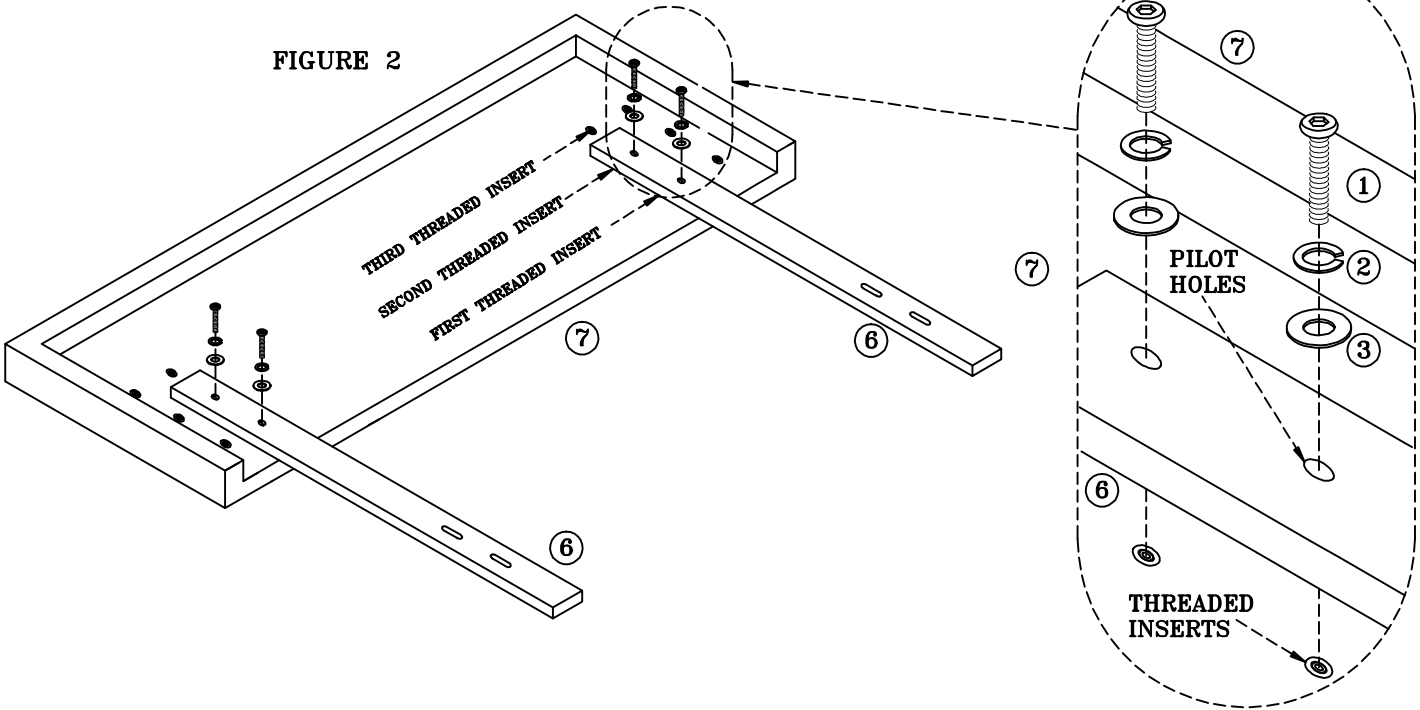

### STEP 3- Assembly of TWIN/QUEEN and KING Headboard.

- Align pilot holes on headboard post (6) with threaded insert on headboard panel (7).  
SEE FIGURE 3
- Secure headboard post (6) with screw (1), lock washer (2) and flat metal washer (3).
- Use Allen wrench (5) to tighten screws (1) completely.

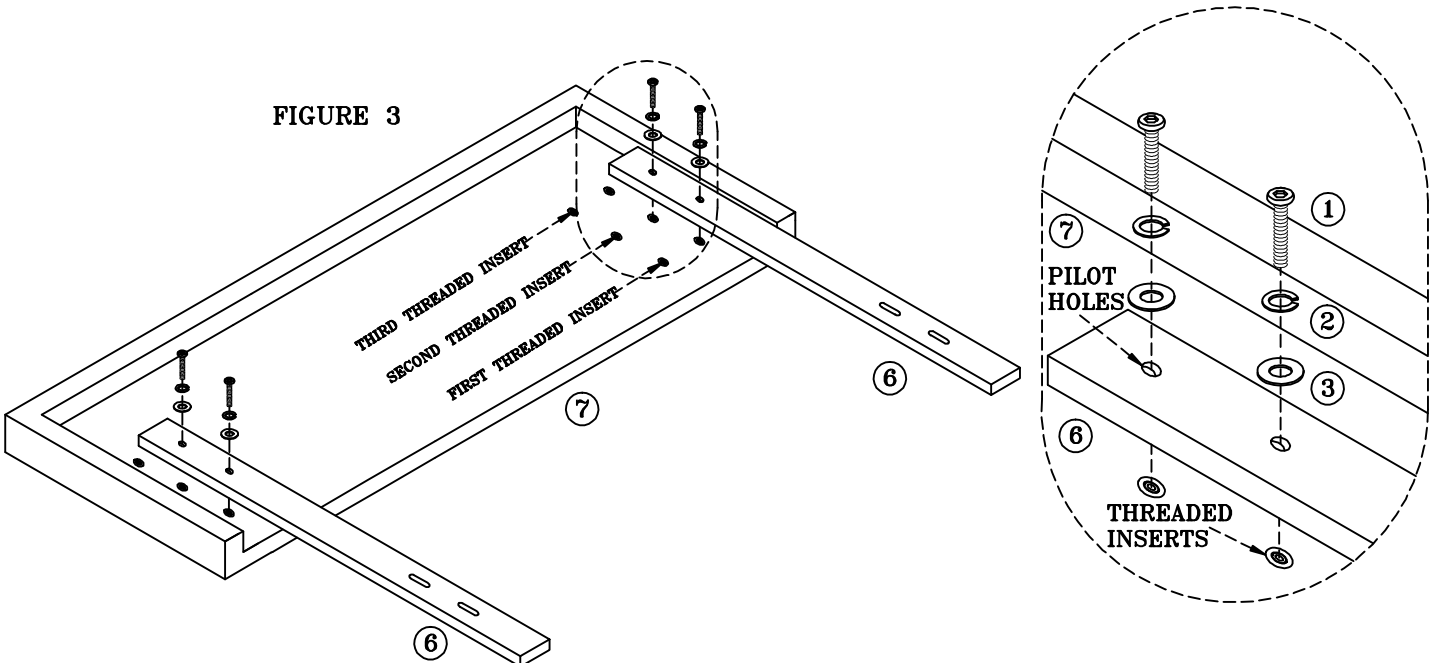

## Instruction Sheet

### STEP 4—Headboard Assembly.

- Place headboard and frame in desired location in room.
- Align pilot holes on headboard post (6) with holes on headboard frame bracket. SEE FIGURE 4
- Secure headboard post (6) with screw (1),lock washer (2);flat metal washer (3) and hex nut (4).
- Tighten screw (1) with Allen wrench (5).

FIGURE 4

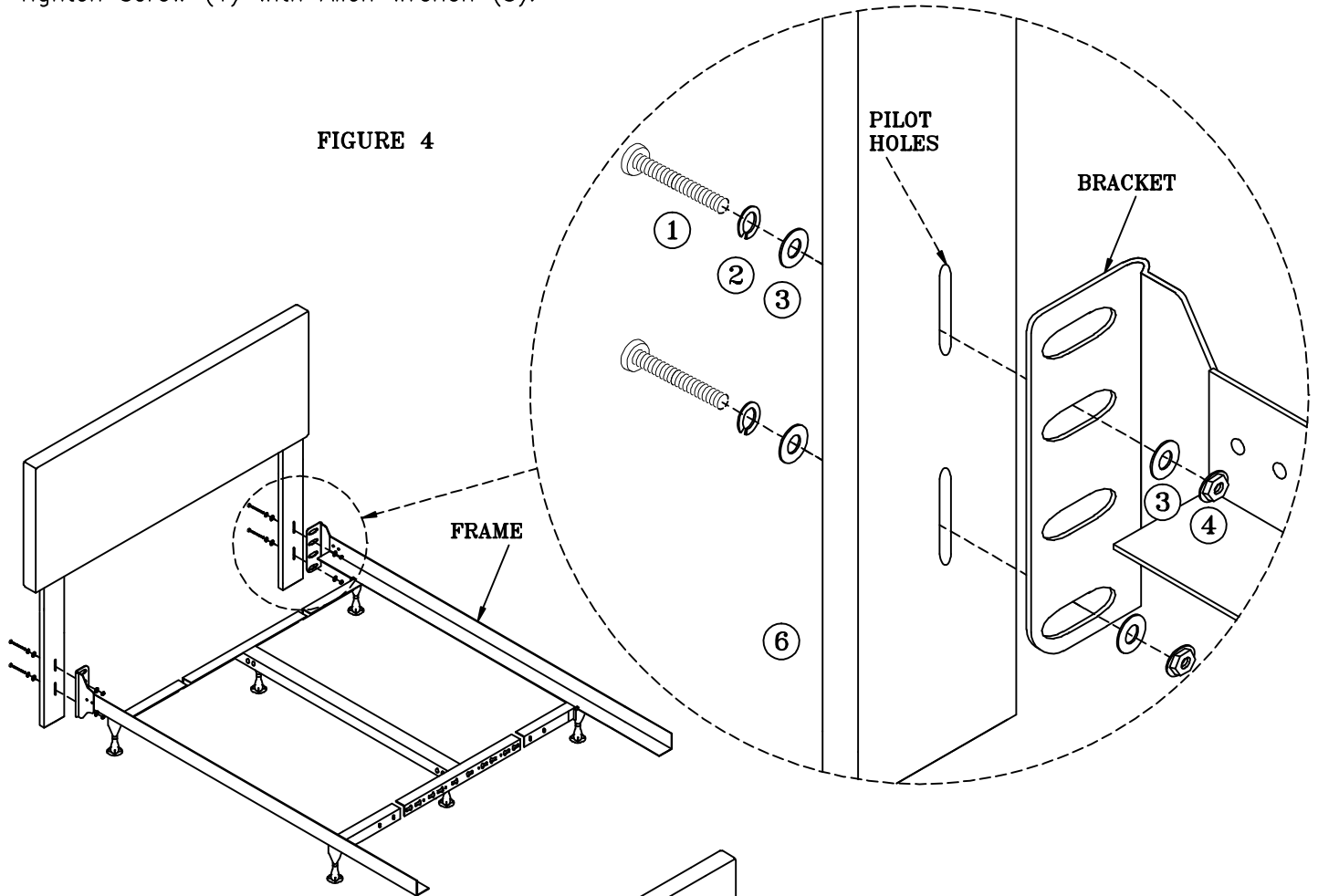

HEADBOARD FULLY ASSEMBLY

