

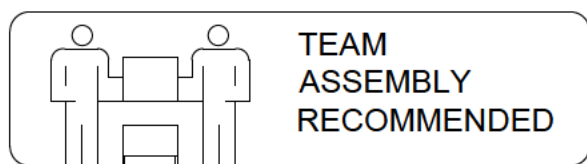

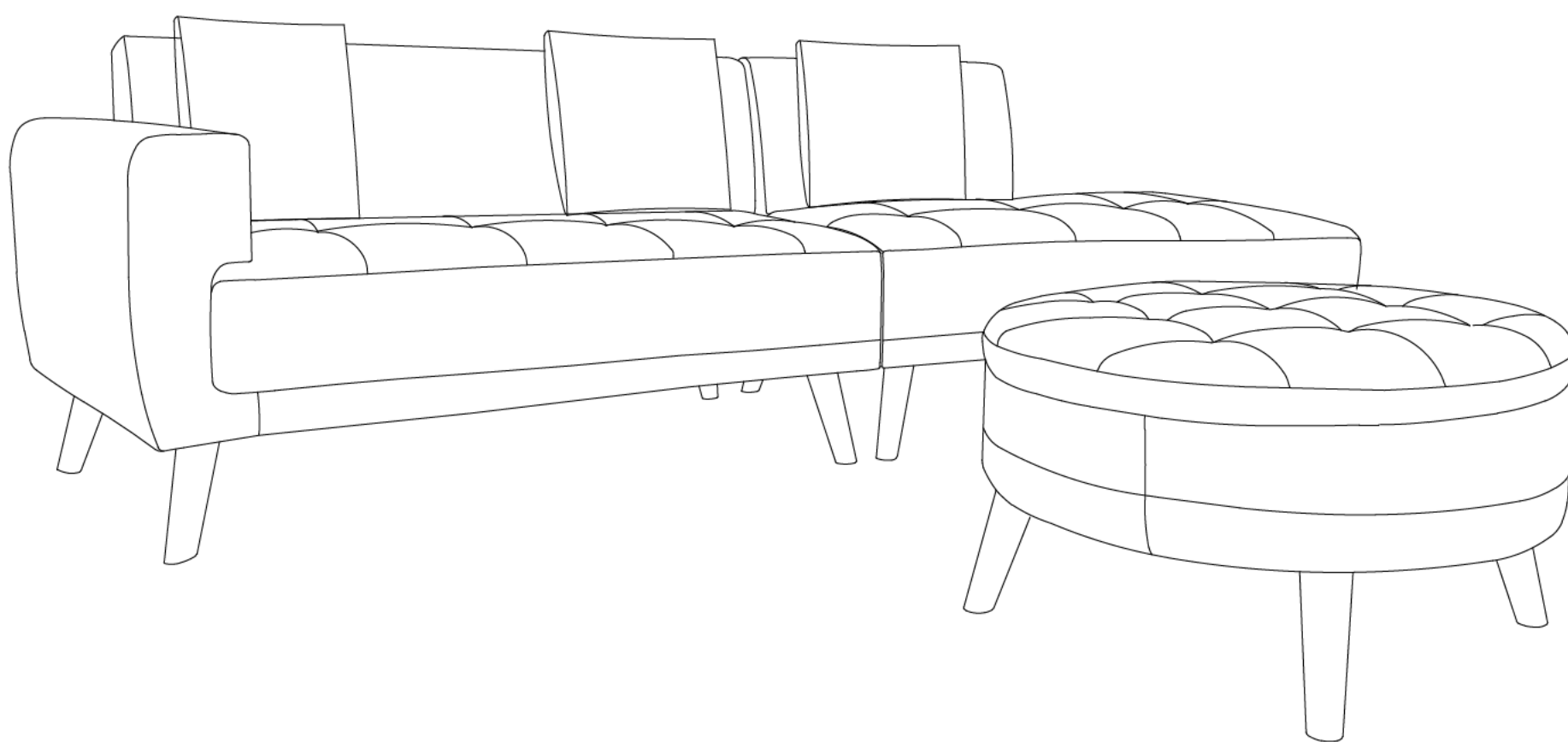

INSTRUCTION

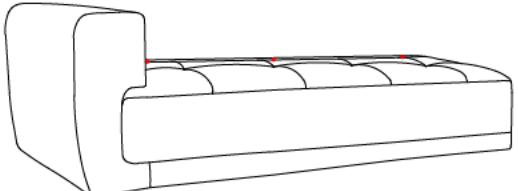
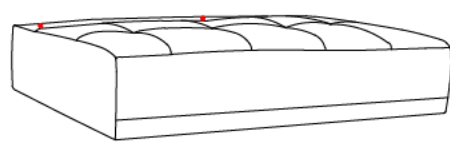
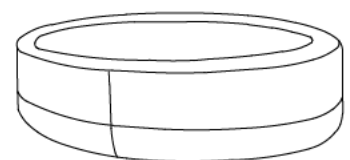

SOFA

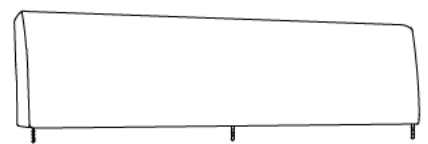
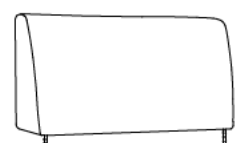

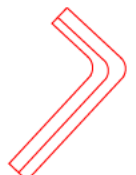
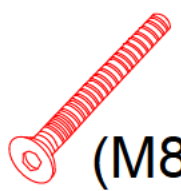
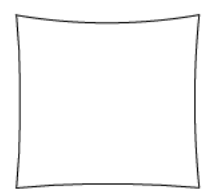

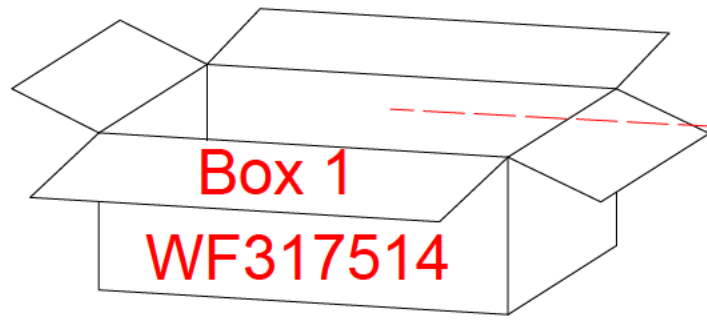

PARTS LIST

NO	PART	DECS	QTY
(A)		SEAT CUSHION	1pc
(B)		SEAT CUSHION	1pc
(C)		OTTOMAN	1pc
(D)		OTTOMAN	1pc
(E)		COUCH BACK	1pc
(F)		COUCH BACK	1pc
(G)		LEGS	12pc
(H)	 (M8x 17mm)	WASHERS	12pc
(I)		L-SHAPED WRENCH	3pc
(J)	 (M8x 60mm)	SCREWS	12pc
(K)		PILLOW	3pc

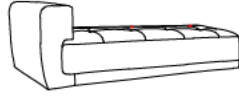
STEP 1

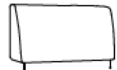
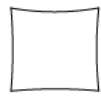
Ship by 3 boxes





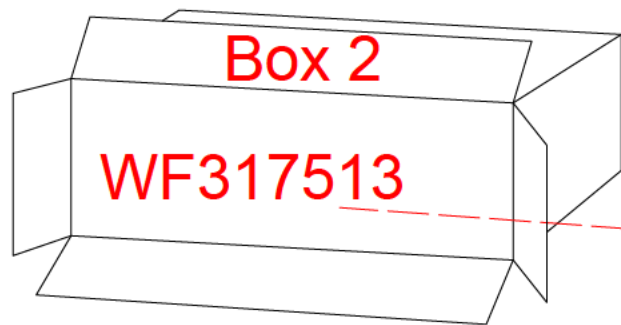

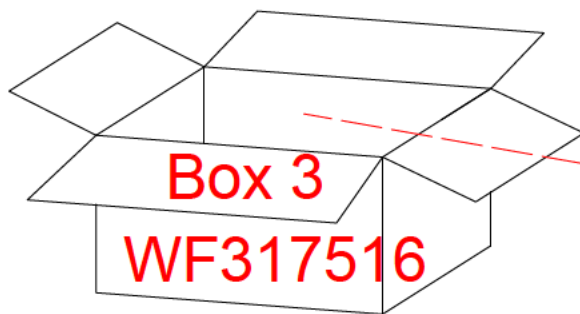

NO	PART	DECS	QTY
(A)		SEAT CUSHION	1pc
(E)		BACK	1pc
(F)		BACK	1pc
(K)		PILLOW	1pc
(G)		LEGS	8pc
(H)	 (M8x 17mm)	WASHERS	8pc
(I)		L-SHAPED WRENCH	1pc
(J)	 (M8x 60mm)	SCREWS	8pc



NO	PART	DECS	QTY
(B)		SEAT CUSHION	1pc



NO	PART	DECS	QTY
(D)		OTTOMAN	1pc
(C)		OTTOMAN	1pc
(K)		PILLOW	2pc
(G)		LEGS	4pc
(H)	 (M8x 17mm)	WASHERS	4pc
(I)		L-SHAPED WRENCH	1pc
(J)	 (M8x 60mm)	SCREWS	4pc

STEP 2

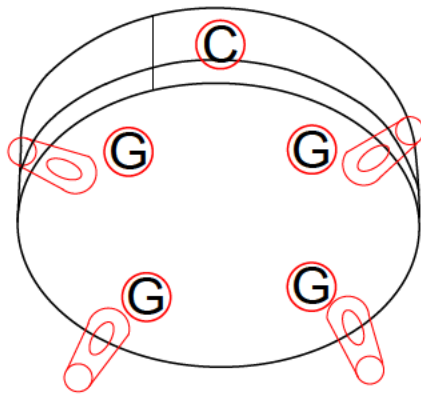
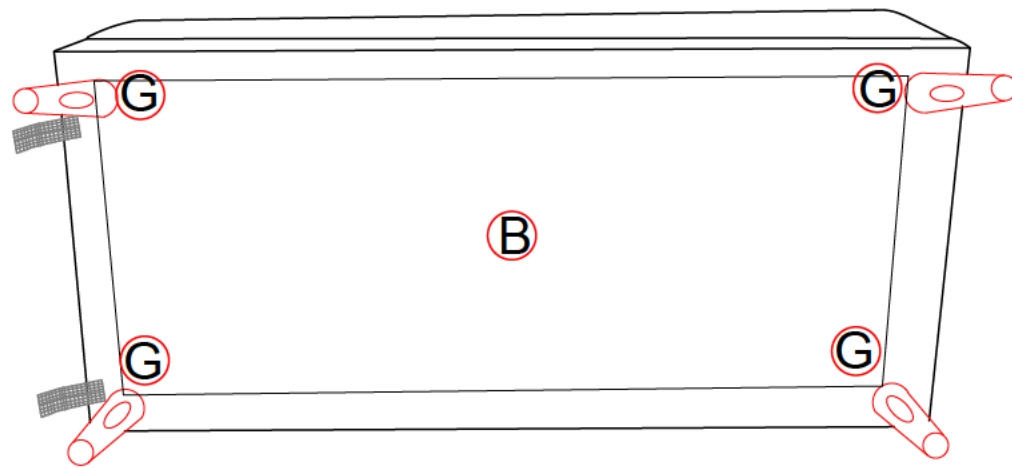
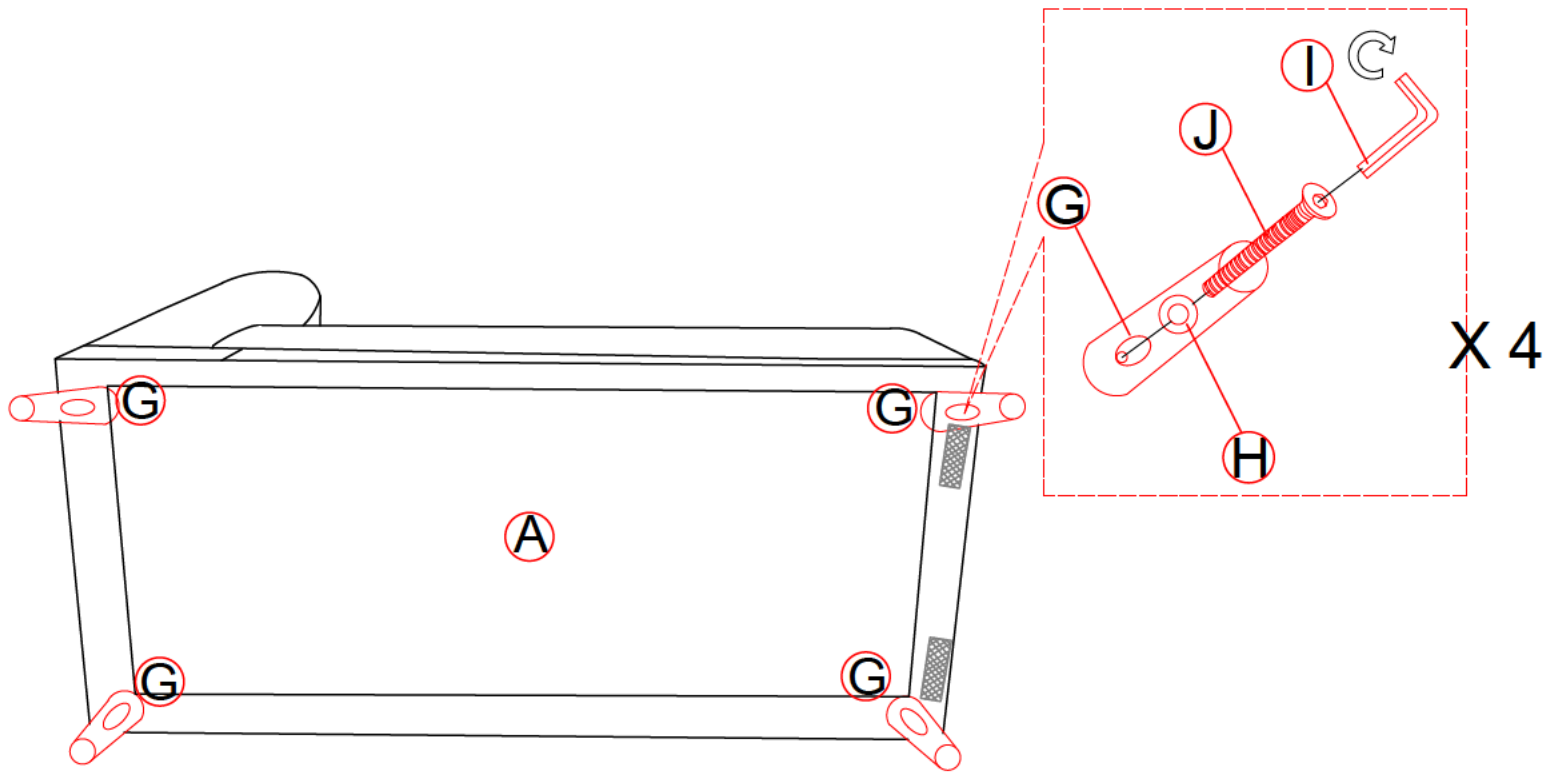

STEP 3

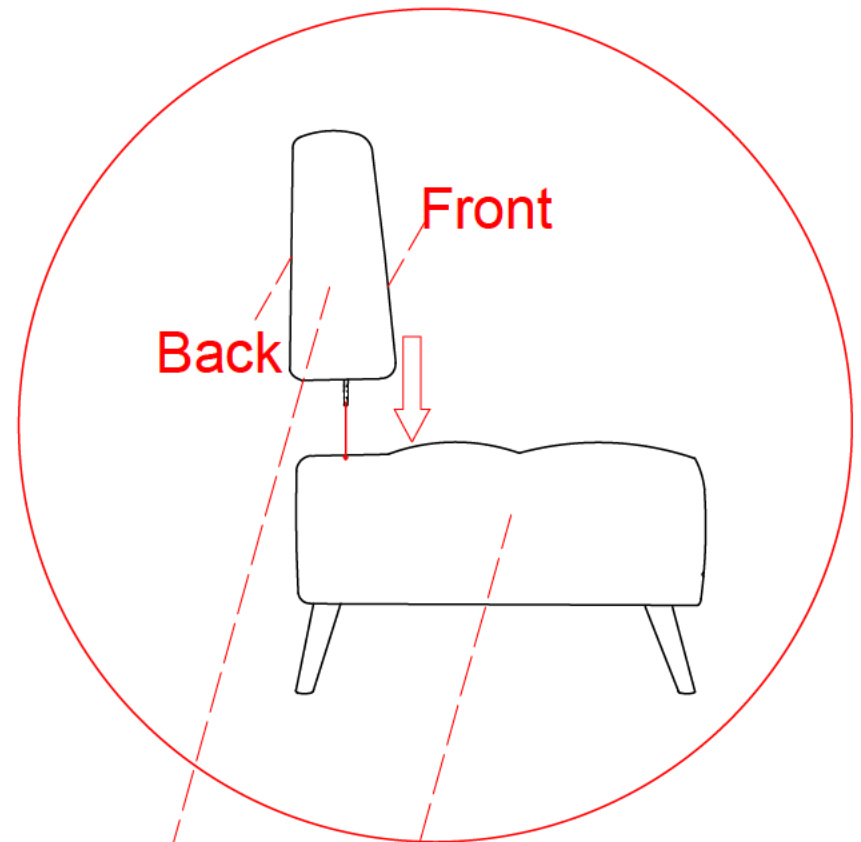
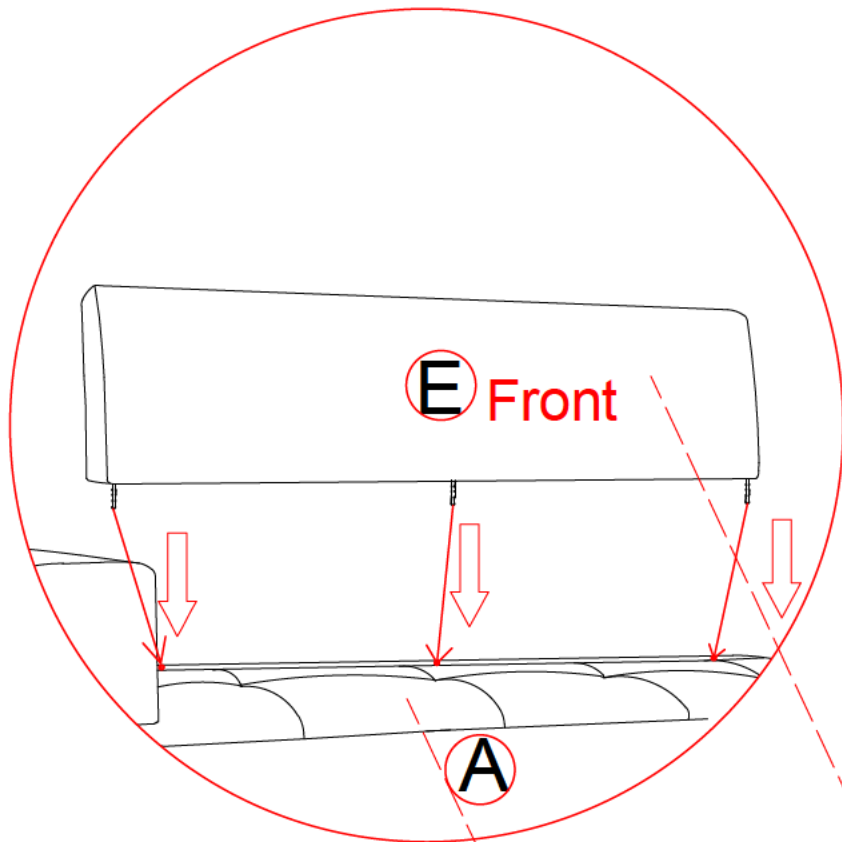

And back at the bottom of the plug into the sofa hole

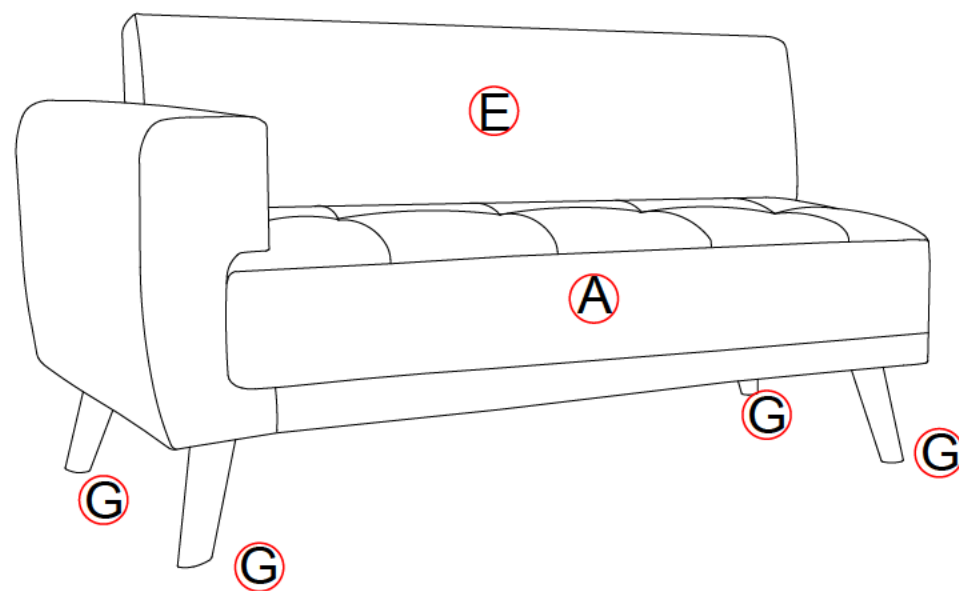
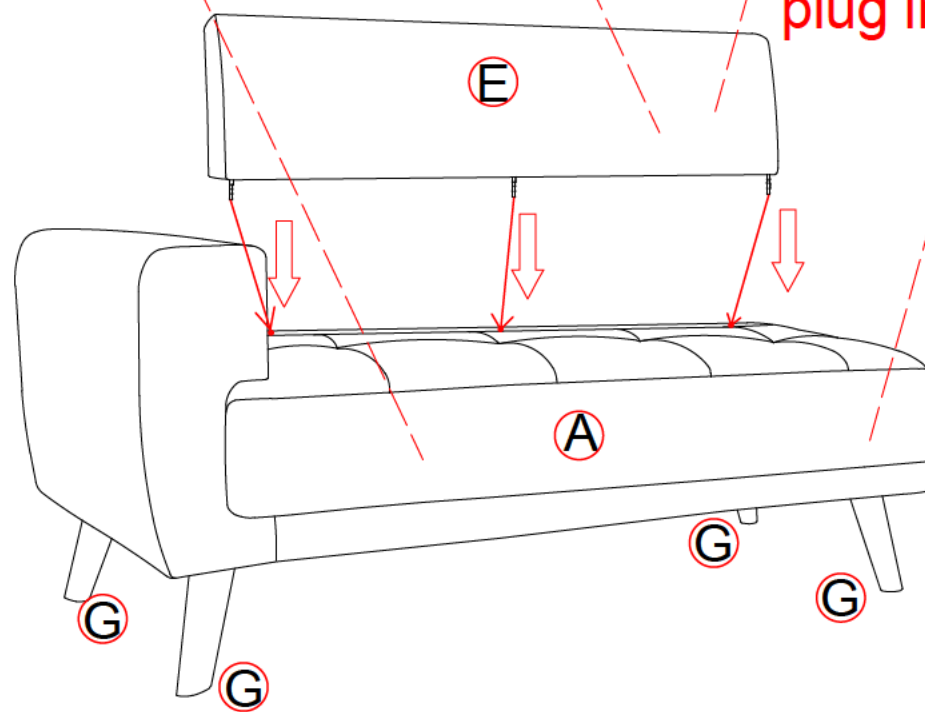

STEP 4

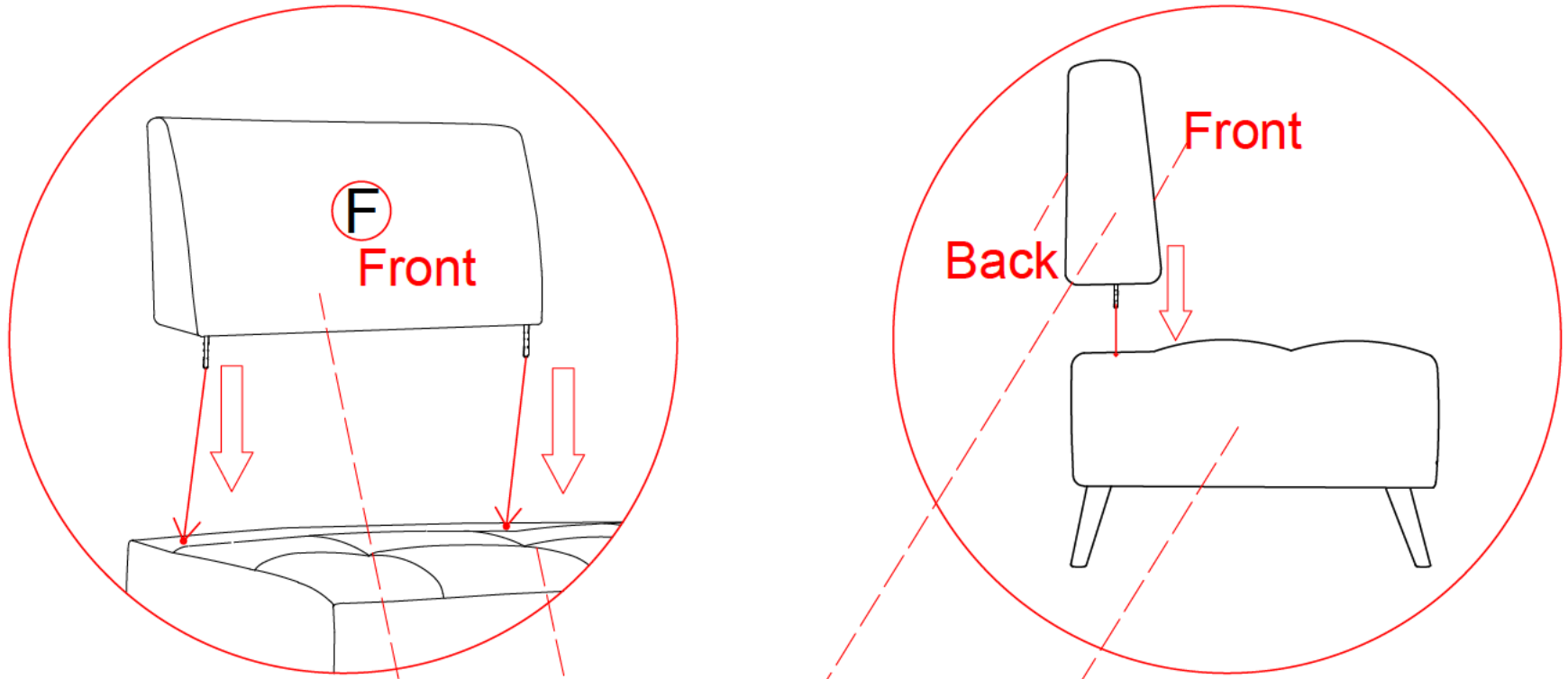

And back at the bottom of the plug into the sofa hole

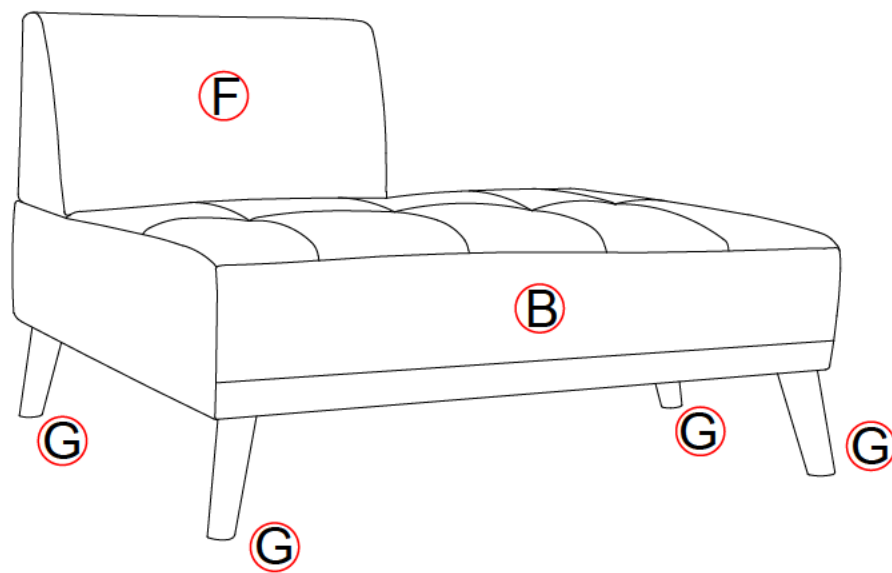
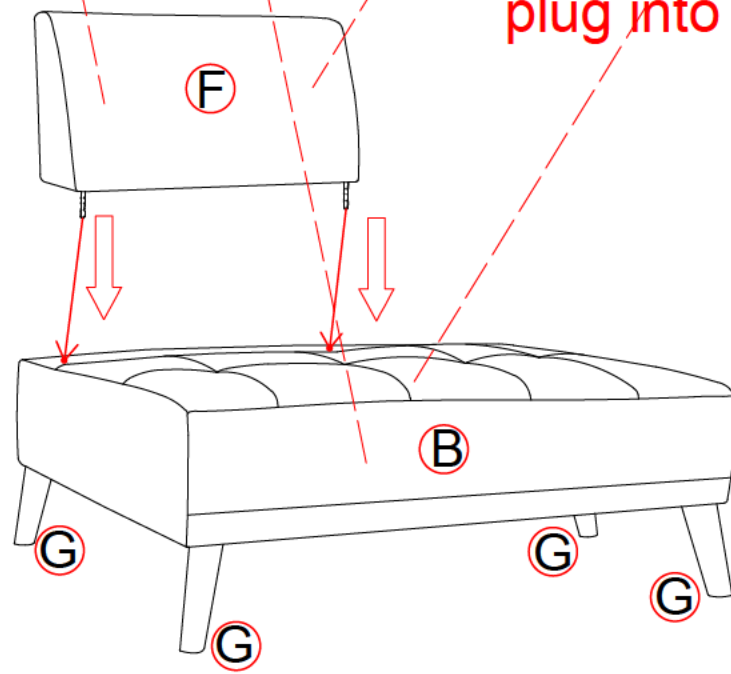

STEP 5

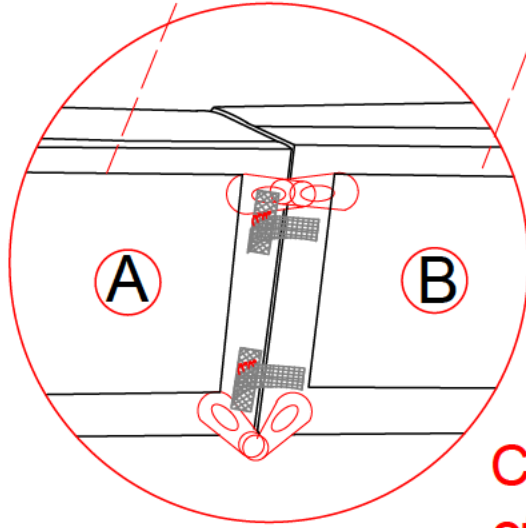
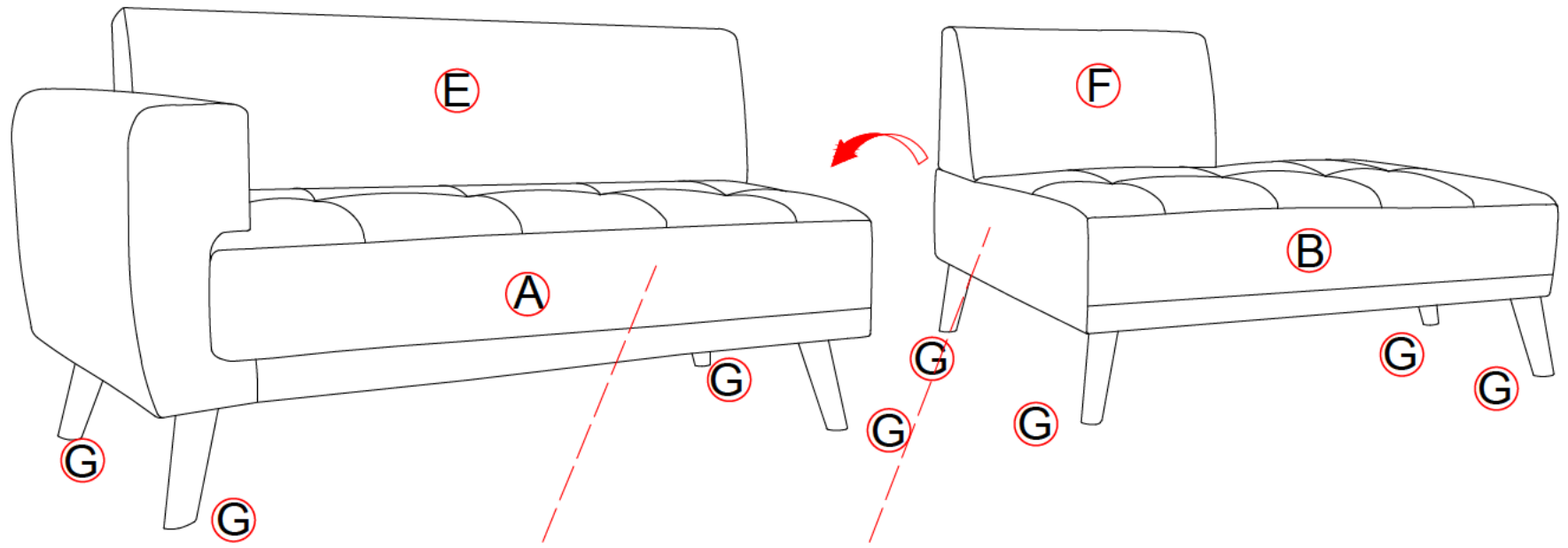

Connect the Velcro at the bottom of Sofa A & B

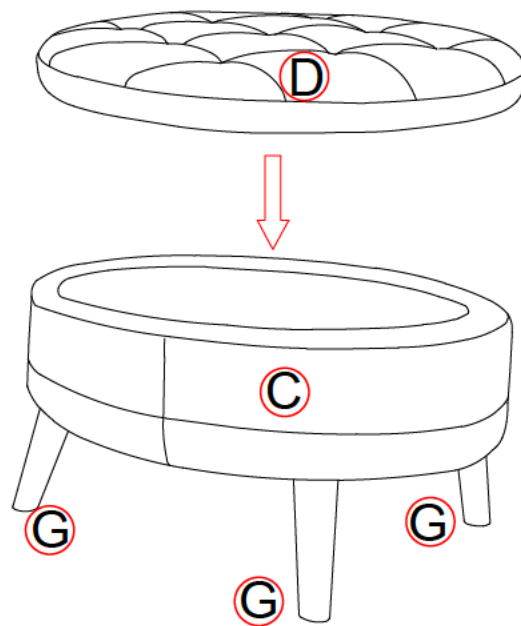

STEP 6

