

Parts and Damage Replacement Procedure

1. Please inspect your purchase immediately.
2. This procedure covers product purchased from an authorized Reseller and was received in its originally sealed carton.

**A COPY OF YOUR PURCHASE RECEIPT OR INVOICE MUST BE ATTACHED TO THIS ORDER FORM.
NO ORDERS WILL BE PROCESSED WITHOUT PROOF OF PURCHASE.**





NAME: _____
ADDRESS: _____ (No Post Office Boxes)
CITY: _____ STATE: _____ ZIP: _____
PHONE: _____ FAX: _____
EMAIL: _____

REASON FOR REPLACEMENT/PLEASE CHECK APPROPRIATE BOX.

- () Damaged /scratched, cracked, broken, crushed, etc.
- () Mechanical malfunction/ drawer glides, swivel mechanisms, lid stays, etc.
- () Missing pieces
- () Unfinished surface
- () Wrong color
- () Other

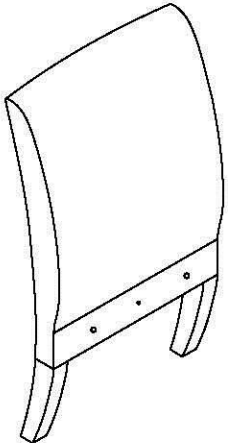
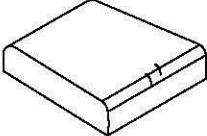
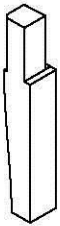
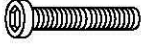
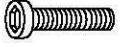
IF MORE THAN ONE MODEL NUMBER IS LISTED ABOVE, PLEASE SPECIFY THE EXACT MODEL NUMBER OF YOUR ITEM IN THE SPACE PROVIDED BELOW.

Model Number	Part Letter Code	Quantity

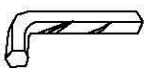
<p>Ax1</p> 	<p>Bx1</p> 	<p>Cx2</p> 	<p>Dx4</p>  <p>5/16" x 100mm</p>
			<p>Ex4</p>  <p>5/16" x 70mm</p>
	<p>Fx2</p>  <p>5/16" x 60mm</p>	<p>Gx10</p> 	<p>Hx10</p> 
	<p>Jx1</p> 	<p>Please find leg and hardware pack inside the dust cover underneath seat cushion!</p>	

- ⚠ NOTE: UNIT SHOULD BE ASSEMBLED BY TWO OR MORE PEOPLE. DO NOT TIGHTEN ANY BOLTS UNTIL ALL BOLTS HAVE BEEN STARTED!
- ⚠ NOTA: ¡ESTA UNIDAD DEBE SER ARMADA POR 2 O MAS PERSONAS! NO APRIETE NINGUN PERNO HASTA QUE TODOS ESTEN EN SU LUGAR!
- ⚠ REMARQUE: LE MEUBLE DOIT ETRE ASSEMBLÉ PAR DEUX PERSONNES OU PLUS. NE BLOQUER AUCUNE VIS TANT QUE VOUS N'AVEZ PAS COMMENCE A TOUTES LES DEMARRER!
- ⚠ 注意：产品应由两个或者两个以上的人员组装。在产品组装过程中，不要锁紧螺栓！

①

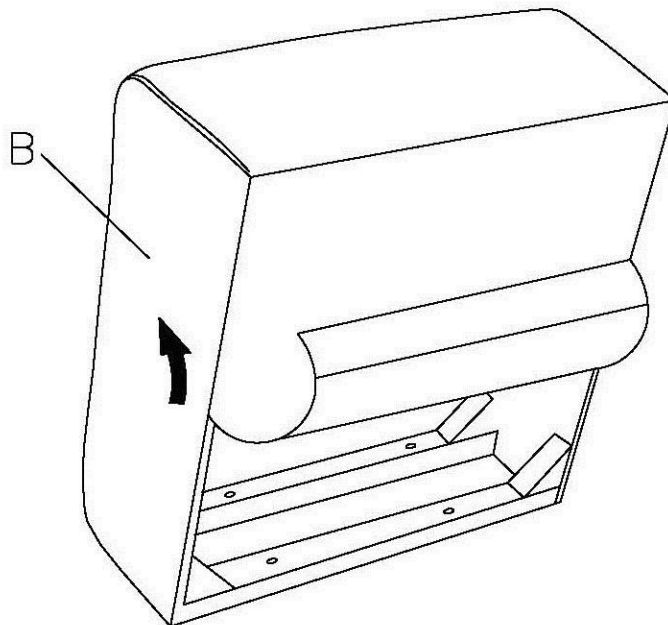

2

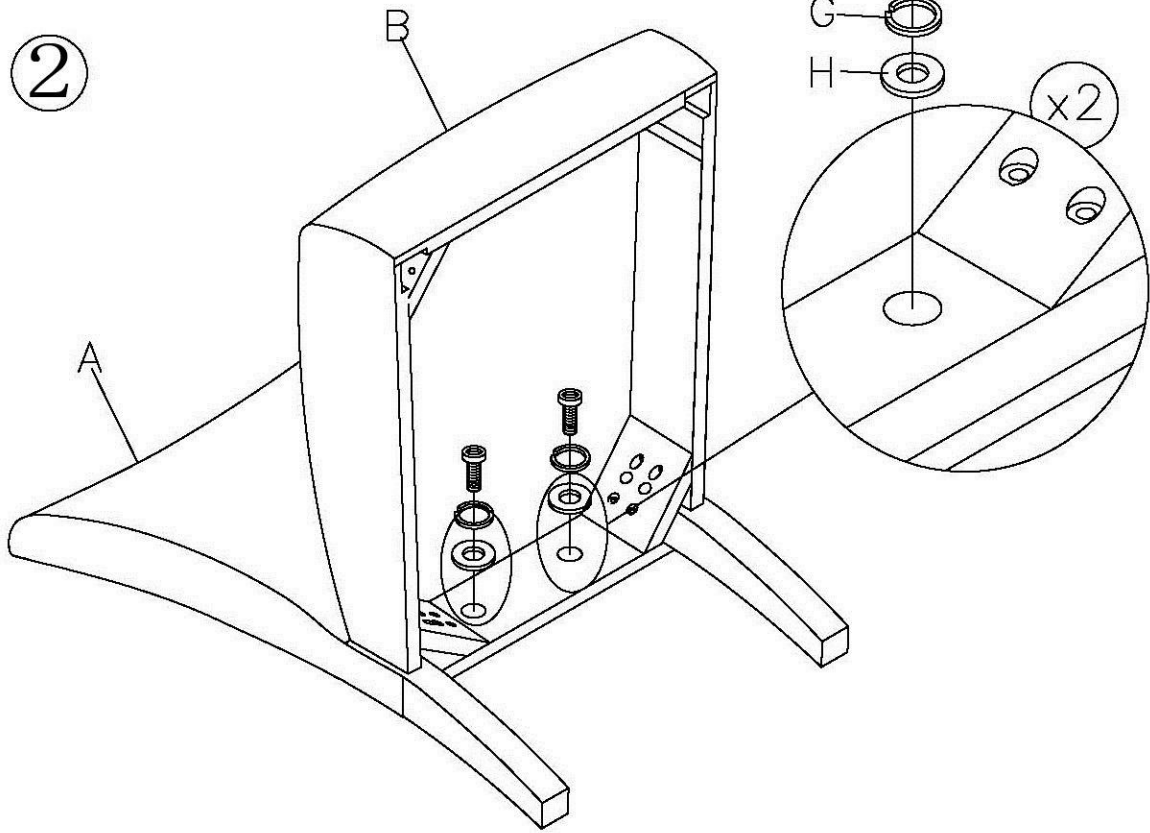

3

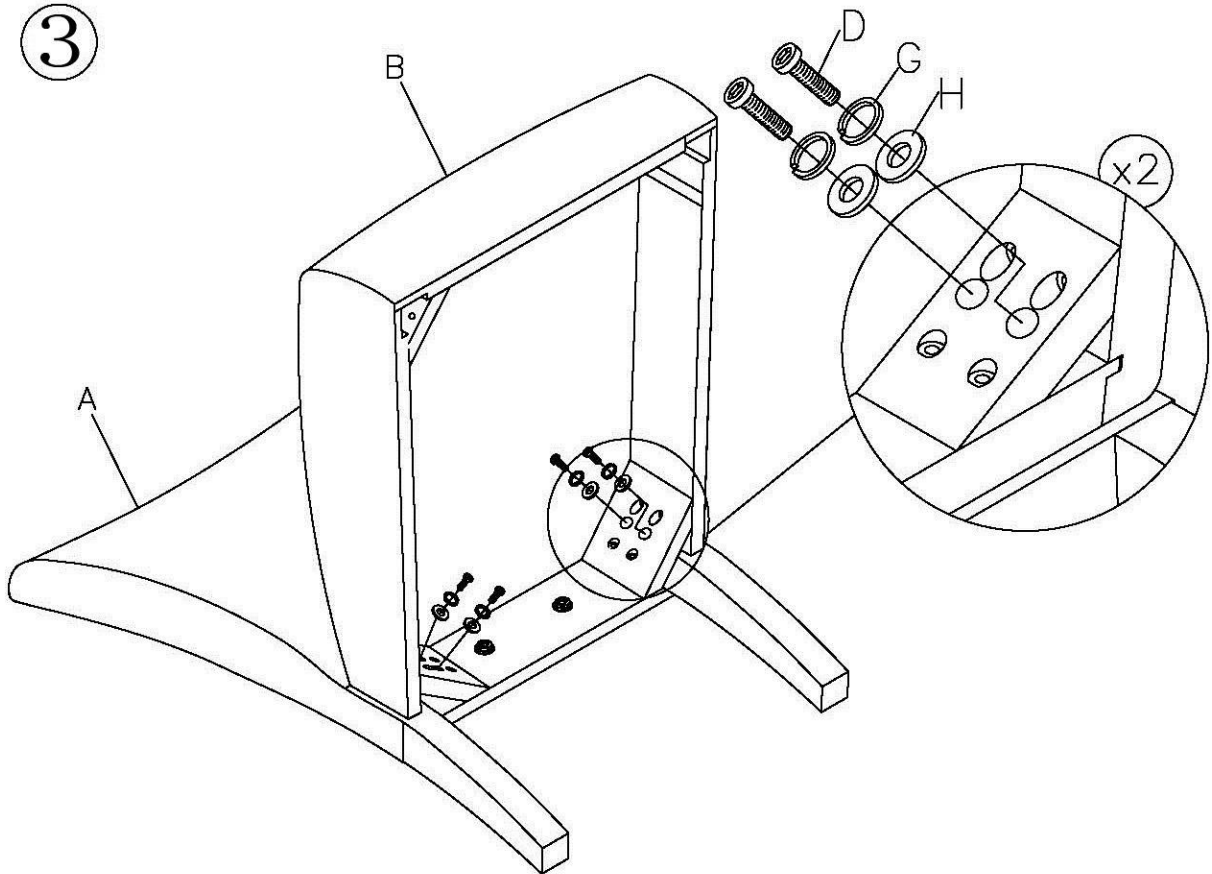

4

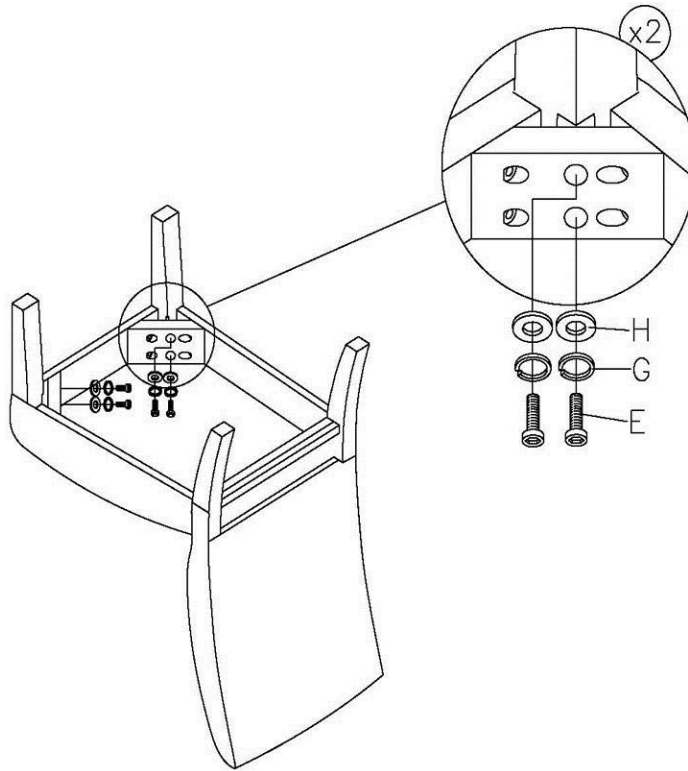

5

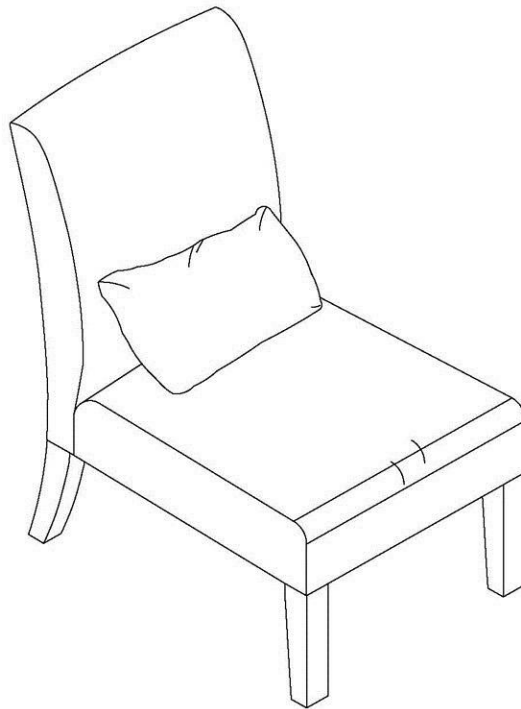

NOTE: Level the chair and tighten all bolts with the allen wrench.

NOTA: Nivele la silla y aprete todos los pernos con la llave allen.

REMARQUE: Mettez la chaise droite et serrez tous les boulons avec les clés allen.

注意：如果发现椅子不稳，请用内六角扳手拧紧所有螺杆。