

Harbor Bench Assembly Guide

Harbor Bench Assembly- 44" Dining Height, Counter Height
66" Dining Height, Counter Height



Dining Height



Counter Height

Hardware Included

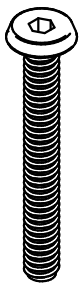

1/4"x2" Bolt
44"- x8
66"- x12

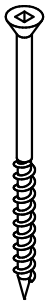

3" Buglehead
Screw x8

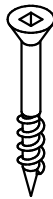

1 1/2" Buglehead
Screw x2
Does not apply
to 44" Bench



1/4" Flange Nut
44"- x8
66"- x12

Tools / Items Needed



Allen Wrench
(Included)



Tape Measure



#2 Square Drive Bit



Cordless Drill

Step 1

For 66" bench slide long bench supports through the center base assembly as shown. For 44" bench start with Step 2. Note: Place braces in the position shown!

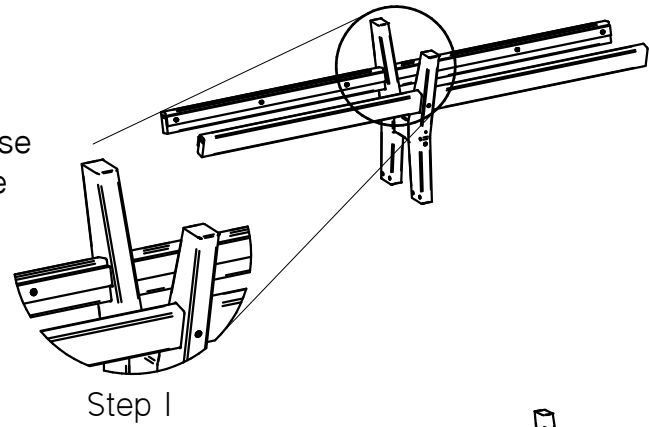

Step 2

Start by placing long bench supports in end base assembly pockets for correct placement. Fasten each support with 3" Buglehead Screws. Repeat with other end assembly.

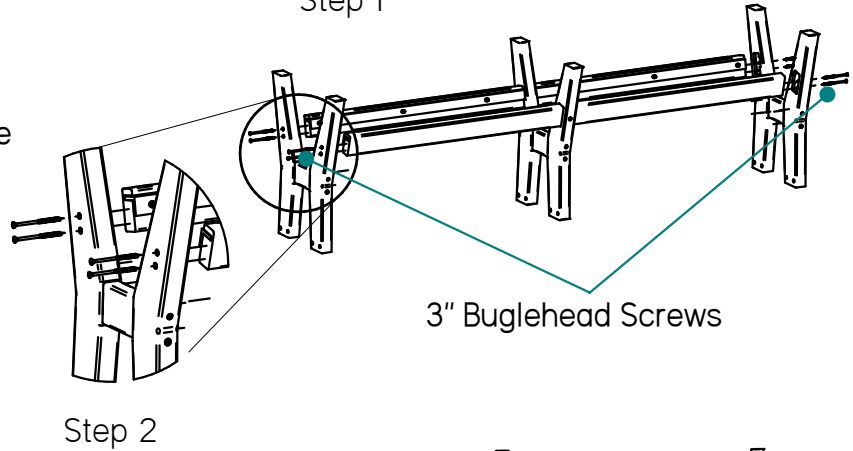

Step 3

Place assembled base on the bottom of the top. Fasten the outside base assemblies first using 1/4"x2-1/4" Bolts and 1/4" Flange Nuts. Make sure legs are on outside of aluminum angle. For 66" bench make sure center base assembly is on the outside of aluminum angle and fasten using remaining bolts.

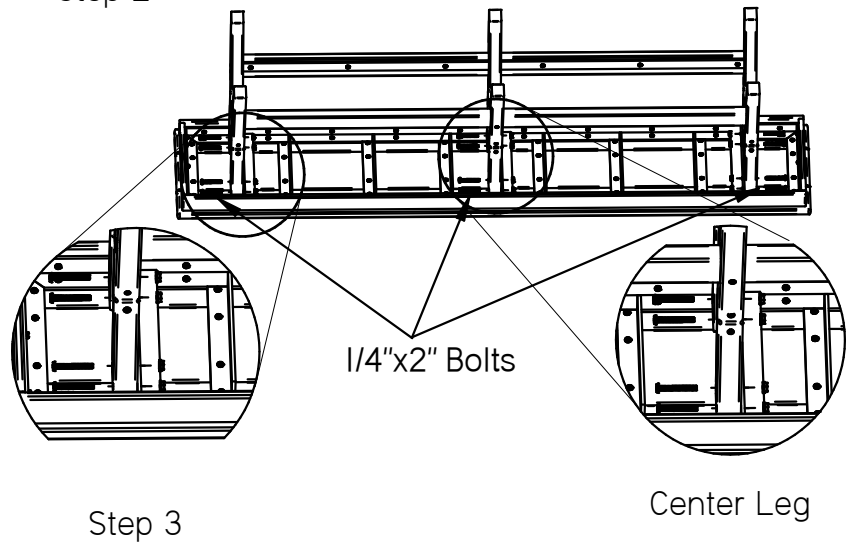

Step 4

For 66" bench only

Using a tape measure, measure 27-7/8" from the outside of outside base assembly to the outside of the center base assembly as shown and fasten center leg to long base support using 1-1/2" Buglehead Screws.

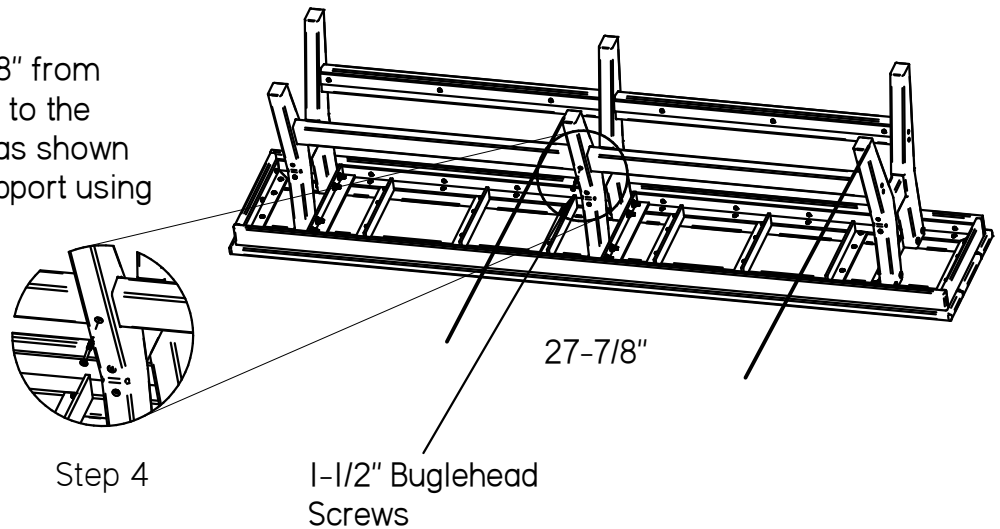

When tightening screws or lags, **DO NOT OVERTIGHTEN** to avoid stripping their hold on the material!