

ASSEMBLY INSTRUCTIONS

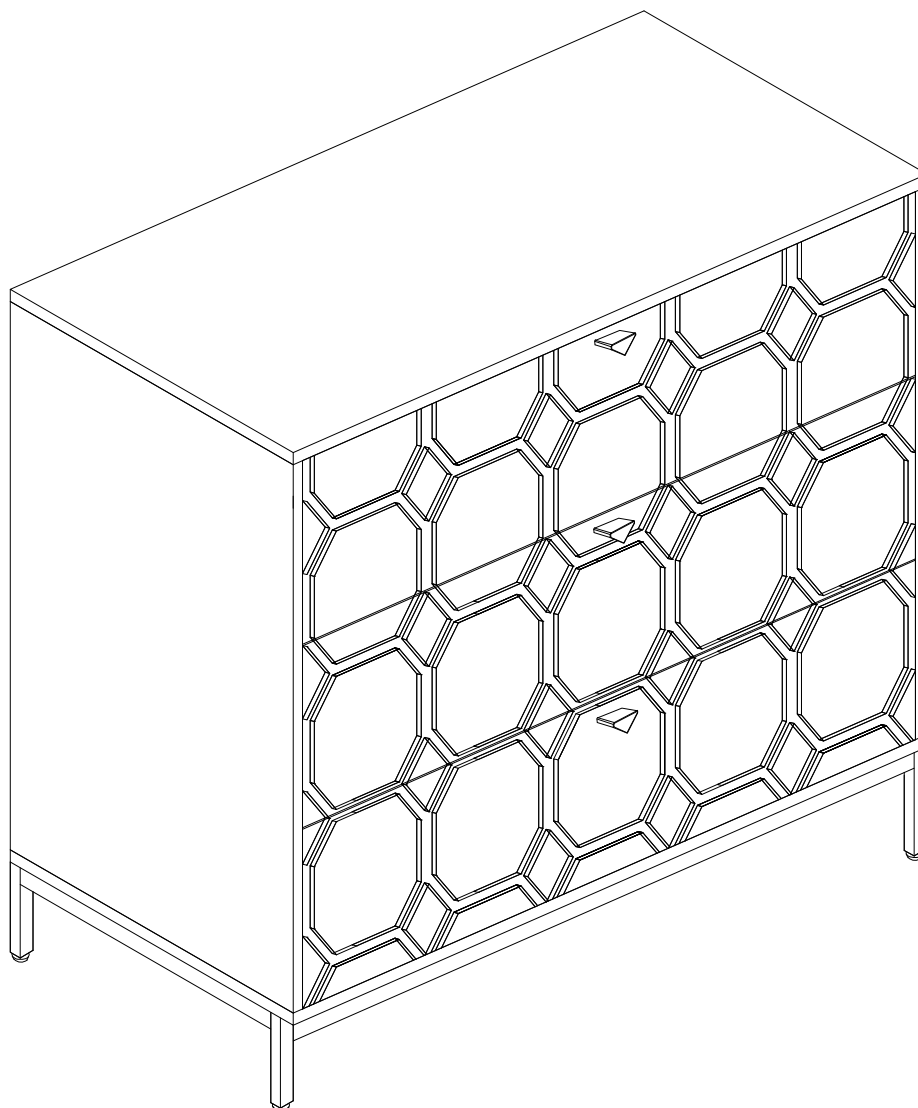

WARNING:



Risk of tipping. This unit may tip over if not secured, causing injury or death. Always secure to the wall using the safety wall strap (Part J/K/L) provided, especially in households with children or pets.

ASSEMBLY INSTRUCTIONS

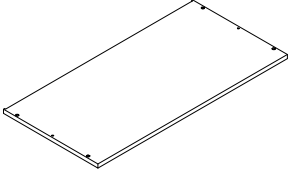
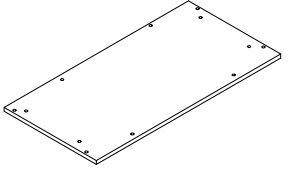
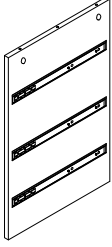
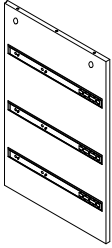
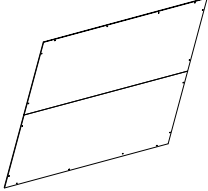
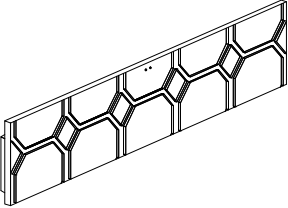
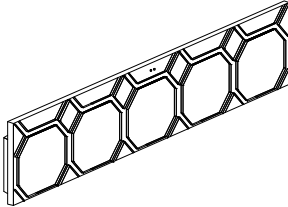
Part list:



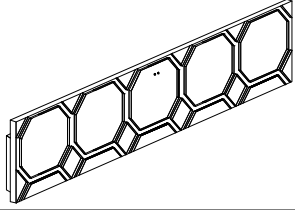

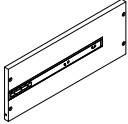
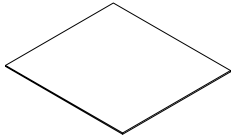
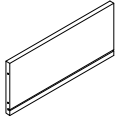
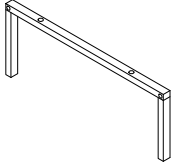
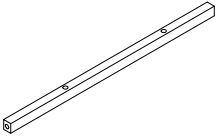

| ITEM | DESCRIPTION | PART | QTY |
|------|-----------------------|---|-----|
| 1 | Top panel |  | 1 |
| 2 | Bottom panel |  | 1 |
| 3 | Left side panel |  | 1 |
| 4 | Right side panel |  | 1 |
| 5 | Back panel |  | 1 |
| 6 | Upper drawer surface |  | 1 |
| 7 | Middle drawer surface |  | 1 |

Part list:

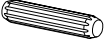





| ITEM | DESCRIPTION | PART | QTY |
|------|----------------------|---|-----|
| 8 | Lower drawer surface |  | 1 |
| 9 | Drawer left side |  | 3 |
| 10 | Drawer right side |  | 3 |
| 11 | Drawer bottom |  | 3 |
| 12 | Drawer back |  | 3 |
| 13 | Side leg |  | 2 |
| 14 | Crossbar |  | 2 |

ASSEMBLY INSTRUCTIONS

Hardware List:

| ITEM | DESCRIPTION | PART | QTY |
|------|---------------|--|-----|
| A | Wooden dowel |  Φ0.31*1.18" | 4 |
| B | Bolt |  Φ0.23*1.18" | 8 |
| C | Allen wrench |  | 1 |
| D | Handle |  | 3 |
| E | Machine screw |  Φ0.15*0.7" | 6 |
| F | Back screw |  Φ0.11*0.55" | 16 |
| G | Bolt |  Φ0.23*1.57" | 4 |

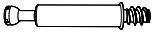
Hardware List:

| ITEM | DESCRIPTION | PART | QTY |
|------|-------------------|--|-----|
| H | Grub screw |  Φ0.15*1.37" | 28 |
| I | Safety wall strap |  | 2 |
| J | Plastic anchor |  | 2 |
| K | Mounting screw |  Φ0.15*1.57" | 2 |
| L | Washer |  | 2 |
| M | Camlock bolt |  | 4 |
| N | Camlock |  | 4 |

ASSEMBLY INSTRUCTIONS

- * Required screwdriver & mallet, not included.
- * Before discarding packing materials, please check to make sure that all parts and hardware is present.
- * Two people needed for assembly.
- * Please follow the instructions closely; Do not over-tighten screws or bolts unless specified.
- * After a few days from initial assembly, the product may adjust to the environment. Please retighten the hardware.

Guideline For Assembling of Cam Lock (M & N)

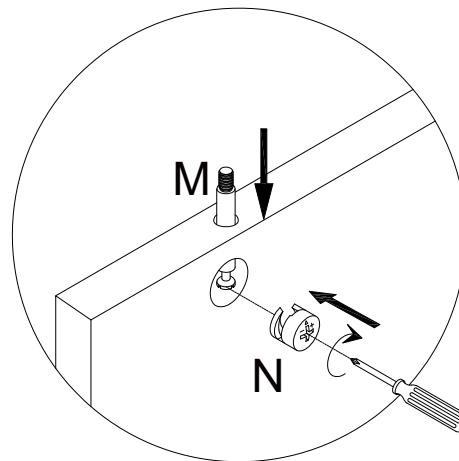
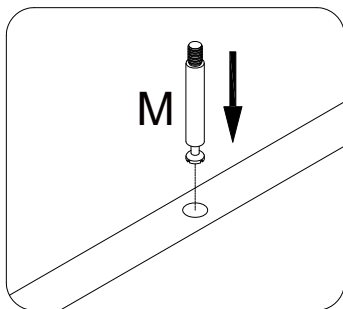



Screw camlock bolt (M) to wood part.

Do not assemble camlock (N) unless instructed.

To assemble camlock (N), ensure long side of the + is facing the bolt (M) before inserting into hole.

ASSEMBLY INSTRUCTIONS

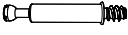
STEP 1

| | | |
|----|---|------|
| A: |  | 2PCS |
| M: |  | 4PCS |
| N: |  | 4PCS |

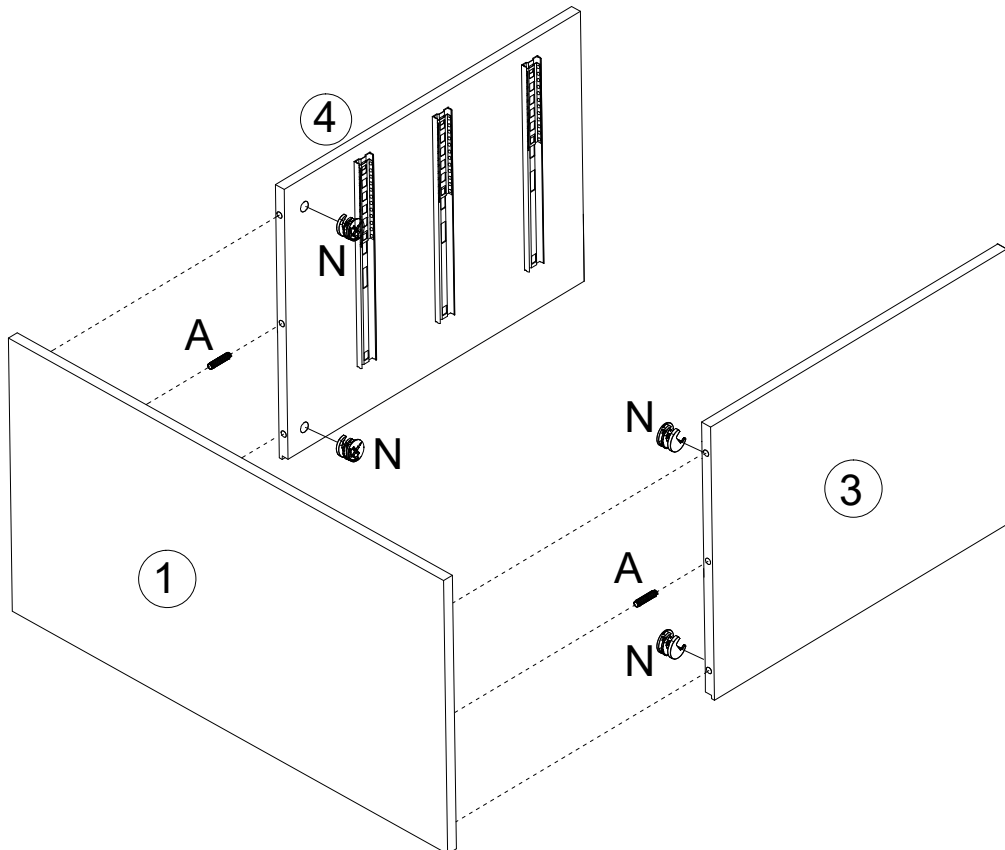
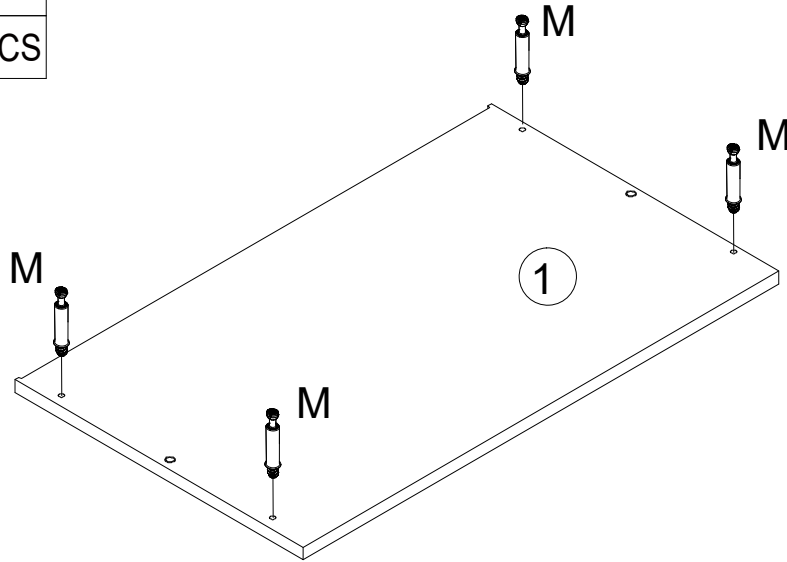

ASSEMBLY INSTRUCTIONS

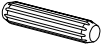

STEP 2

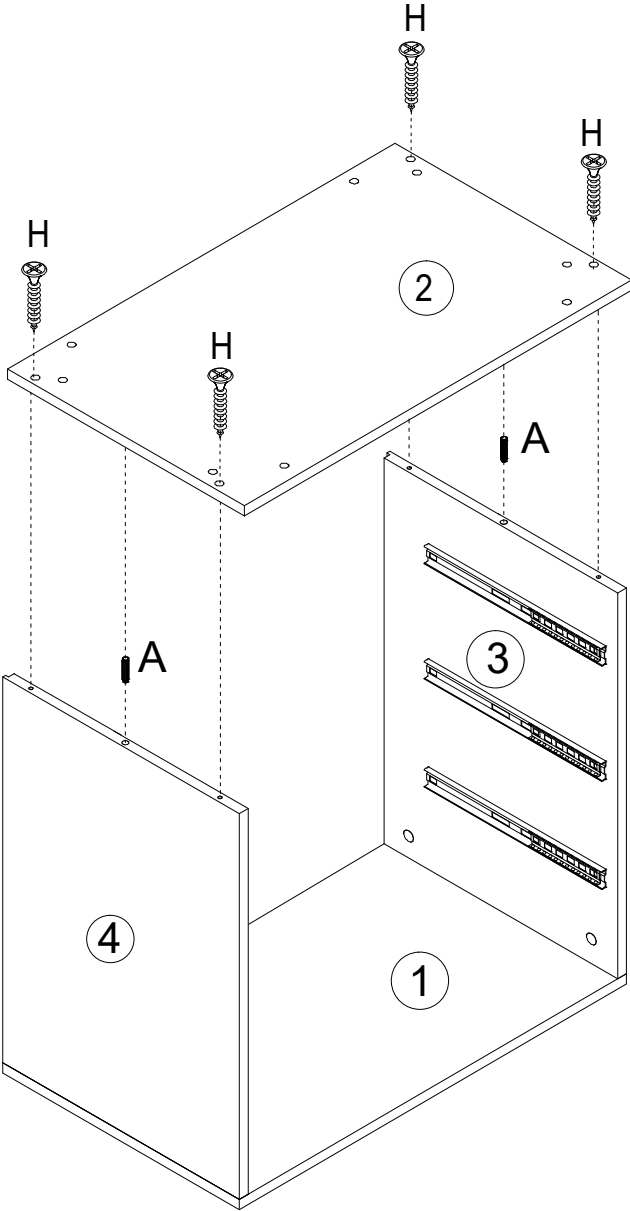
| | | |
|----|---|------|
| H: |  | 4PCS |
| A: |  | 2PCS |



ASSEMBLY INSTRUCTIONS

STEP 3

| | | |
|----|---|------|
| B: |  | 8PCS |
| C: |  | 1PC |
| G: |  | 4PCS |

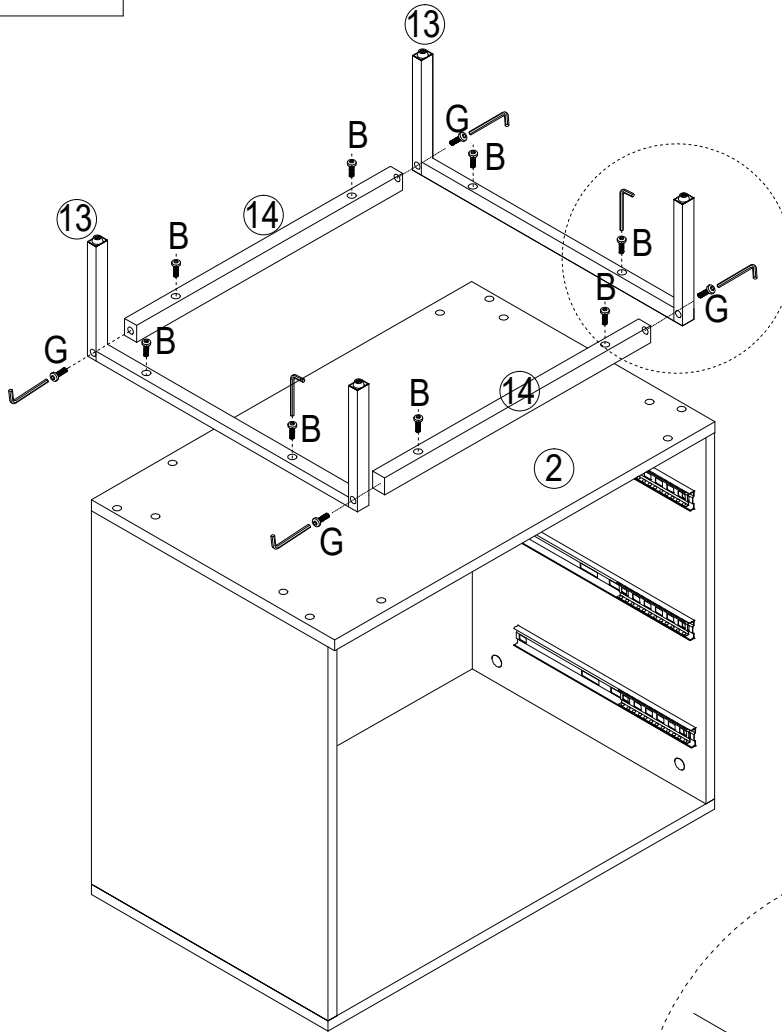

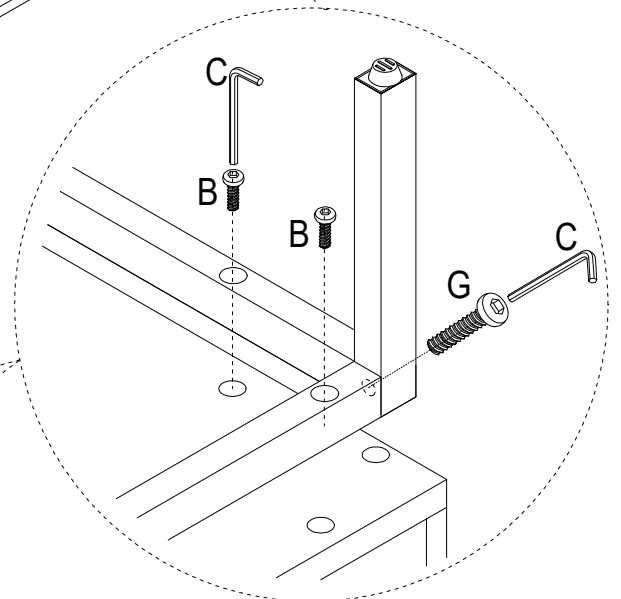

Note: Part B and Part G are screws of different lengths. Use Part B for attaching Part 13 (Side leg) to Part 14 (Crossbar), and Part G for securing Part 1 to Part 3. Using the wrong length may damage the panels.



ASSEMBLY INSTRUCTIONS

STEP 4

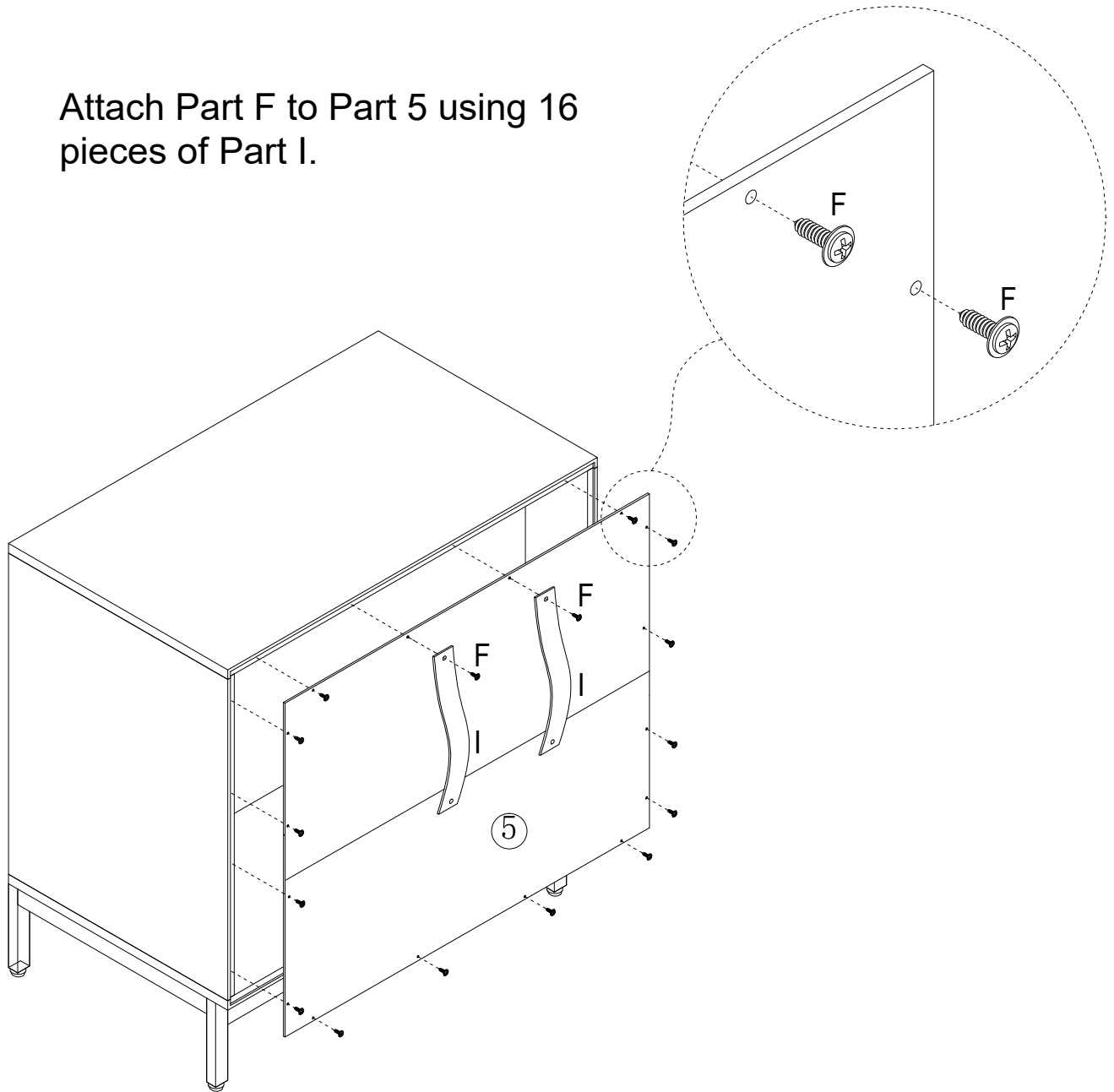

| | | |
|----|---|-------|
| F: |  | 16PCS |
| I: |  | 2PCS |

Attach Part F to Part 5 using 16 pieces of Part I.



ASSEMBLY INSTRUCTIONS

STEP 5

| | | |
|----|---|-------|
| H: |  | 24PCS |
| D: |  | 3PCS |
| E: |  | 6PCS |

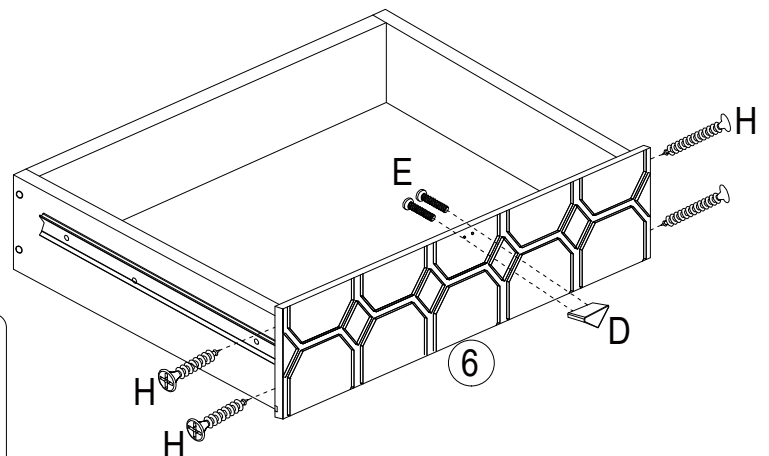
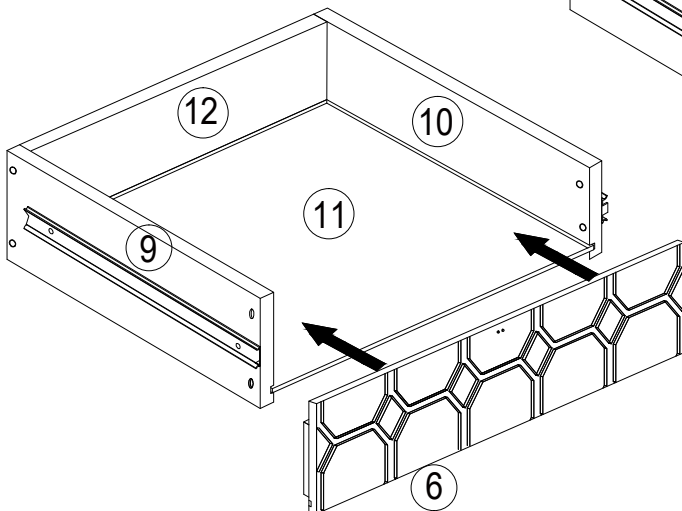
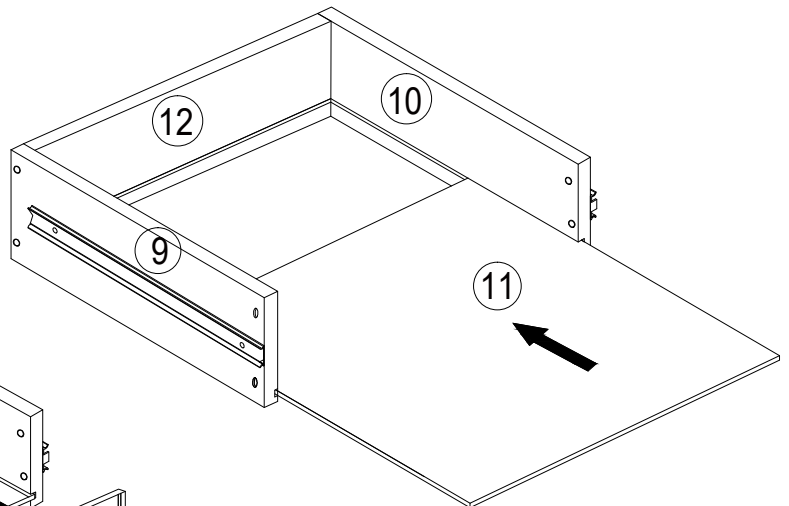
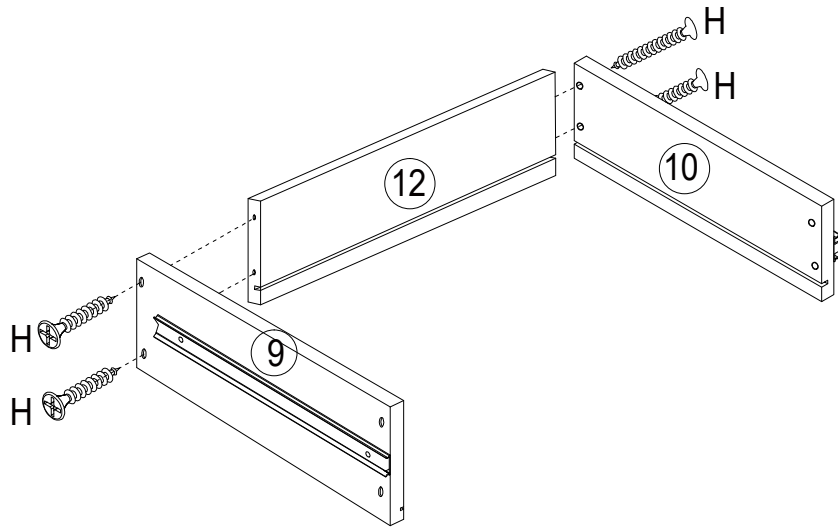

Items 6, 7, and 8 (drawers) are assembled using the same method as described above.

ASSEMBLY INSTRUCTIONS

STEP 6

Note: Place the sliding rail to the front position before sliding in

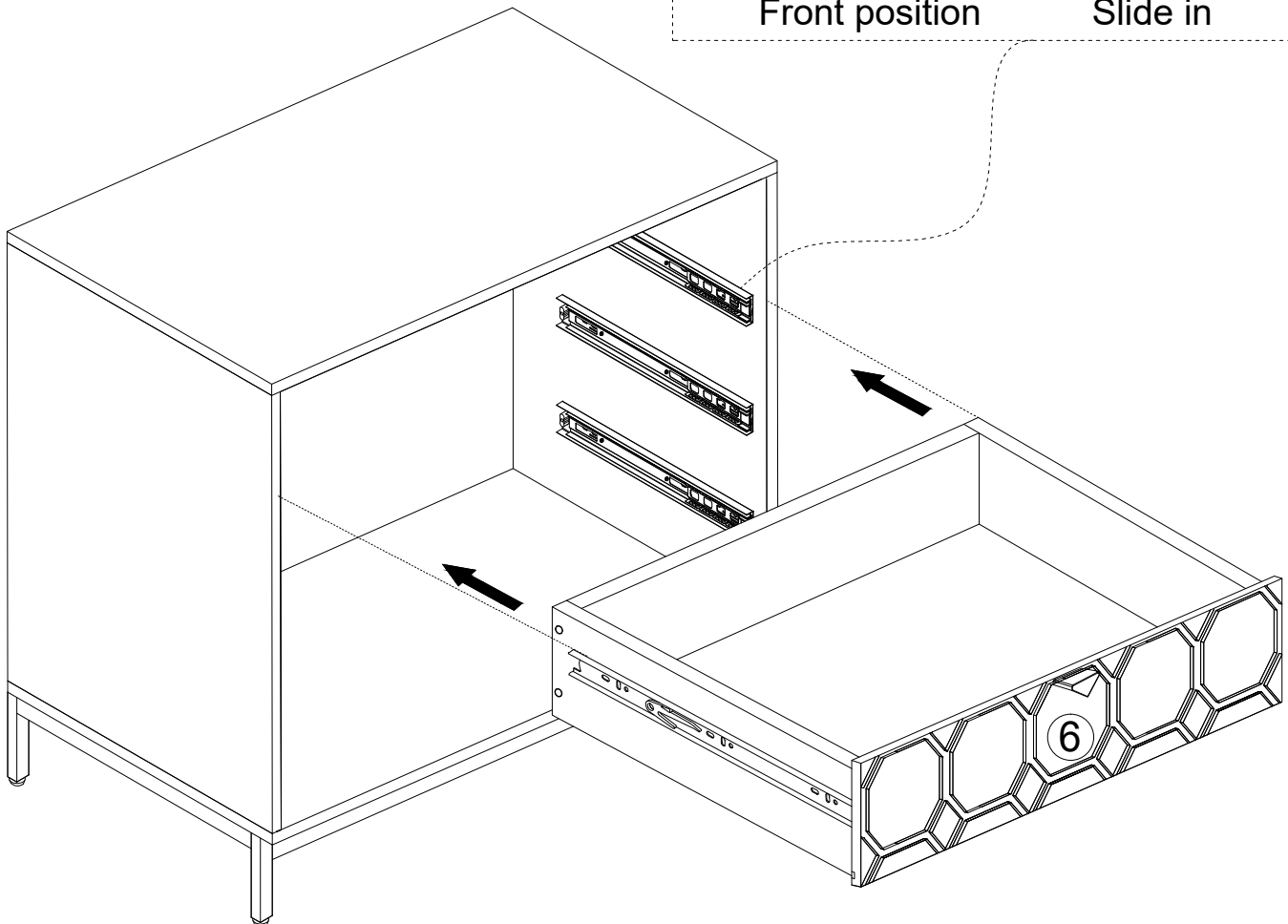
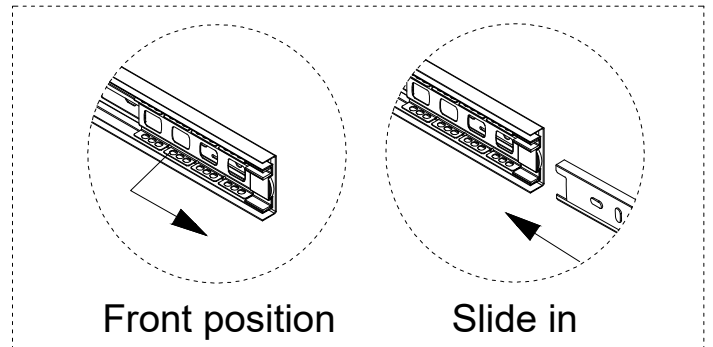

Reminder: If the front and both ends of the drawer are tilted, do not use force, You can refer to the above steps to smoothly insert the slide rail.
The 6# and 7# and 8# suction panels are not interchangeable.

ASSEMBLY INSTRUCTIONS

STEP 7

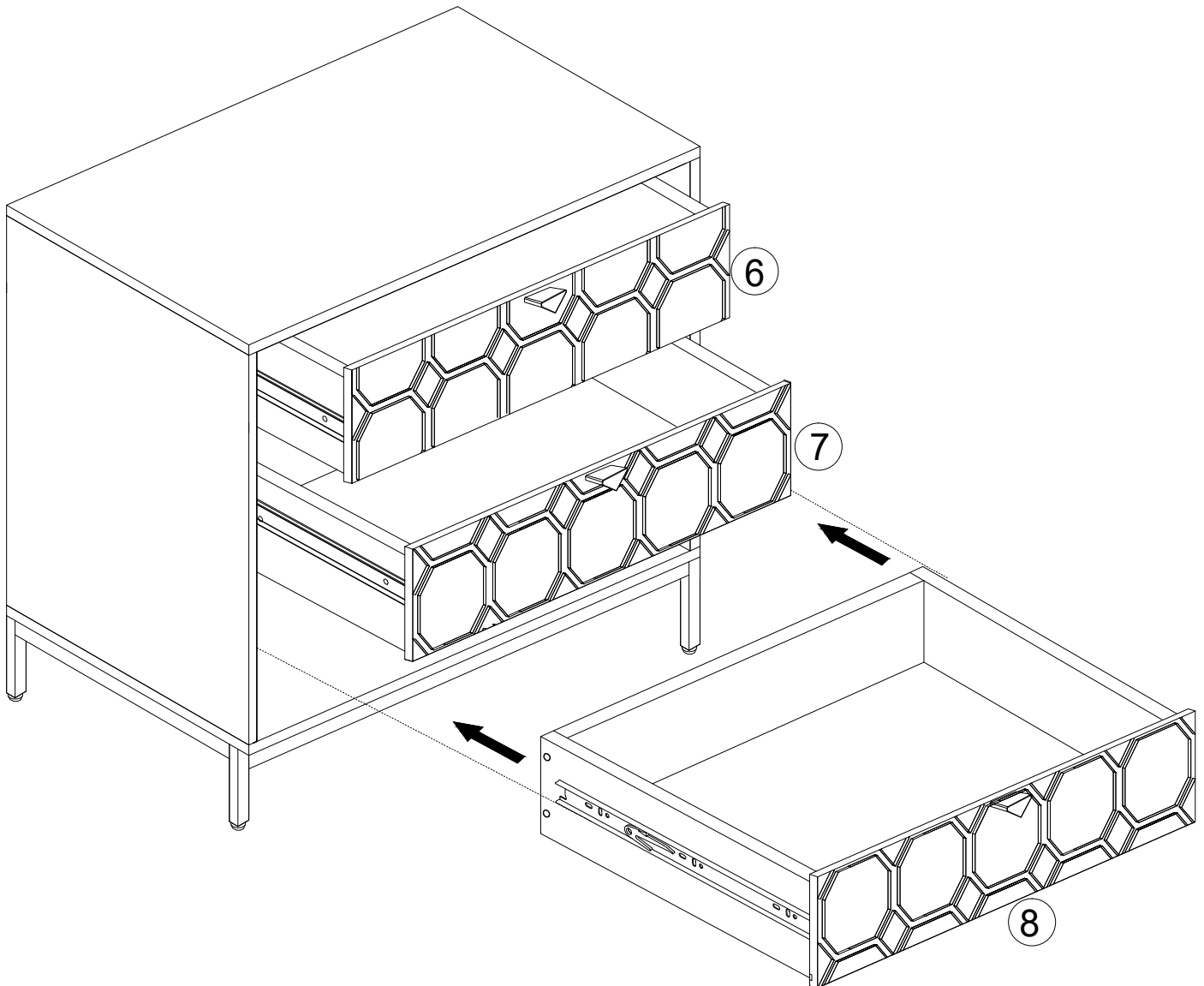

Reminder: After the installation of the drawer is completed, pull it several times to ensure smooth operation. If you need to remove the drawer, please refer to the following steps.

ASSEMBLY INSTRUCTIONS

STEP 8

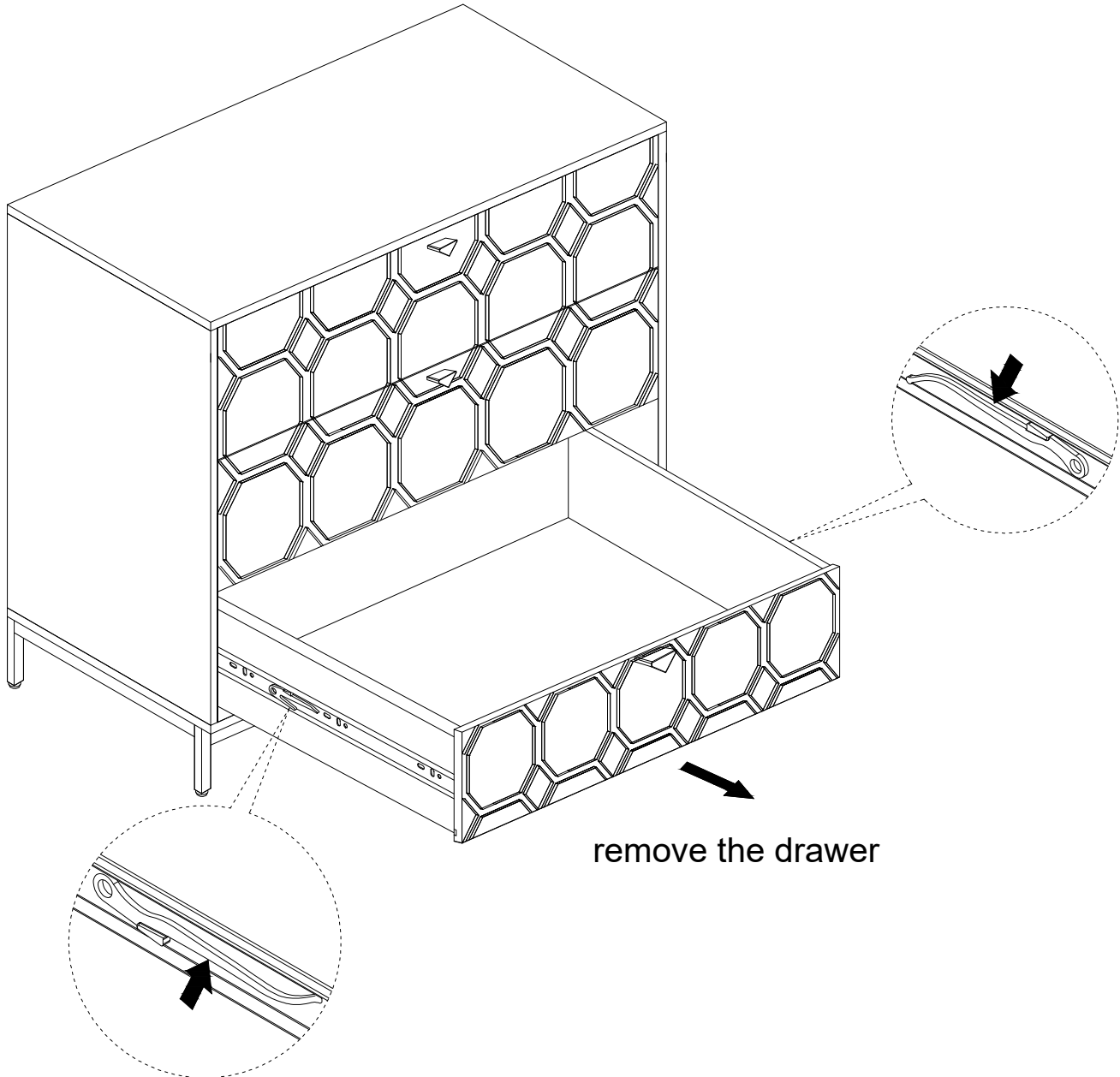



remove the drawer

To remove the drawer, lift up on the left side buckle and press down on the right side buckle, operating both left and right at the same time, and move outward to remove it.

ASSEMBLY INSTRUCTIONS

STEP 9

| | | |
|----|---|------|
| J: |  | 2PCS |
| K: |  | 2PCS |
| L: |  | 2PCS |

To install: Drill a 3/16" hole into the wall, insert wall anchor (if needed), then drive the mounting screw through the safety strap and into the wall. Tighten until the strap is snug.

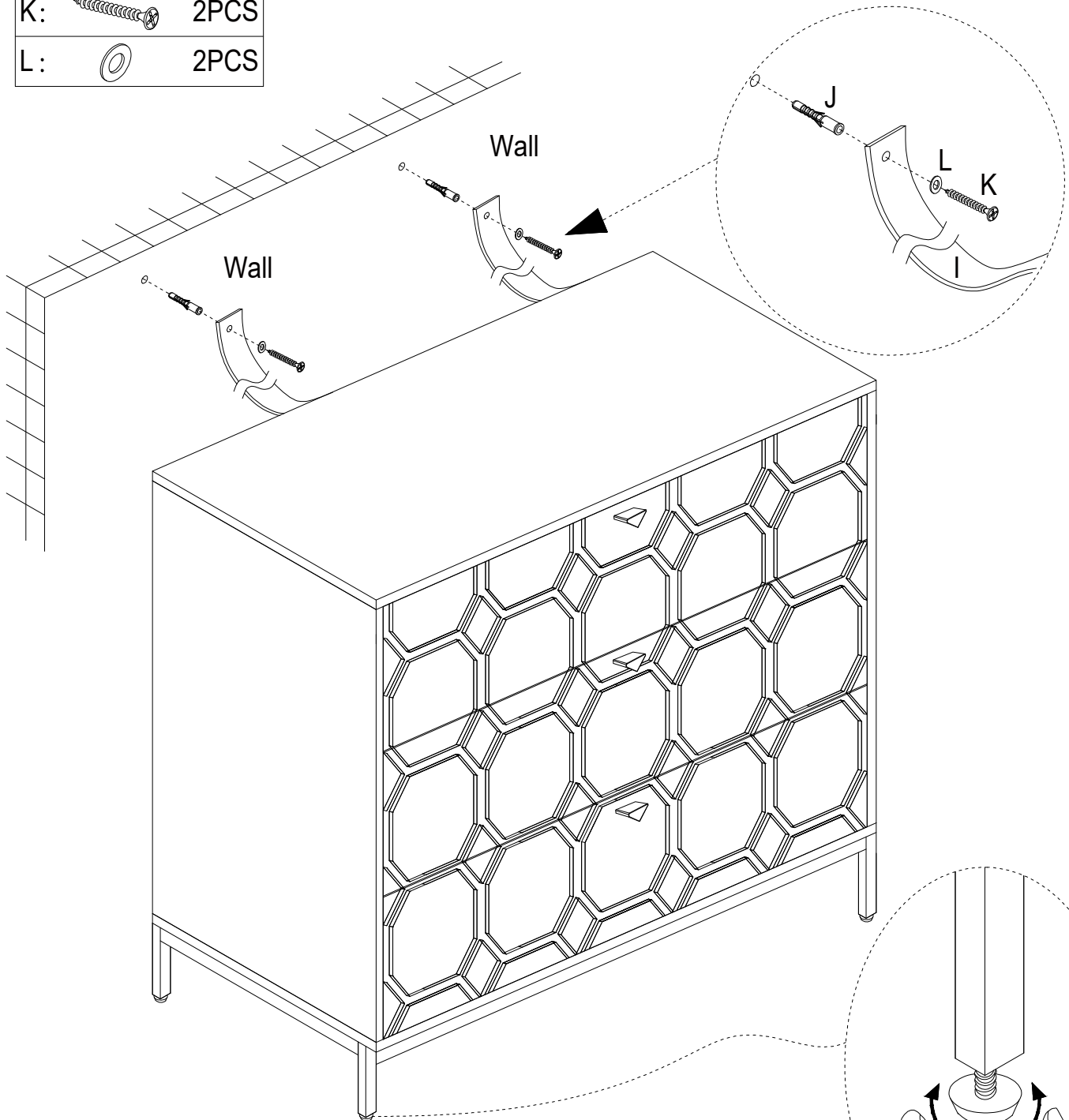

Adjust the leveling feet (located at the bottom of Part 13) by turning clockwise/counterclockwise until the cabinet stands level on the floor. Ensure all feet are in contact with the ground to prevent wobbling.

