

Side Table Coffee Color

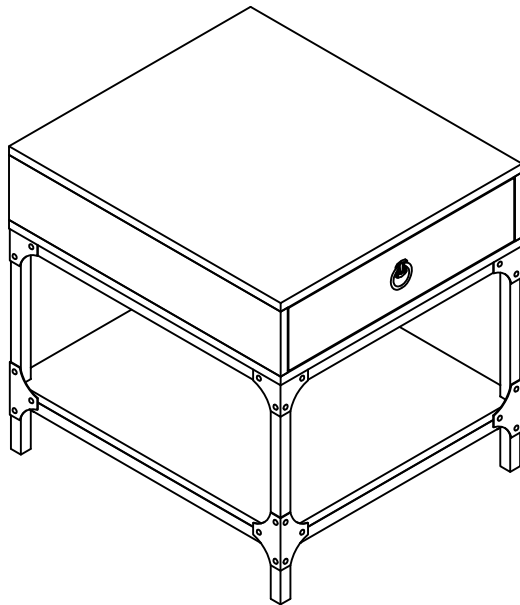

Congratulations! You have purchased a stylish piece of us. We strive to provide fine furniture products, built with quality materials and hand finished details. Please carefully follow the assembly instructions to ensure your furniture is assembled correctly to provide long lasting enjoyment.

Our Products are warranted against defects in material and workmanship for a period of 90 days beginning from the date of sale.

Should you experience any damaged, defective, or missing parts, or need help with assembly, please call us directly before contacting the retailer.

Care: Use a soft clean cloth that will not scratch the surface when dusting. Use of furniture polish is not necessary. Should you choose to use polishes, test in an inconspicuous area first. Use of solvents of any kind may damage your furniture's finish. To clean, simply use a soft clean cloth moistened with lukewarm water, then buff with a dry soft clean cloth.

PART LIST

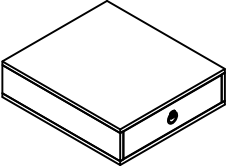
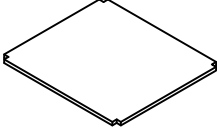
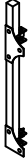
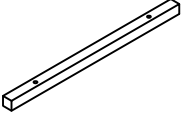
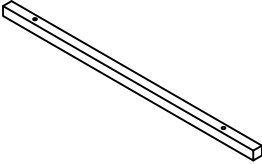
| | | |
|--|--|--|
| <p>A</p>  | <p>B</p>  | <p>C</p>  |
| <p>Top 1 PC</p> | <p>Shelf 1 PC</p> | <p>Leg 4 PCS</p> |
| <p>D</p>  | <p>E</p>  | |
| <p>Short Stretcher 4 PCS</p> | <p>Long Stretcher 4 PCS</p> | |

HARDWARE LIST

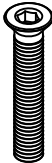
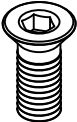
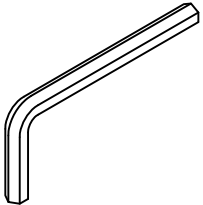
| | | |
|---|---|---|
| <p>1</p>  <p>Ø1/4*1-3/8"</p> | <p>2</p>  <p>Ø1/4*1/2"</p> | <p>3</p>  <p>4*4</p> |
| <p>Long Hex Socket Head Bolt 16 PCS</p> | <p>Short Hex Socket Head Bolt 16 PCS</p> | <p>Allen Wrench 1 PC</p> |

Step 1 : Open a carton, take out three cartons of long stretchers (part#E), legs (part#C), and short stretchers (part#D) from the back of table top frame firstly.

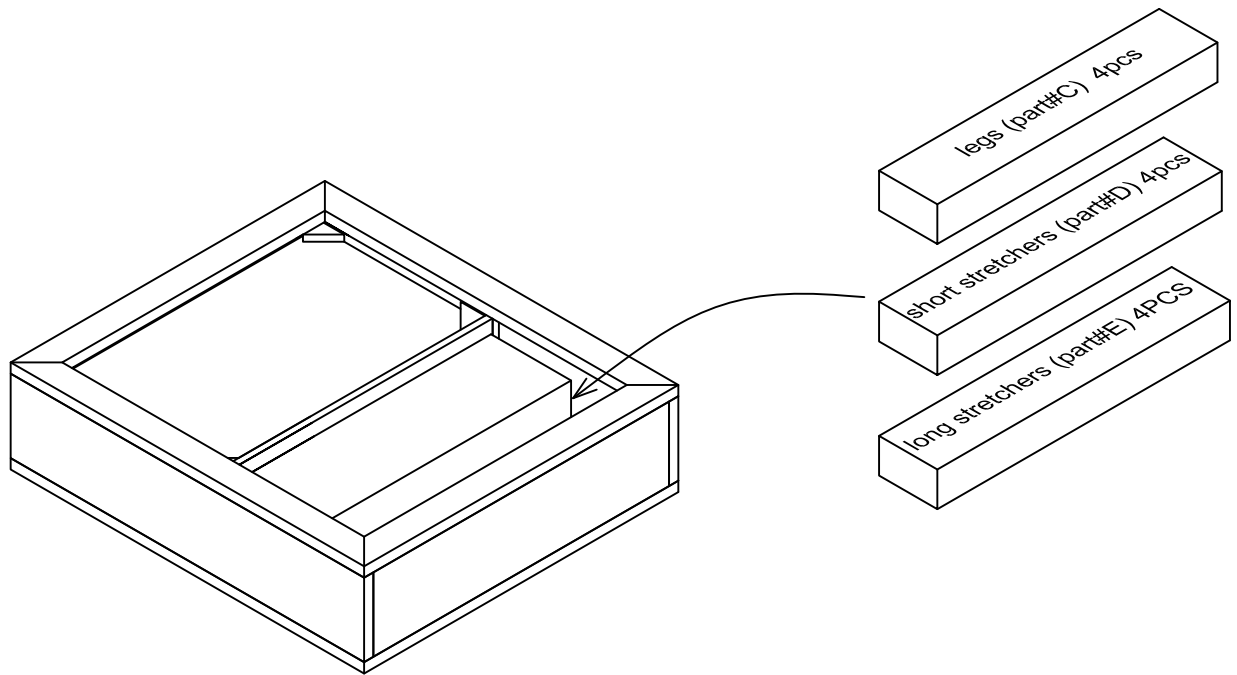

NOTE: Please do not fully tighten bolts until unit is fully assembled.

Step 2: Attach long stretchers (part #E) and short stretchers (part #D) to top (part #A) by using long hex socket head bolts (#1) and allen wrench (#3).

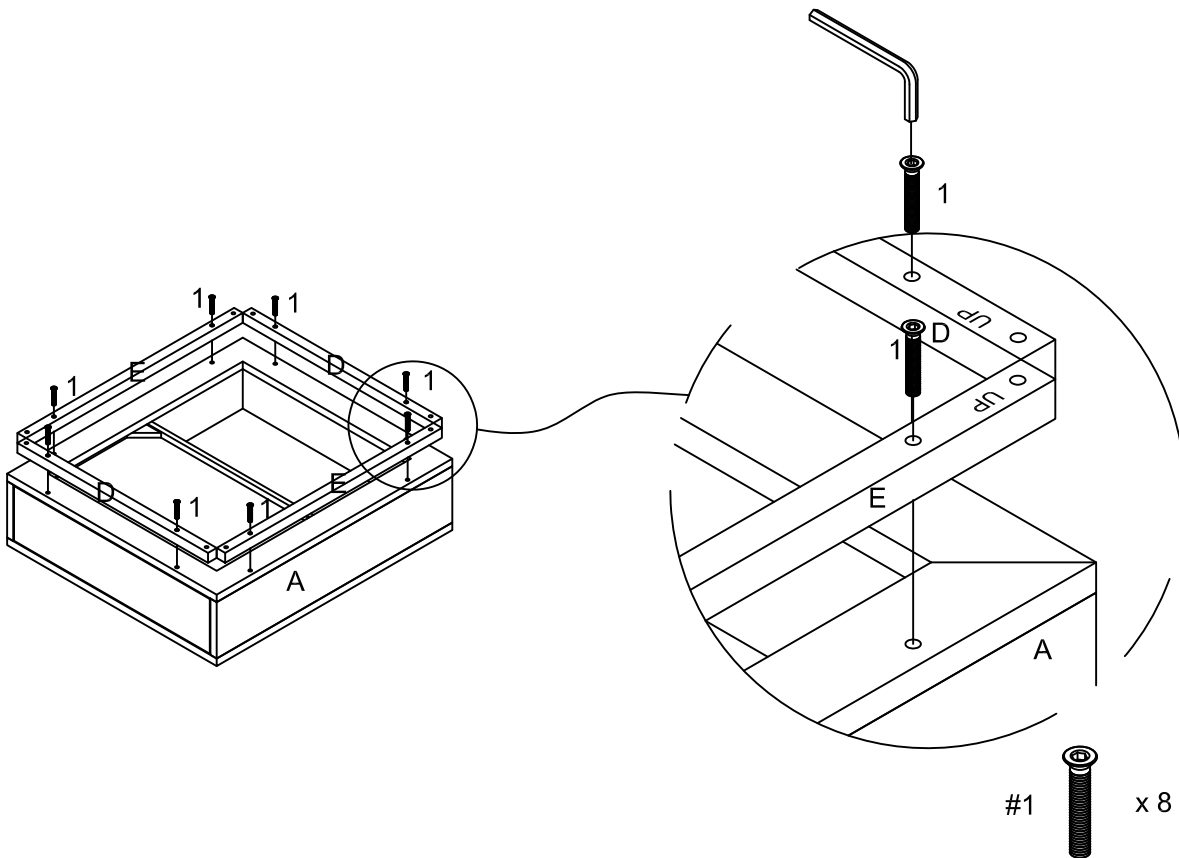

Step 3: Attach long stretchers (part #E) and short stretchers (part #D) to shelf (part #B) by using long hex socket head bolts (#1) and allen wrench (#3).

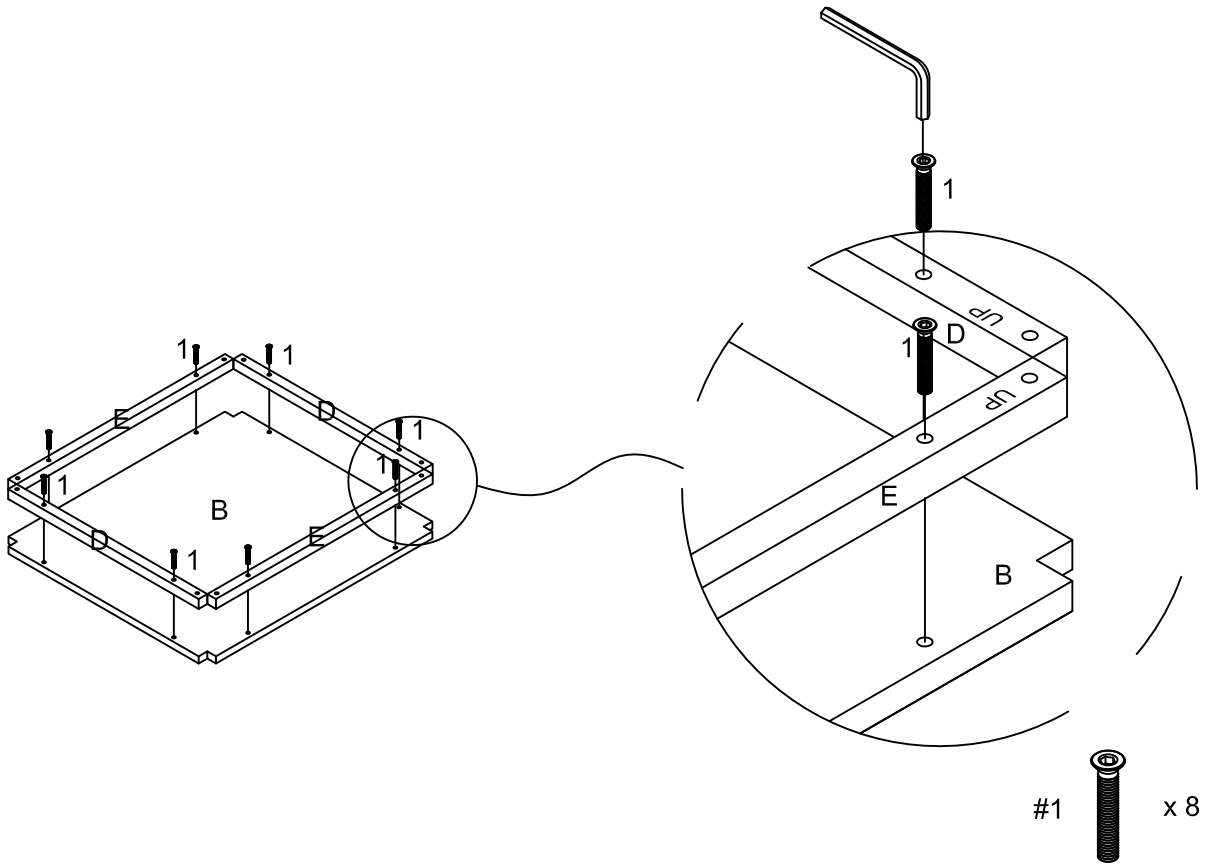

Step 4: Attach legs (part #C) to top (part #A) by using short hex socket head bolts (#2) and allen wrench (#3).

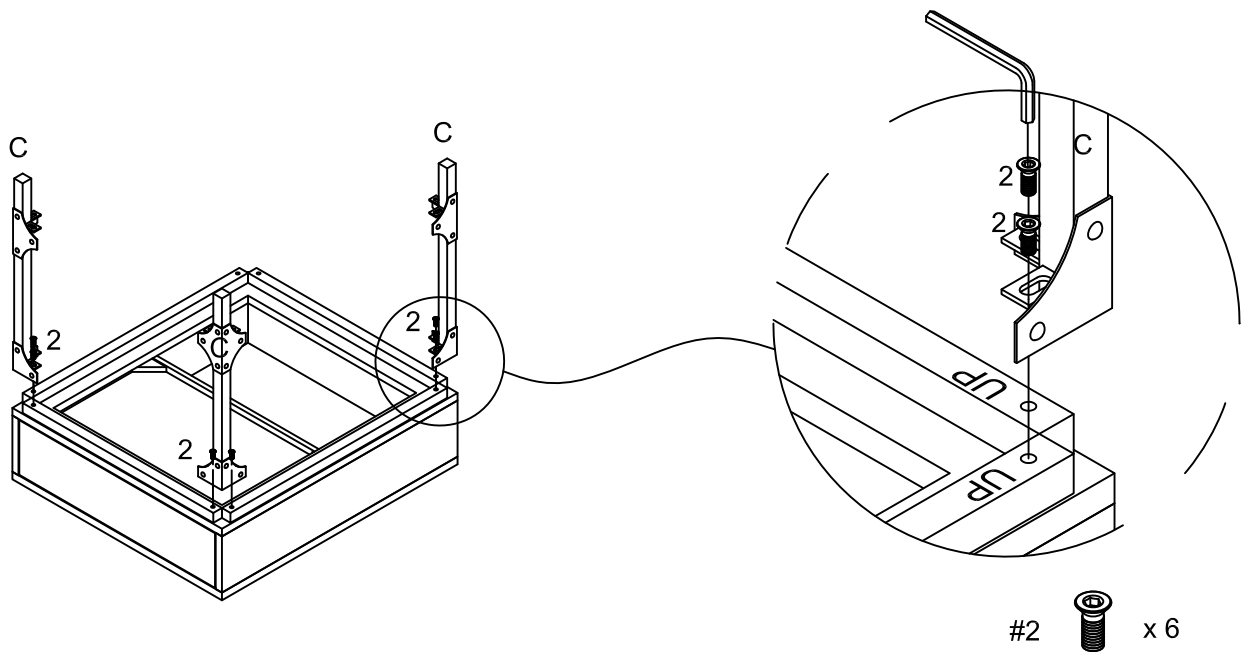

Step 5: Attach shelf (part #B), long stretchers (part #E) and short stretchers (part #D) to legs (part #C) by using short hex socket head bolts (#2) and allen wrench (#3).

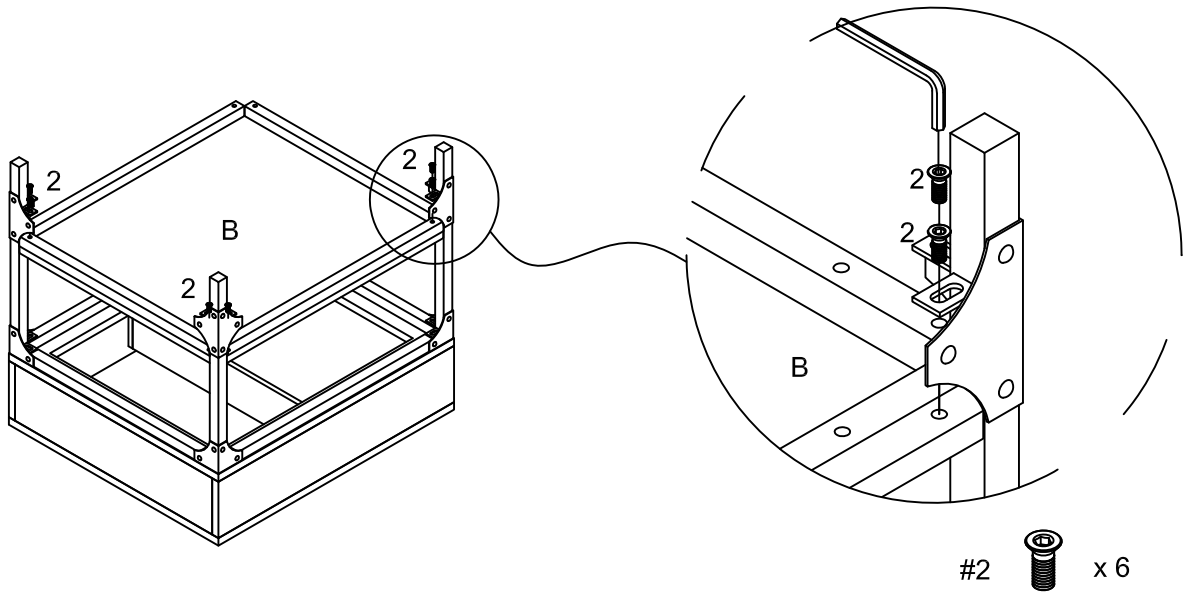

Step 6: Attach leg (part #C) to top (part #A) and shelf (part #B) by using short hex socket head bolts (#2) and allen wrench (#3).

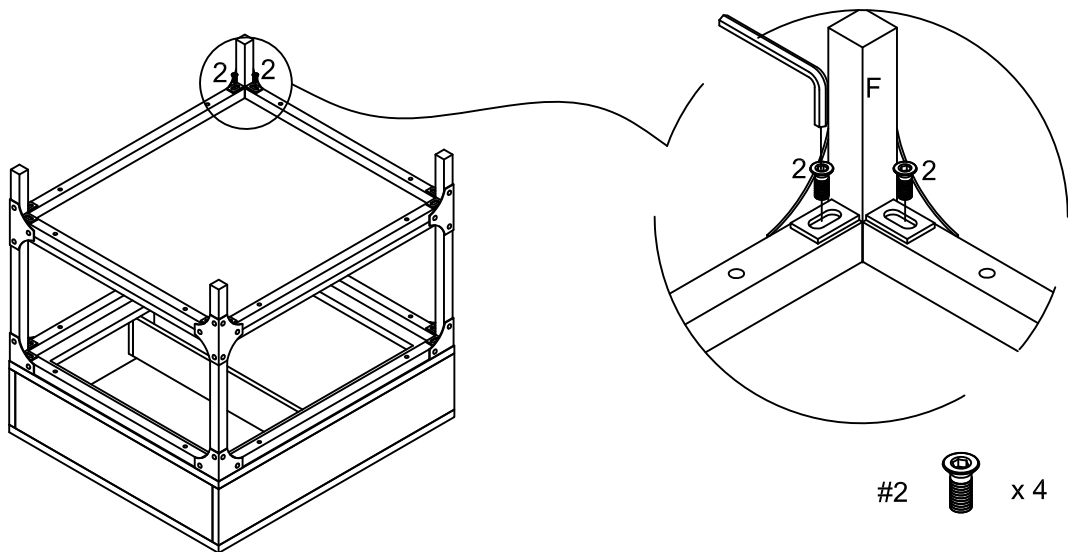

Step 7: Tighten all the bolts completed by using allen wrench (#3).

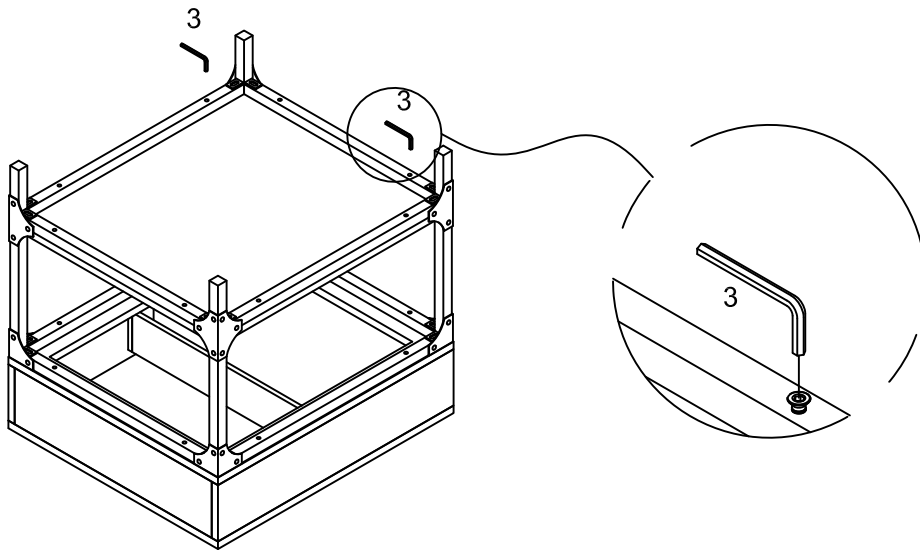

Step 8: Turn the unit upright.

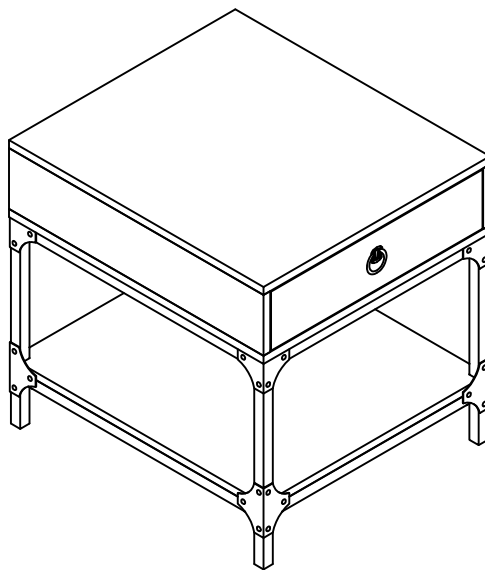

Limited Manufacturers Warranty

Our Products are warranted against defects in material and workmanship for a period of 90 days beginning from the date of sale.

Should you experience any damaged, defective, or missing parts, or need help with assembly, please call us directly before contacting the retailer.

This warranty gives the purchaser specified legal rights in addition to any rights which may vary from state to state. In accordance with the "Moss-Magnuson Warranty Act" of July 10th, 1975, this is termed a "limited warranty" which in no way compromises our high standards of Quality and Workmanship.