

Technical Data:

- Voltage: 110-120 V AC 60 Hz
- Rated power: 40W
- Noise Level: < 66 dB(A)
- Unit dimension: 15.6"H x 23.2"W x 3.9"D
- Unit weight: 13.6 lbs.

Medify Air  
1325 SW 30th Avenue  
Deerfield Beach, FL 33442  
888-258-1008  
info@medifyair.com  
www.medifyair.com

# Medify Air

Model : MA-WM35

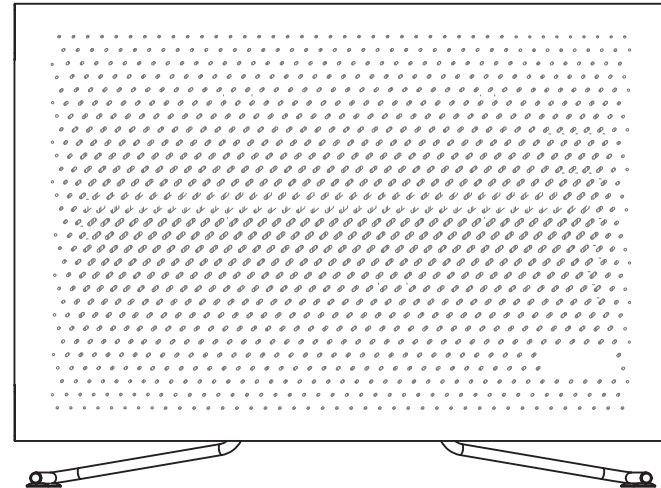

Read this manual before using.  
Operate the unit according to the instructions provided.  
Keep this for future reference.

## TABLE OF CONTENTS

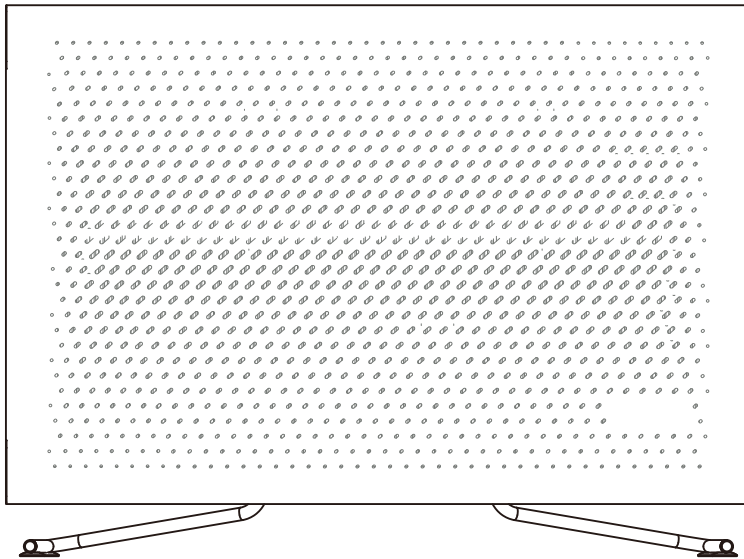

1.Safety Precautions.....	3
2.Product introduction.....	4
3.Product configuration list.....	6
4.Product use.....	7
Control panel functions.....	7
ON/OFF button .....	8
Adjustment of the fan speeds.....	8
Timer mode.....	8
Sleep mode.....	8
Child-lock function.....	8
Auto mode.....	8
Ionizer mode.....	8
Filter reset.....	8
Purification indicator.....	9
Digital display window.....	9
Description of TVOC indicator light.....	9
5.Installation guide.....	9
Desktop installation.....	9
Wall mounted installation.....	11
6.Filter purification steps.....	13
7.Maintenance and Cleaning.....	14
8.Warranty and service.....	15
Order filters.....	15
Lifetime Warranty.....	16

# User Manual

## 1. Safety Precautions

In order to avoid damage to you, others or property, follow the safety precautions.

If the power cord or unit is out of order, contact Medify Customer Service immediately.



### WARNING



Do not touch power plug with wet hands.



Turn off the power before cleaning machine.



This is a 110v unit. It is NOT made for 220v use. Plugging into a 220v outlet will burn out the motor and circuits and the unit will no longer work. Only use with a 110v outlet



Keep machine dry.



Only a soft clean cloth is to be used. Do not use solvents like Benzene, Alcohol or any flammable cleaners to clean the air purifier

Turn off power immediately in case of any of the following:

- Malfunction of any switch
- Circuit failure
- Abnormal heating of wires or plugs
- Any other malfunction



**WARNING: Keep batteries away from children.**

This product contains a lithium button/coin cell battery.

If a new or used lithium button/coin cell battery is swallowed or enters the body, it can cause severe internal burns and can lead to death in as little as 2 hours. Keep battery compartment closed at all times.

If the battery compartment does not close securely, stop using the product, remove the batteries, and keep them away from children. If you think batteries might have been swallowed or placed inside any part of the body, seek immediate medical attention. Make sure to dispose of this and all batteries properly.

# User Manual

## 2. Product introduction

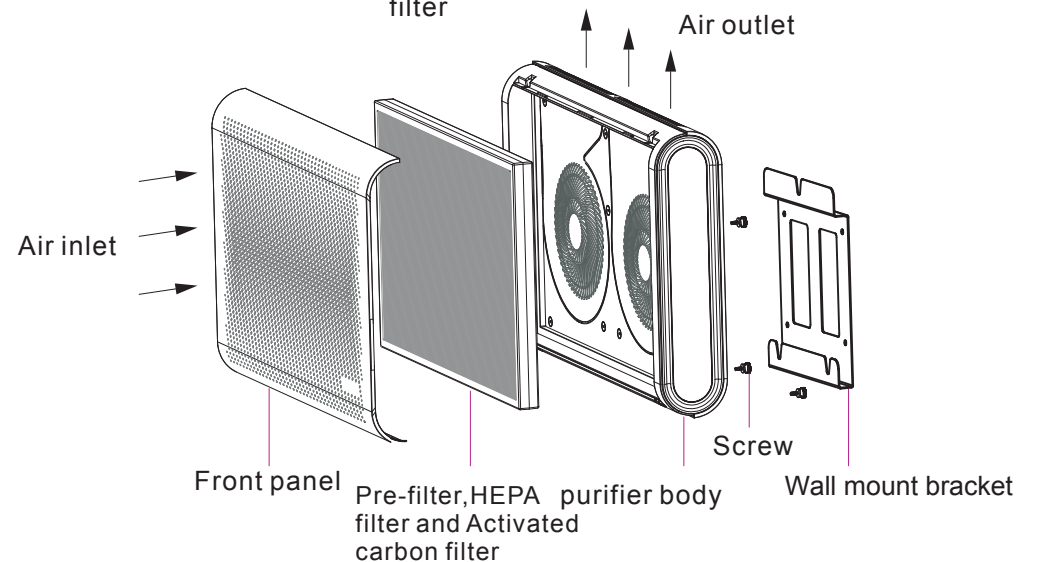
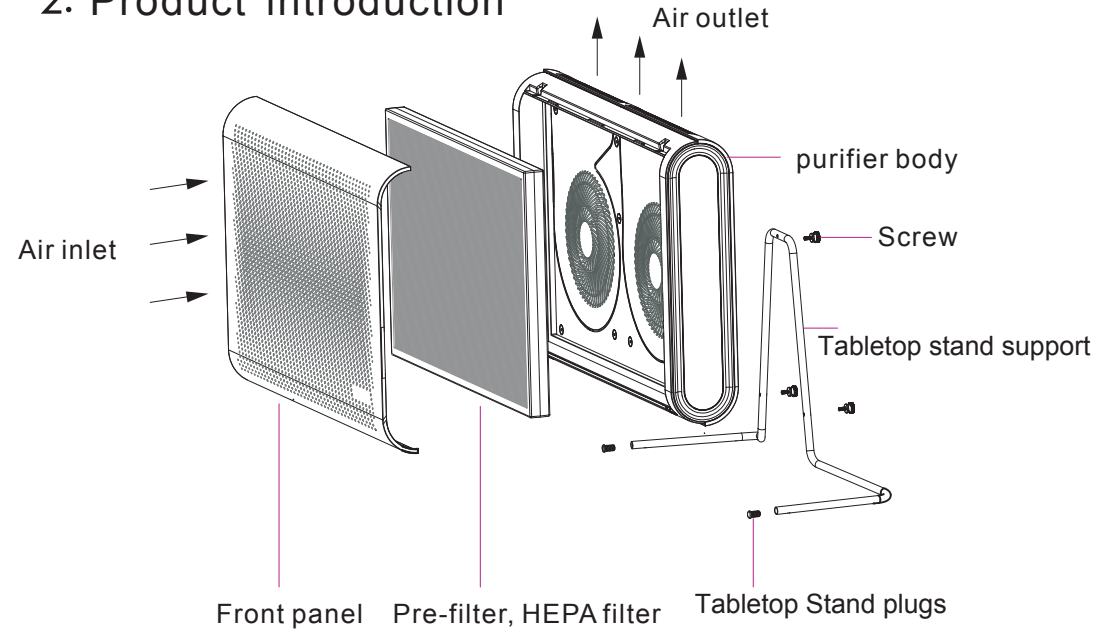

# User Manual

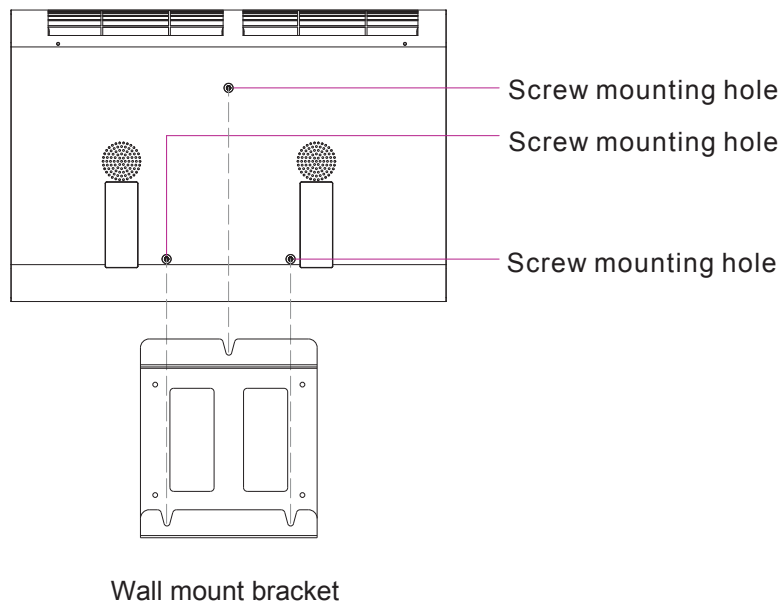
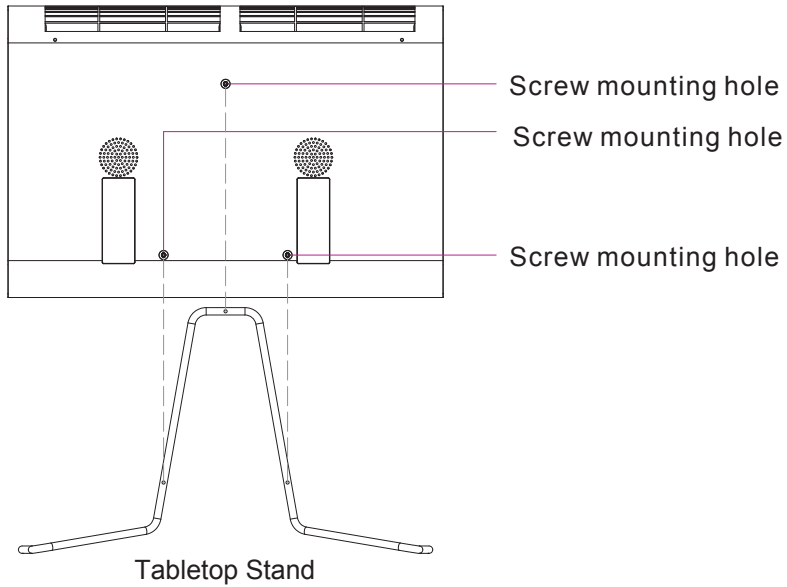

# User Manual

## 3. Product configuration list

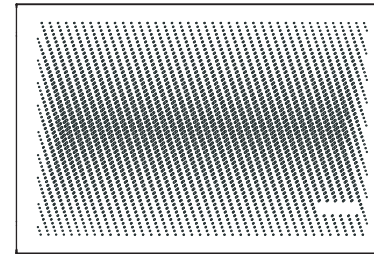

Purifier body 1pc

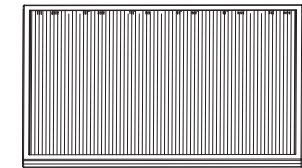

Filter 1pc

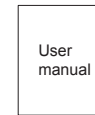

User manual



Warranty card



Remote control



Screw

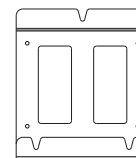

Wall mount bracket 1pc



Expansion plug 4pcs



Self tapping screw 4pcs

### Optional configuration

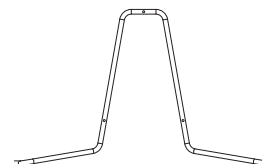

Tabletop Stand 1pc



Tabletop stand plug 2pcs

# User Manual

## 4. Product use

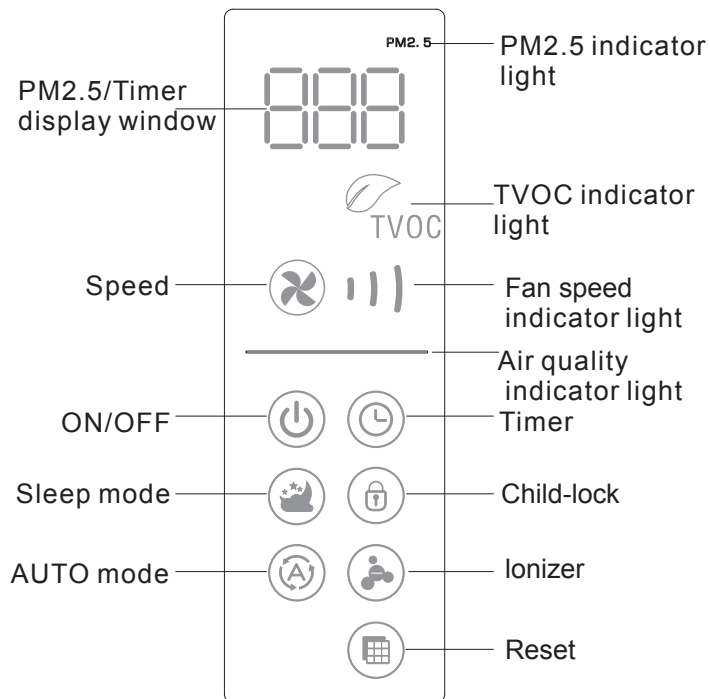
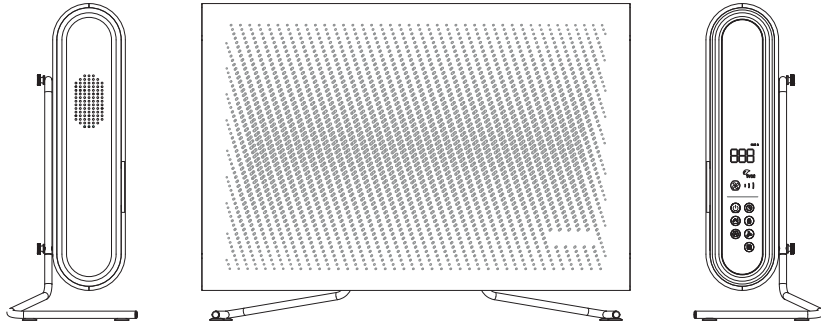

# User Manual

### 1. ON/OFF

Press ON/OFF button and unit will turn on. Machine starts to work in low speed. Press the button again, machine stops and is in standby mode.

### 2. Manual adjustment of fan

Press speed button to choose your speed. Options are: 1,2,3.

### 3. Timer mode

Press timer button and choose hour options: 1,2,3...24 or no timer.

### 4. Sleep mode

Press sleep button to enter into sleep mode, all other indicators lights will turn off. Fan speed and noise level will change to the lowest setting. After 10 seconds, the sleep indicator light goes out as well. Press any key to exit sleep mode.

### 5. Child-lock function

In this mode, none of the function keys can be used or changed. (Except the child lock function). To turn on the child lock, hold the button down for 3 to 5 seconds. To turn off the child lock function, hold the button down for 30 to 45 seconds.

### 6. Auto mode

Press AUTO button, unit will sound and indicator of Auto mode will be on. The air purifier will choose fan speed according to the air quality:  
 Excellent--Low fan speed  
 Good-----Middle fan speed  
 Poor-----High fan speed

Air quality	Display window	Indicator light color
Excellent	0-75	Blue
Good	76-150	Green
Poor	Above 150	Red

### 7. Ionizer Mode

Ionizer is an On/Off function. You can choose to leave it on or off at your discretion. When Ionizer is on, the indicator light will be lit.

### 8. Filter reset

The indicator icon will become lit when filter needs to be changed. Lift the front cover and remove old filter from the unit. Remove plastic packaging from the new filter before installing into the air purifier. Place new filter into the air purifier with tab at top of filter should be facing you. Replace front cover back. After new filter is installed and unit is turned back on. Hold down the filter reset button for 3-5 seconds and the indicator light will go off and timer is reset for 3000 hours.

**Attention**

Make sure to unplug before changing filter. Remove all plastic packaging from filter before installing. Do Not run the air purifier when no filter is installed.

# User Manual

## 9. Purification indicator

After power on, the purification indicator light remains on for a long time

## 10. Digital display window

Figure represents indoor PM2.5 or timer setting time (displays for 5 seconds)

## 11. Description of TVOC indicator light

- Red: air quality is poor
- Green: air quality is good
- Blue: air quality is excellent

## 5. Installation guide

### Desktop

#### 1. Install tabletop stand plug

Put 2 plugs into the tabletop stand hole as shown in the figure

#### 2. Install tabletop stand

Install the 3 bracket screw from the bracket holes to the purifier body as shown in the figure

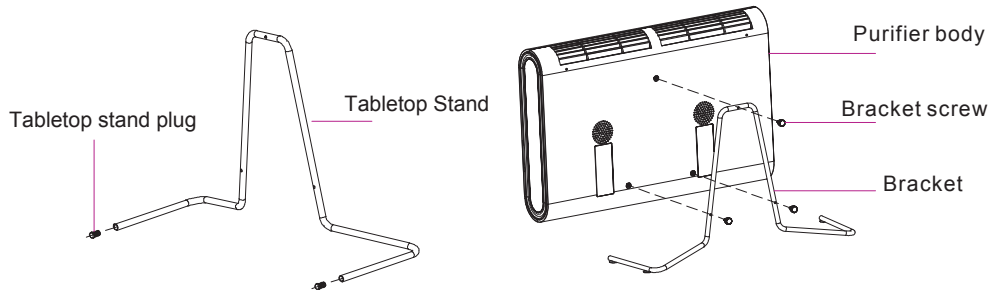

# User Manual

## 3. Take off the front panel

Fasten the left and right sides of the front panel, lift it slightly and take off the front panel

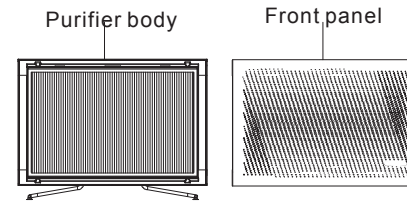

## 4. Take out filter, remove plastic packaging and dispose of it properly

Take the handle on the left and right sides of the filter, gently take it out from the purifier body, remove the plastic packaging and dispose of it properly, and then put the filter back into the purifier.

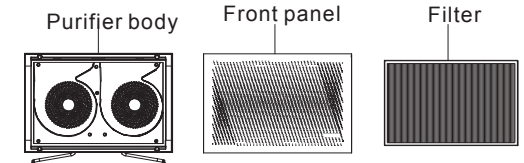

## 5. Cover the front panel

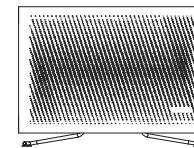

# User Manual

## Wall mounted

### 1. Marking installation position

First, select the appropriate installation position (66.9 inches away from the ground) remove wall bracket from the package, hold wall bracket against the wall, mark the position of the screw holes with a pencil on your wall and remove wall bracket.

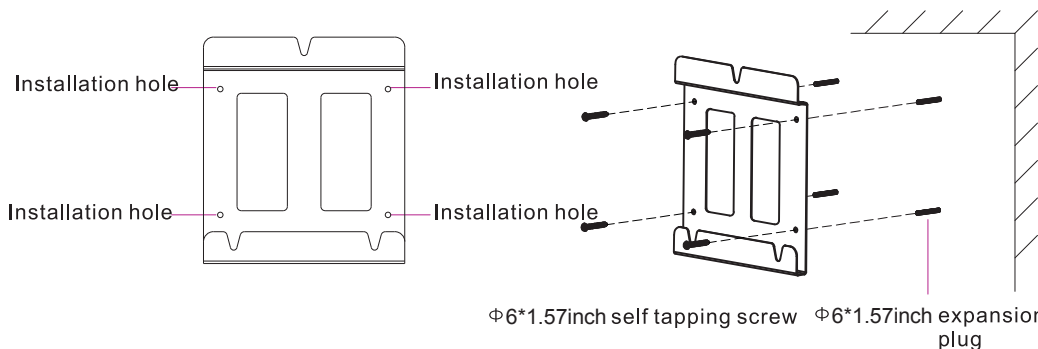

### 2. Installation of wall bracket

Drill 4 holes on the 4 pencil marks you just made on wall. Insert the 4 rubber plugs into the wall. Then hold wall bracket up and align with the holes. Screw in the 4 self-tapping screws.

### 3. Purifier body install socket

Put 3pcs of M4\*0.47inch screws into the purifier body

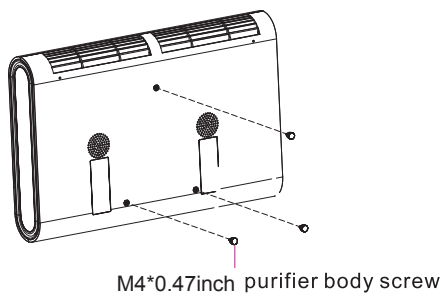

### 4. Hang the purifier body

Align the 3pcs screws on the back of the purifier with the gap on the wall bracket to make it firm.

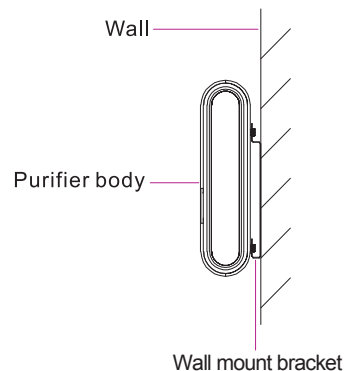

# User Manual

### 5. Take off the front panel

Fasten the left and right sides of the front panel, lift it slightly and take off the front panel

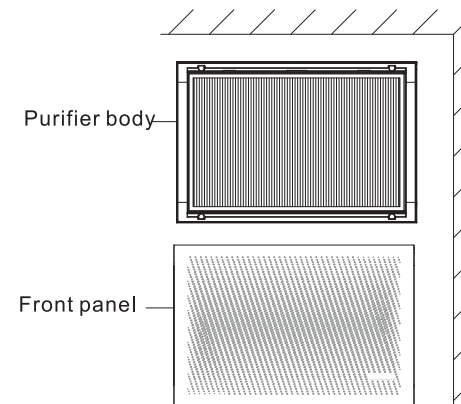

### 6. Take out filter, remove plastic packaging and dispose of it properly

Take the handle on the left and right sides of the filter, gently take it out from the purifier body, remove the plastic packaging and dispose of it properly, and then put the filter back into the purifier.

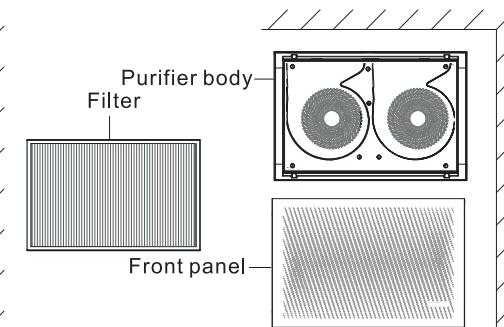

### 7. Cover back the front panel, insert the power plug into the socket, and the purifier can be used

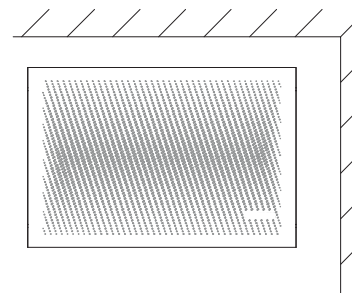

# User Manual

## 6. Filter Purification: Four Steps

First step: Pre filter

Second step: True HEPA H13 Filter

Third step: Activated carbon filter

Fourth step: Ionizer

### 1. Pre-Filter

Removes large particles such as: Dust, Dander, Hair and others

### 2. True HEPA H13 Filter

HEPA H13 is a higher grade of TRUE HEPA that can remove 99.9% of particles down to 0.1 microns as well as PM2.5 particles such as smoke, pollen, dust mites and others.

### 3. Activated Carbon Filter

Absorbs odors, harmful VOCs, and other toxic substances such as formaldehyde.

### 4. Ionizer

Produces negative ions to neutralize positively charged particles such as dust, bacteria, mold spores, pollen, animal dander and other airborne positive particles.

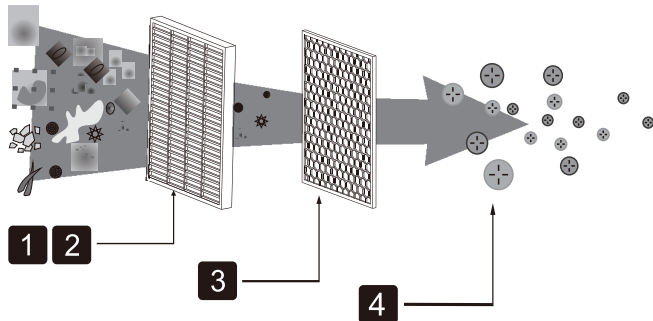

# User Manual

## 7. Maintenance and Cleaning

Unplug air purifier before cleaning the unit. Do not use excess water to clean the unit. Use a soft cloth or a soft moist cloth to wipe down unit. Do not use cleaners or chemicals on the air purifier at any time.

### Cleaning Your Air Purifier

From time to time if you see excess dust accumulate on the unit, wipe with a clean dry cloth. Also make sure air intake and vents are free from excess dust. Do not vacuum or try and wash filter as it will clog filter.

## 8. Warranty and service

If you have any additional questions, please contact customer service.

All names and trademarks are property of Medify Air. Our company reserves the right to change the product at any time, without prior notice, and the company has no obligation to adjust products supplied earlier.

Please refer to detailed warranty terms on the following page.

To register for the lifetime warranty, please fill out the attach form and mail to:

Medify Air  
1325 SW 30th Avenue  
Deerfield Beach, FL 33442  
888-258-1008

Or complete lifetime warranty registration available on our website (preferred method)  
[www.medifyair.com](http://www.medifyair.com)

### Order Filters

You can order genuine Medify replacement filters at:  
[www.medifyair.com](http://www.medifyair.com)

### Lifetime warranty

Medify guarantees your Medify Air Purifier to be free of defects in material or workmanship for a lifetime period, provided you have completed and returned your warranty registration to Medify Air within the first 30 days of purchase, and that the filters are replaced with original and genuine Medify Air replacement filters at least once every six(6)months of after 3,000 hours of use. The filter replacement indicator will let you know when it is time to change. days, Medify Air will replace the defective unit at no charge to you and reimburse you for any shipping charges. After 30 days, Medify Air's obligation and liability under this Lifetime Warranty is dependent on your use of our genuine filters, purchased on our website or from our authorized resellers, which can be found on our website.

Our Lifetime Warranty remains in effect as long as:

1. You submit your warranty registration to Medify Air within 30 days of purchase.
2. You change filters with genuine and original Medify Air replacement filters at least once every six (6) months or after 3,000 hours of use (whichever comes first).
3. You use a proper power supply based on voltage: 110-120 V (North America & Japan).
4. There is no evidence of tampering, mishandling, neglect, accidental damage, modification, and/or repair done to the Medify Air Purifier by anyone other than authorized Medify Air service personnel.
5. Your air purifier is operated in accordance with the provided instructions.

This Lifetime Warranty is provided by:

Medify Air, 1325 SW 30th Avenue, Deerfield Beach, FL 33442.