

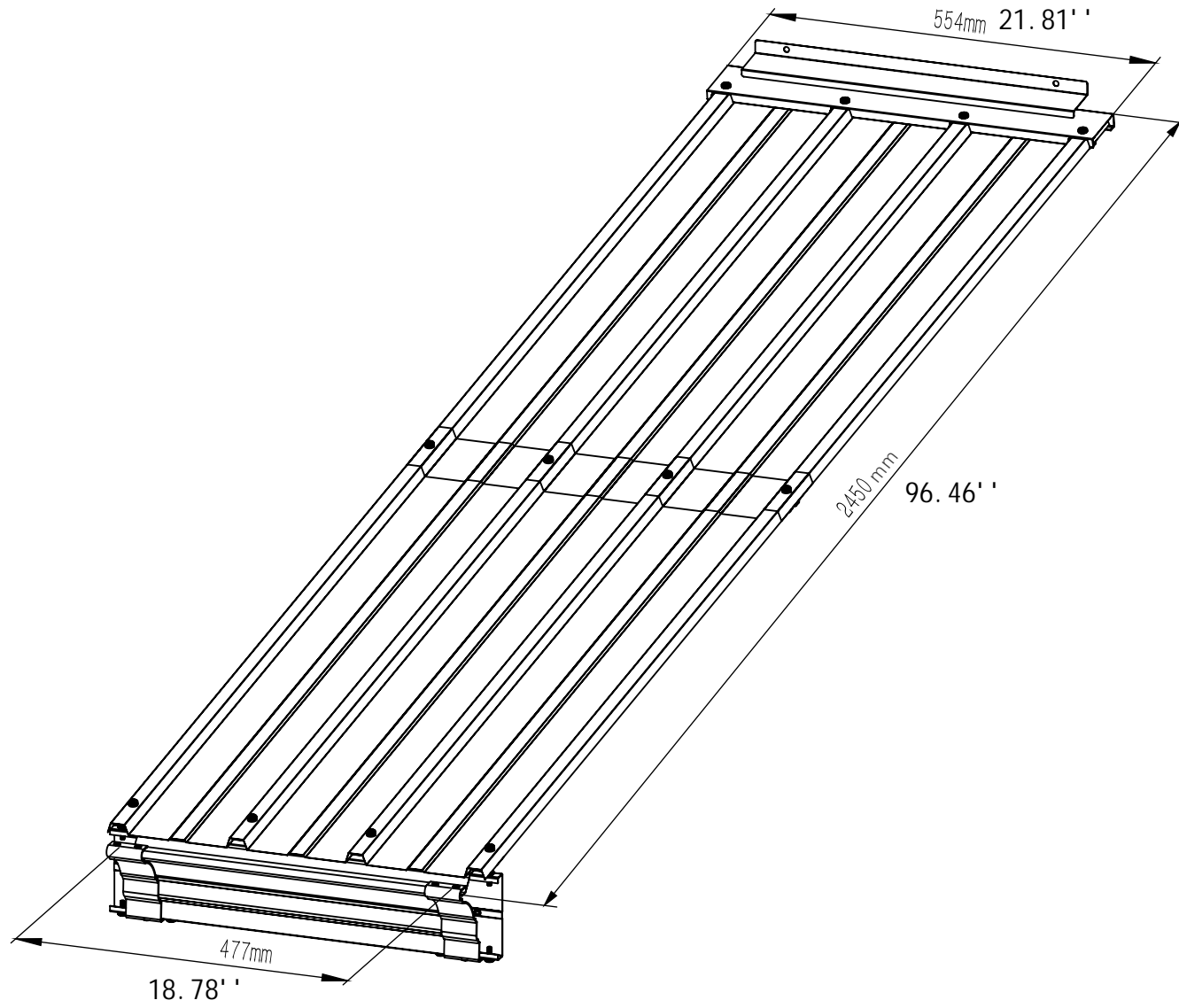

SKU: LGCF1703

ROOF CONNECTOR KIT FOR WALL-MOUNTED GAZEBO

Assembly Manual

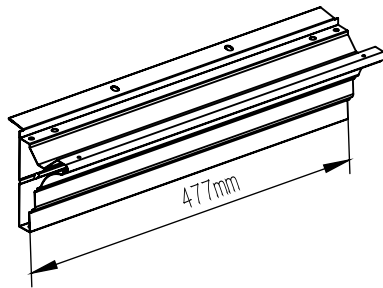
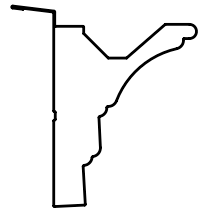
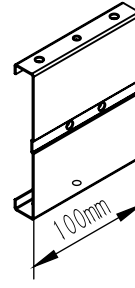
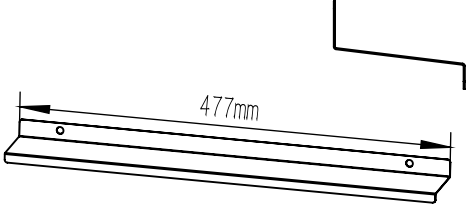
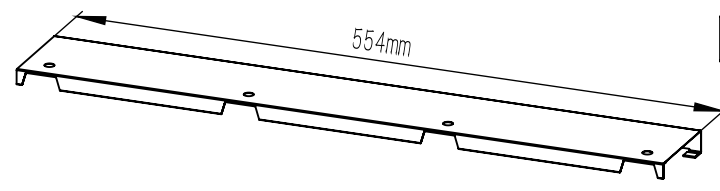
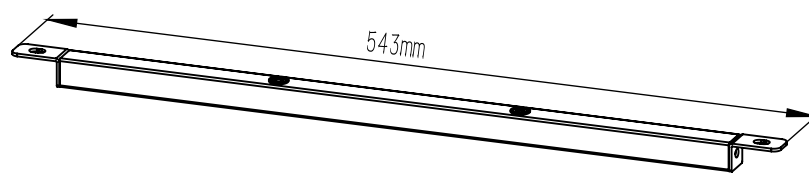
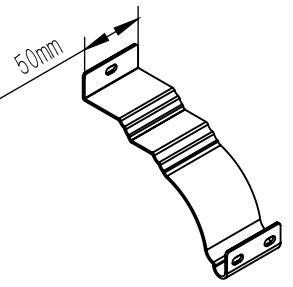
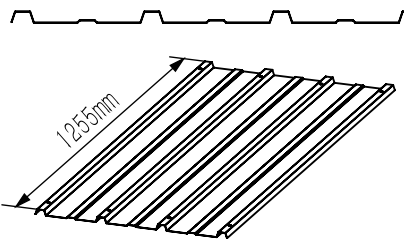
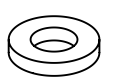
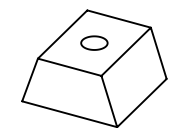
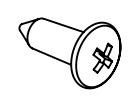
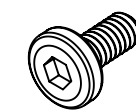
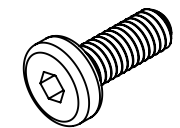
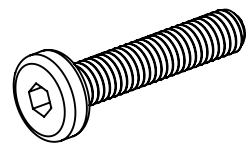
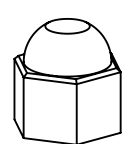
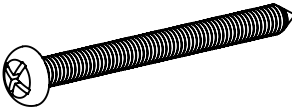
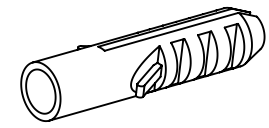
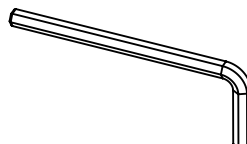

 <p>X1 1X</p>		 <p>X2 2X</p>	 <p>Y1 1X</p>	
 <p>Y2 1X</p>	 <p>Z1 2X</p>			
 <p>D4 2X</p>	 <p>M1 2X</p>	 <p>L1 12X D12/d6. 2*H2</p>	 <p>L2 12X</p>	
 <p>1# 4X ST4. 8*13</p>	 <p>2# 4X M5*12</p>	 <p>3# 10X M6*16</p>	 <p>4# 12X M6*30</p>	 <p>5# 4X M6</p>
 <p>6# 2X ST6*70</p>	 <p>7# 2X</p>	 <p>8# 1X S4</p>	 <p>9# 1X S13</p>	

Remove the side roof cover (#J3) on the left/right side of the gazebo that needs to be connected. Please follow the instruction below.

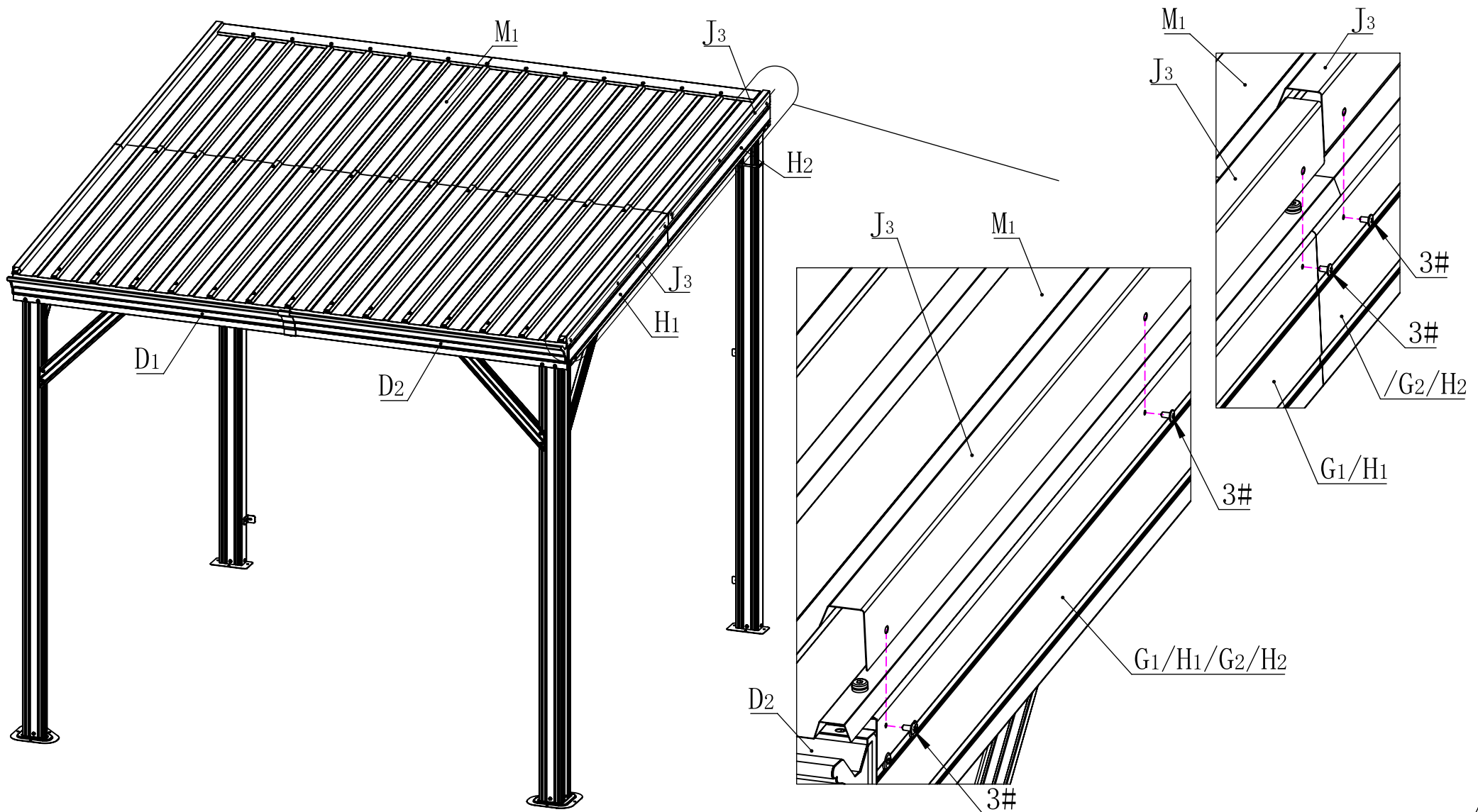

Remove the end cap from one side of the front beam of the gazebo that needs to be connected.

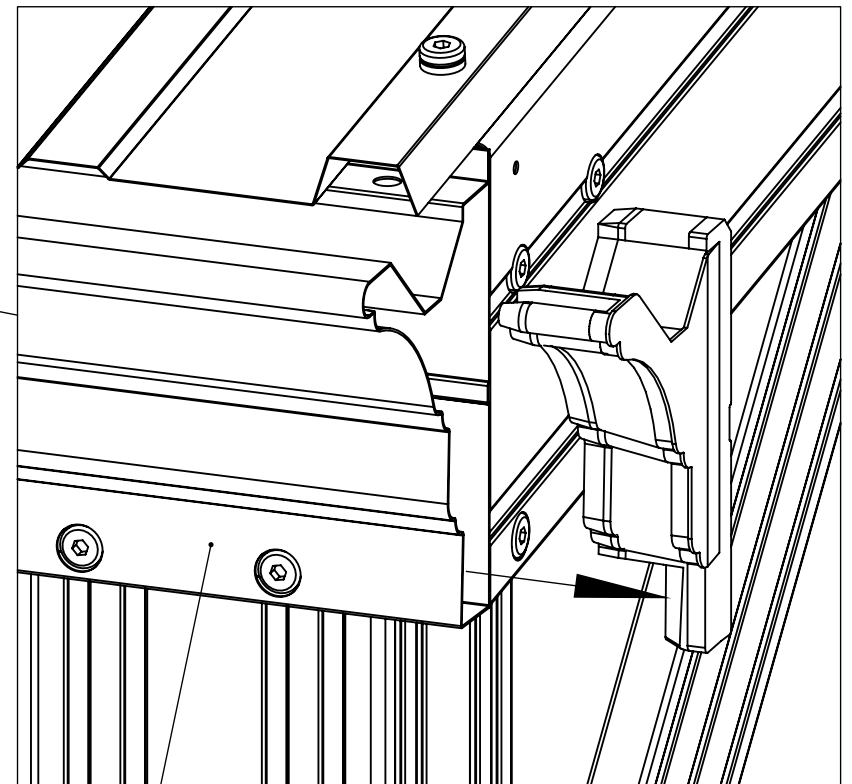
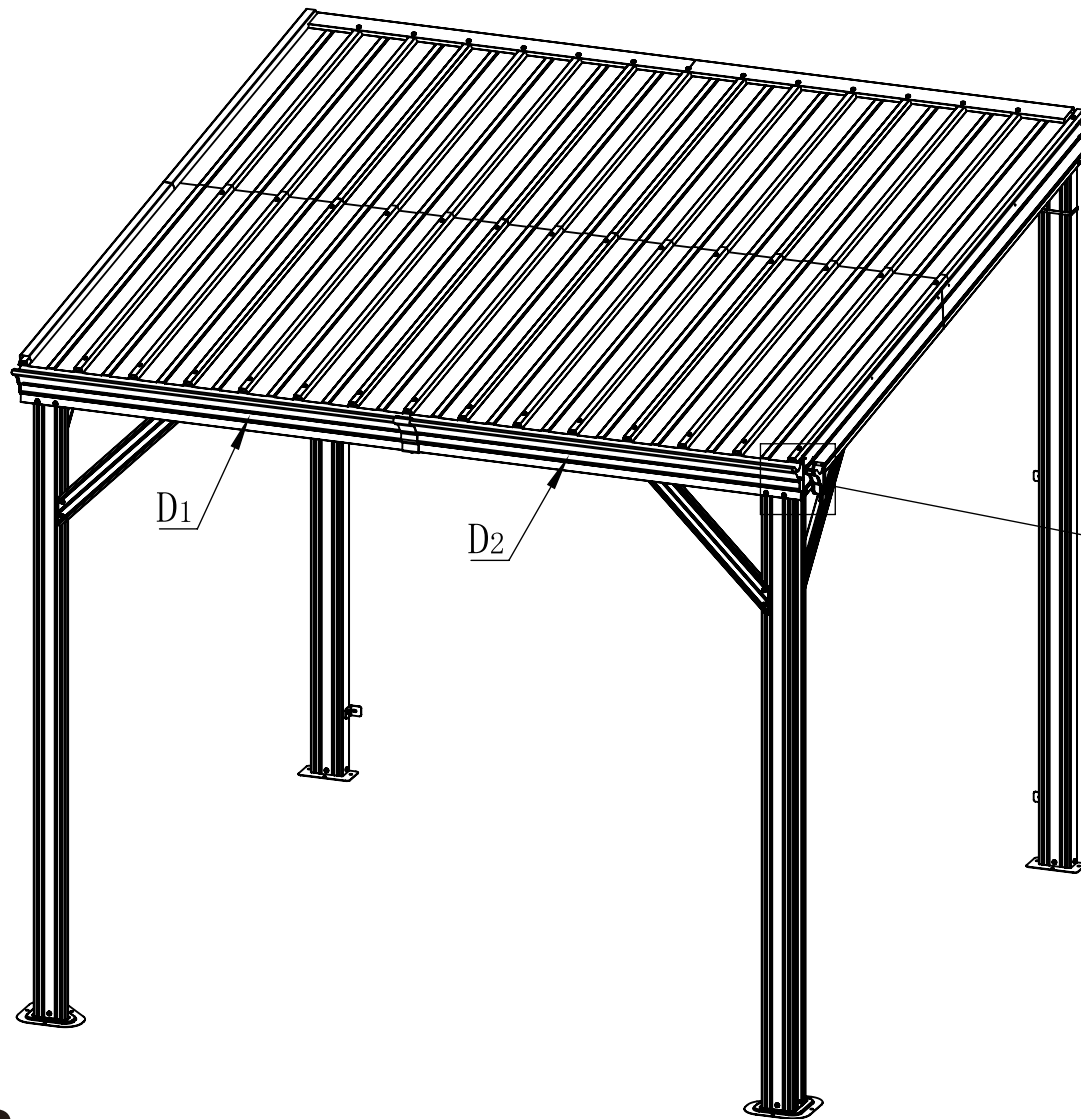

D1/D2

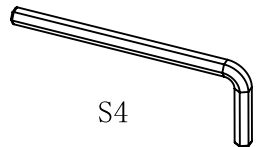

S4

8#

1X



S13

9#

1X

Remove the screws (6#/9#/#L1/#L2) on the side roof panels.

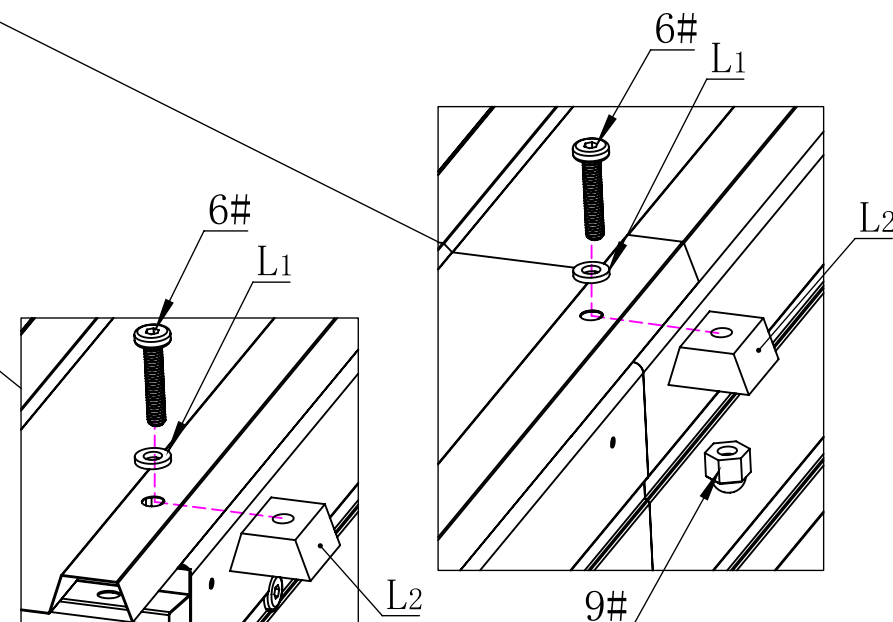
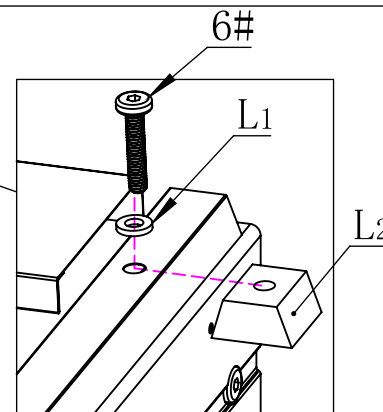

3

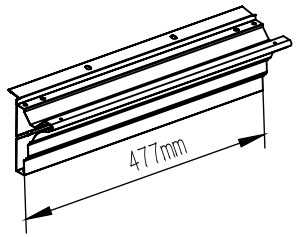

X1 1X

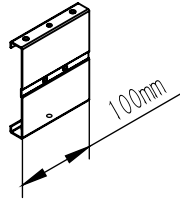

X2 2X



2# 2X

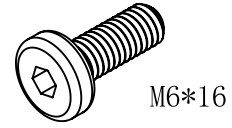

3# 6X

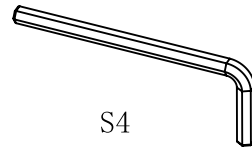

S4 8# 1X

Insert 2 connection parts #X2 into beam #X1 and secure with 6 bolts 3# and 2 bolts 2#.

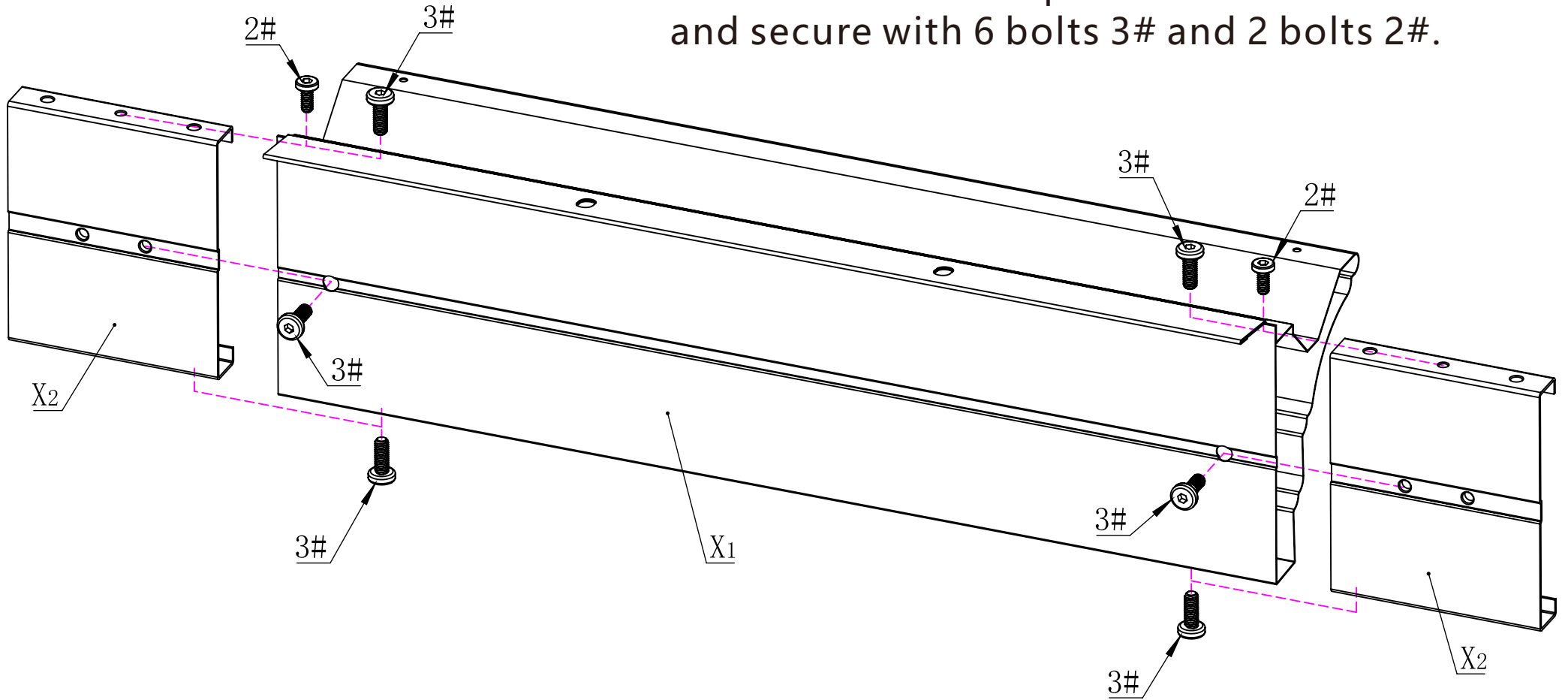

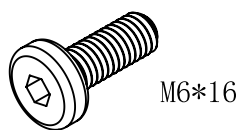

M6*16

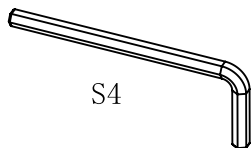

S4

Note: Please ensure the roof panels on the right gazebo are NOT installed before assembly as you may need to stand under it.
Connect #D2 and #X1 with 2 bolts 3#.

3#

4X

8#

1X

Repeat above procedure on #D1 and #X1.

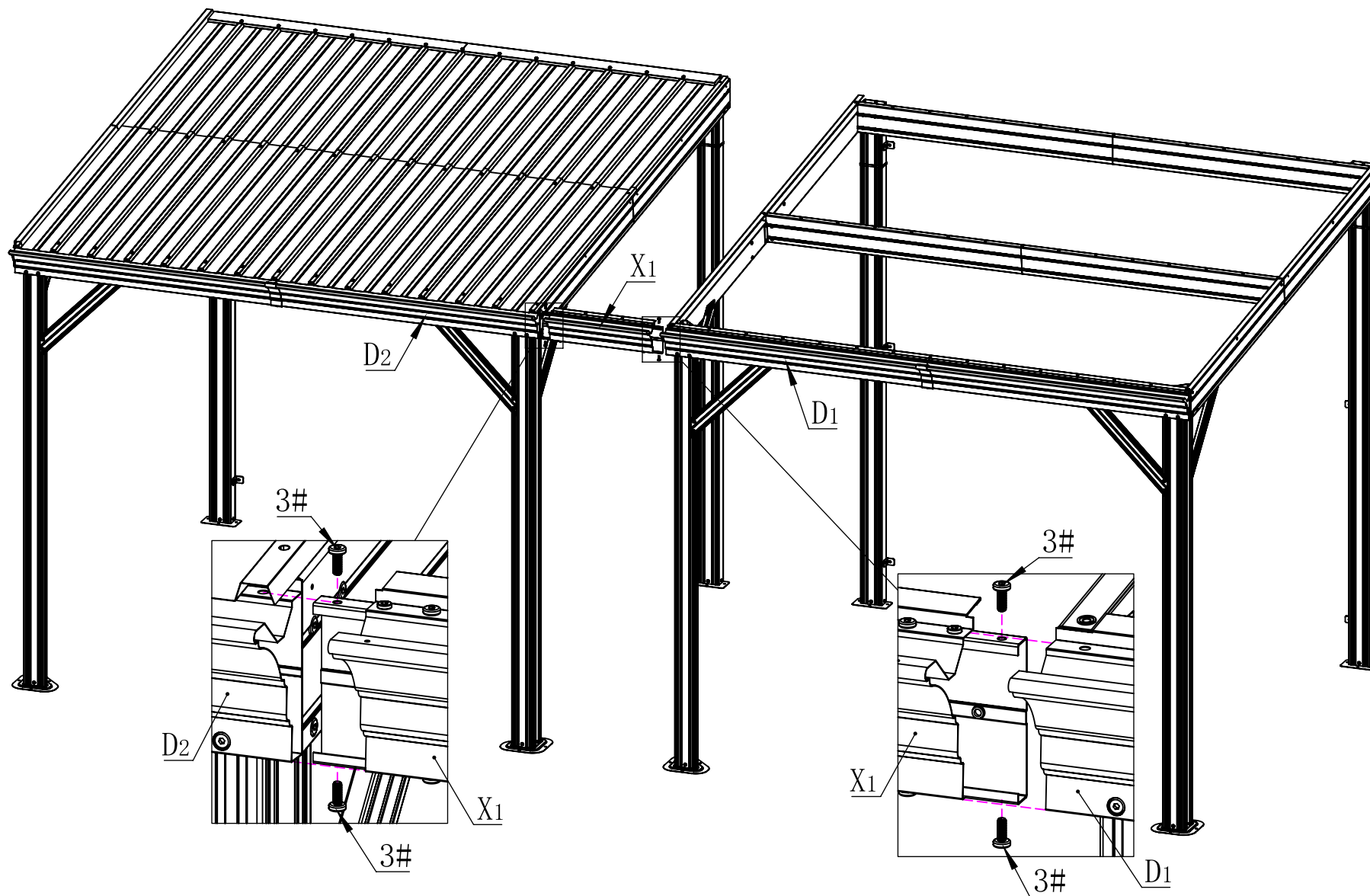

Apply silicon sealant 13# to the connection point between #D2 and #X1.

Repeat the above procedure on #D1 and #X1.

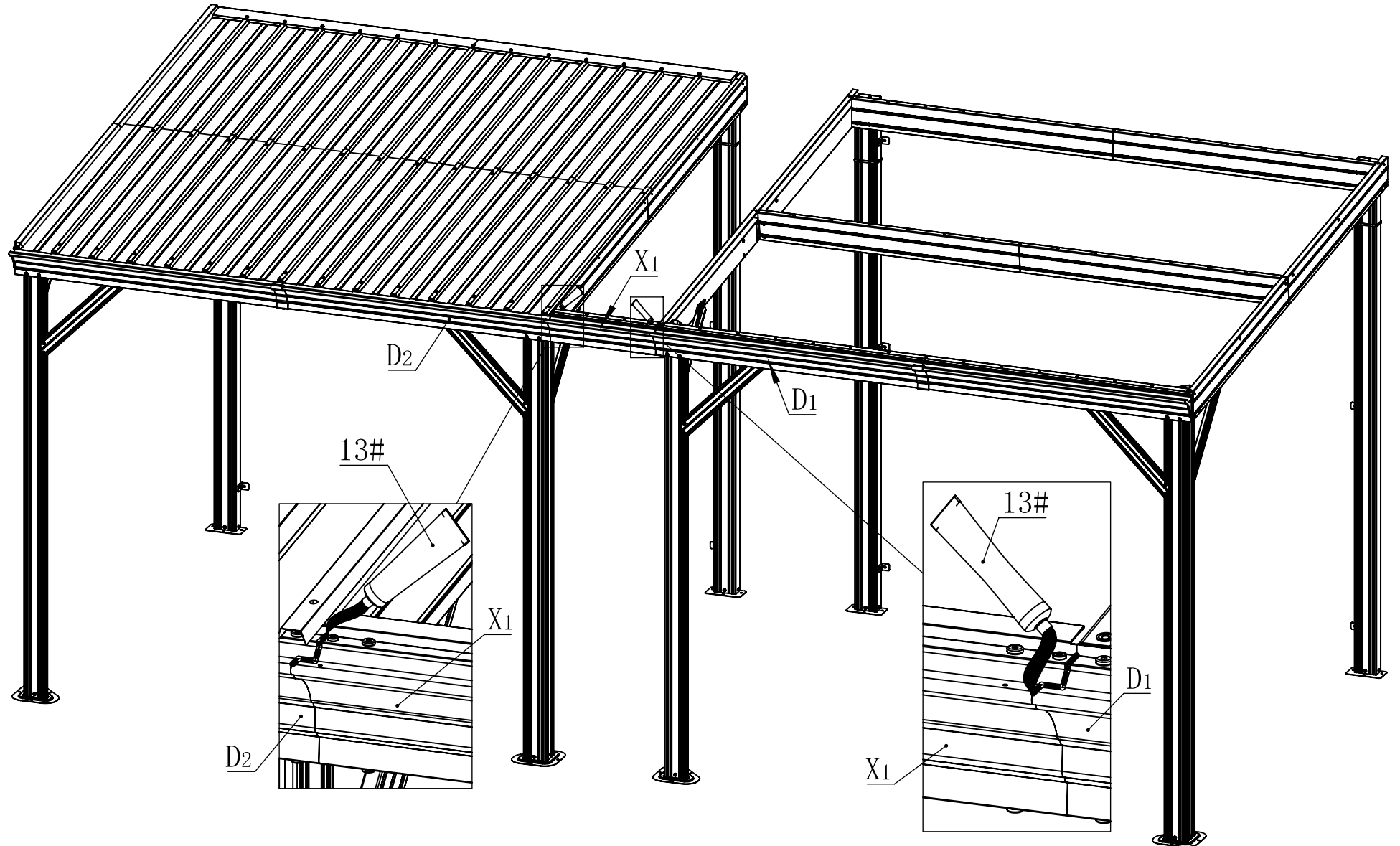

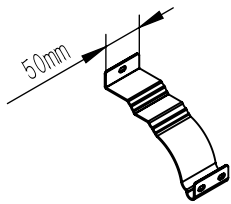

D4 2X

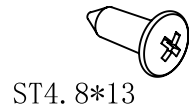

ST4, 8*13

1# 4X



M5*12

2# 2X

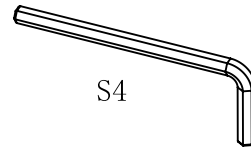

S4

8# 1X

Attach bracket #D4 to the connection point between #X1 and #D2, using screws 1# and bolts 2# to secure it.

Repeat above procedure on #D1 and #X1.

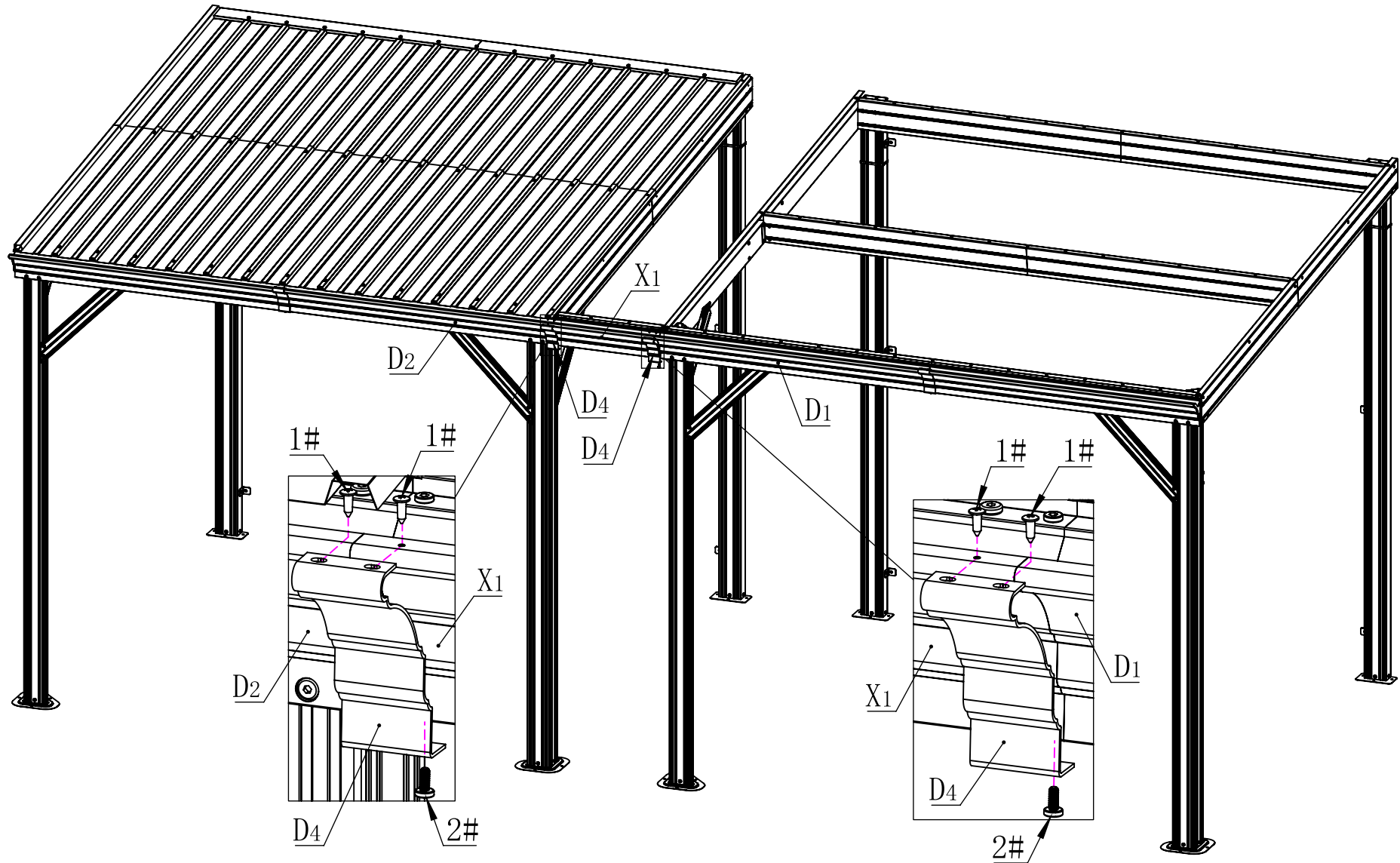

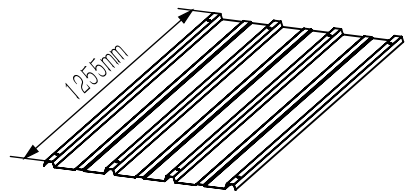

M1 1X



D12/d6. 2*H2

L1 4X

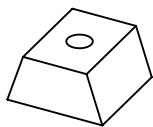

L2 4X

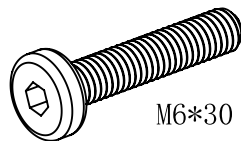

4# 4X



5# 2X

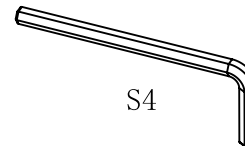

8# 1X



9# 1X

1. Place roof panel #M1 between the gap of the two gazebos and align the holes with beam X1.
2. Insert rubber spacer #L2 into the gap between #X1 and #M1.
3. Secure #X1 and #M1 with washer #L1, bolts 4# & Nuts 5#.

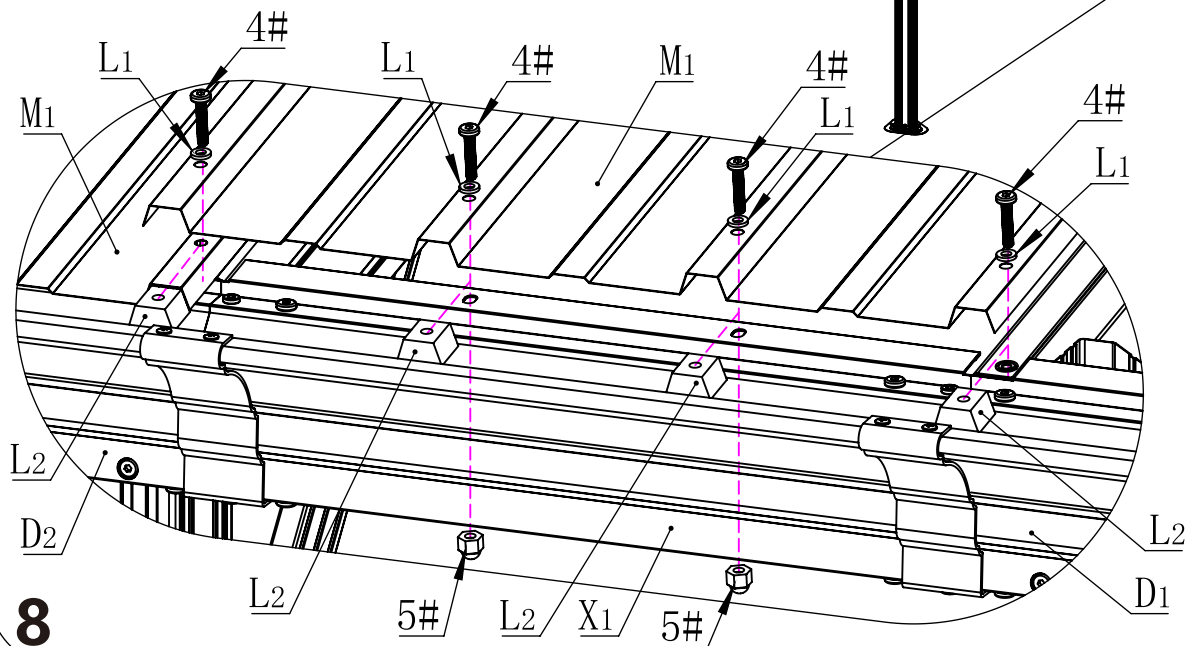
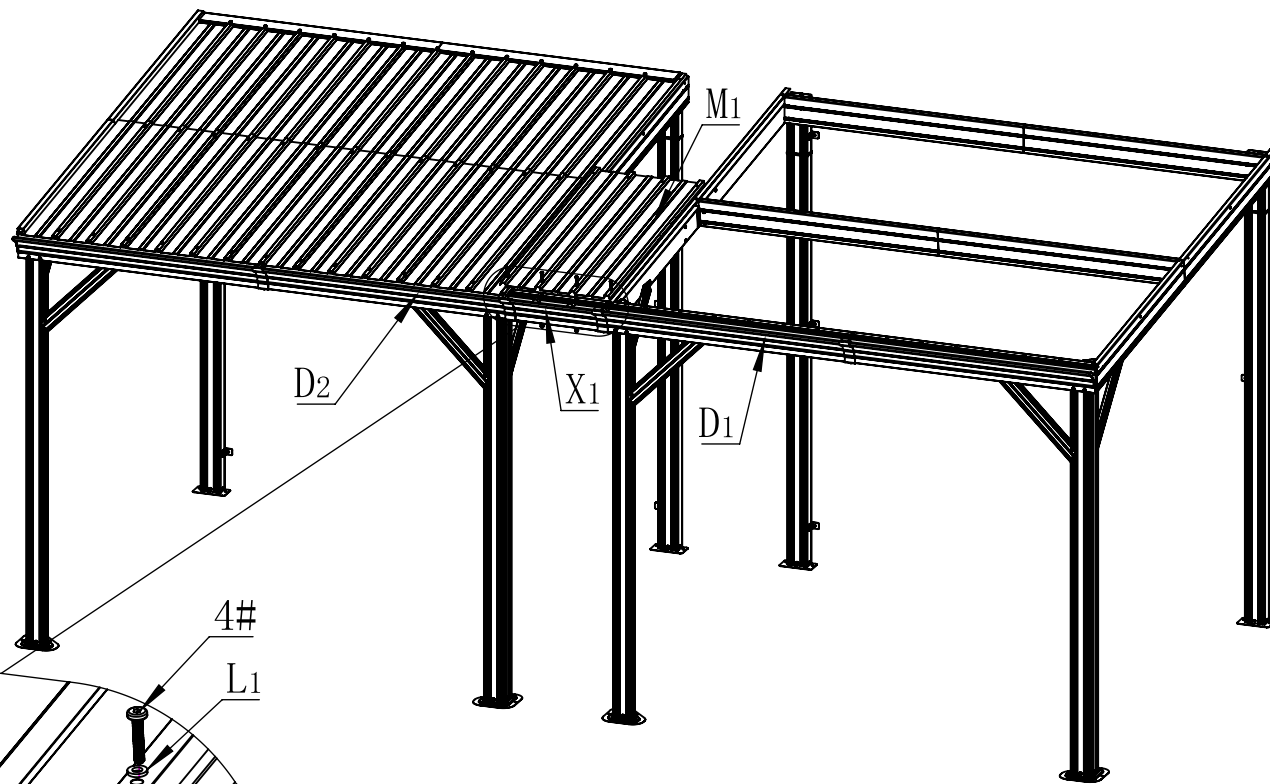

8

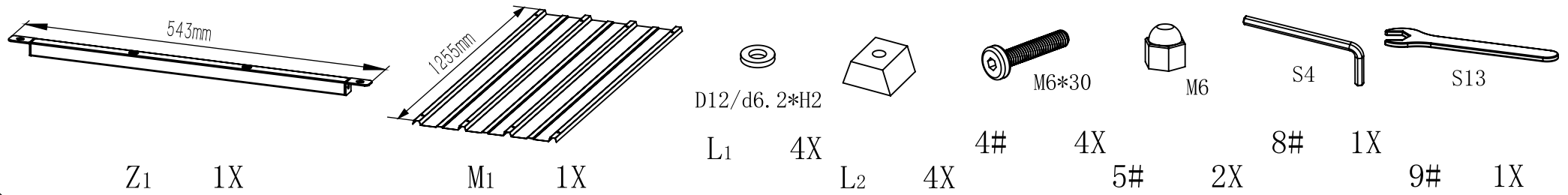

1. Please apply silicon sealant to the end of the first roof panel #M1 as shown, and then follow the instruction to install second one.

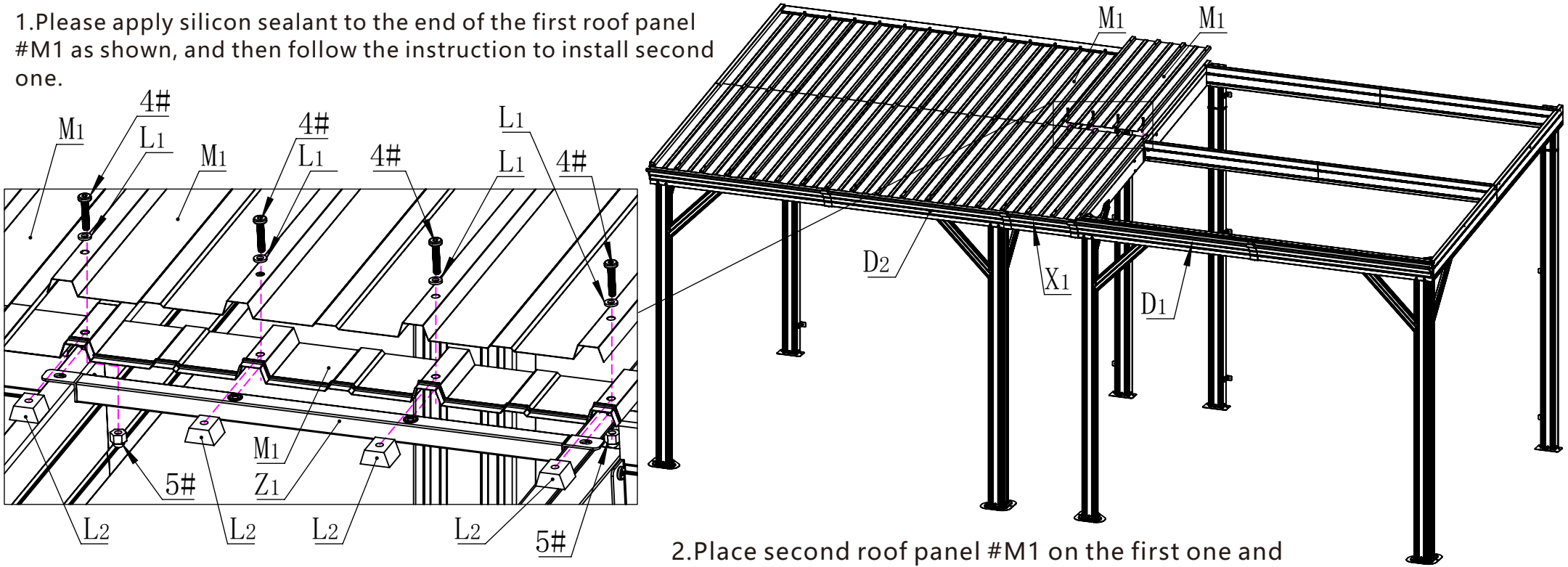

2. Place second roof panel #M1 on the first one and align the holes.

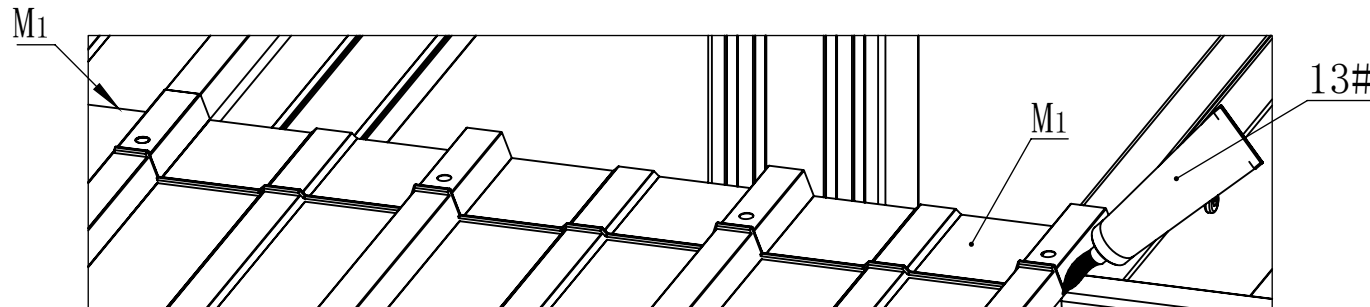

3. Place #Z1 under the first roof panel #M1 and insert rubber spacer #L2 into the gap between #Z1 and #M1.
 4. Secure #Z1 and #M1 with washer #L1, bolts 4# & Nuts 5#.

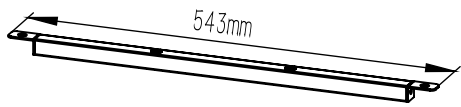

Z1 1X

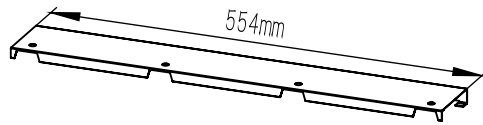

Y2 1X



L1 4X

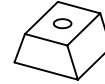

L2 4X



4# 4X

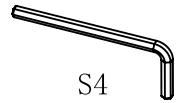

8# 1X

1. Place #Z1 under the end of second roof panel #M1 and insert rubber spacer #L2 into the gap between #Z1 and #M1.
2. Place #Y2 on the top pf #M1 roof panel and align all the holes.
3. Secure #Y2, #Z1 and #M1 with washer #L1 and bolts 4#.

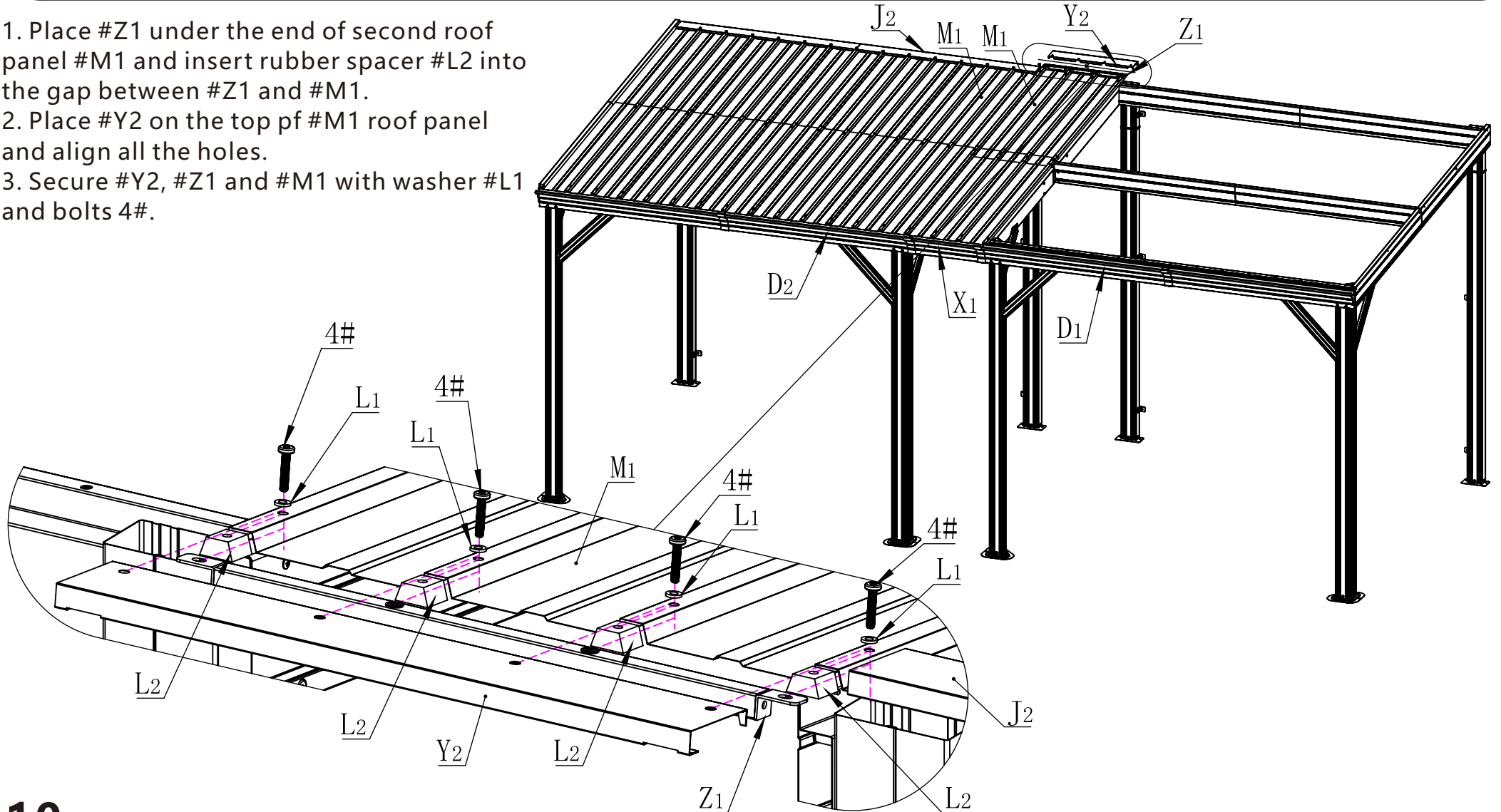

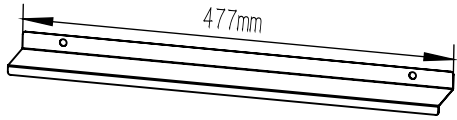

Y1 1X



6# 2X

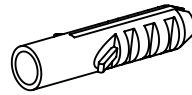

7# 2X

Insert drywall anchor 7# into the wall, attach drip rail #Y1 to the wall and secure it with screws 6#.
Apply silicon sealant #13 to the connection point of #Y1 and #J4.

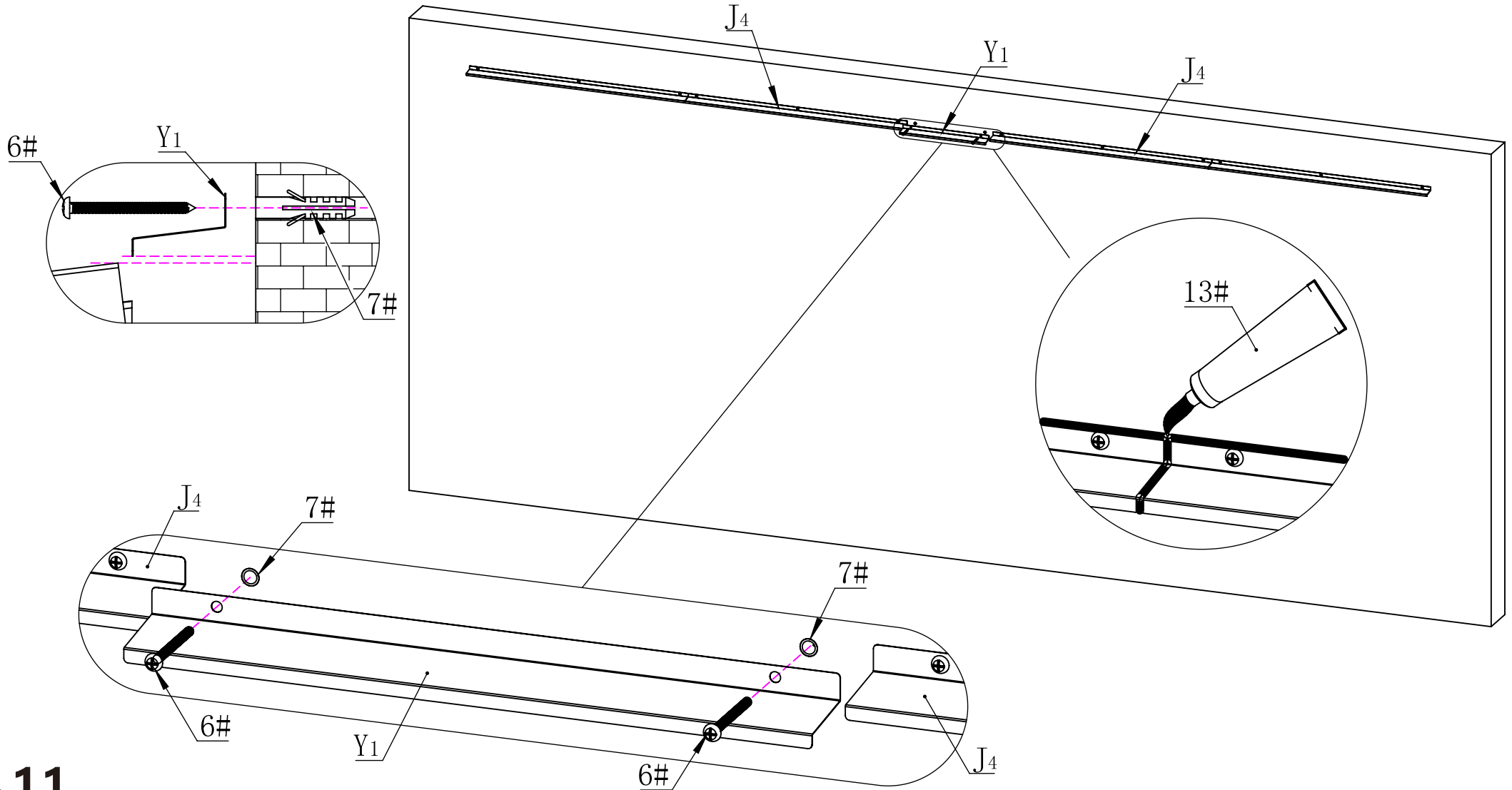

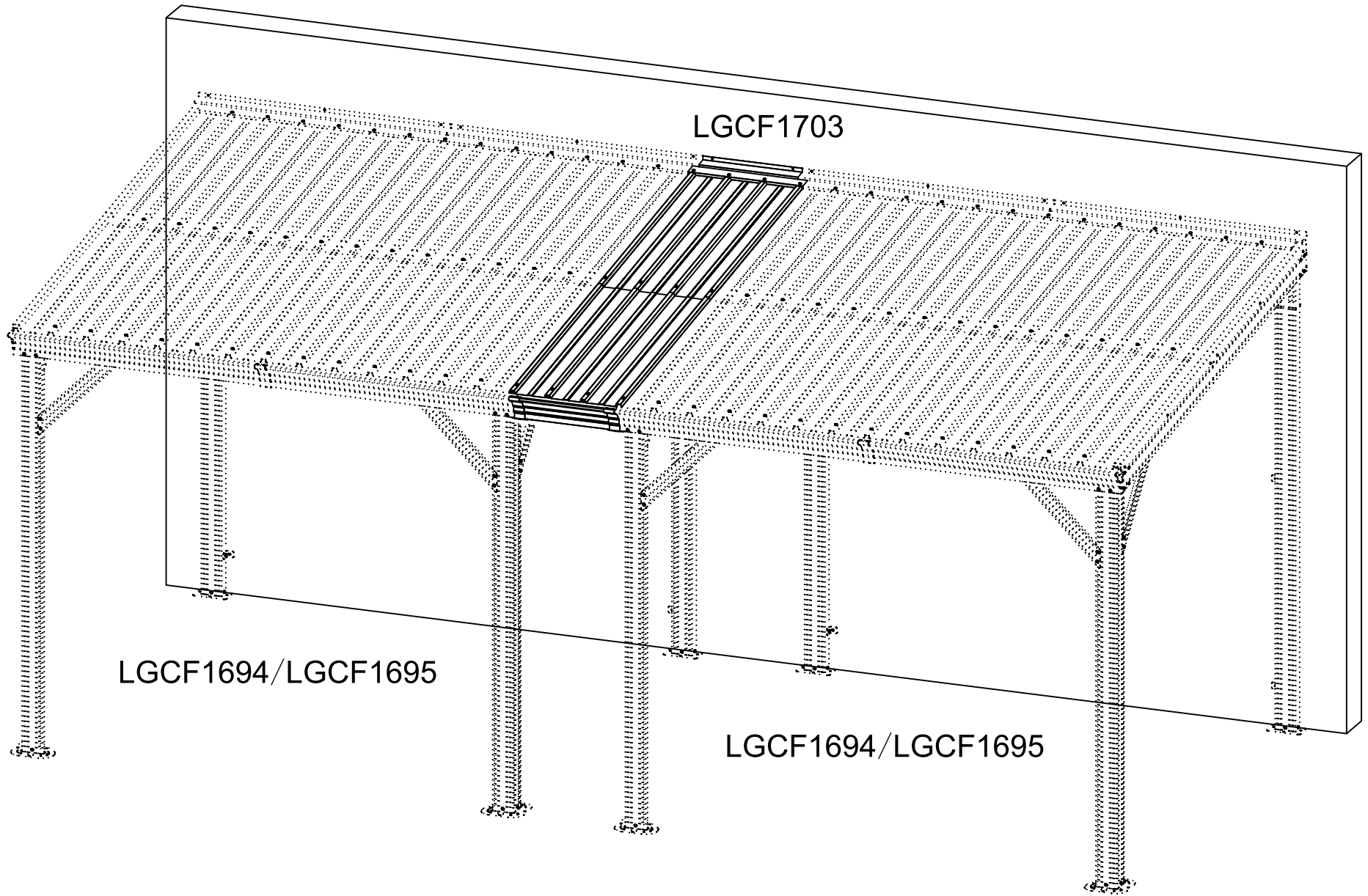



RESORT COMFORT IN YONR
OWN BACKYARD

Support:



Business cooperation contact email:

marketing@domioutdoorliving.com

After-sales contact email:

service@domioutdoorliving.com

Please tell us your order ID when contact.

Attach photos of damaged part for instant reply.