

Specifications:

Installation:	Vanity-top or drop-in
Exterior Dimensions:	30" w x 21" d x 6 1/2" h
Material:	Solid surface
Weight:	42 lbs
Overflow:	Yes
Finishes:	M - Matte white G - Gloss white
Faucet Holes:	00 - no hole 01 - one centered hole 02 - two hole - center and right, 4" spread 03 - three hole, 8" spread
Cutout size:	21" x 19" (template available upon request) 29"
Vanity Base Size:	x 20 1/2" (template available upon request)
Faucet Hole Size:	Ø 1 3/8"
Drain Hole Size:	Ø 1 3/4"



Features:

- Solid surface sink with overflow
- Solid surface drain cover
- Material is stain, scratch, chemical, and impact resistant
- Finished back
- Unfinished bottom
- Vanity bases should allow for a 1/2" overhang on front and both sides to compensate for dimensional variations of the sink top.

Codes + Standards:

- Meets and exceeds applicable national codes and standards

Recommended Items:

- Furniture
 - KUB-W-30 - Wall-mount under-counter vanity without metal trims; drawer with plumbing notch in back
 - KUB-W-30B - Wall-mount under-counter vanity without metal trims; two drawers with plumbing notch in back
 - KUB-LEG - Set of optional metal frame for vanity
 - BKS - 6" Backsplash G - gloss, M - matte
- American grid drain with overflow
 - 7100-18OF

Care + Maintenance:

- To prevent damage to the solid surface material, hot objects and open flame should not be placed in direct contact with the surface

[Click Here](#) to find out more about proper care and maintenance

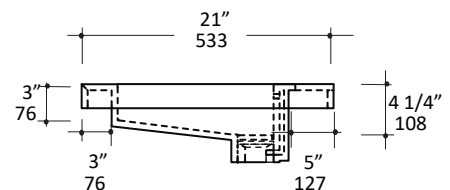
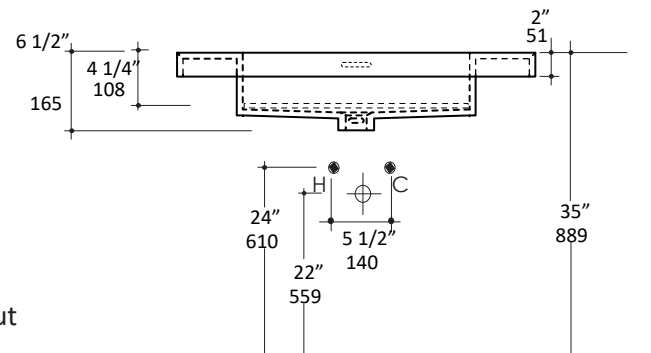
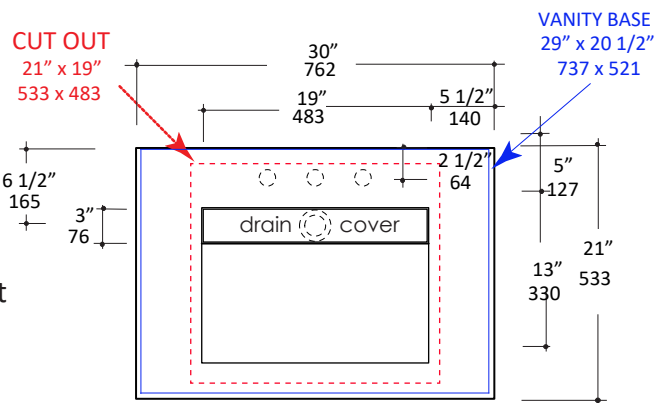

LACAVA reserves the right to revise any dimension or information on this sheet without notice. Dimensions are nominal and may vary within an industry accepted tolerance of 1/4". Drawings provided herein are meant to give the user an idea of the product and are not made to scale.

Revised: 12/12/2023