

## WARRANTY

We strive to offer high-quality products, and we do our best to satisfy each and every customer that orders from us with product or service as needed.

Each customer must provide a record of their orders such as the order number, or item receipt for any items that are out of the warranty period. You may also still receive replacement parts by purchasing them with our company if they are available.

**For return, please check the return policy with the retailer or marketplace you bought from.**

**Appreciate your purchasing from us.**

**Pop up your life by your furniture!**

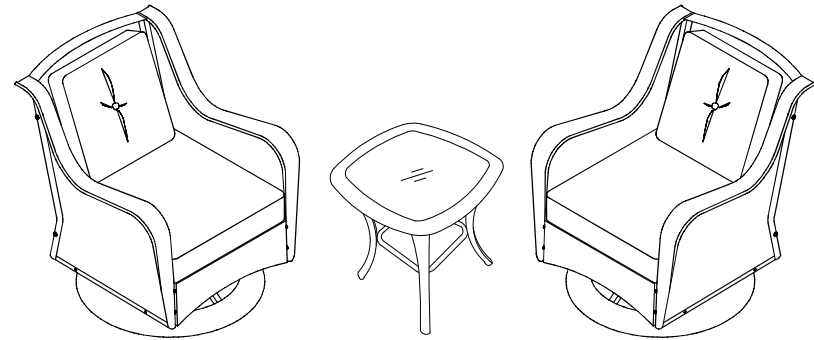

---

### NOTE:

This brochure contains IMPORTANT safety info. Please read and keep for future reference.

---

# MAINTAINANCE AND WARNING

- Keep furniture away from heat and fire.
- Keep furniture away from sharp objects.
- Do not clean furniture with harsh cleansers or polish. Do not use detergents, Solvents, abrasives, spray packs or leather cleaners. Use non-color mild soap with warm water to clean spills (Mix 1:10 soap to water)
- Do not place furniture under direct sunlight, material will possibly fade over time.
- Do not jump or strike on furniture.
- Do not write on furniture without a padded barrier to protect the surface.
- Not for commercial use, For residential use only.



Weight Limitation

**400LBS**

# PARTS LIST

A1\*2



Left Arm

A2\*2



Right Arm

B\*2



Back

C\*2

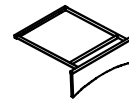

Seat

D\*2



U-shaped Fitting

E\*2



Chair Base

F\*2

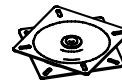

Swivel

G\*2

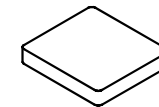

Seat Cushion

H\*2



Back Cushion

I\*4



Table Leg

J\*1

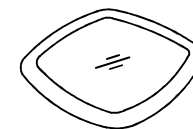

Table Top

K\*1

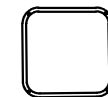

Table Tray

# HARDWARE and TOOL LIST

①\*16



Spring washer

②\*64

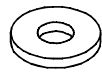

Washer

③\*24



Nut

④\*8

M6\*15mm



Bolt

⑤\*36

M6\*35mm

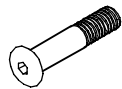

Bolt

⑥\*12

M6\*12mm



Bolt

⑦\*1

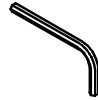

Allen Wrench

⑧\*1



Open end Wrench

## SPARE

④\*1

M6\*15mm



Bolt

⑤\*1

M6\*35mm



Bolt

⑥\*1

M6\*12mm



Bolt

**Be sure to check all packing materia fit the packing list. Carefully for small parts, which may have come loose inside the carton during shipment.**

# ASSEMBLY INSTRUCTIONS

(X2)

STEP 1

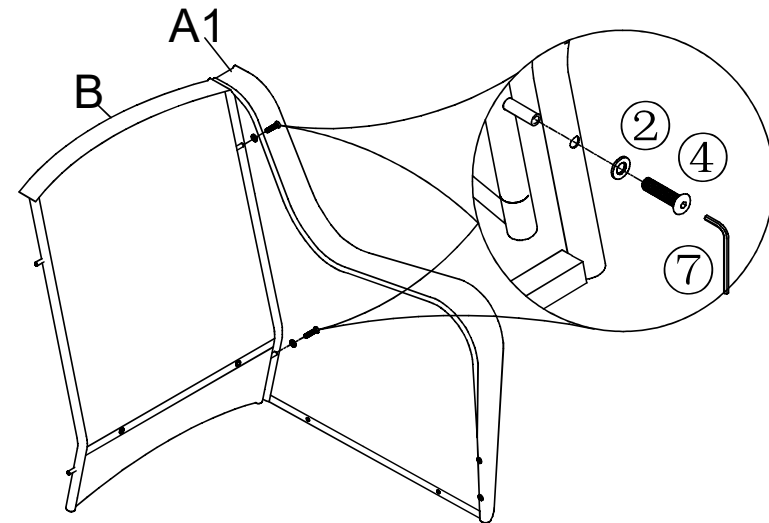

STEP 2

(X2)

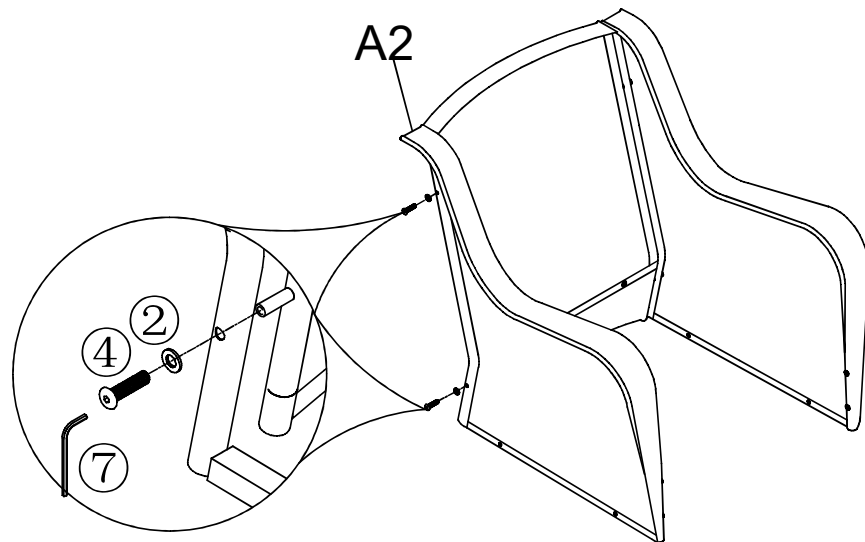

STEP 3

(X2)

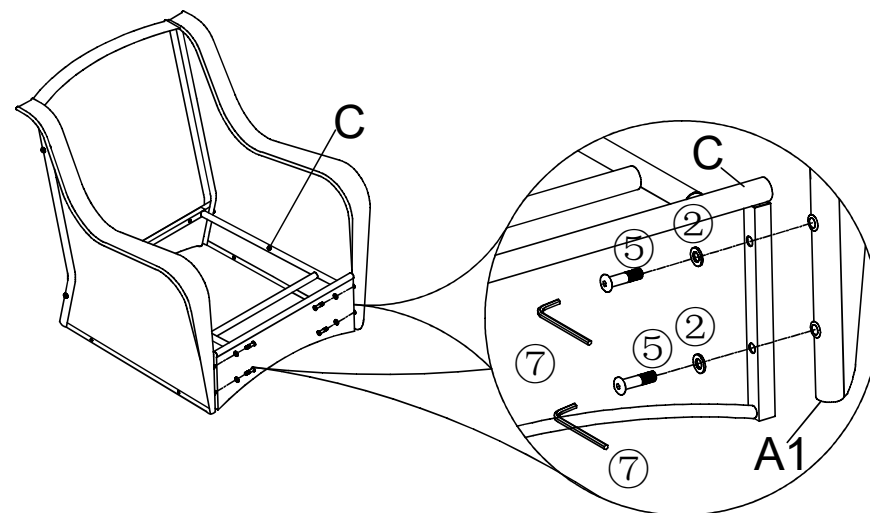

STEP 4

(X2)

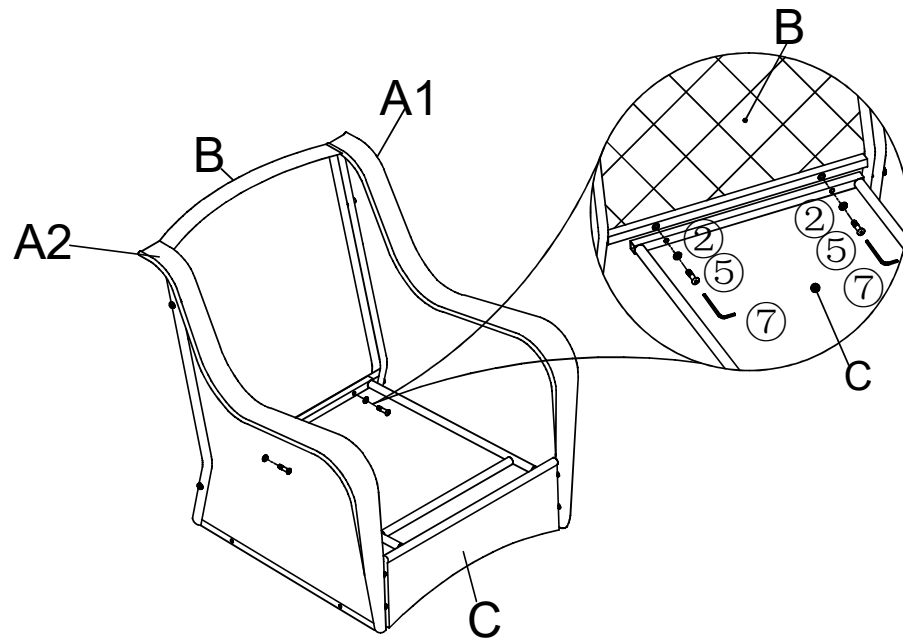

STEP 5

(X2)

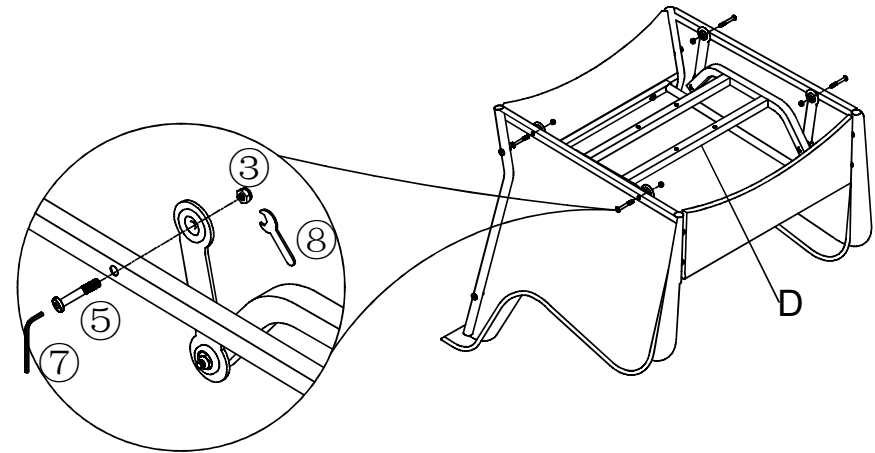

STEP 6

(X2)

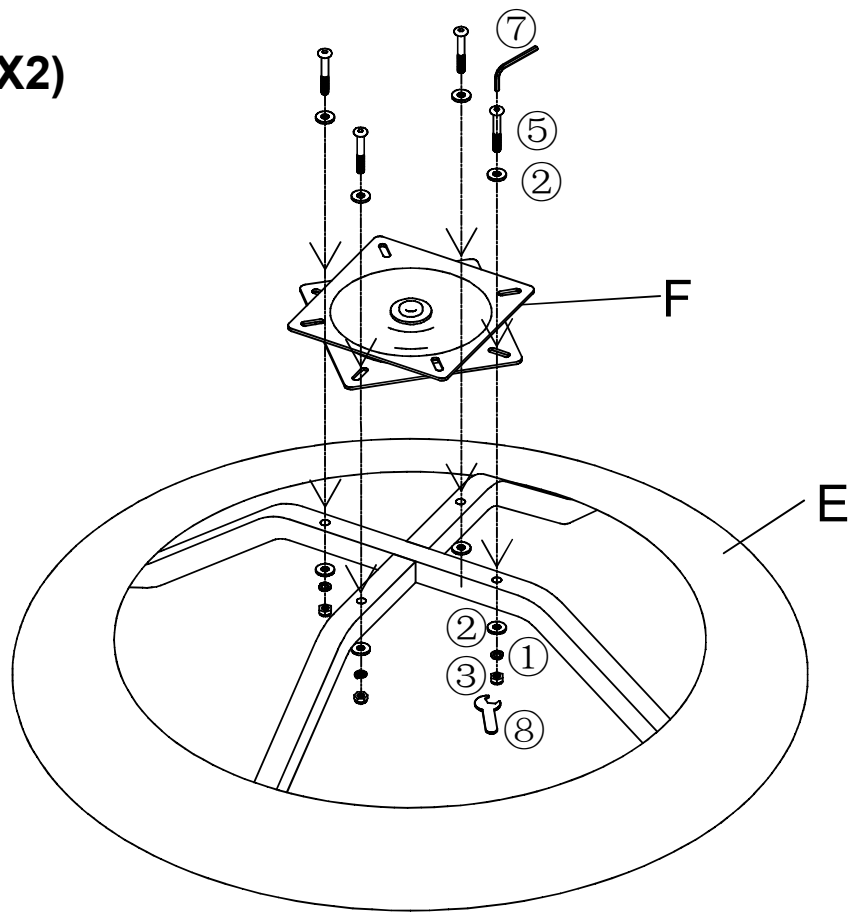

STEP 7

(X2)

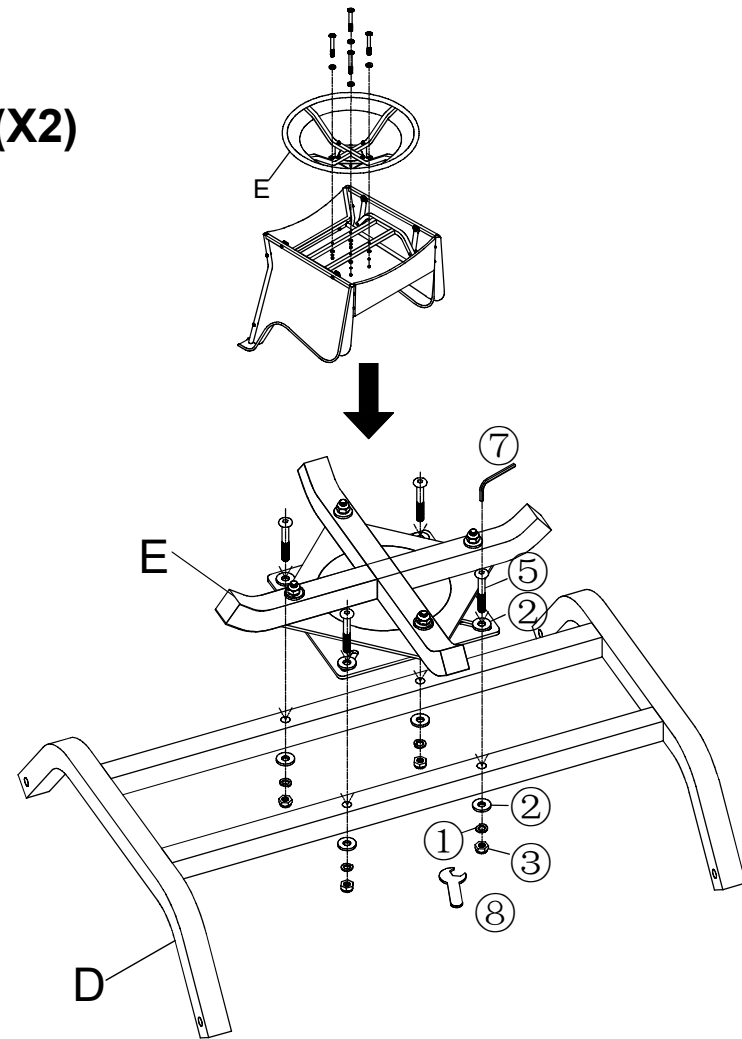

**STEP 8**

**(X2)**

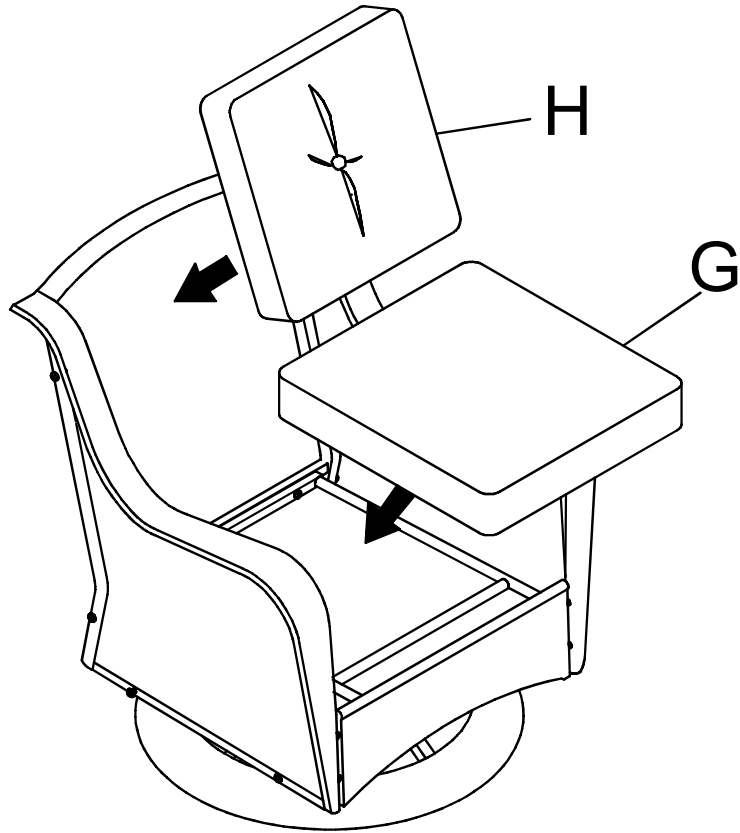

**STEP 9**

**(X2)**

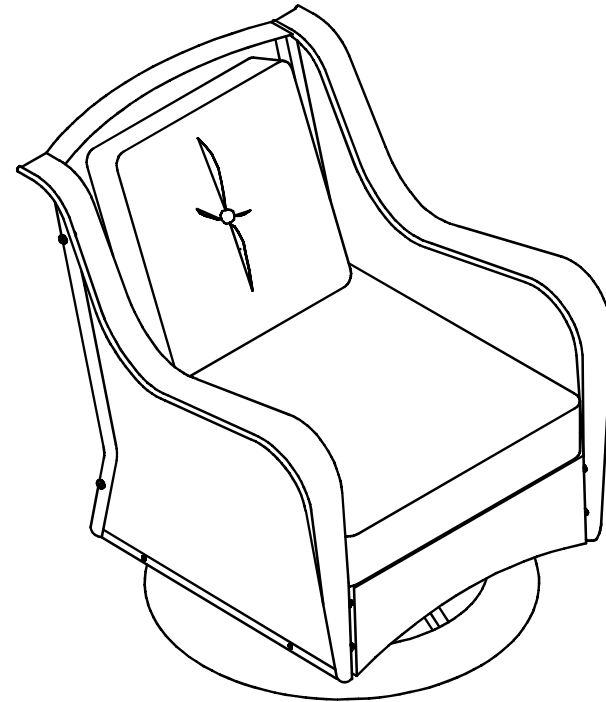

### STEP 10

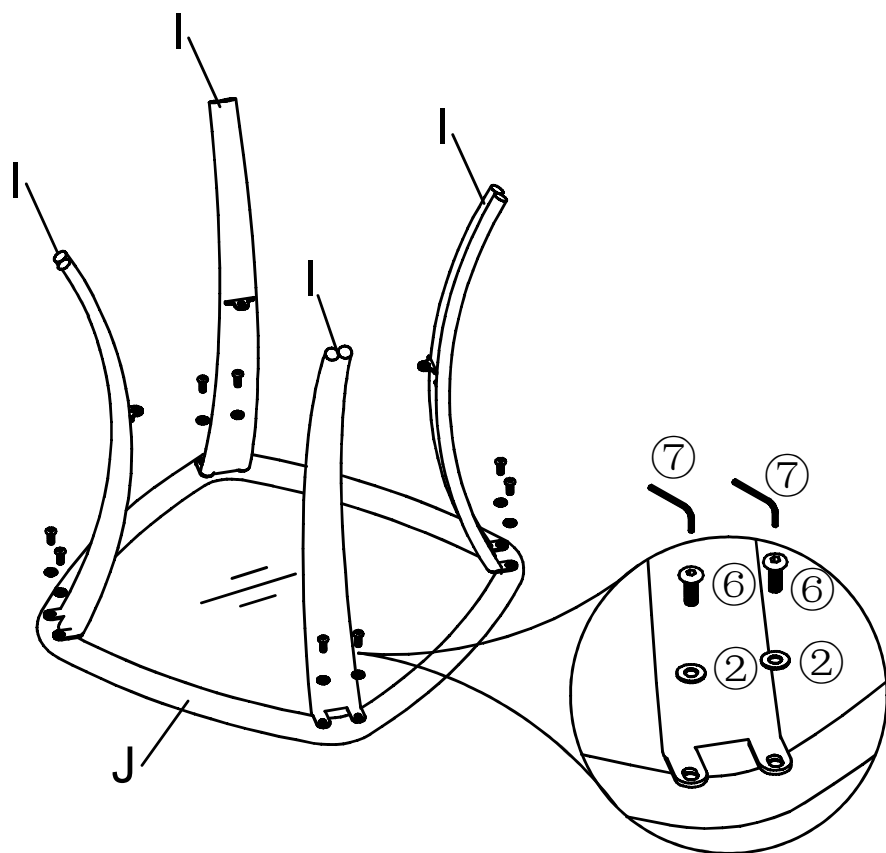

### STEP 11

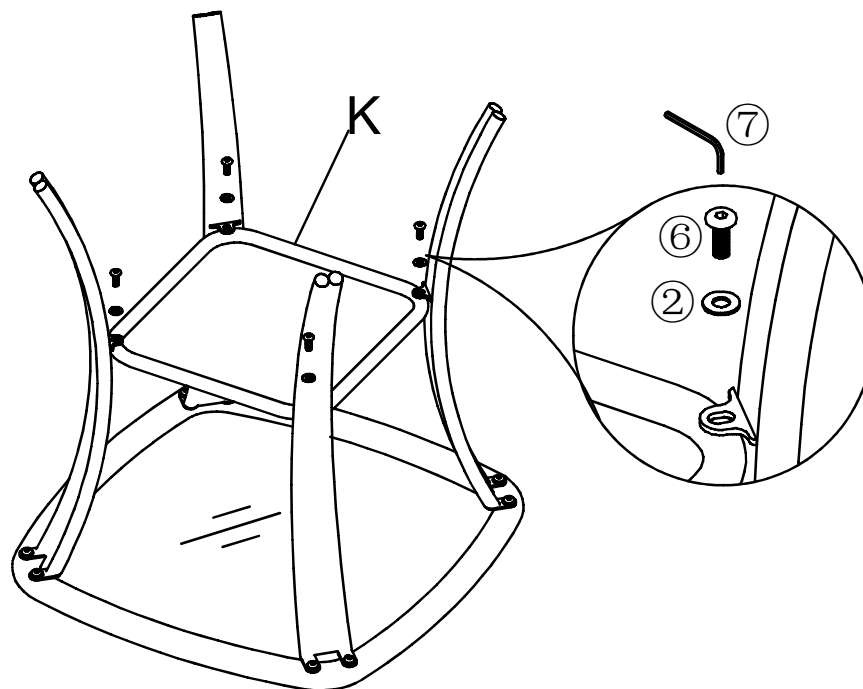

**STEP 12**

