

ASSEMBLY INSTRUCTIONS



END TABLE

ASSEMBLY INSTRUCTIONS

ASSEMBLY TIPS:

1. Remove hardware from box and sort by size.
2. Please check to see that all hardware and parts are present prior to start of assembly.
3. Please follow attached instructions in the same sequence as numbered to assure fast & easy assembly.



WARNING!

1. Don't attempt to repair or modify parts that are broken or defective. Please contact the store immediately.
2. This product is for home use only and not intended for commercial establishments.



ASSEMBLY TIME

30 MINUTES

PARTS IDENTIFICATION

A LEFT SIDE PANEL 1 PC

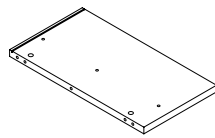

B RIGHT SIDE PANEL 1 PC

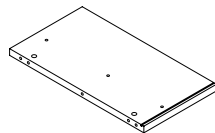

C BOTTOM PANEL 1 PC

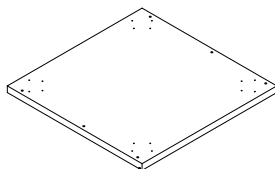

D CROSS PANEL 1 PC

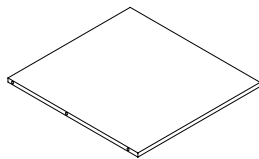

E TOP PANEL 1 PC

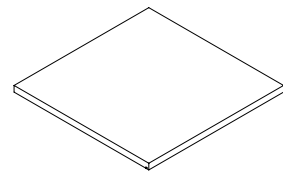

F BACK PANEL 1 PC

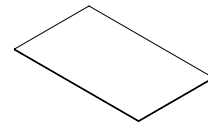



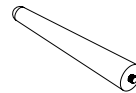

G LEG 4 PCS

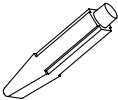

NOTE:

Phillips head screw driver is required in the assembly process; however, manufacturer does not provide this item.

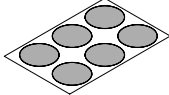
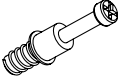
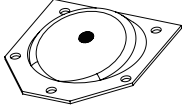
HARDWARE IDENTIFICATION

Z							
NO	DESCRIPTION	FIGURE	Q'TY	NO	DESCRIPTION	FIGURE	Q'TY
1	GLUE 15g		1 PC	5	SCREW Ø4.5x42mm SR		6 PCS
2	WOODEN DOWEL Ø8x30mm		16 PCS	6	STICKER Ø20mm		1 PC
3	CAM BOLT Ø7x35.5mm SR		4 PCS	7	SPACER SR		4 PCS
4	CAM LOCK Ø15x12mm SR		4 PCS	8	SCREW Ø4x15mm SR		16 PCS

NOTE:

Phillips head screw driver is required in the assembly process; however, manufacturer does not provide this item.

STEP 1

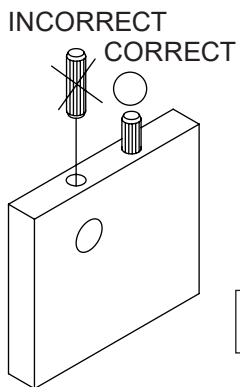
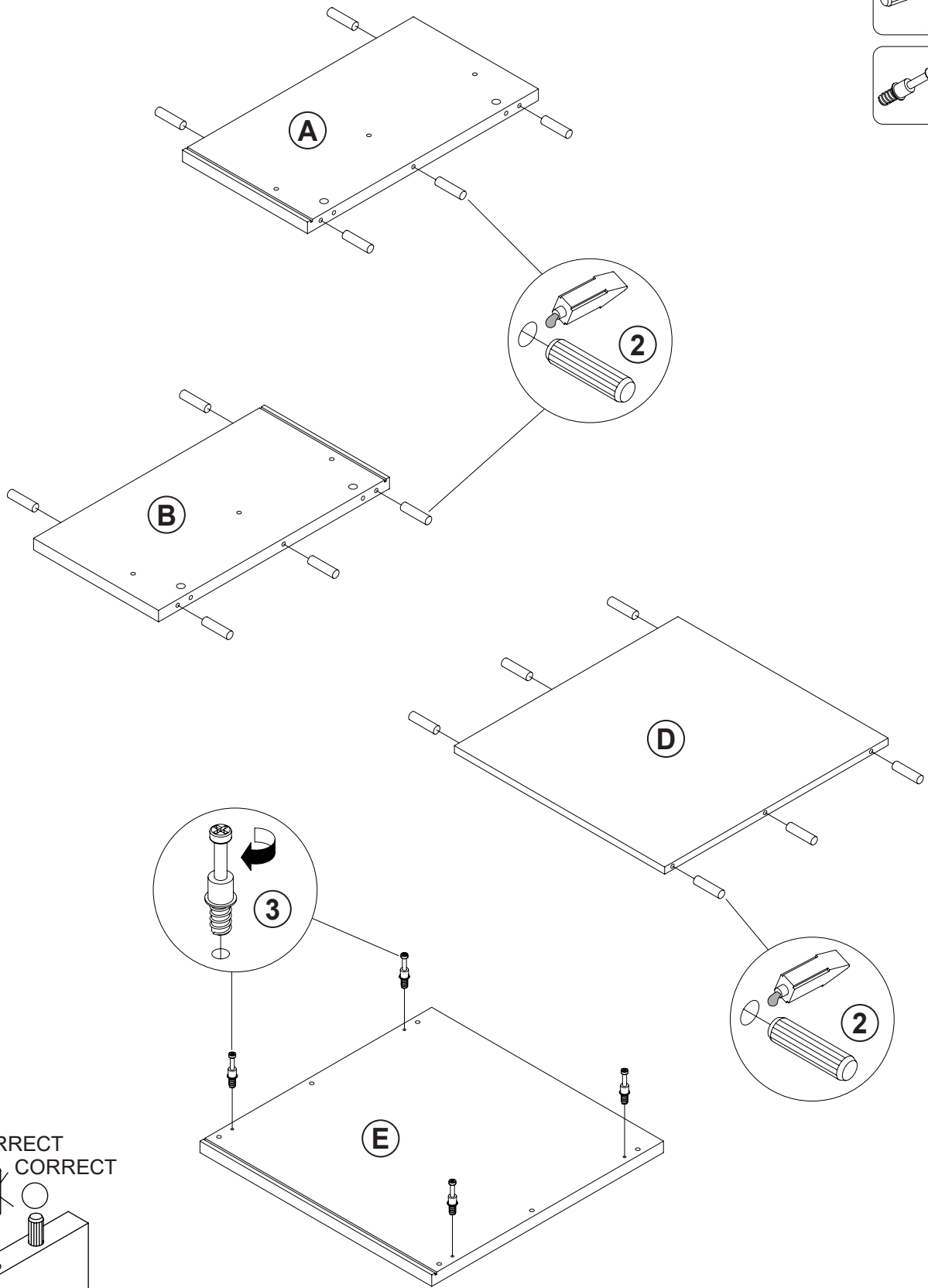
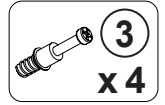
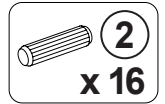

Apply glue on all wooden dowels to ensure integrity of the structure.

STEP 2

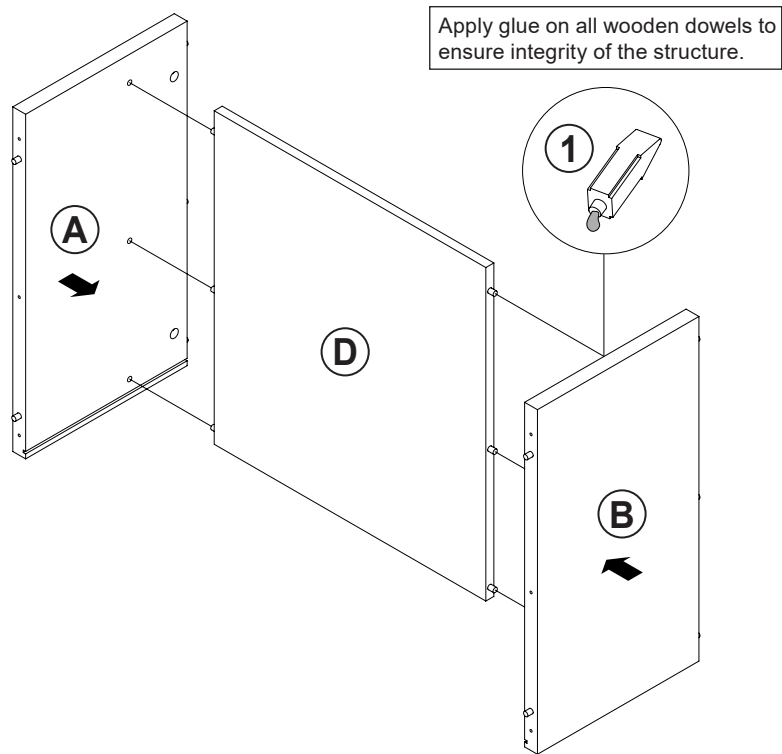

STEP 3

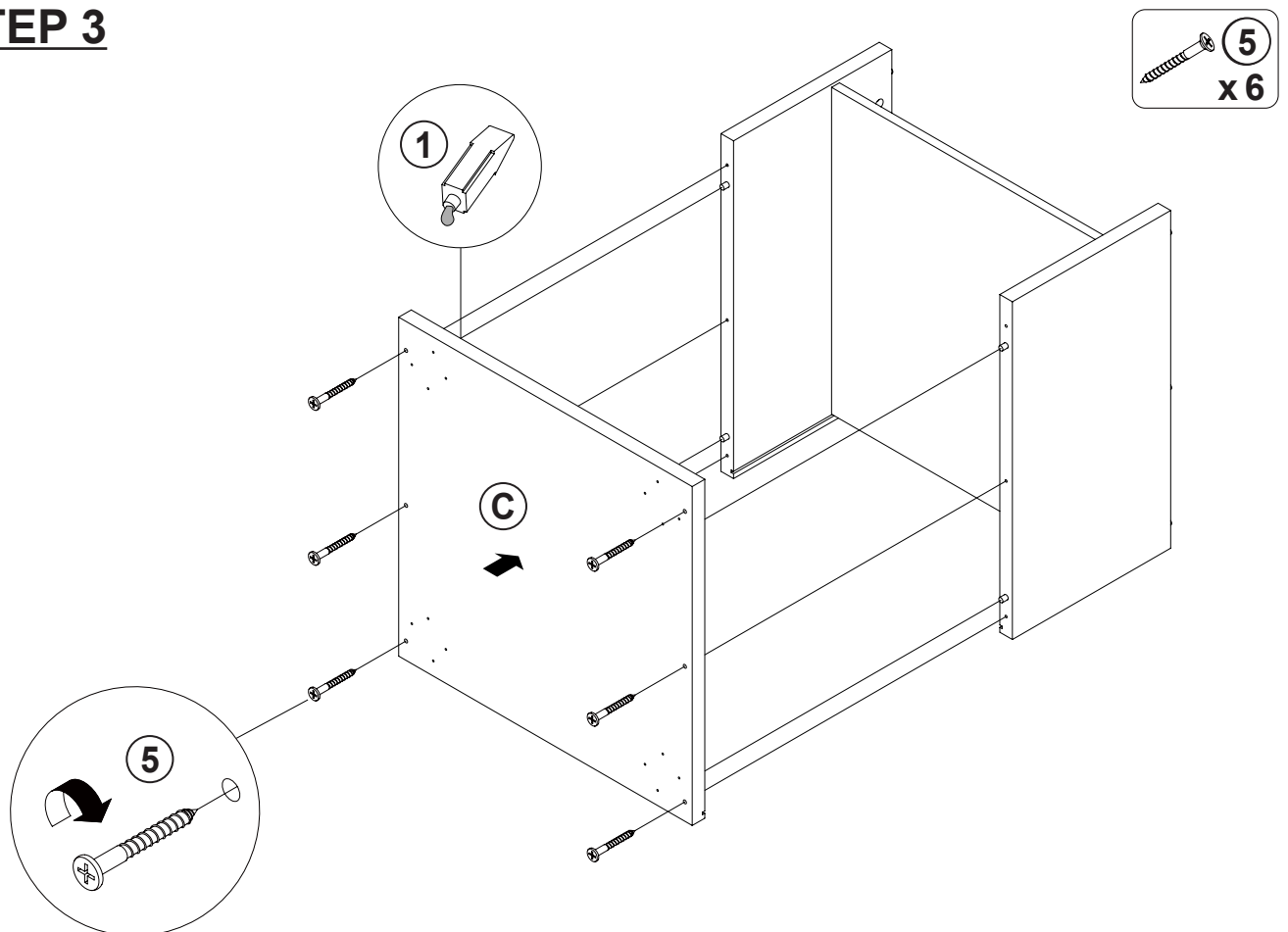

STEP 4

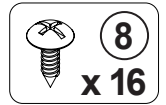
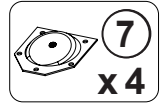
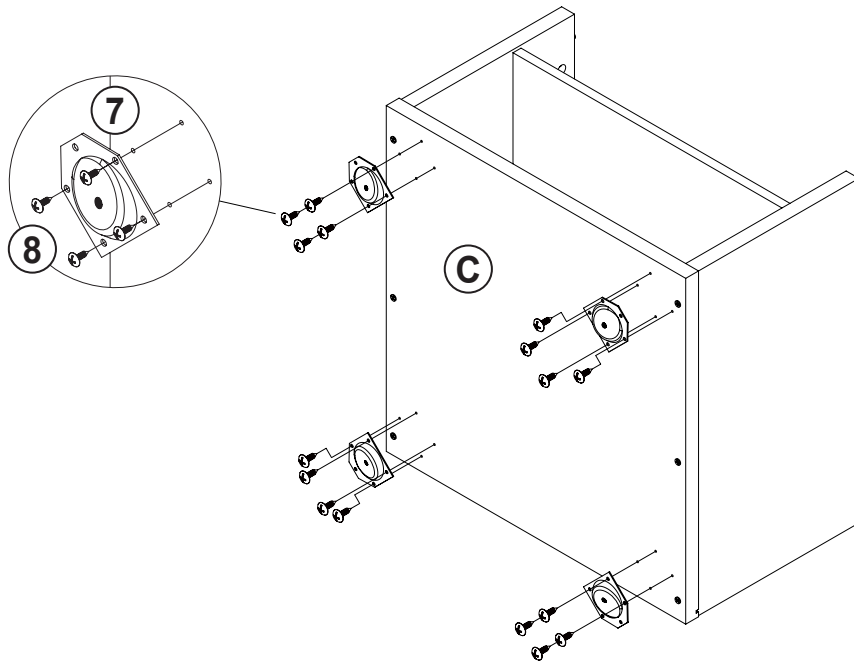

STEP 5

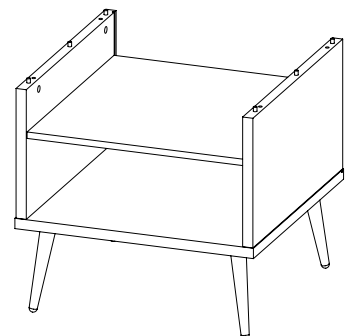
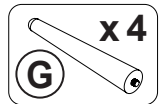
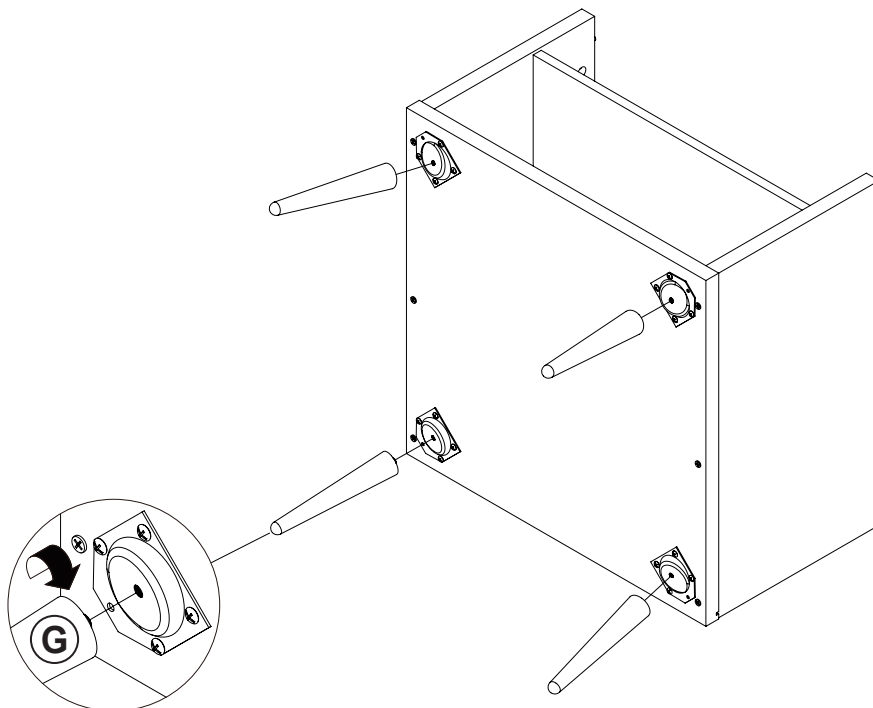

STEP 6

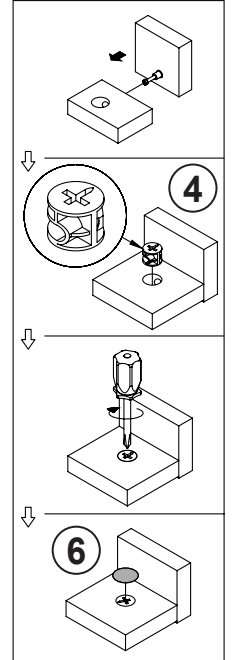
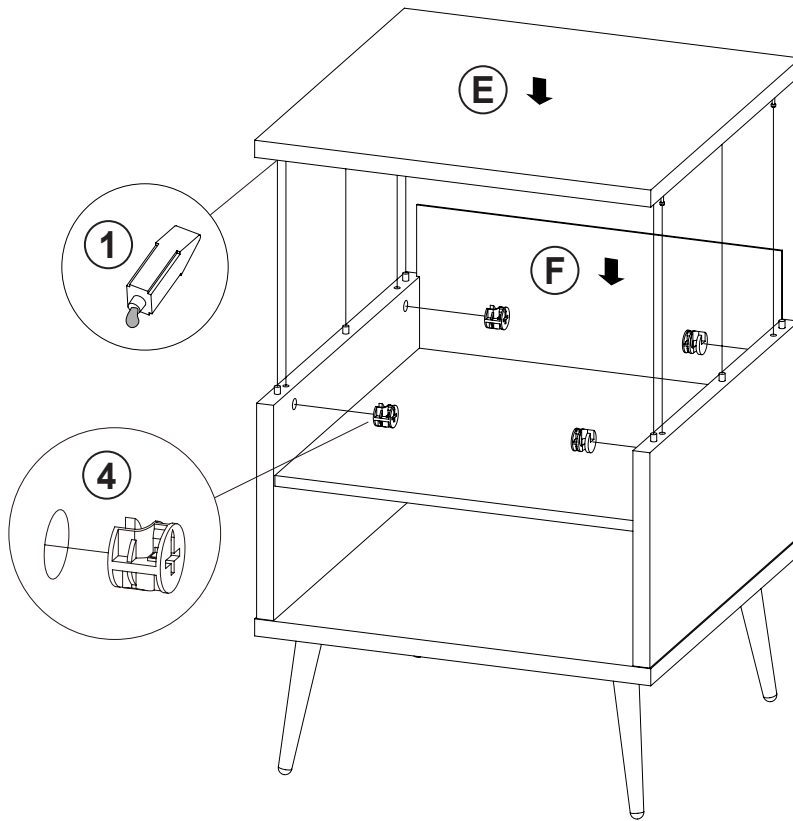
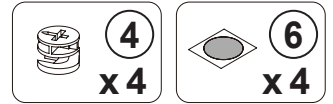

STEP 7 COMPLETE

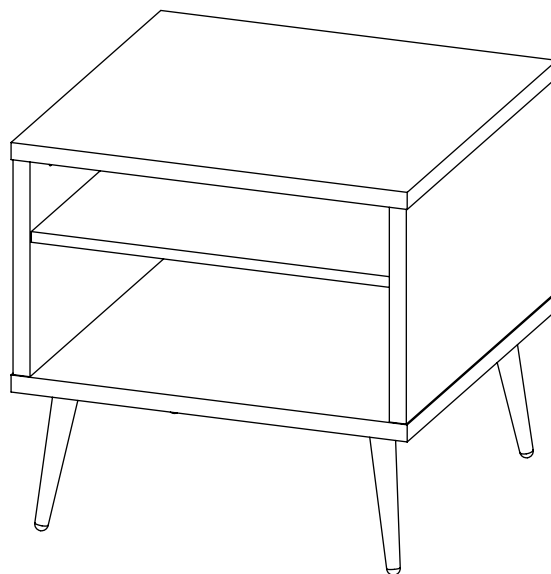

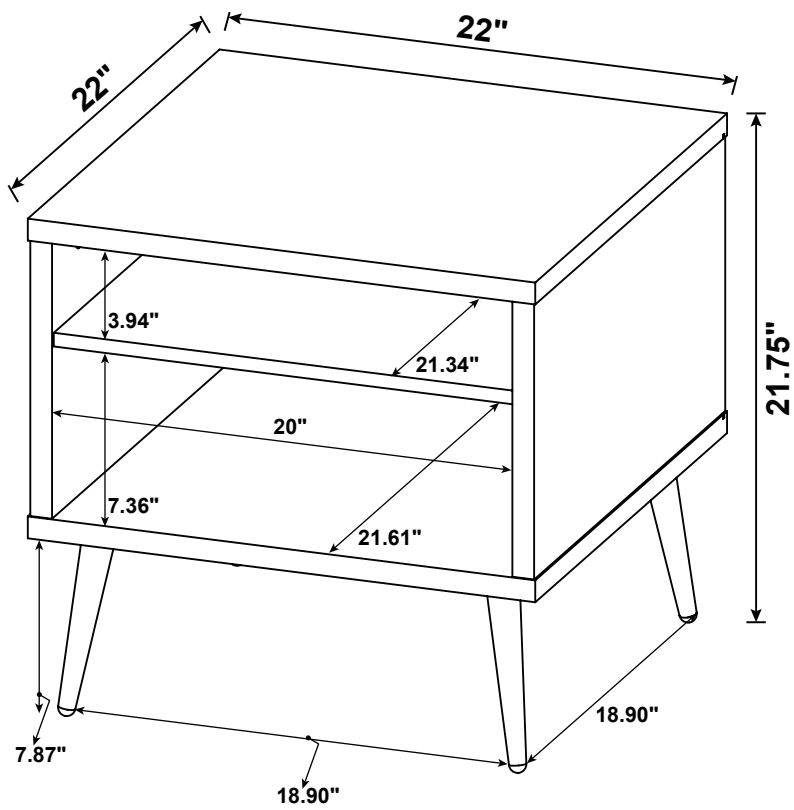

Note : Dimension tolerance $\pm 5\%$