

















ASSEMBLY INSTRUCTION

ITEM : 30009-211/30010-21

NO	PARTLIST		QTY
1		BACK REST	1PC
2		SIDE PANEL (L)	1PC
3		SIDE PANEL (R)	1PC
4		BOX SEAT	1PC
5		LEG	2PCS
6		LEG (L)	1PC
7		LEG (R)	1PC
ITEM	HARDWARE		QTY
A		JCBC SCREW M8 x 35mm	2PCS
B		JCBC SCREW M8 x 50mm	16PCS
C		JCBC SCREW M6 x 20mm	6PCS
D		SPRING WASHER M8 x 13mm	18PCS
E		FLAT WASHER M8 x 22mm	18PCS
F		SPRING WASHER M6 x 12mm	6PCS
G		FLAT WASHER M6 x 13mm	6PCS
H		L - KEY M4 x 65mm	1PC
I		L - KEY M5 x 65mm	1PC

STEP 1

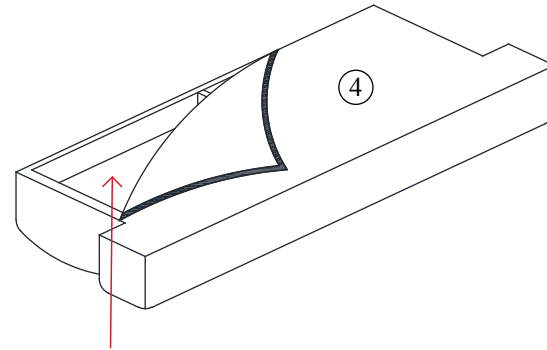

Get all others parts from compartment of seat body.

STEP 2

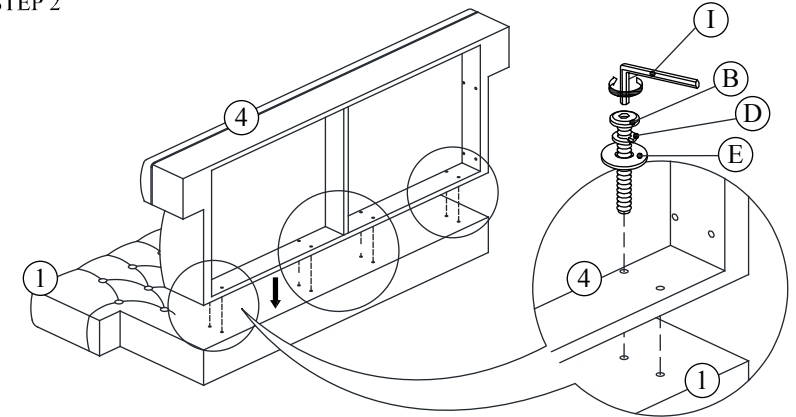

STEP 3

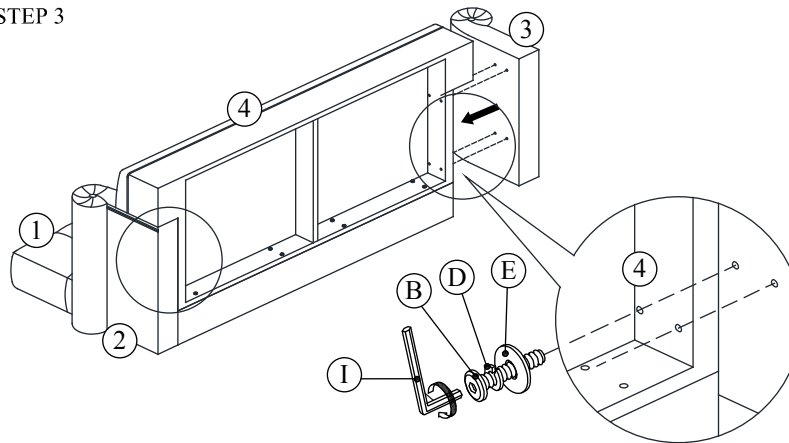

STEP 4

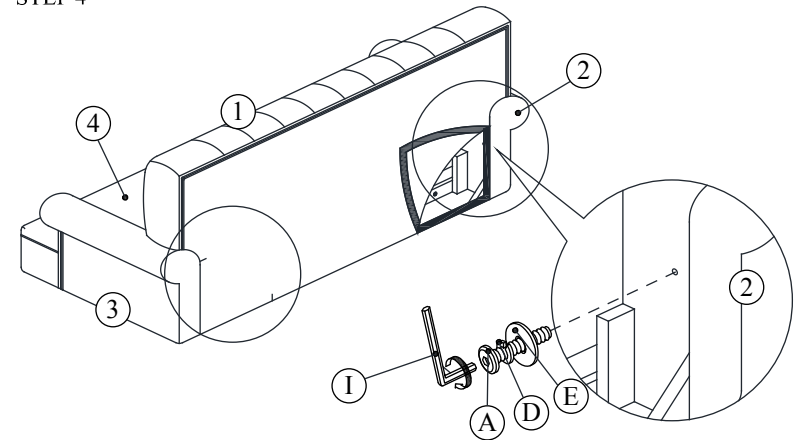

STEP 5

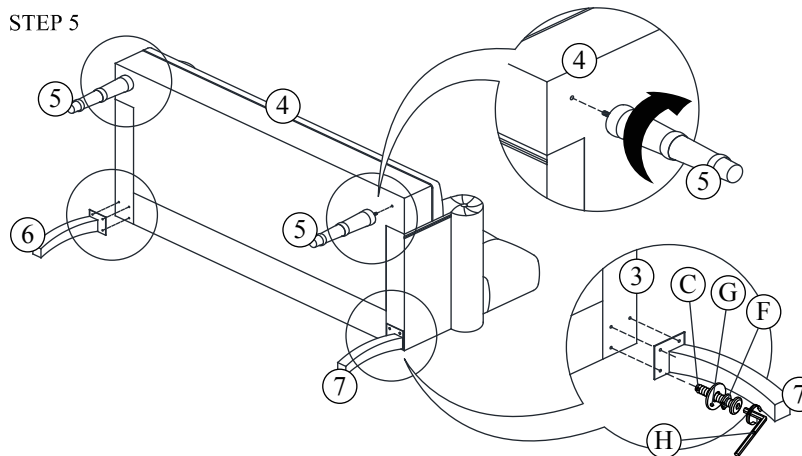

STEP 6

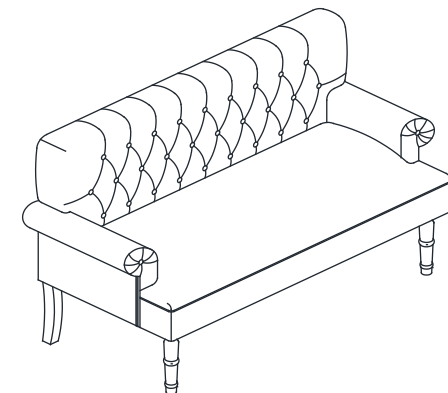

ASSEMBLY
COMPLETED