

Assembly Instructions

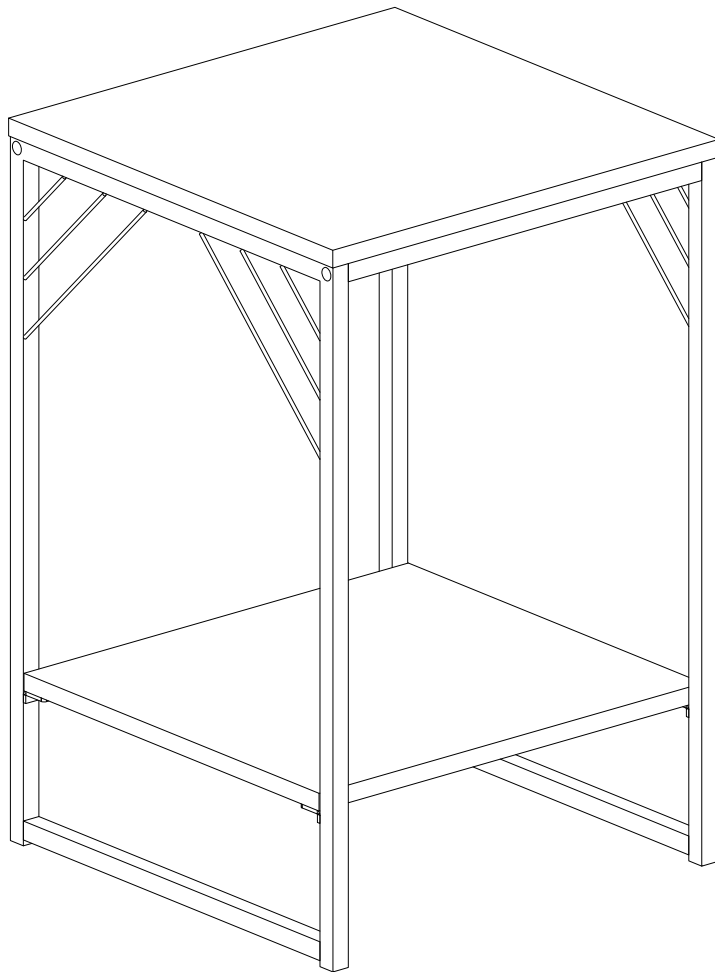

General Assembly Guidelines

- I. Ensure that all parts and hardware are available before beginning assembly.
- II. Follow each step carefully to ensure the proper assembly of this product.
- III. Two people are recommended for ease in the assembly of this product.
- IV. The main type of hardware used to assemble this product are: bolts and screws.
- V. Power tools should not be used to assemble this product.

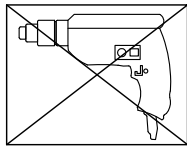

- VI. Drill may be needed for securing product to wall.

Parts List

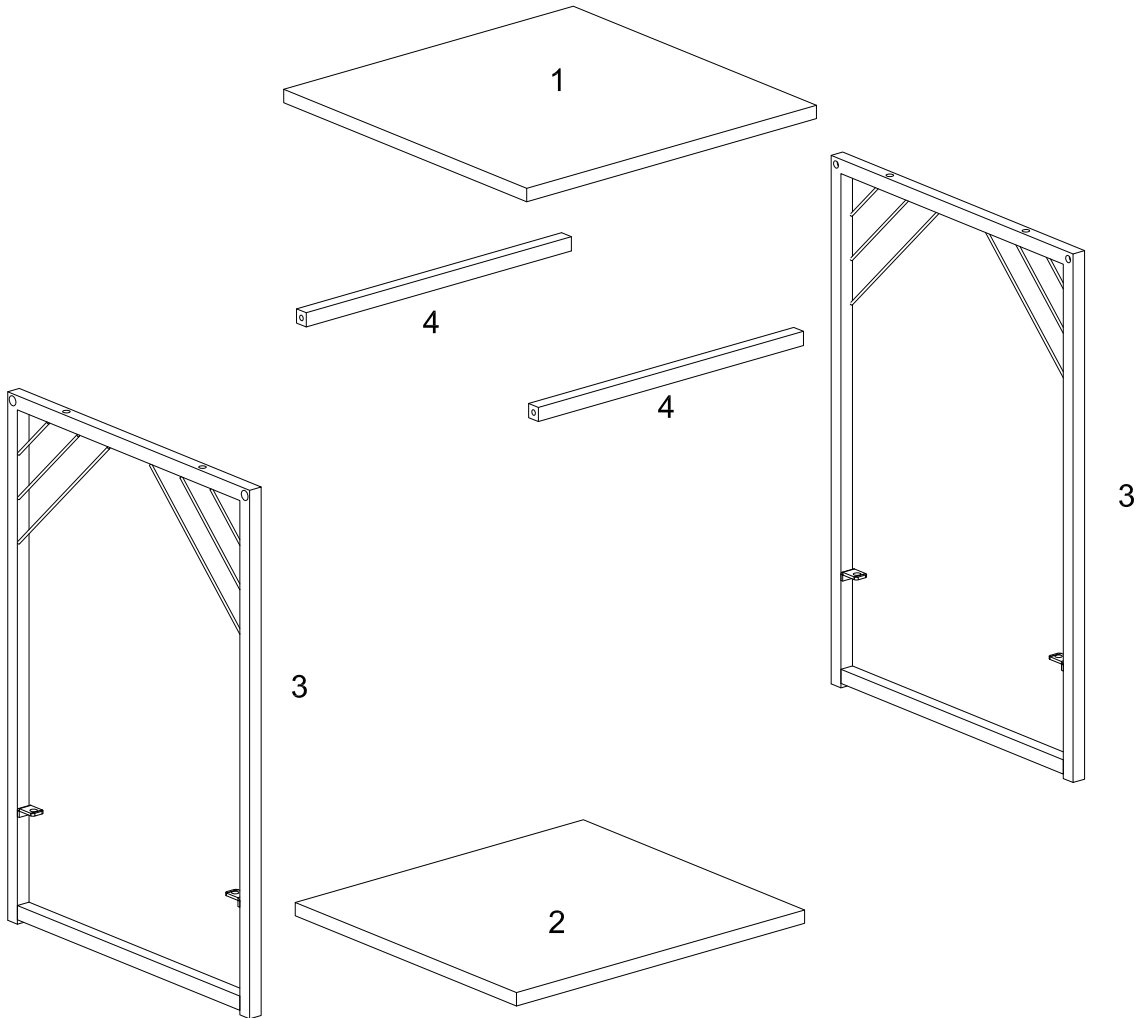

Hardware List

A		M6x25mm	Bolt	4 pcs
B		M6x12mm	Bolt	4 pcs
C		M6x30mm	Bolt	4 pcs
D		M4	Hex Key	1 pc

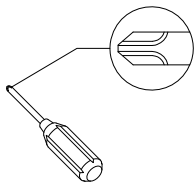

Philips head screwdriver required for assembly
(not included)

*The hardware quantities listed above are required for proper assembly.
Some extra hardware may also have been included.*

Step 1

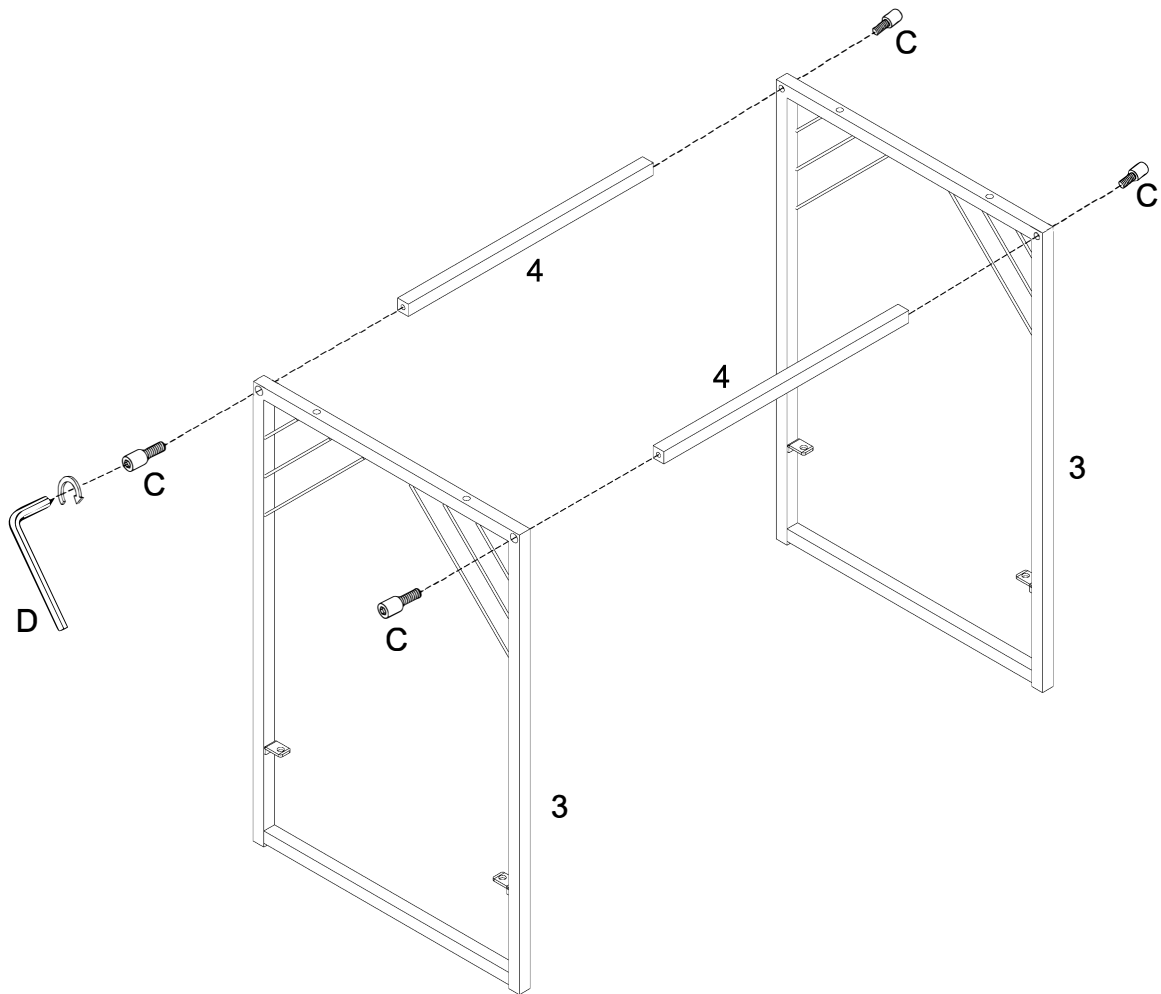

Using bolt (C) attach part (4) into part (3) with hex key (D) as per diagram.
Note : do not fully tighten all the bolt.

Step 2

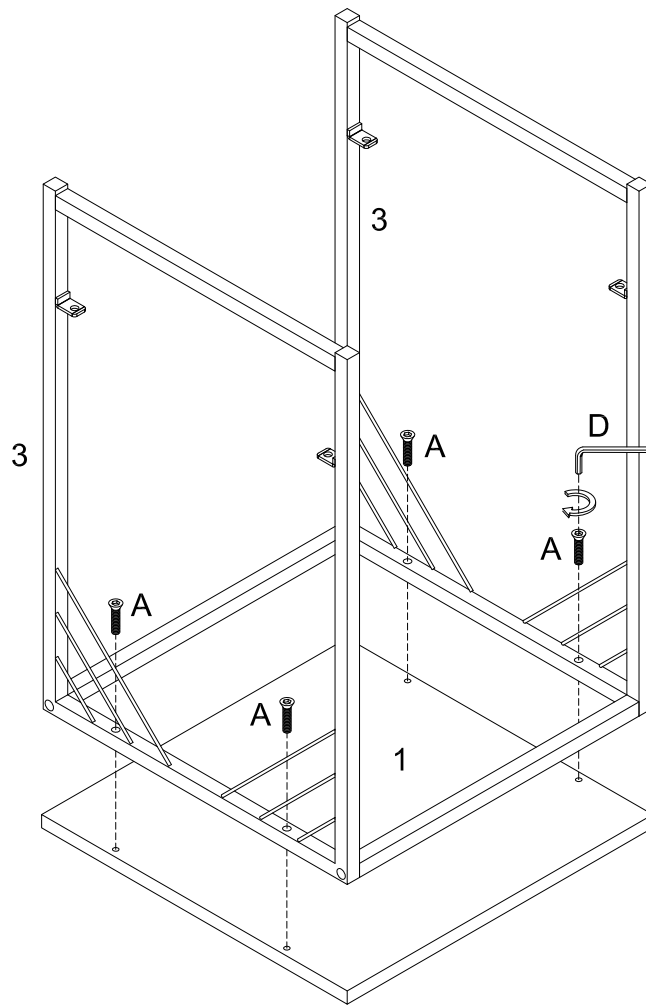

Using bolt (A) attach part (3) into part (1) with hex key (D) as per diagram.

Step 3

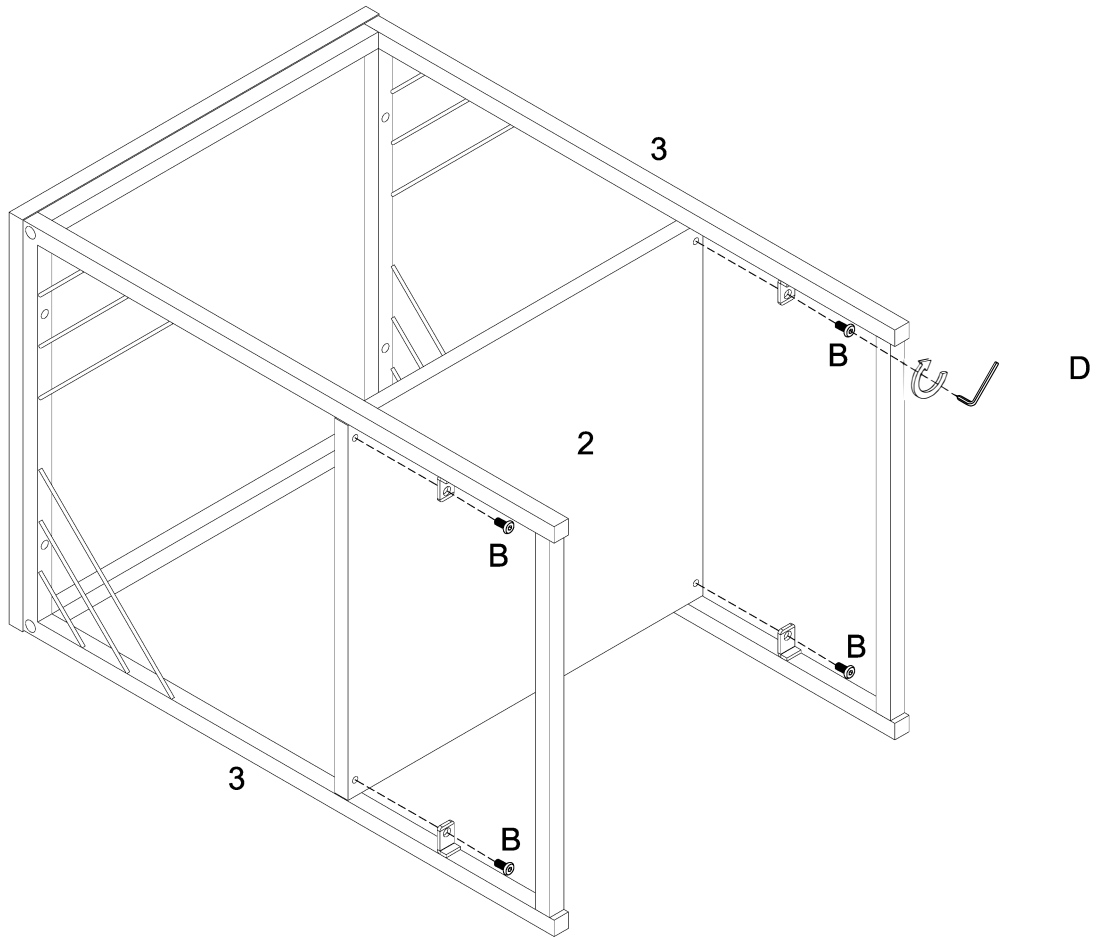

Using bolt (B) attach part (2) into part (3) with hex key (D) as per diagram. Then fully tighten all the bolts.

Step 4

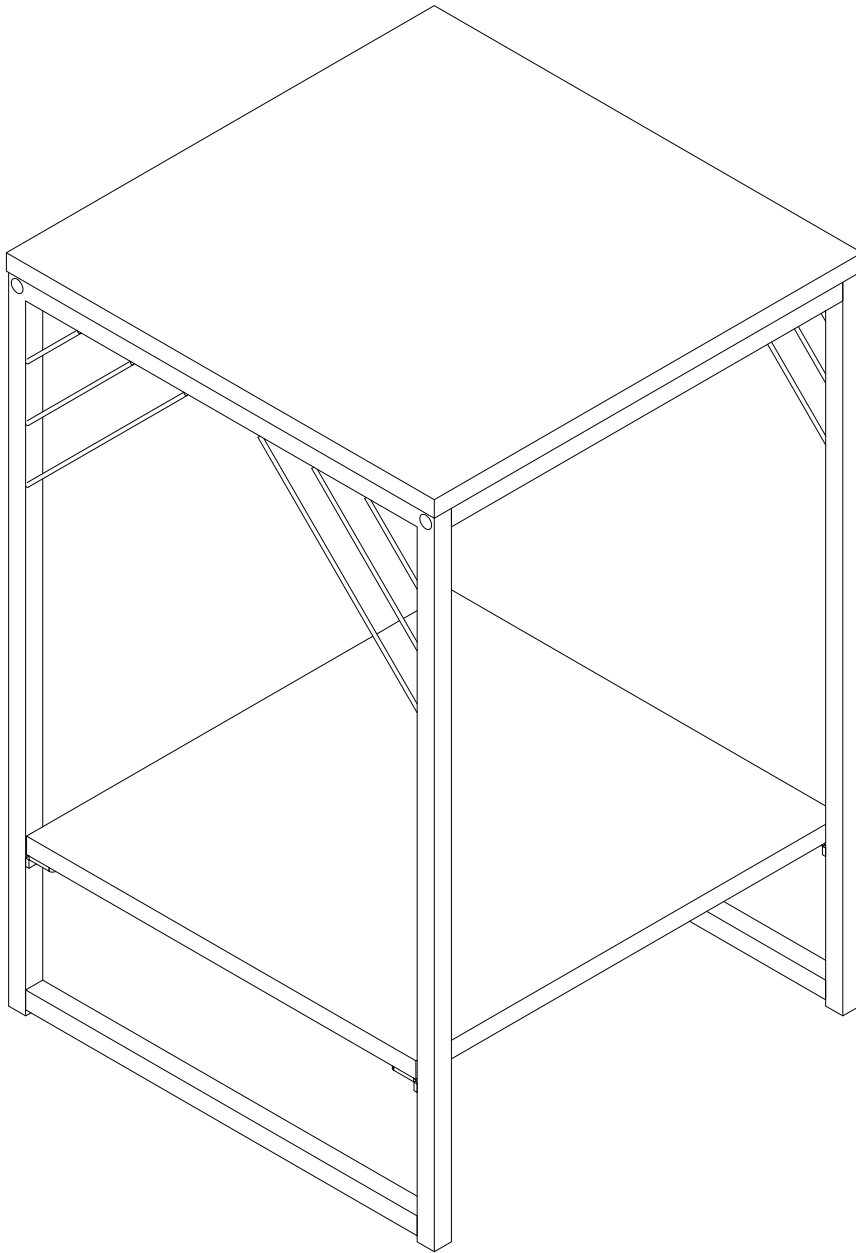

Final Assembly