

Installation & Assembly

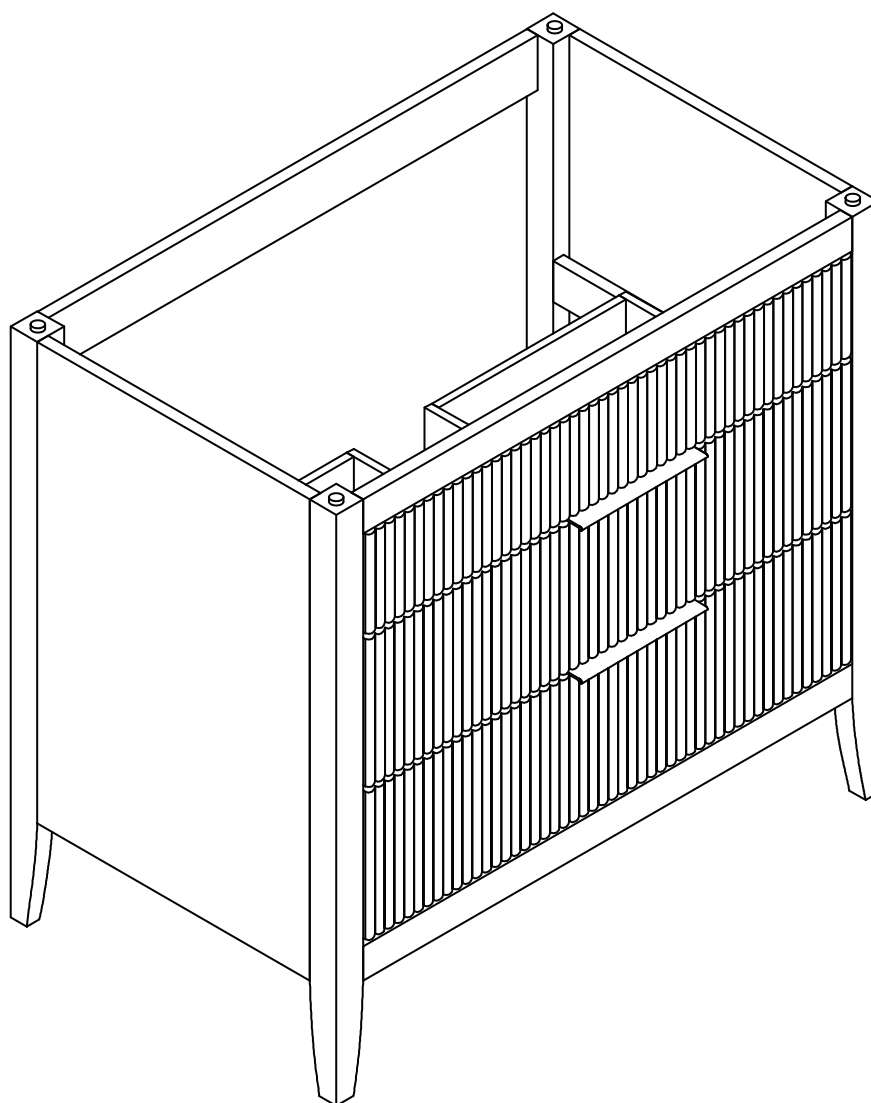

NOTICE

EN

Please keep these instructions for future reference.

Dear Customer

● Thank you for your purchase. When you receive the product, please make sure that all the parts are intact. If any parts are missing, please contact us promptly to request replacement parts.

● Then follow the entire installation instructions to install.

● Each part is crucial, so please be careful not to lose any. It is recommended to store parts with different lettered identifiers in separate boxes or bags to avoid confusion during installation.

A . The outer box is damaged

B . The product is damaged / bent / cracked while you open the box

C . The parts / accessories / assembly tools are missing

D . The instructions are not clear and can not be referred

E . The product has functional problems

F . Other aspects that you are not satisfied with

Please feel free to contact us for help, and provide the following information:

Platform/Shop name/Order id/Buyer's name/Receiver's address/Problem description/Problem pictures

Veillez conserver ces instructions pour consultation ultérieure.

Cher client

- Merci pour votre achat. Lorsque vous recevez le produit, veuillez vérifier que toutes les pièces sont présentes et en bon état. En cas de pièces manquantes, veuillez nous contacter sans tarder afin d'obtenir les pièces de remplacement.
- Ensuite, suivez attentivement toutes les instructions d'installation pour procéder au montage.
- Chaque pièce est essentielle ; veuillez donc faire attention à ne pas en perdre aucune. Nous vous recommandons de ranger les pièces portant des identifiants alphabétiques différents dans des boîtes ou sacs séparés afin d'éviter toute confusion lors de l'installation.

A . L'emballage extérieur est endommagé.

B . Le produit est endommagé, tordu ou fissuré au moment de l'ouverture de l'emballage.

C . Des pièces, accessoires ou outils de montage sont manquants.

D . Les instructions ne sont pas claires et ne peuvent être utilisées comme référence.

E . Le produit présente des problèmes de fonctionnement.

F . D'autres aspects du produit ou du service peuvent vous insatisfaire.

NBhéBitez paB à nouB contacter pour obtenir de lBaide et veuillez fournir leB informationB BuivanteB :

**Plateforme / Nom du magaBin/Numéro de commande/Nom de lBacheteur/
AdreBB du deBtinataire/DeBcription du problème/PhotoB du problème**

L'équipe de service clientèle pour les meubles d'intérieur

AVISO

ES

Por favor, guarde estas instrucciones para futuras referencias.

Estimado cliente

● Gracias por su compra. Cuando reciba el producto, asegúrese de que todas las piezas estén intactas. Si falta alguna pieza, contáctenos inmediatamente para solicitar las piezas de repuesto.

● A continuación, siga todas las instrucciones de instalación para proceder con el montaje.

● Cada pieza es crucial, por lo tanto, tenga cuidado de no perder ninguna. Se recomienda guardar las piezas con identificadores de letras diferentes en cajas o bolsas separadas para evitar confusiones durante la instalación.

A . El embalaje exterior está dañado.

B . El producto está dañado, doblado o agrietado al abrir la caja.

C . Faltan piezas, accesorios o herramientas de montaje.

D . Las instrucciones no son claras y no pueden consultarse adecuadamente.

E . El producto tiene problemas funcionales.

F . Otros aspectos con los que no está satisfecho.

No dude en contactarnos para obtener ayuda y proporcione la siguiente información:

**Plataforma / Nombre de la tienda/Número de pedido/Nombre del comprador/
Dirección del destinatario/Descripción del problema/Foto del problema**

Bitte bewahren Sie diese Anleitung für zukünftige Nachschlagesarbeiten auf. Sehr geehrter Kunde

- Vielen Dank für Ihren Kauf. Prüfen Sie bei Erhalt des Produkts bitte, ob alle Teile vollständig und unbeschädigt sind. Sollten Teile fehlen, kontaktieren Sie uns bitte umgehend, um Ersatzteile anzufordern.
- Befolgen Sie anschließend die gesamten Montageanweisungen, um die Installation durchzuführen.
- Jedes Teil ist wichtig, daher achten Sie bitte darauf, keines zu verlieren. Es wird empfohlen, Teile mit unterschiedlichen Buchstabenkennzeichnungen in separaten Boxen oder Tüten aufzubewahren, um Verwechslungen während der Montage zu vermeiden.

- A . Die äußere Verpackung ist beschädigt.
- B . Das Produkt ist beschädigt, verbogen oder rissig, als Sie die Verpackung öffnen.
- C . Teile, Zubehör oder Montagewerkzeuge fehlen.
- D . Die Anweisungen sind unklar und nicht als Referenz geeignet.
- E . Das Produkt weist Funktionsprobleme auf.
- F . Weitere Aspekte, mit denen Sie unzufrieden sind.

Zögern Sie nicht, uns bei Fragen oder Problemen zu kontaktieren. Bitte geben Sie dabei folgende Informationen an:

Plattform / Shop-Name/Bestellnummer/Käfername/Lieferadresse/ Problembeschreibung/Problembilder

Si prega di conservare queste istruzioni per consultazioni future.

Gentile cliente

- Grazie per l'acquisto. Quando riceve il prodotto, verifichi che tutti i componenti siano presenti e integri. In caso di componenti mancanti, la preghiamo di contattarci tempestivamente per richiedere i ricambi.
 - Quindi, seguire attentamente tutte le istruzioni di installazione per procedere al montaggio.
 - Ogni componente è essenziale; si prega quindi di fare attenzione a non perderne nessuno. Si consiglia di conservare i componenti con identificativi alfabetici diversi in contenitori o sacchetti separati per evitare confusione durante l'installazione.
- A . L'imballaggio esterno è danneggiato.
- B . Il prodotto è danneggiato, piegato o crepato all'apertura della confezione.
- C . Alcuni componenti, accessori o utensili di assemblaggio sono mancanti.
- D . Le istruzioni non sono chiare e non possono essere utilizzate come riferimento.
- E . Il prodotto presenta problemi funzionali.
- F . Altri aspetti con cui non è soddisfatto.



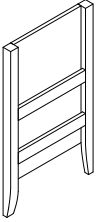
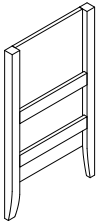
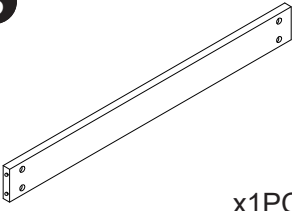
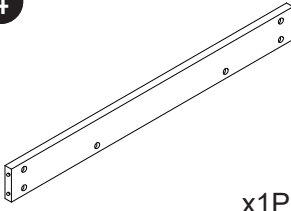
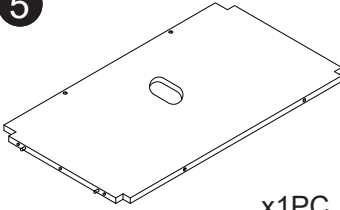
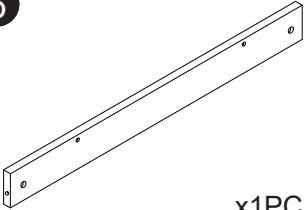
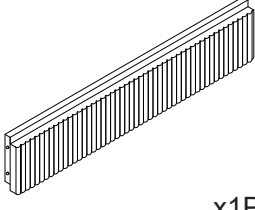
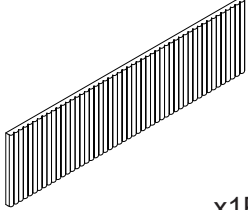
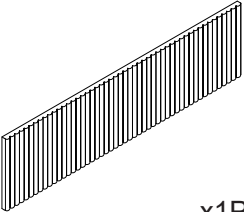
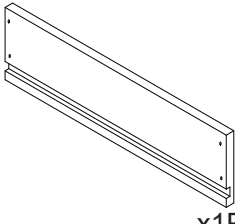
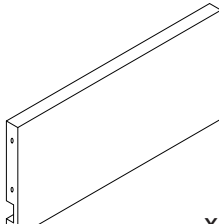
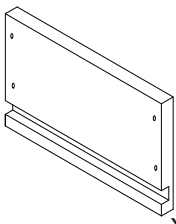
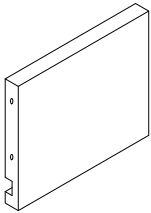
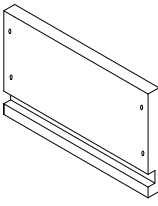
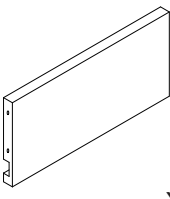
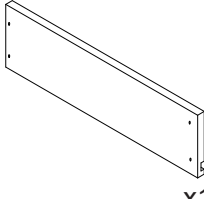
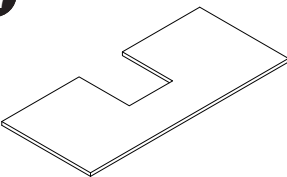
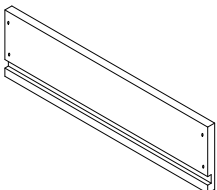
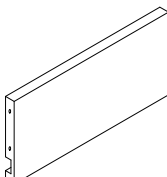
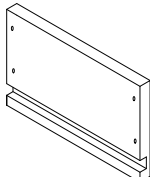
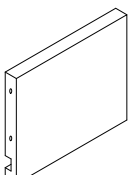
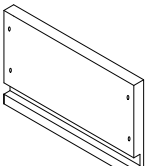
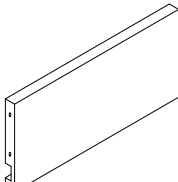
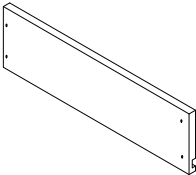
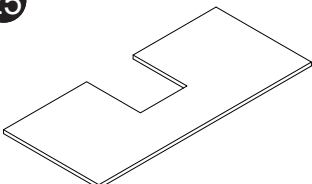
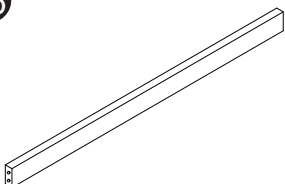

Non esiti a contattarci per richiedere assistenza e fornisca le seguenti informazioni:

**Piattaforma / Nome del negozio/Numero dsordine/Nome dellsacquirente/
Indirizzo del destinatario/Descrizione del problema/Foto del problema**

PART LIST

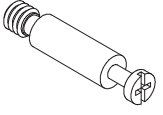
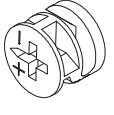
<p>1</p>  <p>x1PC</p>	<p>2</p>  <p>x1PC</p>	<p>3</p>  <p>x1PC</p>	<p>4</p>  <p>x1PC</p>
<p>5</p>  <p>x1PC</p>	<p>6</p>  <p>x1PC</p>	<p>7</p>  <p>x1PC</p>	<p>8</p>  <p>x1PC</p>
<p>9</p>  <p>x1PC</p>	<p>10</p>  <p>x1PC</p>	<p>11</p>  <p>x1PC</p>	<p>12</p>  <p>x1PC</p>
<p>13</p>  <p>x1PC</p>	<p>14</p>  <p>x1PC</p>	<p>15</p>  <p>x1PC</p>	<p>16</p>  <p>x1PC</p>
<p>17</p>  <p>x1PC</p>	<p>18</p>  <p>x1PC</p>	<p>19</p>  <p>x1PC</p>	<p>20</p>  <p>x1PC</p>
<p>21</p>  <p>x1PC</p>	<p>22</p>  <p>x1PC</p>	<p>23</p>  <p>x1PC</p>	<p>24</p>  <p>x1PC</p>
<p>25</p>  <p>x1PC</p>	<p>26</p>  <p>x1PC</p>		

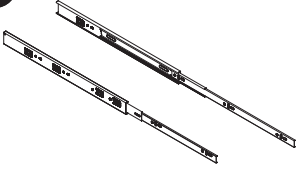
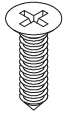
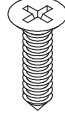
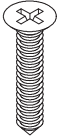
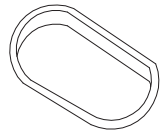
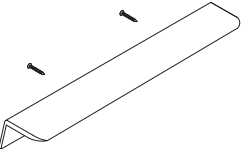
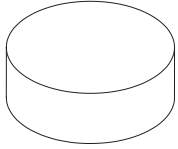
PART LIST

<p>A</p>  <p>x25PCS</p>	<p>B</p>  <p>x25PCS</p>	<p>C</p>  <p>φ8 X 40MM x6PCS</p>	<p>D</p>  <p>x2PCS</p>
<p>E</p>  <p>M4 X 12MM x12PCS</p>	<p>F</p>  <p>M4 X 16MM x12PCS</p>	<p>G</p>  <p>M4 X 25MM x32PCS</p>	<p>H</p>  <p>x1PC</p>
<p>I</p>  <p>x2PCS</p>	<p>J</p>  <p>x4PCS</p>	<p>K</p>  <p>x53PCS</p>	

WARNING

EN

Please do not tighten all the screws before the assembling is done.

DE

Bitte ziehen Sie alle Schrauben erst fest, wenn die Montage abgeschlossen ist.

FR

Veuillez ne pas serrer toutes les vis avant que l'assemblage ne soit terminé.

IT

Si prega di non serrare tutte le viti prima che il montaggio sia completato.

ES

Por favor, no apriete todos los tornillos antes de que el ensamblaje esté terminado.

PART LIST

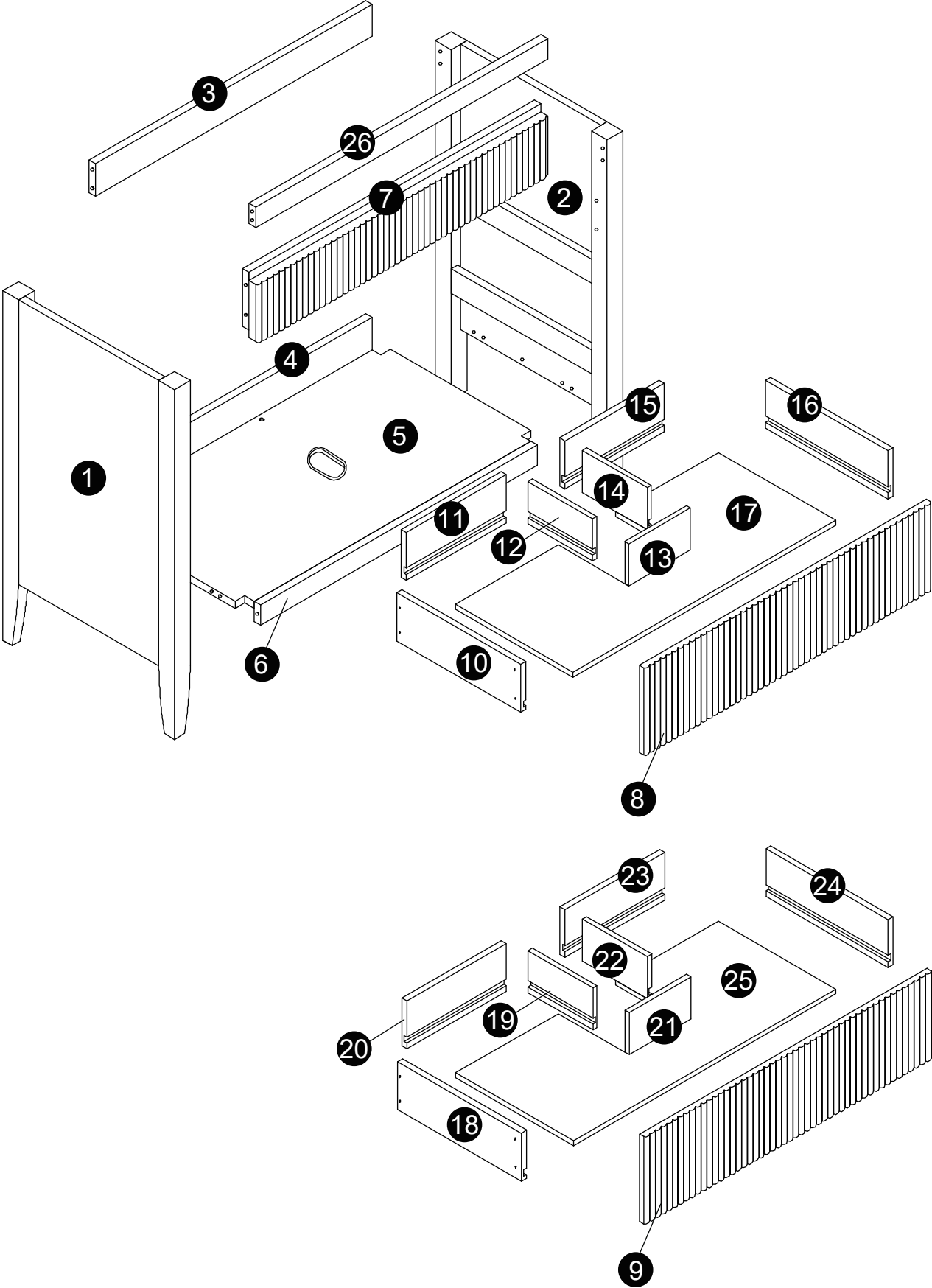

STEP

01

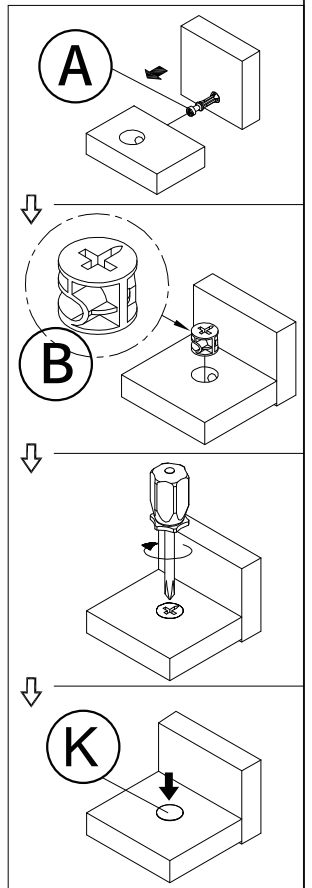
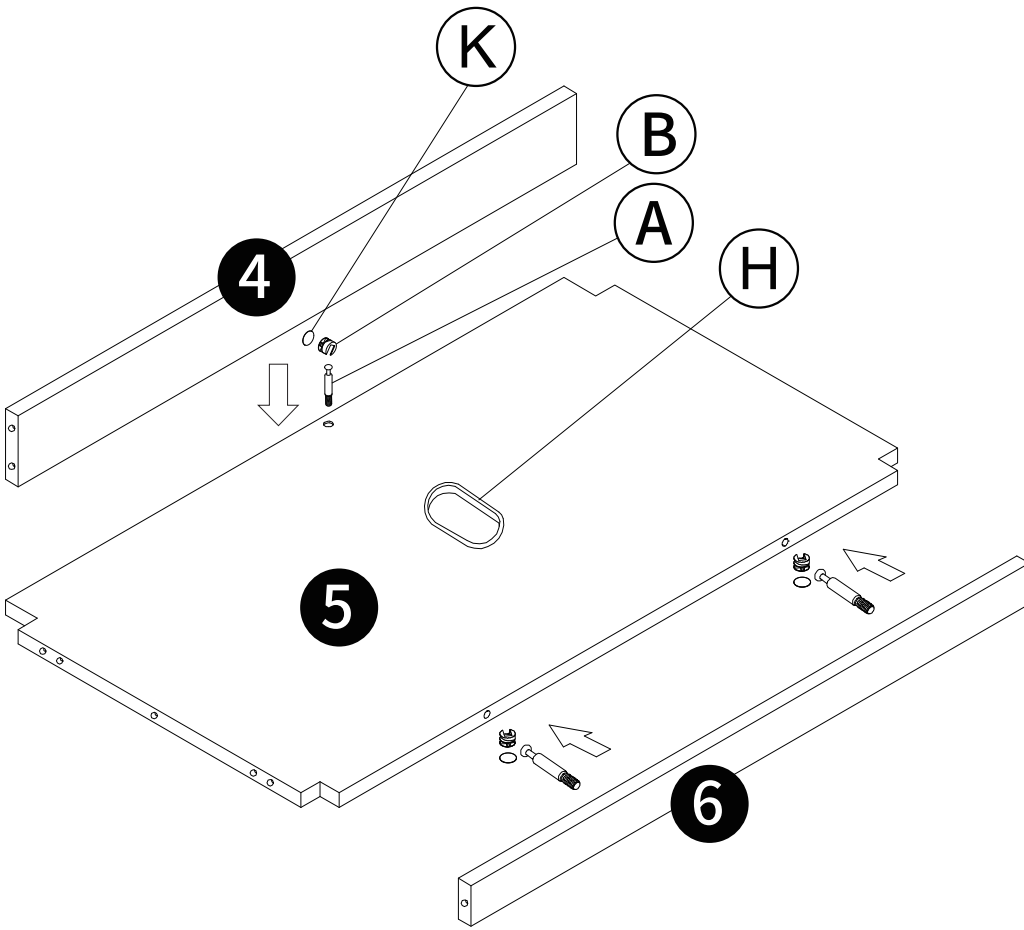
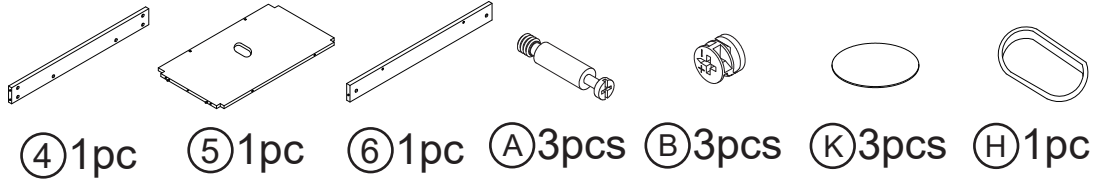

STEP

02

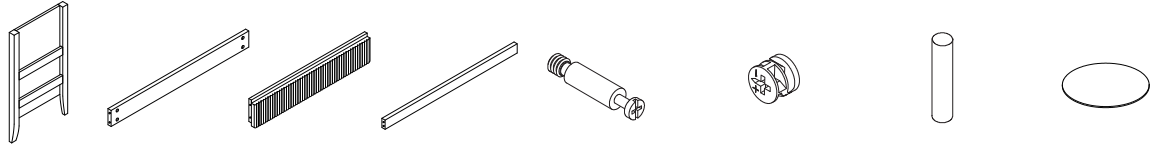

②1pc ③1pc ⑦1pc ②⑥1pc ①11pcs ①11pcs ③3pcs ①11pcs

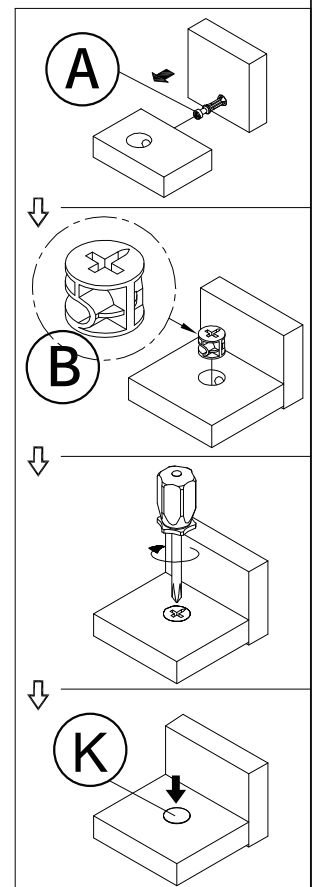
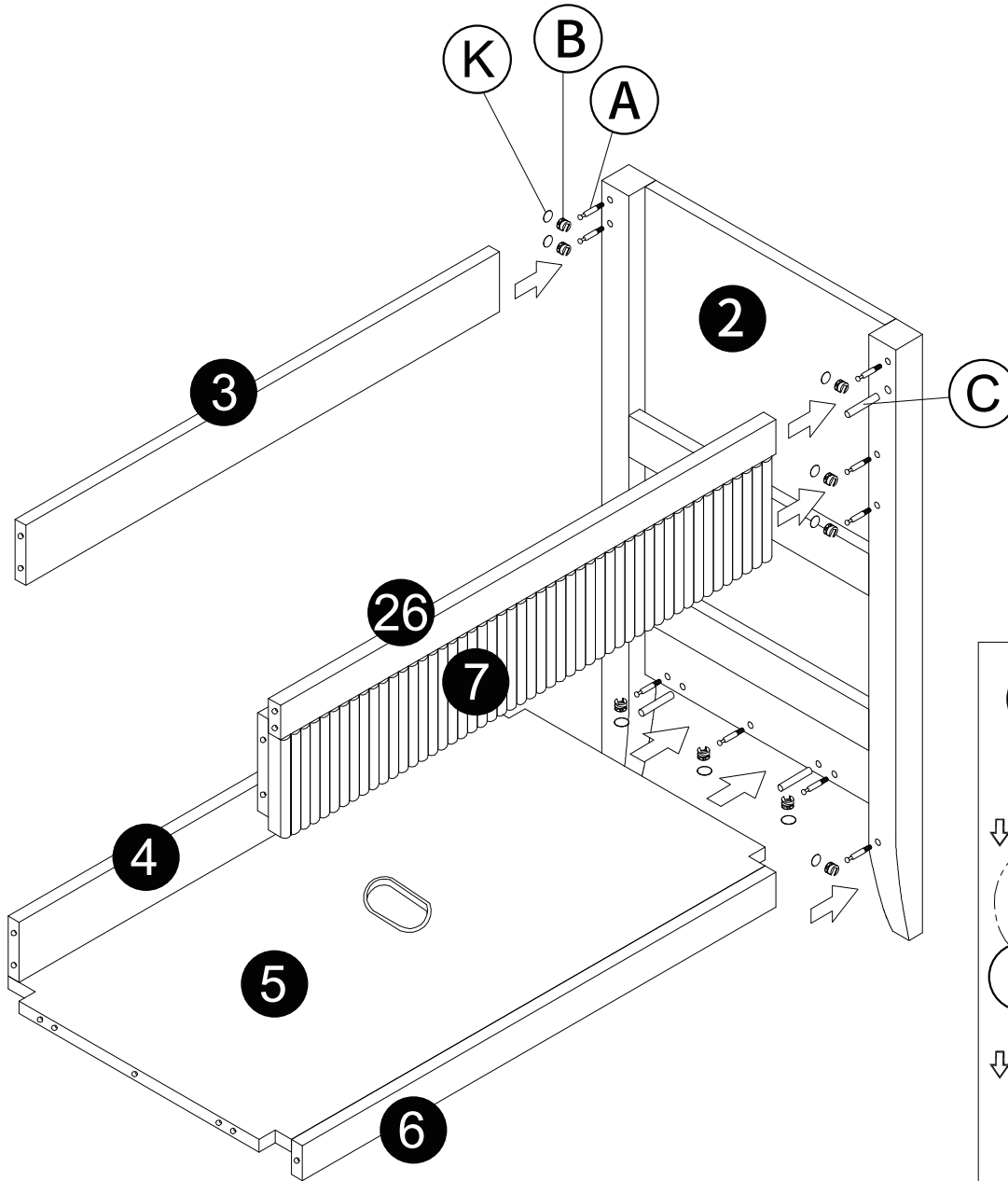

STEP

03

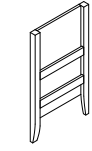

① 1pc

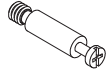

Ⓐ 11pcs



Ⓑ 11pcs



Ⓒ 3pcs

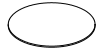

Ⓚ 11pcs

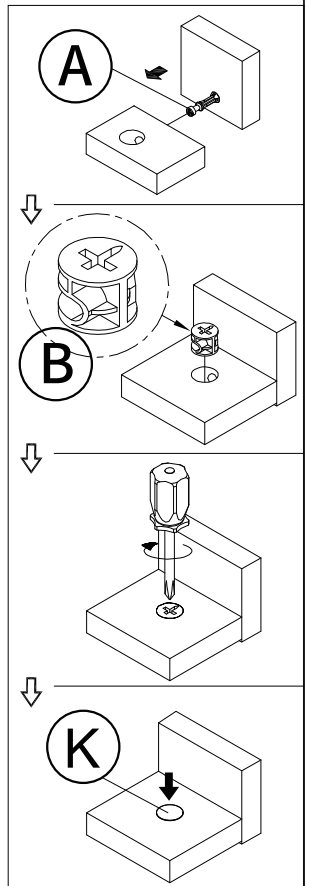
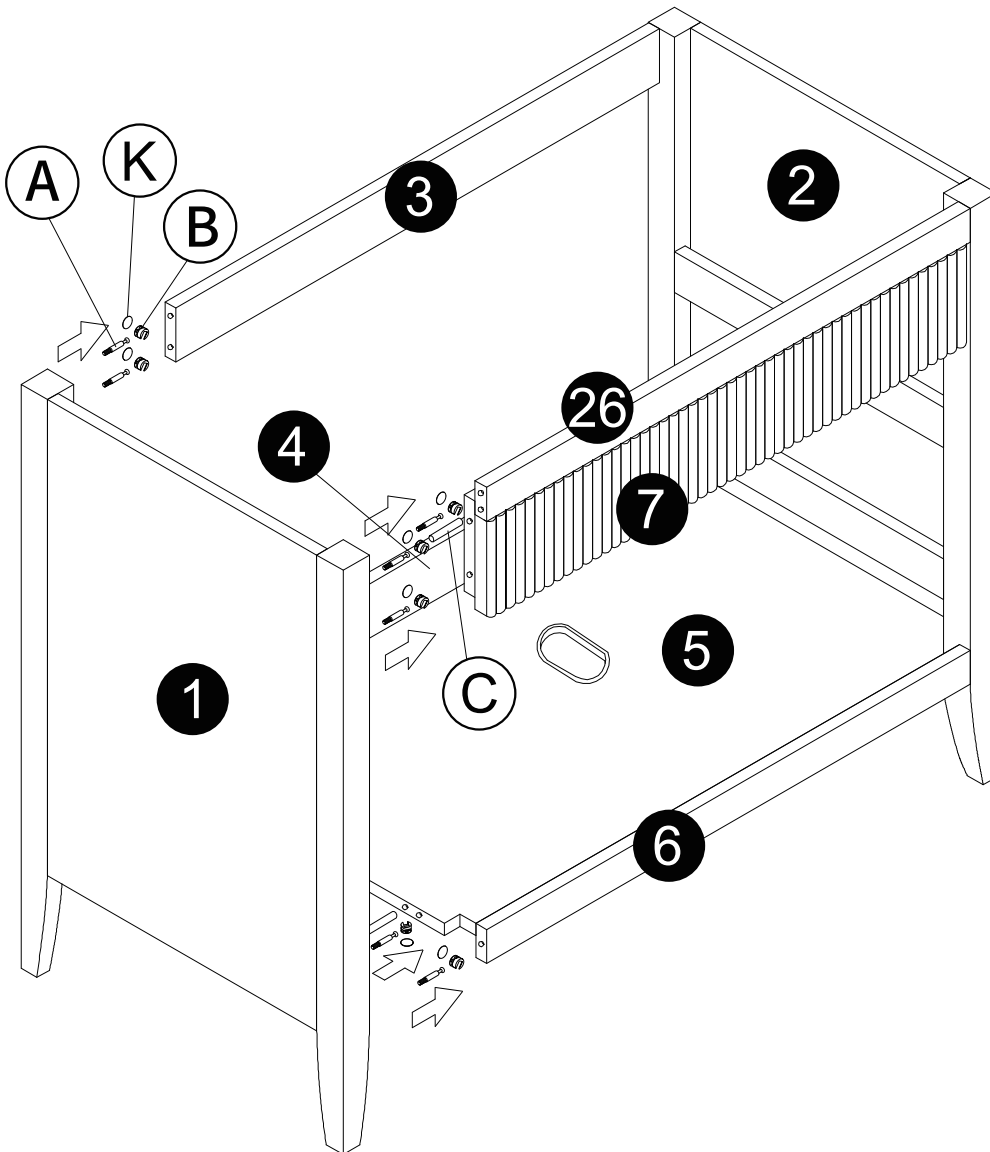

STEP

04



ⓓ 2 pcs



ⓕ 12 pcs

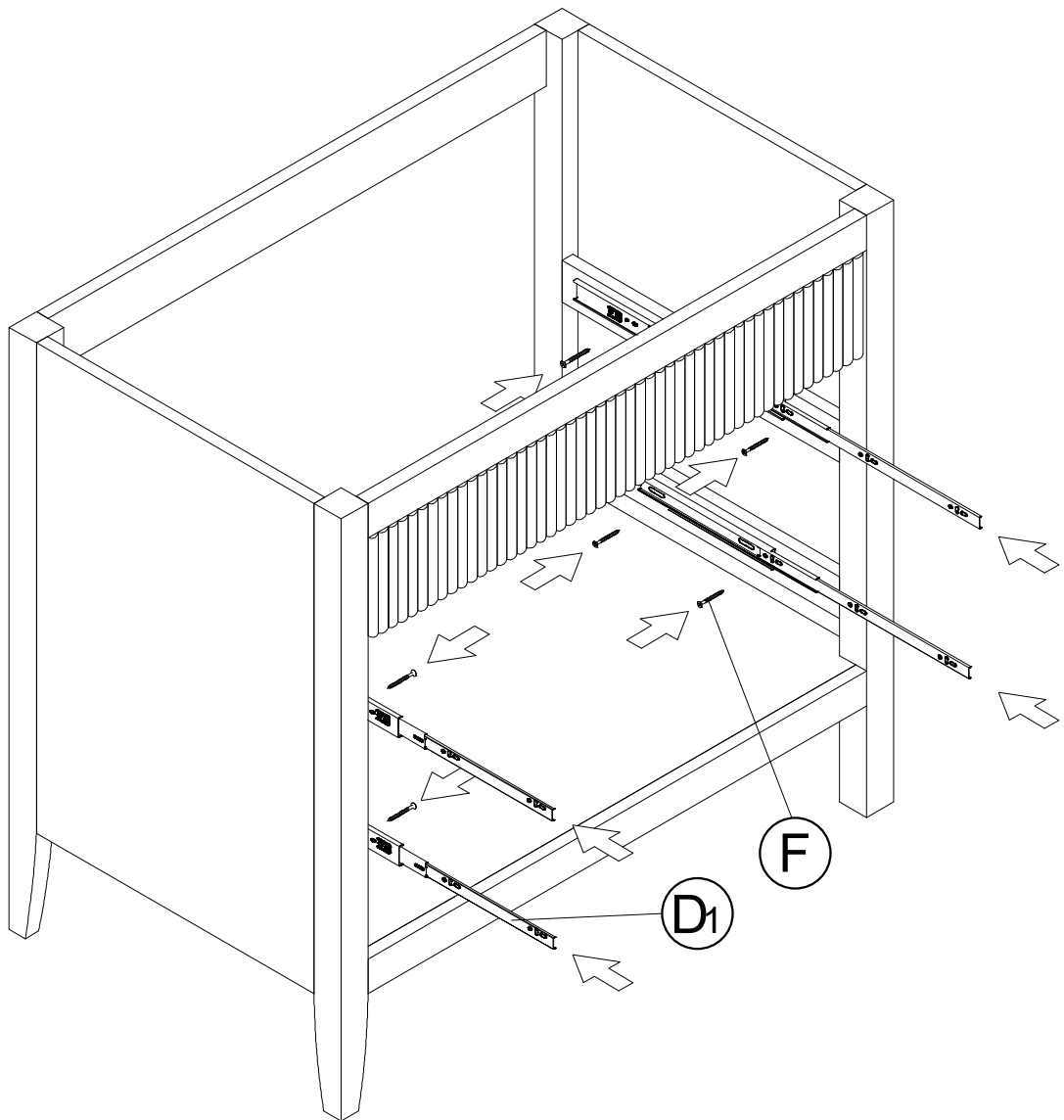
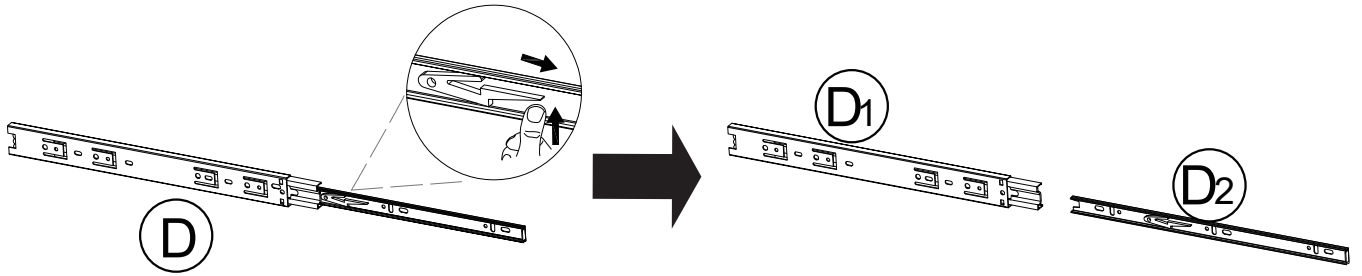

STEP

05

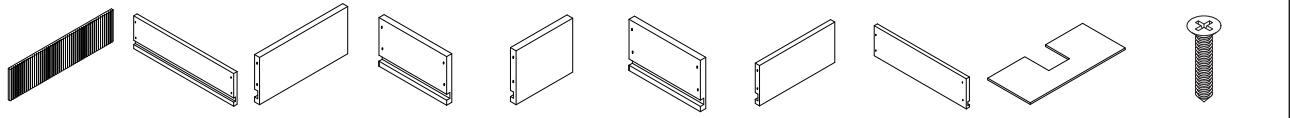
- 
- ⑧ 1pc ⑩ 1pc ⑪ 1pc ⑫ 1pc ⑬ 1pc ⑭ 1pc ⑮ 1pc ⑯ 1pc ⑰ 1pc ⑱ 16pcs

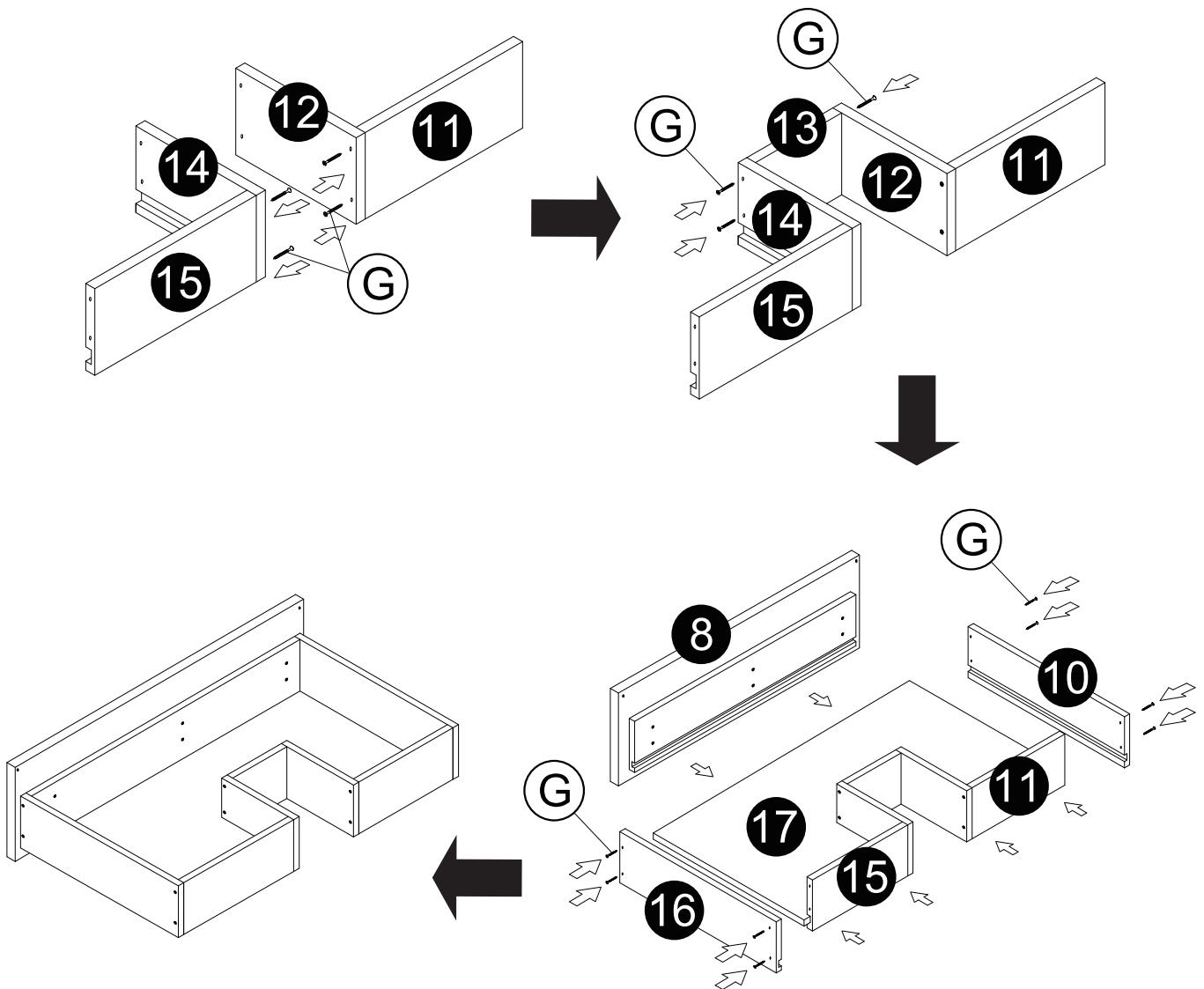

STEP

06

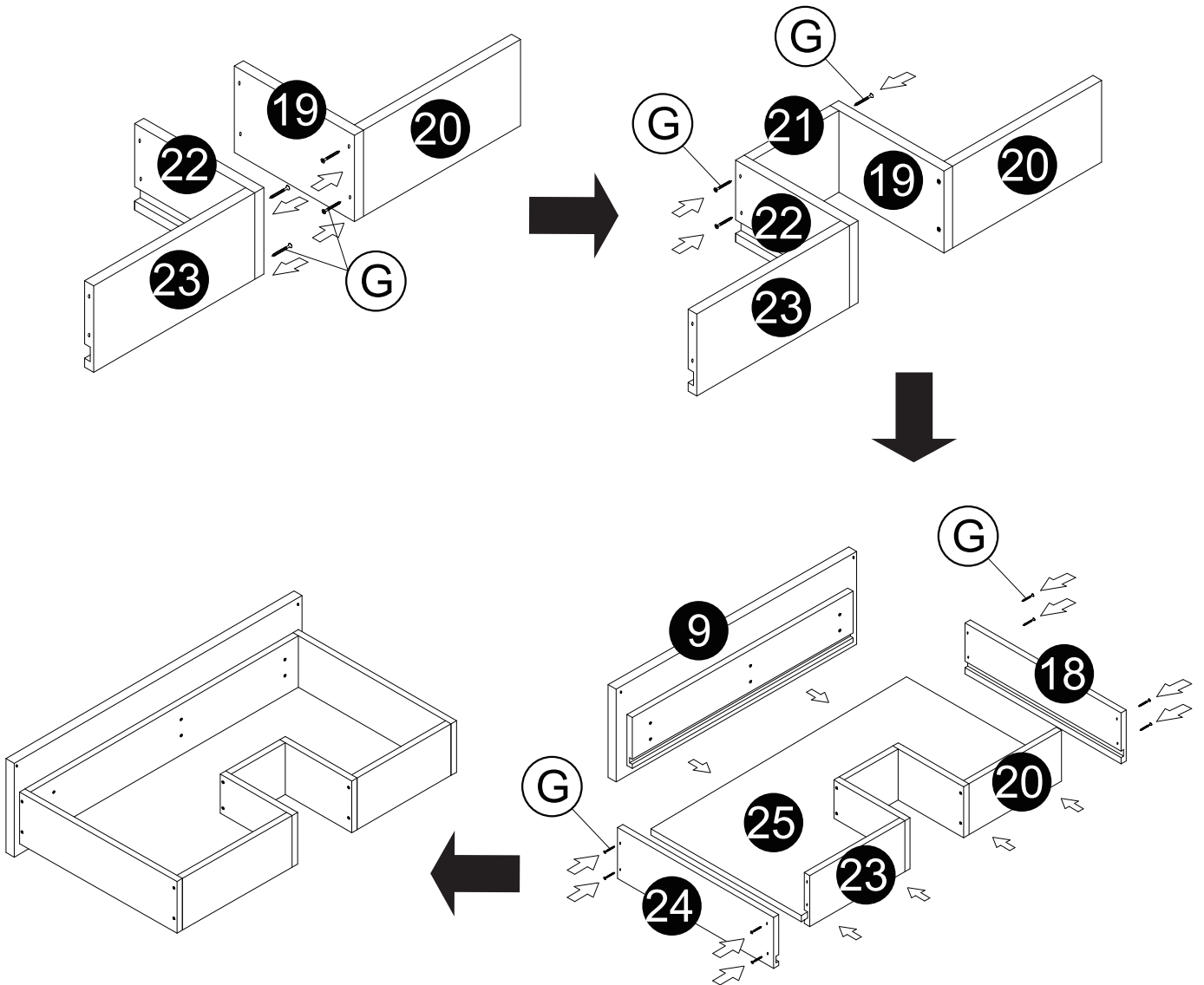
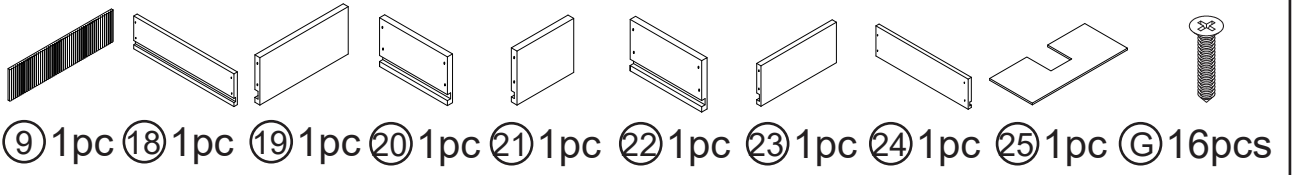

STEP

07



ⓔ 6pcs

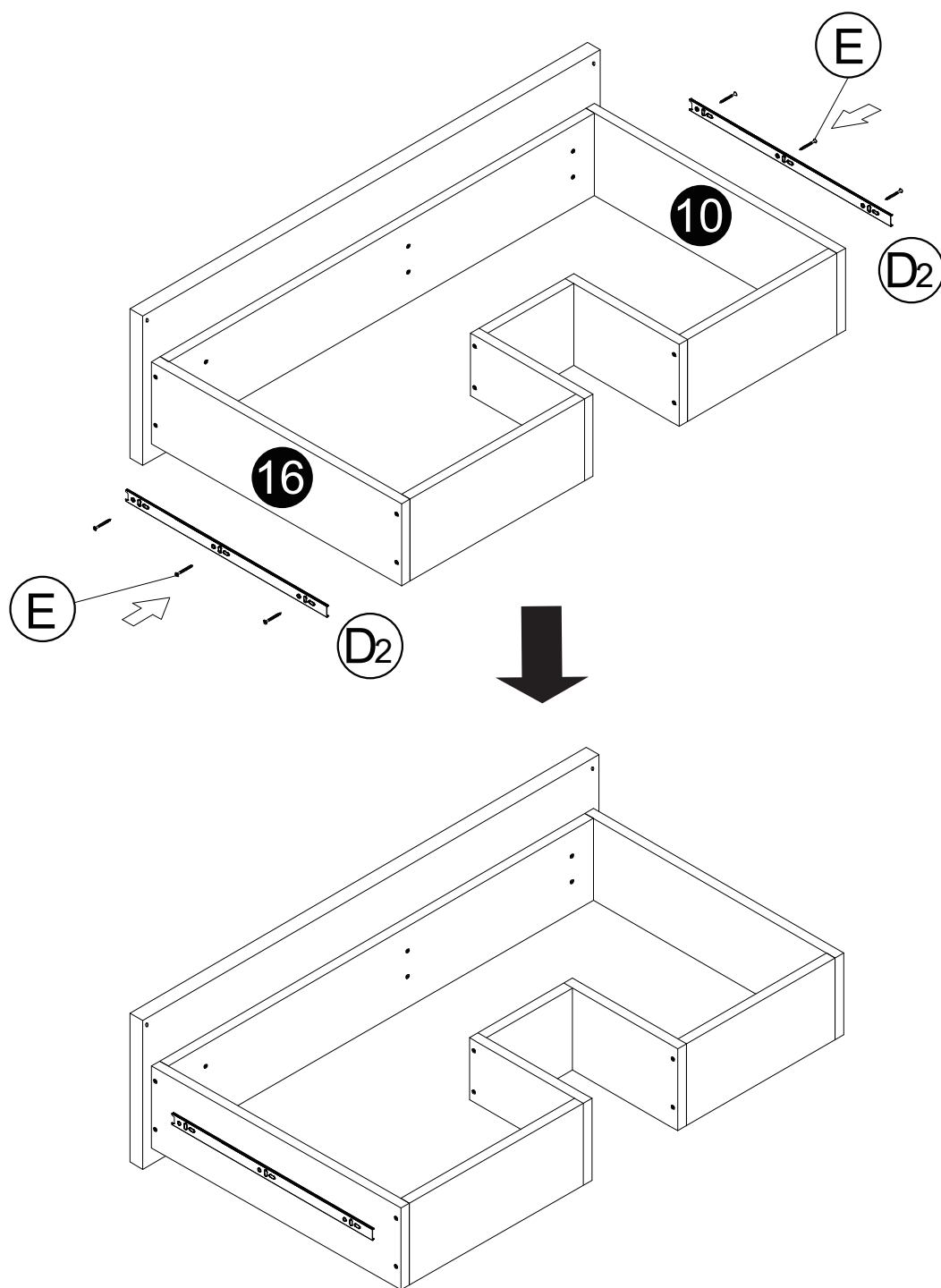

STEP

08

E 6pcs

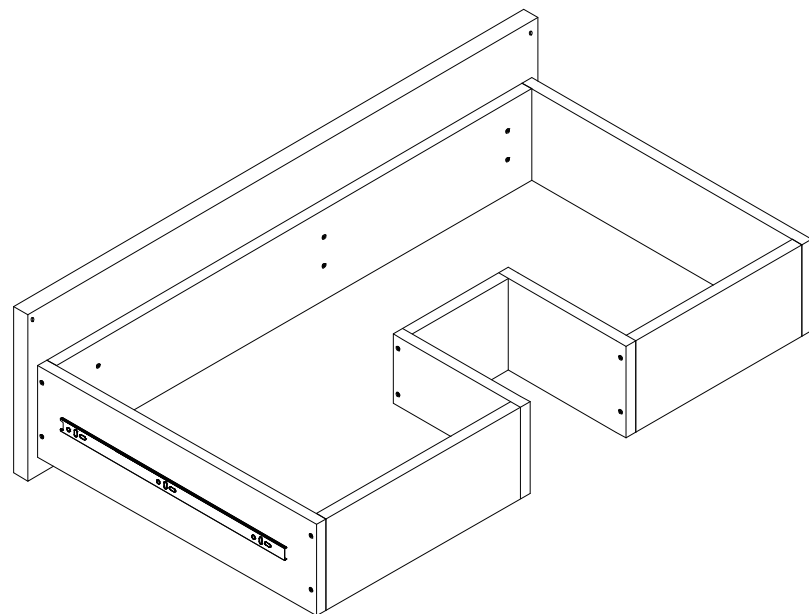
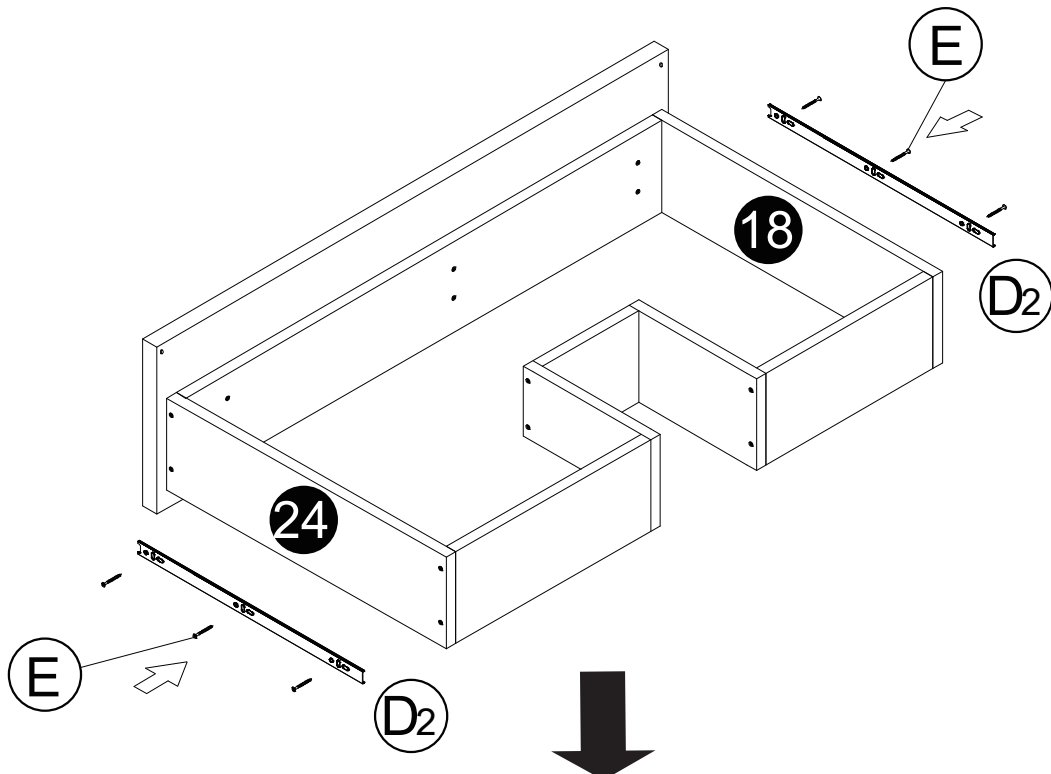

STEP

09

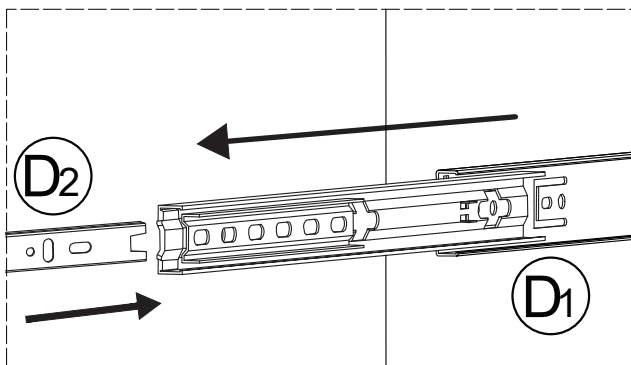
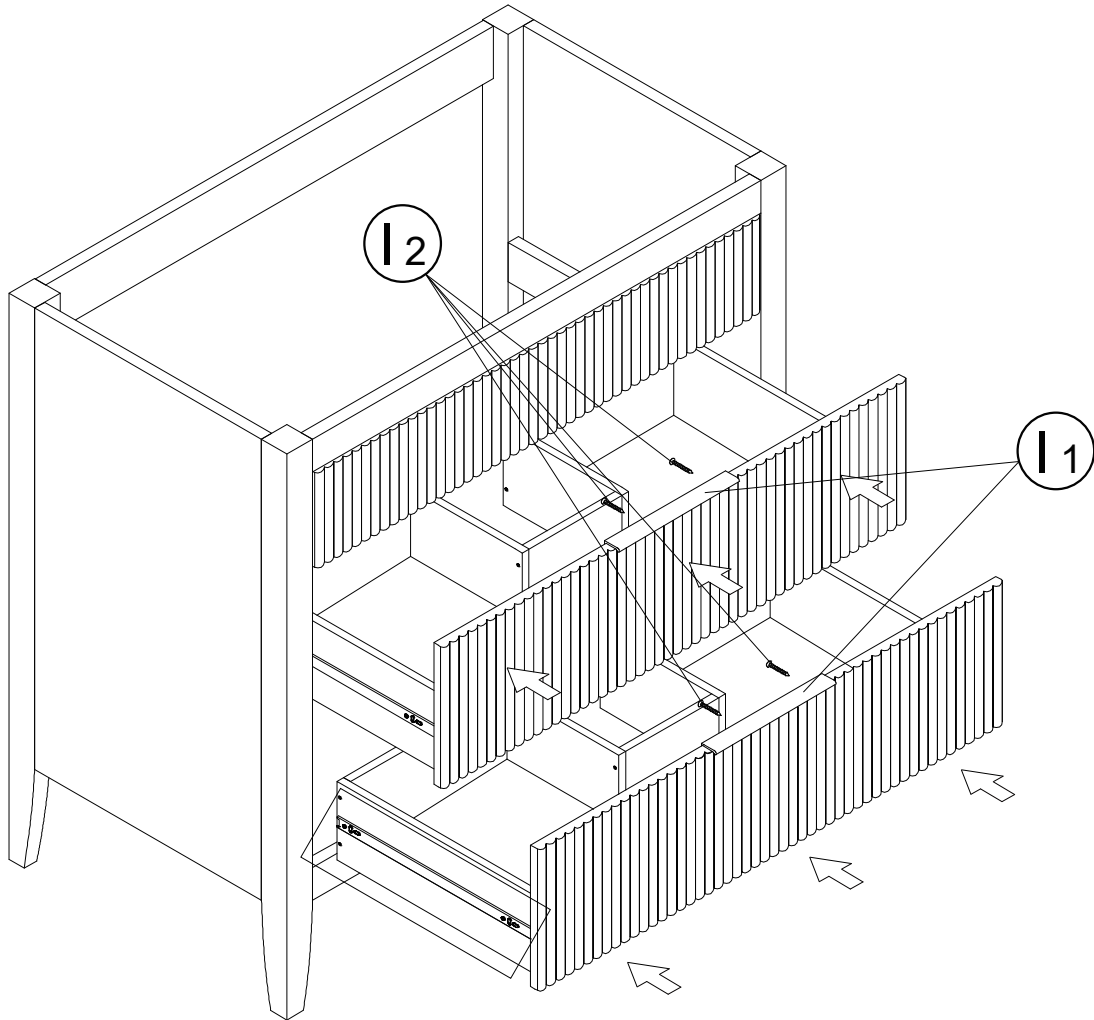
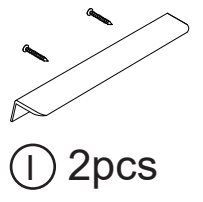

STEP

10

ⓐ 4pcs

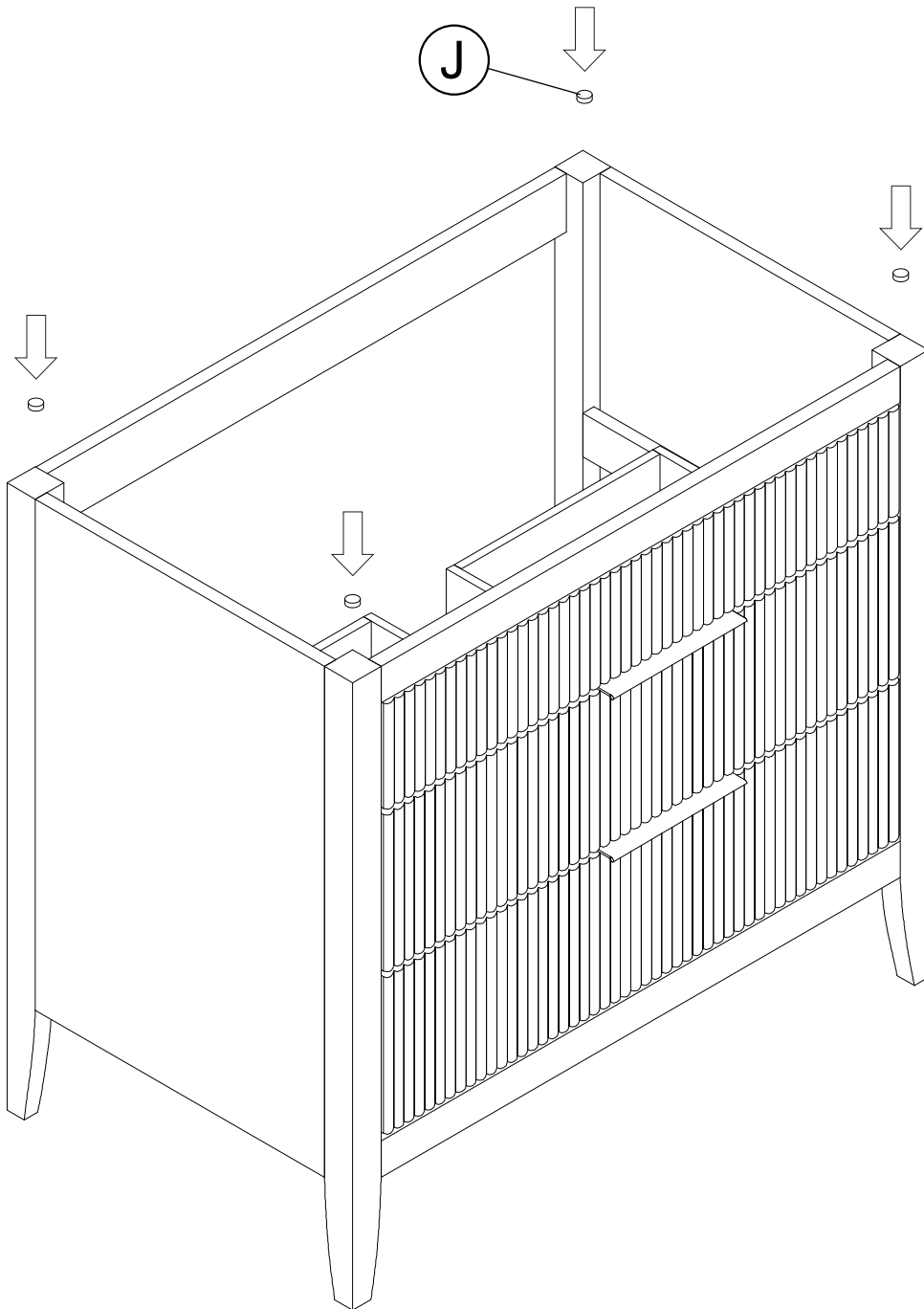

EN

AFTER-SALE SERVICE

If you have any suggestions for our products or notice any quality issues, please contact us first. Our after-sales team will respond within 24 hours and will do everything possible to provide you with a satisfactory solution.

Guaranteed Customer Service

Your shopping experience is very important to us!

Feel unsatisfied? **Contact us!**

Have any questions? **Contact us!**

Wanna Share how wonderful our smart products make your home?

Share your pictures with us.

Any suggestions? **Contact us!**

We will check and give feedback.

FR

SERVICE APRÈS-VENTE

Si vous avez des suggestions concernant nos produits ou si vous remarquez un quelconque problème de qualité, veuillez nous contacter en premier lieu. Notre service après-vente vous répondra dans les 24 heures et fera tout son possible pour vous proposer une solution satisfaisante.

Service client garanti

Votre expérience d'achat est très importante pour nous !

Pas satisfait ? **Contactez-nous !**

Des questions ? **Contactez-nous !**

Souhaitez-vous partager à quel point nos produits Siait rendent votre maison plus belle ?

Partagez vos photos avec nous.

Des suggestions ? **Contactez-nous !**

Nous examinerons la situation et vous répondrons rapidement.

ES

SERVICIO POSTVENTA

Si tiene alguna sugerencia sobre nuestros productos o detecta algún problema de calidad, no dude en contactarnos primero. Nuestro equipo de posventa responderá dentro de las 24 horas y hará todo lo posible por ofrecerle una solución satisfactoria.

Servicio al cliente garantizado

¿Su experiencia de compra es muy importante para nosotros!

¿No está satisfecho? ¡**Contáctenos!**

¿Tiene alguna pregunta? ¡**Contáctenos!**

¿Quiere compartir lo maravilloso que hacen nuestros productos Siat en su hogar?

Comparta sus fotos con nosotros.

¿Alguna sugerencia? ¡**Contáctenos!**

Verificaremos la información y le responderemos.

KUNDENDIENST

Falls Sie Verbesserungsvorschläge zu unseren Produkten haben oder Qualitätsprobleme bemerken, wenden Sie sich bitte zunächst an uns. Unser Kundendienst wird innerhalb von 24 Stunden antworten und alles tun, um Ihnen eine zufriedenstellende Lösung anzubieten.

Garantierte Kundenservice-Leistung

Ihre Einkaufserfahrung ist uns sehr wichtig!

Unzufrieden? **Kontaktieren Sie uns!**

Fragen? **Kontaktieren Sie uns!**

Möchten Sie erzählen, wie wunderbar unsere Siat-Produkte Ihr Zuhause verändern?

Teilen Sie Ihre Fotos mit uns.

Haben Sie Vorschläge? **Kontaktieren Sie uns!**

Wir werden dies prüfen und Ihnen umgehend Rückmeldung geben.

IT

ASSISTENZA POST- VENDITA

Se ha suggerimenti riguardo ai nostri prodotti o dovesse notare problemi di qualità, la preghiamo di contattarci in primo luogo. Il nostro team post-vendita risponderà entro 24 ore e farà il possibile per fornirle una soluzione soddisfacente.

Kundenservice mit Garantie

La Sua esperienza di acquisto è molto importante per noi!

Non soddisfatto? **Contattateci!**

Domande? **Contattateci!**

Vuole condividere quanto meravigliosamente i nostri prodotti

Siait rendono accogliente la sua casa?

Condivida le sue foto con noi.

Ha dei suggerimenti? **Contattateci!**

Controlleremo la situazione e le forniremo un riscontro.