

STEP 5

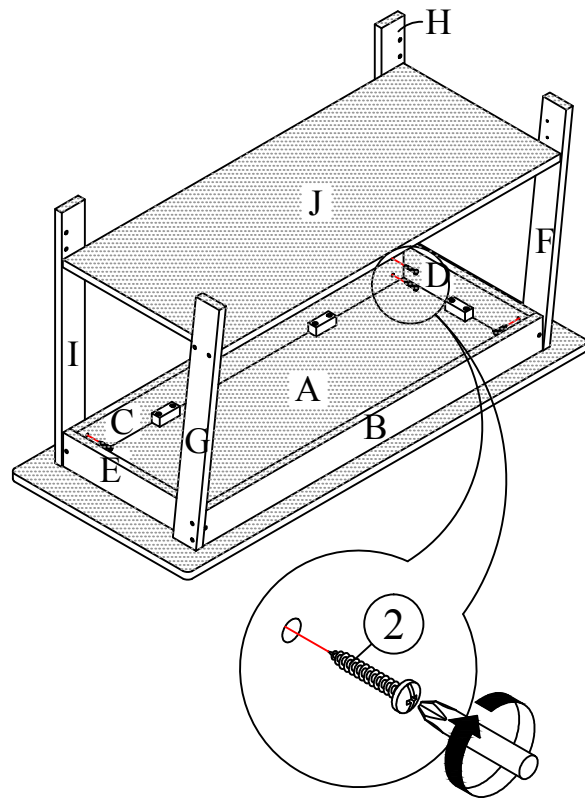

STEP 6

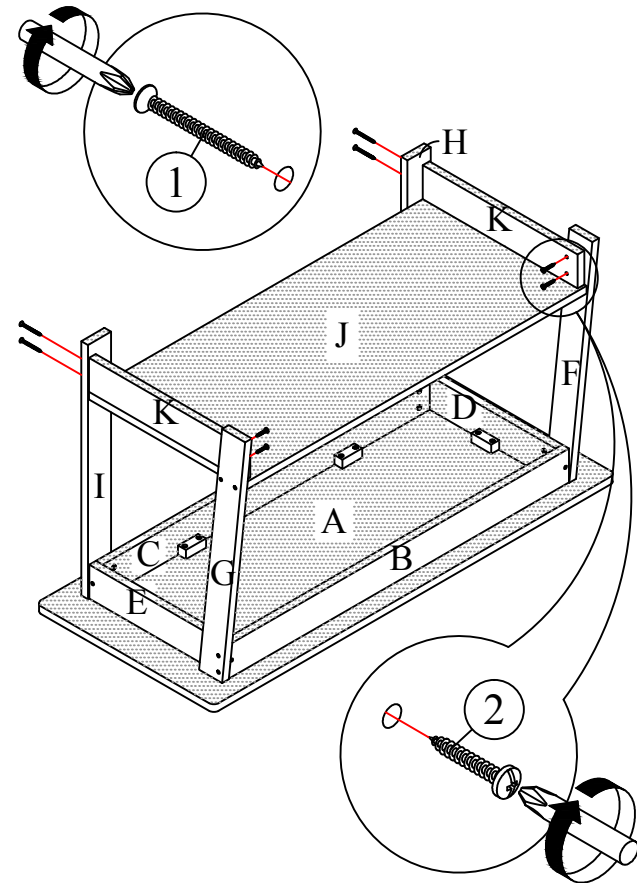

STEP 7

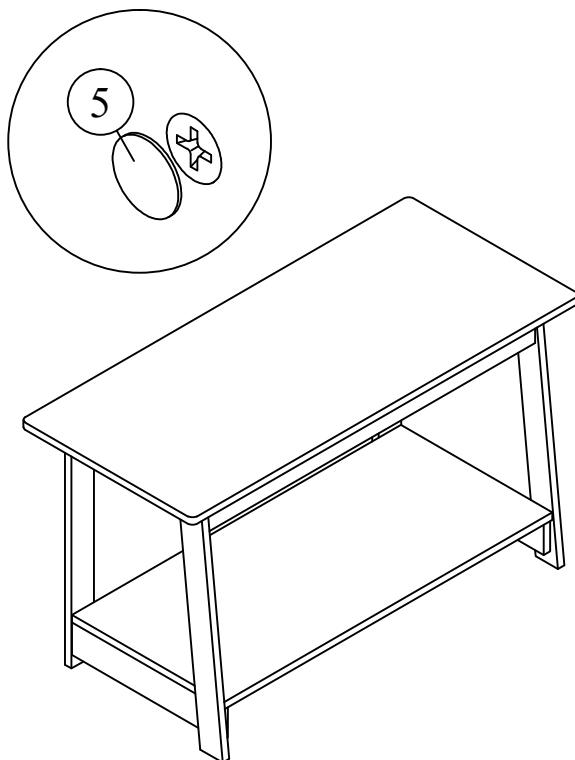

Recommended Maximum Weight

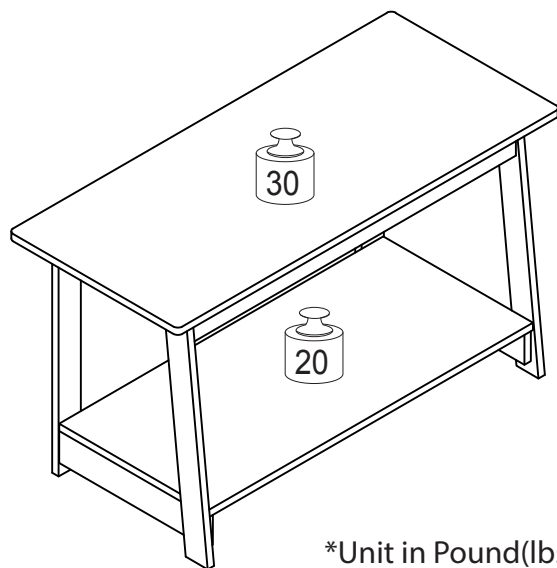

*Unit in Pound(lbs)

WARNING:

- >This unit has been designed to support the maximum loads shown. Exceeding these load limits could cause sagging, instability, product collapse, and/or serious injury.
- >DO NOT allow children to climb on unit.
- >Put heavier items on lower shelves.

Assembly Instruction

00:30

Approx. 30 minutes





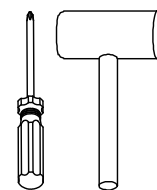

Recomm. 2 Person

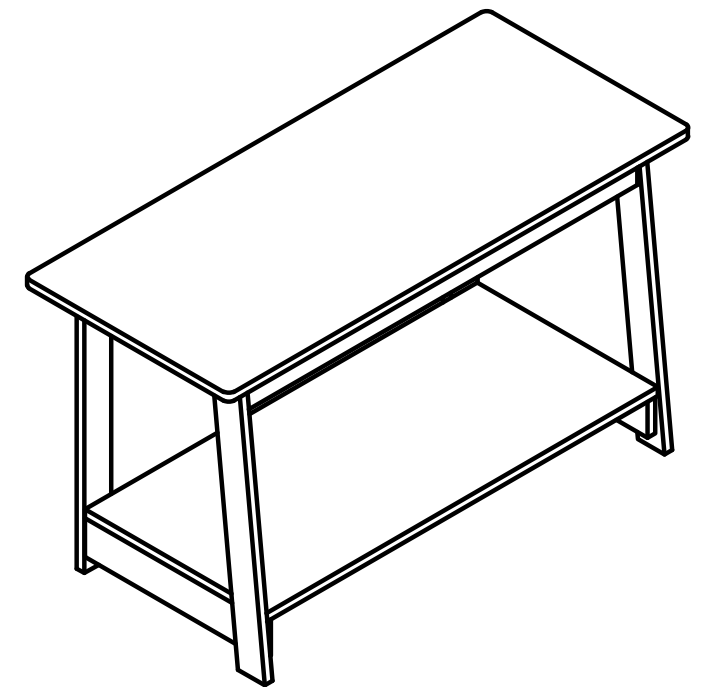

Tool Required

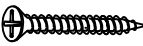

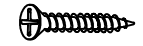
NO	PARTS LIST	QTY
A	TOP PANEL	1pc
B	FRONT SUPPORT PANEL	1pc
C	BACK SUPPORT PANEL	1pc
D	LEFT SIDE SUPPORT PANEL	1pc
E	RIGHT SIDE SUPPORT PANEL	1pc
F	FRONT LEFT LEG PANEL	1pc
G	FRONT RIGHT LEG PANEL	1pc
H	BACK LEFT LEG PANEL	1pc
I	BACK RIGHT LEG PANEL	1pc
J	BOTTOM PANEL	1pc
K	LEG SUPPORT PANEL	2pcs

NO	HARDWARE LIST	QTY
1	LONG SCREW 	24pcs
2	PH TAPPING SCREW 	12pcs
3	BRACKET 	6pcs
4	MIDDLE SCREW 	12pcs
5	STICKER 	14pcs

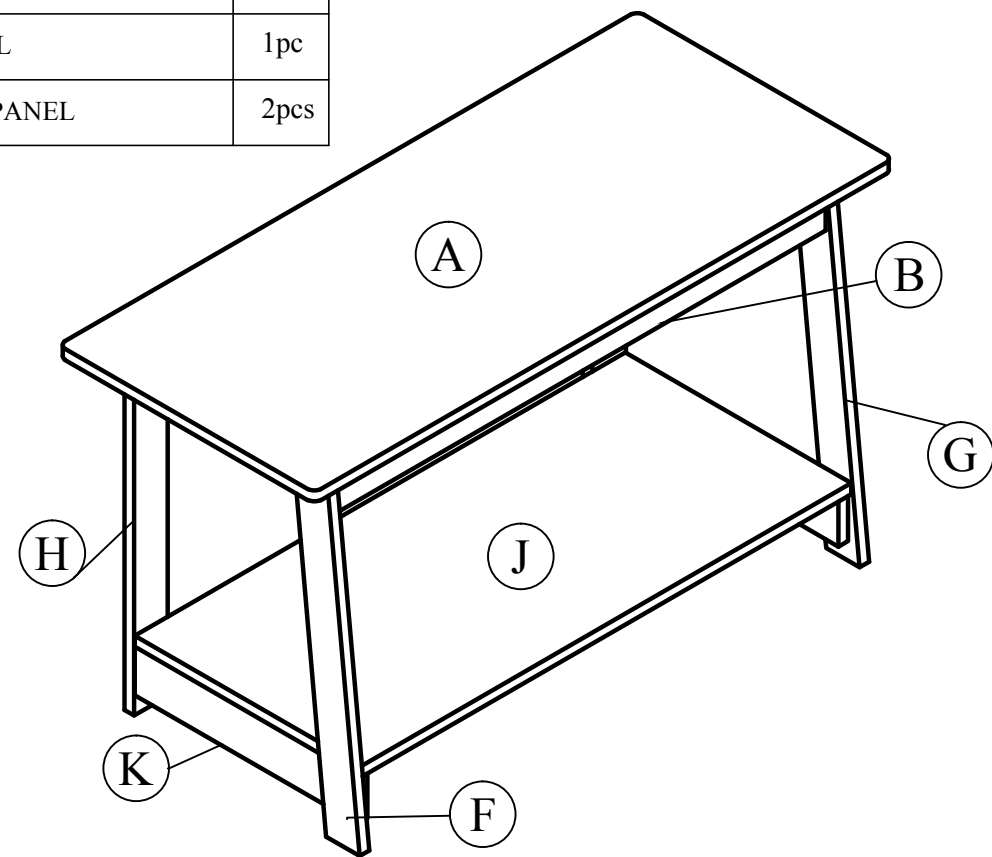

USEFUL HINTS BEFORE YOU START:

1. Read each step carefully before starting.
2. It is important that each step is performed in correct order to avoid difficulties.
3. Identify, sort and count the parts before assembly.
4. Assemble your furniture on packaging cardboard to prevent scratch or damage.
5. Clean the product with mild cleanser using soft damp cloth. Do not use harsh or abrasive cleanser.
6. Using incompatible hardware might cause damage to product.

STEP 1

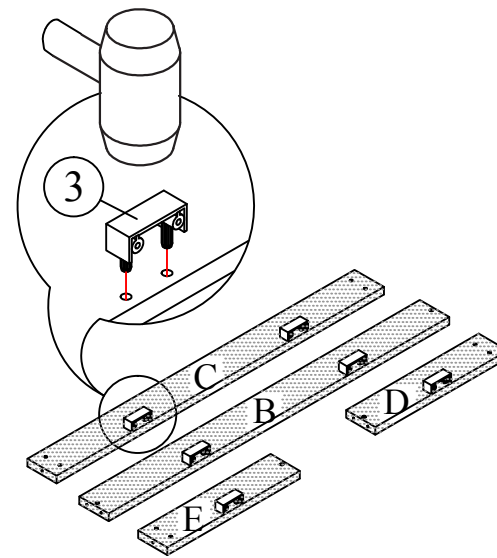

STEP 2

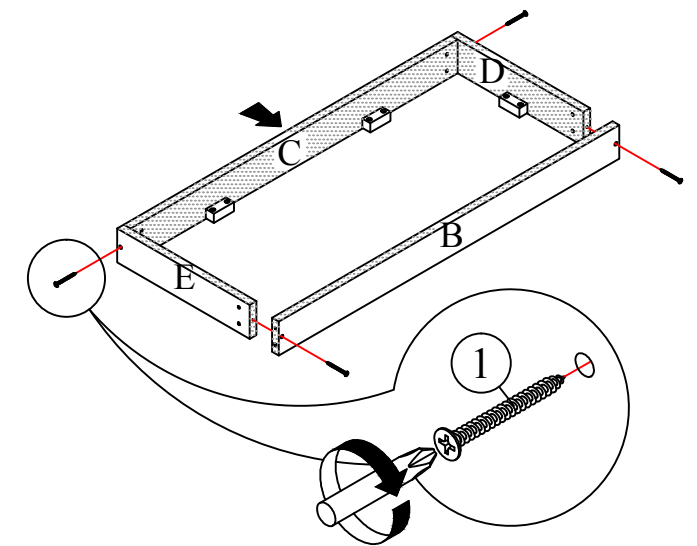

STEP 3

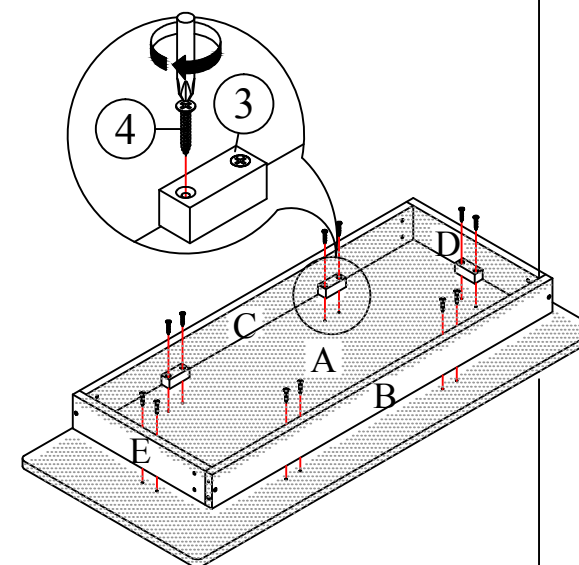

STEP 4

