

THKFBV121GN0BW

INSTALLATION INSTRUCTIONS

*The vessel and faucet set is not included

DIMENSIONS

Unit:inch

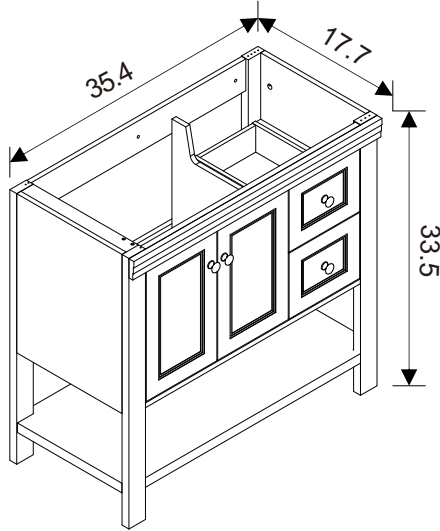

ASSEMBLY DIAGRAM

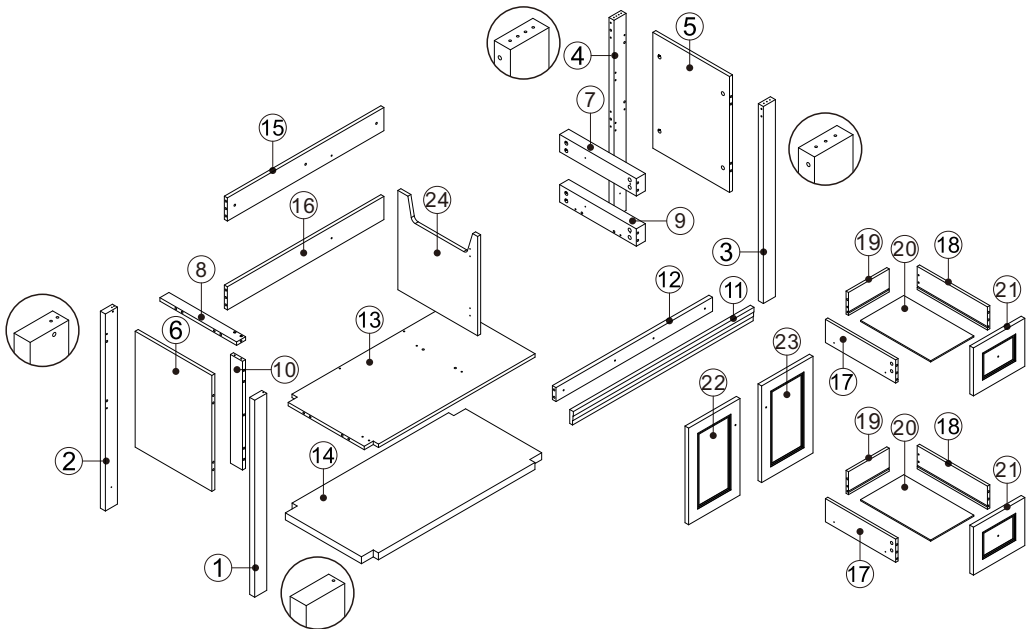

YOU MAY NEED (NOT SUPPLIED)

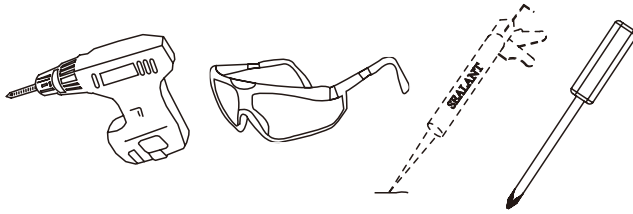

INSTALLATIONS

STEP 1

HARDWARE LIST	
A  45PCS	

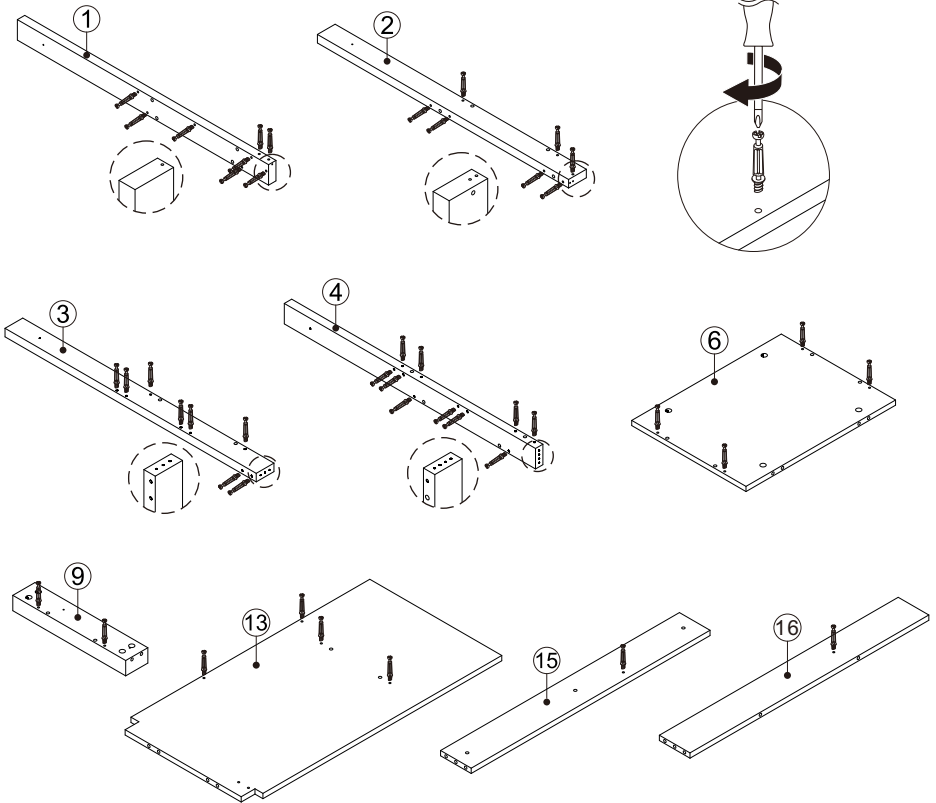

- Insert the Cam Screw into the shelves above.

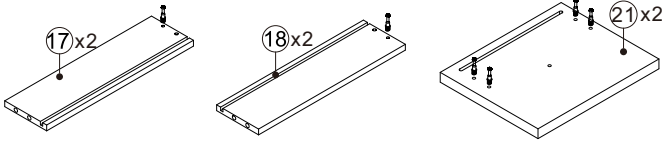

STEP 2

HARDWARE LIST	
C  12PCS	



- Insert the Cam Screw into the shelves above.

STEP 3

HARDWARE LIST	
B  22PCS	

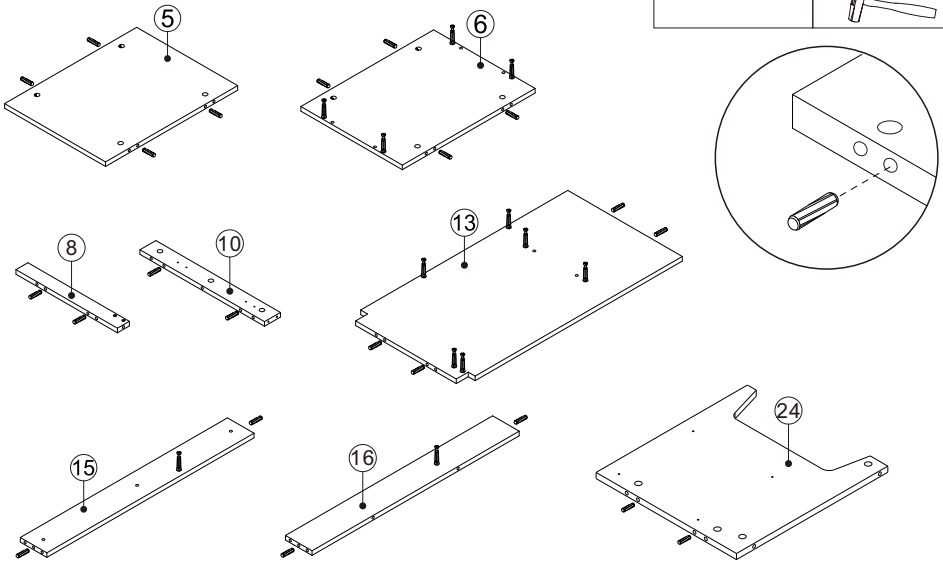

- Insert the wooden dowel pins into the shelves.

STEP 4

HARDWARE LIST	
D  4PCS	

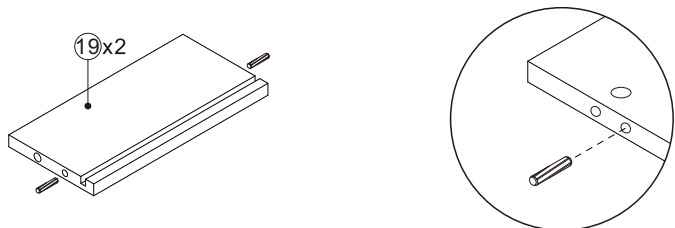

STEP 5

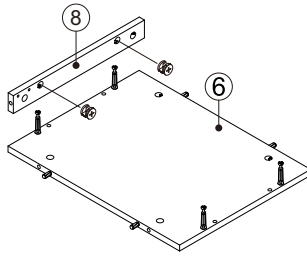

HARDWARE LIST		
A		2PCS
		

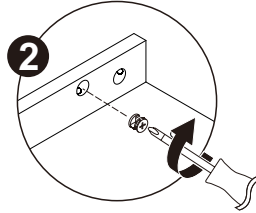
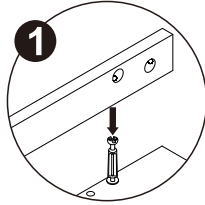

- Refer to the illustration, Insert the boards #8 into the board #6. Then tighten the cam lock.

STEP 6

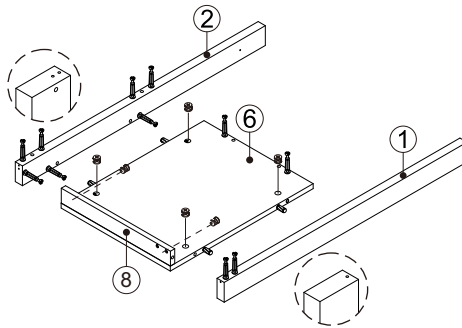



HARDWARE LIST		
A		6PCS
		

- Refer to the illustration, Insert the boards #6, #8 into the board #1, #2. Then tighten the cam lock.

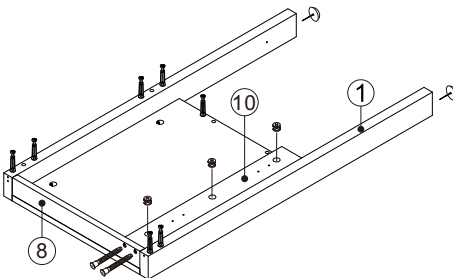
STEP 7

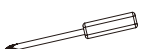

HARDWARE LIST		
A		3PCS
H		2PCS
T		2PCS
		

- Refer to the illustration, Insert the boards #10 into the board #1. Then tighten the cam lock. Connect the board #8 and #10 with screws.

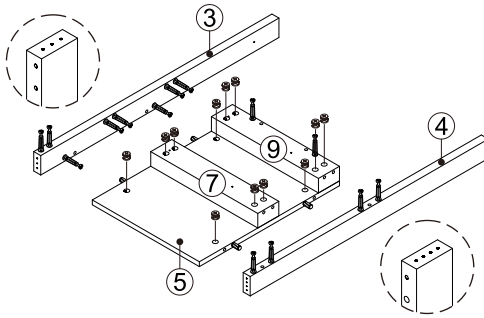

STEP 8



HARDWARE LIST		
A		12PCS
		

- Refer to the illustration, Insert the boards #5,#7,#9 into the board #3,#4. Then tighten the cam lock.

STEP 9

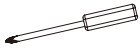
HARDWARE LIST		
G		2PCS
F		6PCS
H		2PCS
		

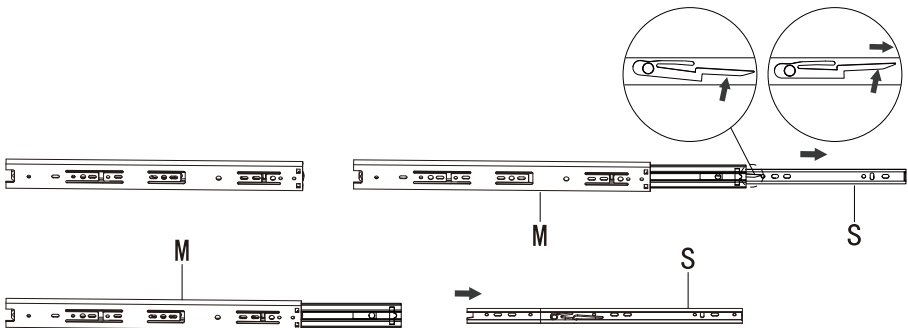

- Keep pressing here, then pull out to devide the slide.

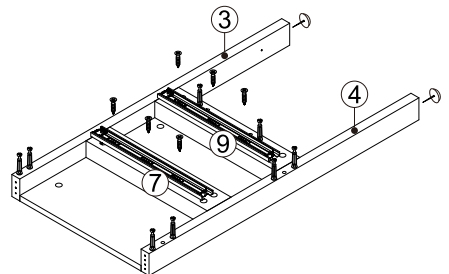
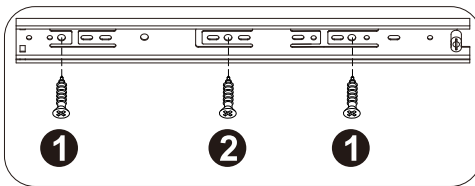

- Refer to the illustration to fix the Slide rails to the board #7,#9 with screws.

STEP 10

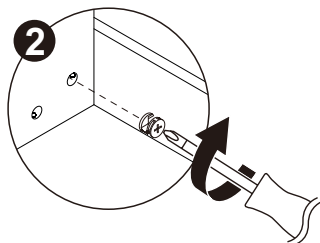
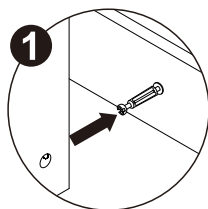
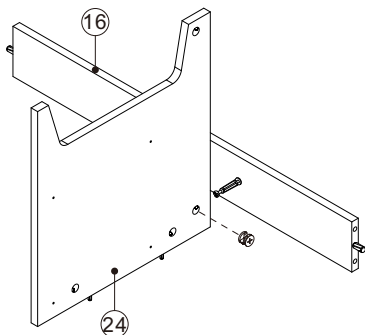

HARDWARE LIST		
A		1PCS
		

- Refer to the illustration, Insert the boards #16 into the board #24. Then tighten the cam lock.

STEP 11

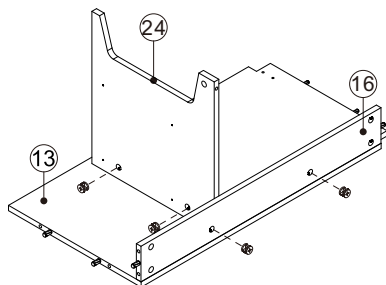

HARDWARE LIST		
A		4PCS
		

- Refer to the illustration, The shelf already assembled #16,#24 on the board #13. Then tighten the cam lock.

STEP 12

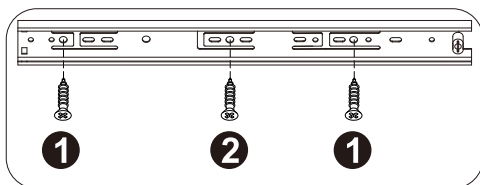
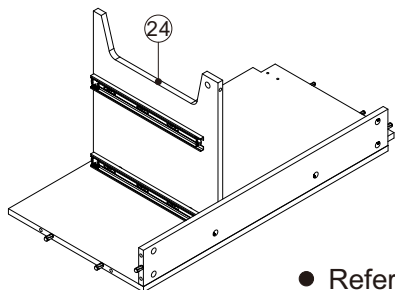

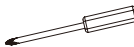
HARDWARE LIST		
G		2PCS
F		6PCS
		

- Refer to the illustration to fix the slide rails to the board #24 with screws.

STEP 13

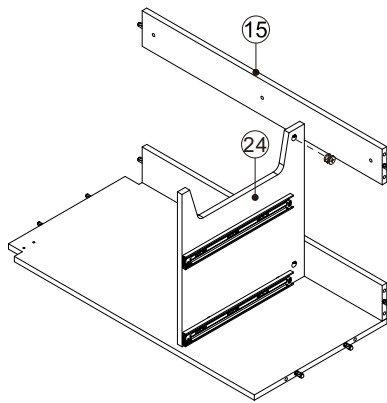

HARDWARE LIST			
A		1PCS	

- Refer to the illustration, Insert the boards #15 into the board #24. Then tighten the cam lock.

STEP 14

HARDWARE LIST			
A		16PCS	

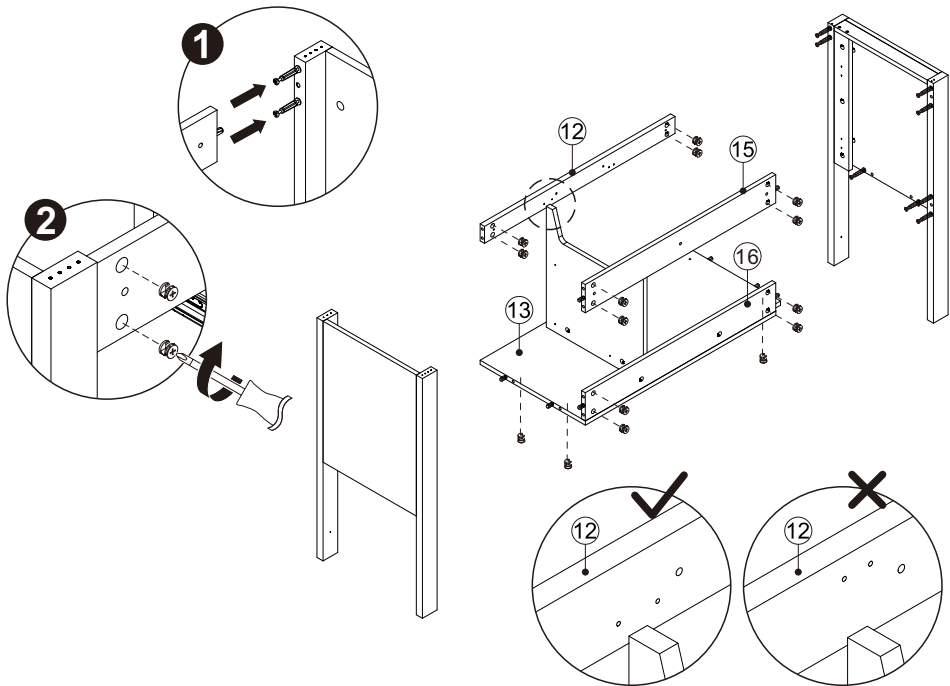

- Refer to the illustration, #12, #13, #15, #16 on the shelf already assembled #1, #2, #6, #8, #10 and #3, #4, #5, #7, #9. Then tighten the cam lock.

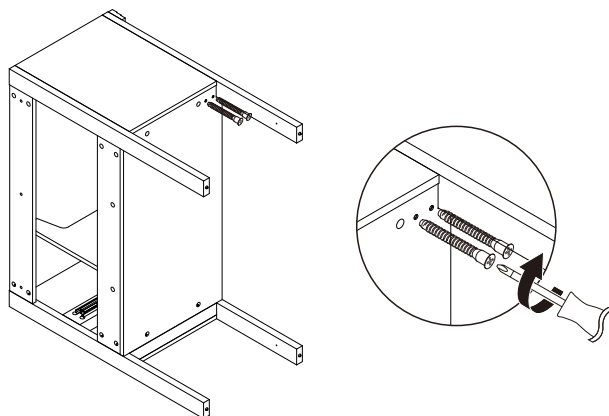

STEP 15

HARDWARE LIST	
T	 2PCS
	



- Refer to the illustration, Connect the board #10 and #13 with screws.

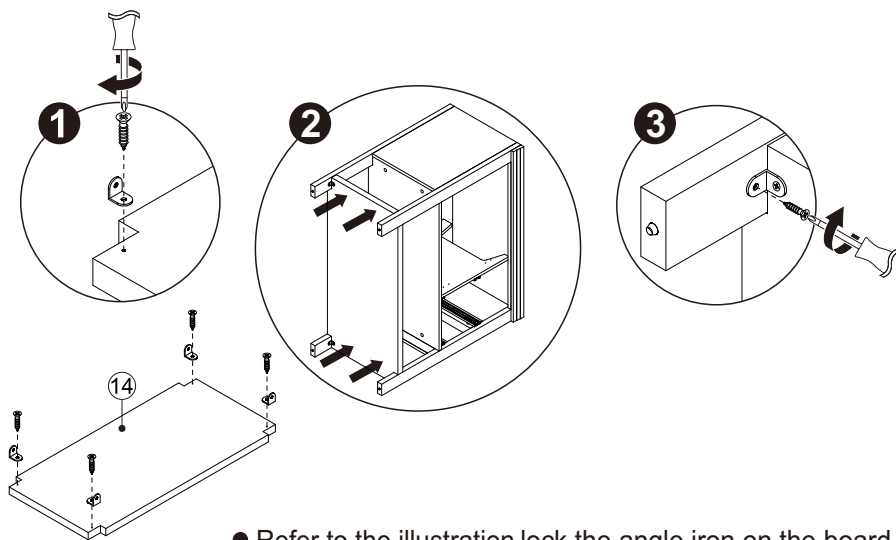

STEP 16

HARDWARE LIST	
E	 8PCS
L	 4PCS
	



- Refer to the illustration, lock the angle iron on the board #14, #1, #2, #3, #4 by screws.

STEP 17

HARDWARE LIST		
E		6PCS
S		1PCS
U		1PCS

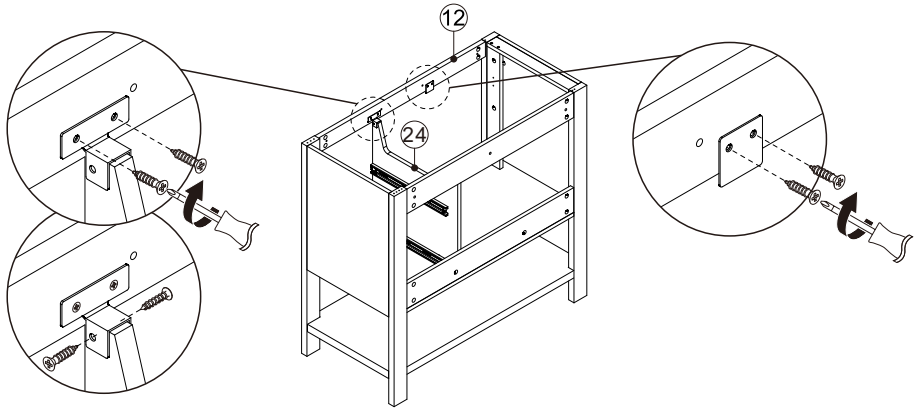
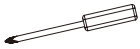

- Refer to the illustration,lock the angle iron on the board #12 #24 by screws.



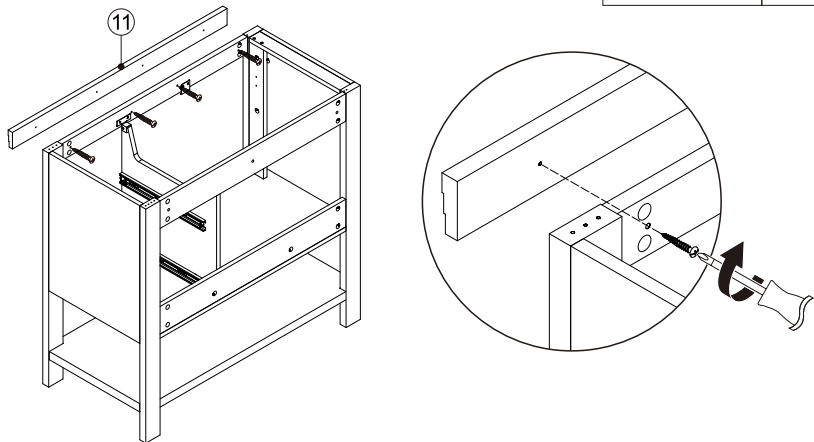

STEP 18

HARDWARE LIST		
I		4PCS



- Refer to the illustration,Connect the board #11 and #12 with screws.

STEP 19

HARDWARE LIST		
E		24PCS
J		2PCS
Q		2PCS
R		2PCS
P		2PCS

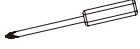
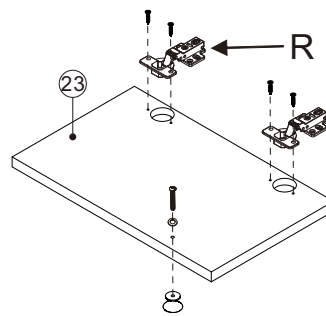
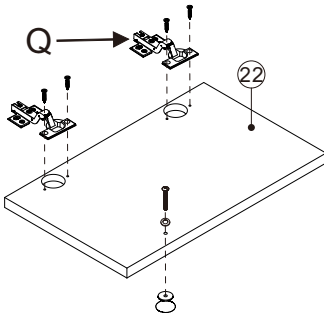
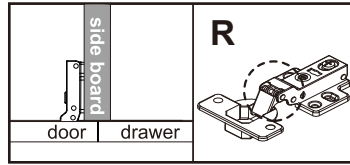
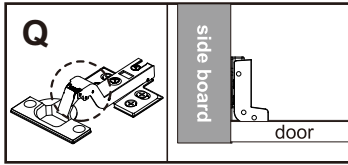
- Use Screws to install the handle and apply Screws to fix the hinge on the shelf #22. Then use Screws to connect the hinge bracket to the cabinet. Repeat these steps for the other door.

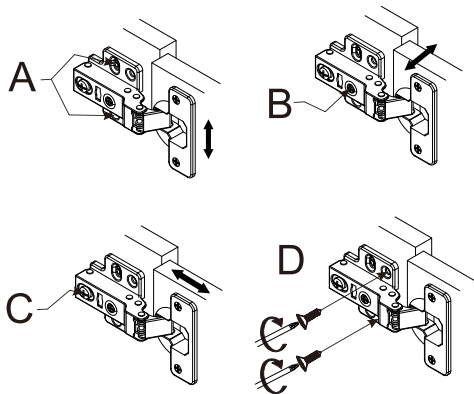
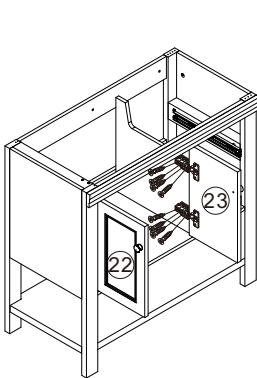

- A. Height adjustment
- B. Side to side adjustment
- C. Depth adjustment
- D. After adjustment A/B/C, tighten screws.

- To ensure proper cabinet alignment, refer to the above illustrations for instructions about adjusting the cabinet height, depth and lateral movement.

STEP 20

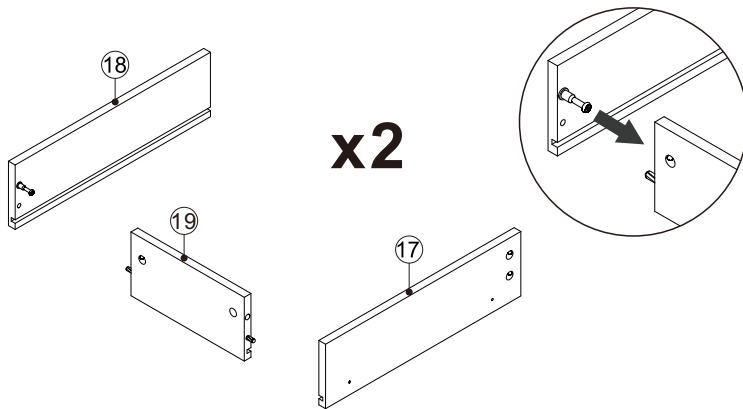

- Refer to the illustration, Insert the boards #17, #18, #19.

STEP 21

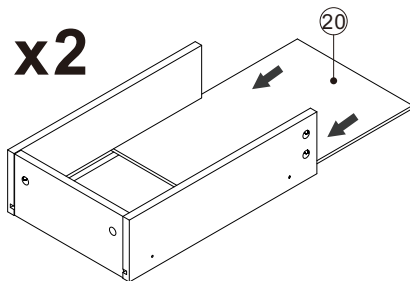

- Refer to the illustration, Insert the boards #20 into the finished shelf.

STEP 22

HARDWARE LIST			
C		4PCS	

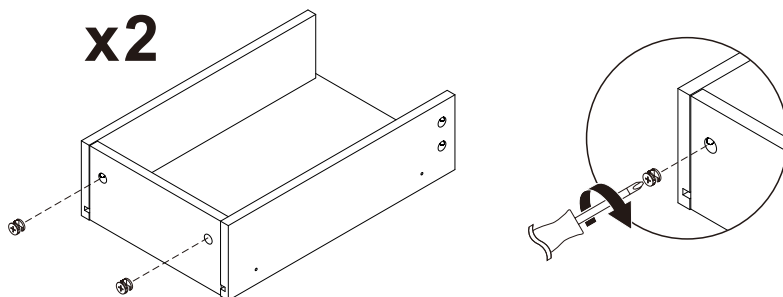

- Refer to the illustration, tighten the cam lock.

STEP 23



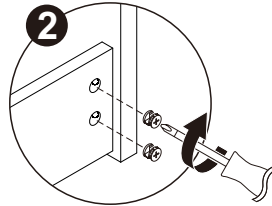
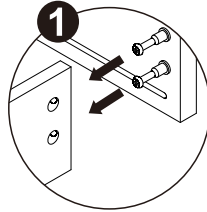
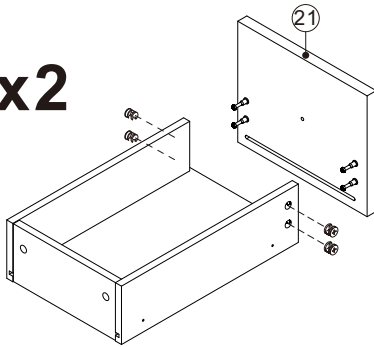

HARDWARE LIST			
C		8PCS	

x2

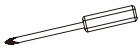

- Refer to the illustration, Insert the board #21 into the finished shelf. Then tighten the cam lock.

STEP 24

HARDWARE LIST			
J		2PCS	
G		4PCS	
F		12PCS	
K		2PCS	

x2

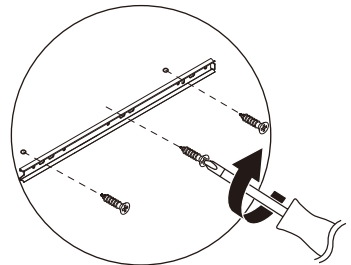
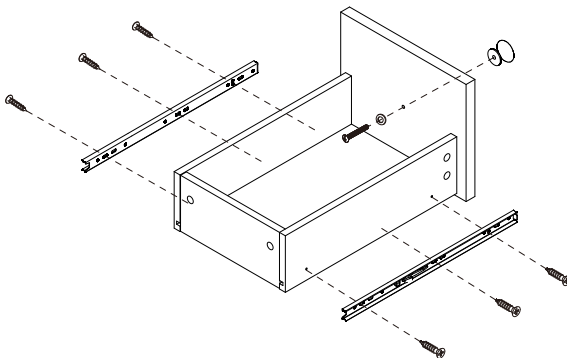

- Refer to the illustration, Apply Screws to fix the slides on the boards #17,#18. Use Screws to install the handle.



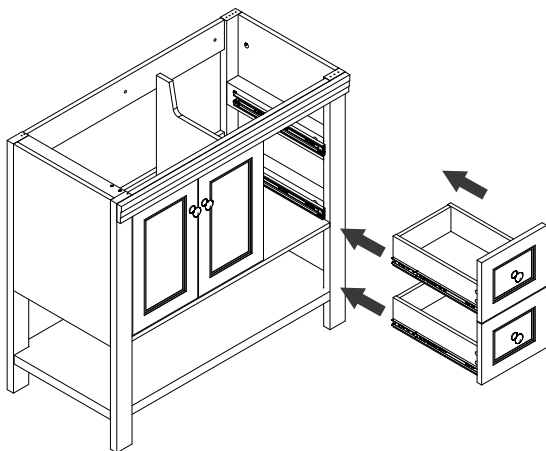

STEP 25

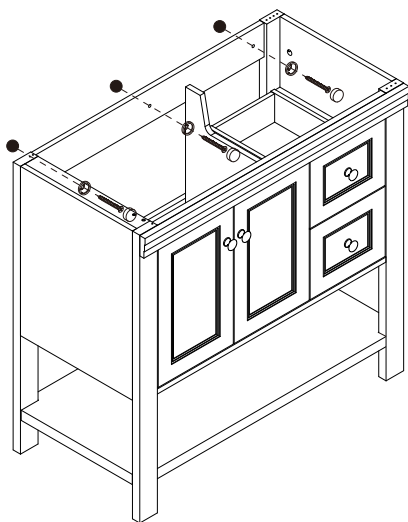

- Assembled drawers are loaded onto cabinets.

STEP 26



HARDWARE LIST			
N		3PCS	
N		3PCS	
N		3PCS	
N		3PCS	

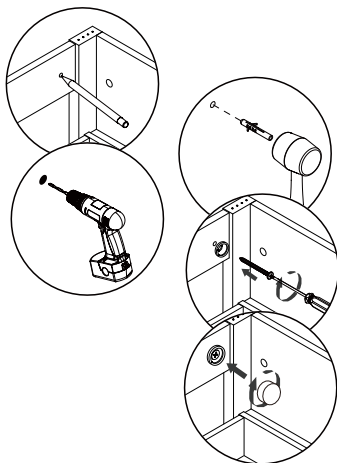

- Refer to the illustration, Draw the spacing between the walls on the cabinet, punch holes in the wall, and fix the cabinet to the wall with screws. Then tighten the nut cover.

STEP 27

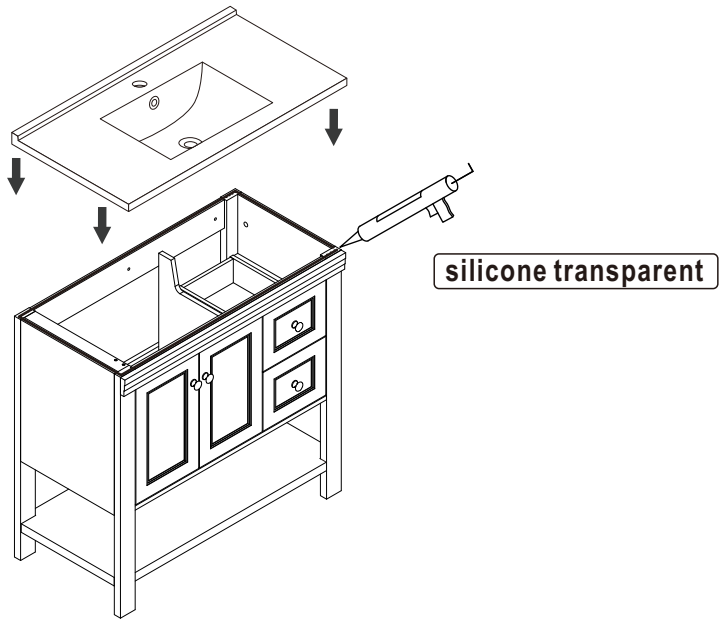

STEP 28

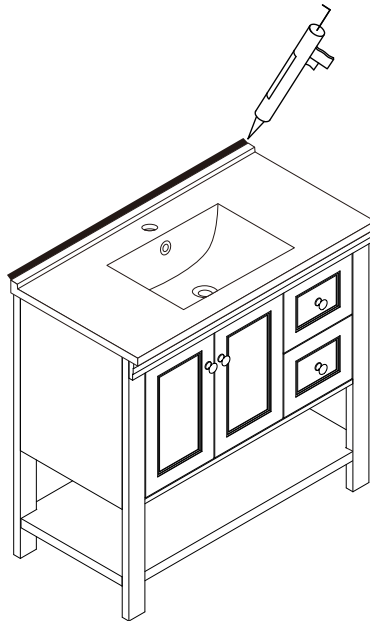

- To help prevent mildew, apply sealant to the space between the wall and the edge of the cabinet.

CARE AND CLEANING

1. Many cleansers contain abrasive and chemical substance which is not suitable for cleaning stainless steel, enamel, plating or plastic products. You may use mild cleansers or soaps to clean the surfaces. Wipe any splashes of cleaner solutions from the surface with a clean soft cloth.
2. Maintain ventilation in the bathroom and separate the dry area from the damp one if conditions permit. Try to open the door and windows of the bathroom to maintain adequate ventilation.
3. This cabinet is built to withstand normal bathroom humidity. For best results, keep this vanity dry and take necessary steps to minimize bathroom humidity by opening windows and doors and using the exhaust fan (if available).
4. To maintain the cabinet door, clean and wipe the door regularly with a soft cloth. Wipe condensation with a dry, soft cloth. Keep away from res and high temperatures.
5. Please do not sit, lean or step on the basin cabinet.

FEEDBACK ★★★★★

Thank you very much for purchasing from us.

We have always been trying to provide the best service and reliable products for every customer.

We sincerely hope you will be satisfied with our products and leave us FIVE STARS and POSITIVE feedback/ review in our page.

However, accident may happen sometimes, please contact us to resolve any issue before leaving a negative feedback.

Many thanks and welcome to our shop again!

Contact number: (323)-393-8260

E-mail: service@eclifeusa.com