

# Assembly Instructions

820342 Console Table - Light OAK  
820345 Console Table - Smoked OAK

**Product Issues? Please Call Us Before Contacting Your Retailer At 1-800-549-3300**

**Email [customerservice@mshome.co](mailto:customerservice@mshome.co), or visit [www.mshome.co](http://www.mshome.co)**

**We can help with Assembly Issues, Part Requests, Damages, & All Other Product  
Related Questions**

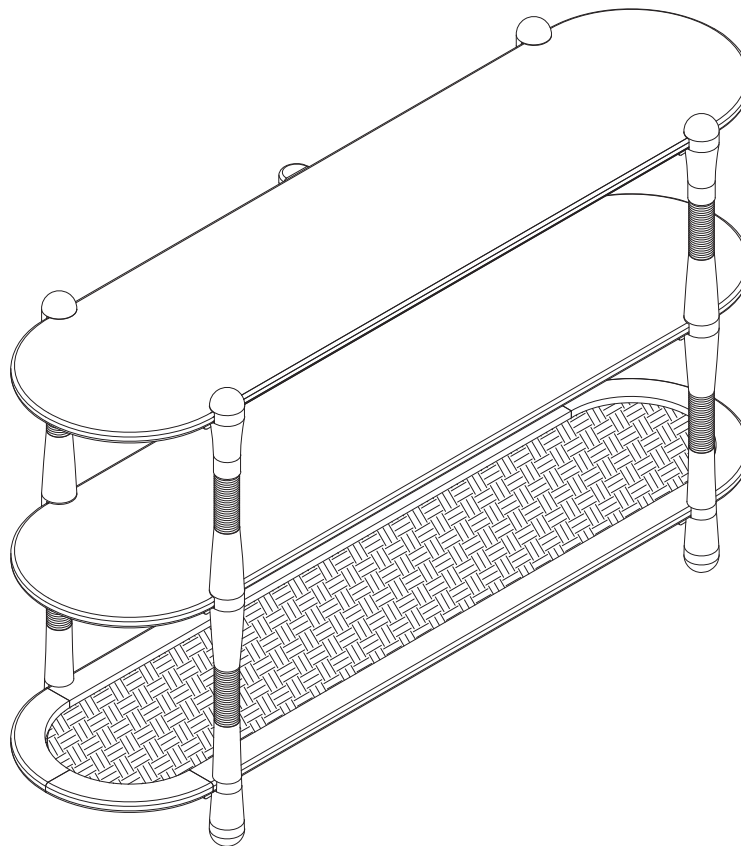

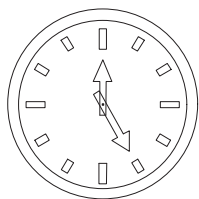

25 min

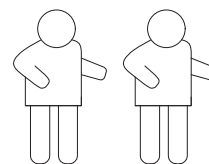

Two People Required  
for Assembly

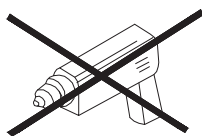
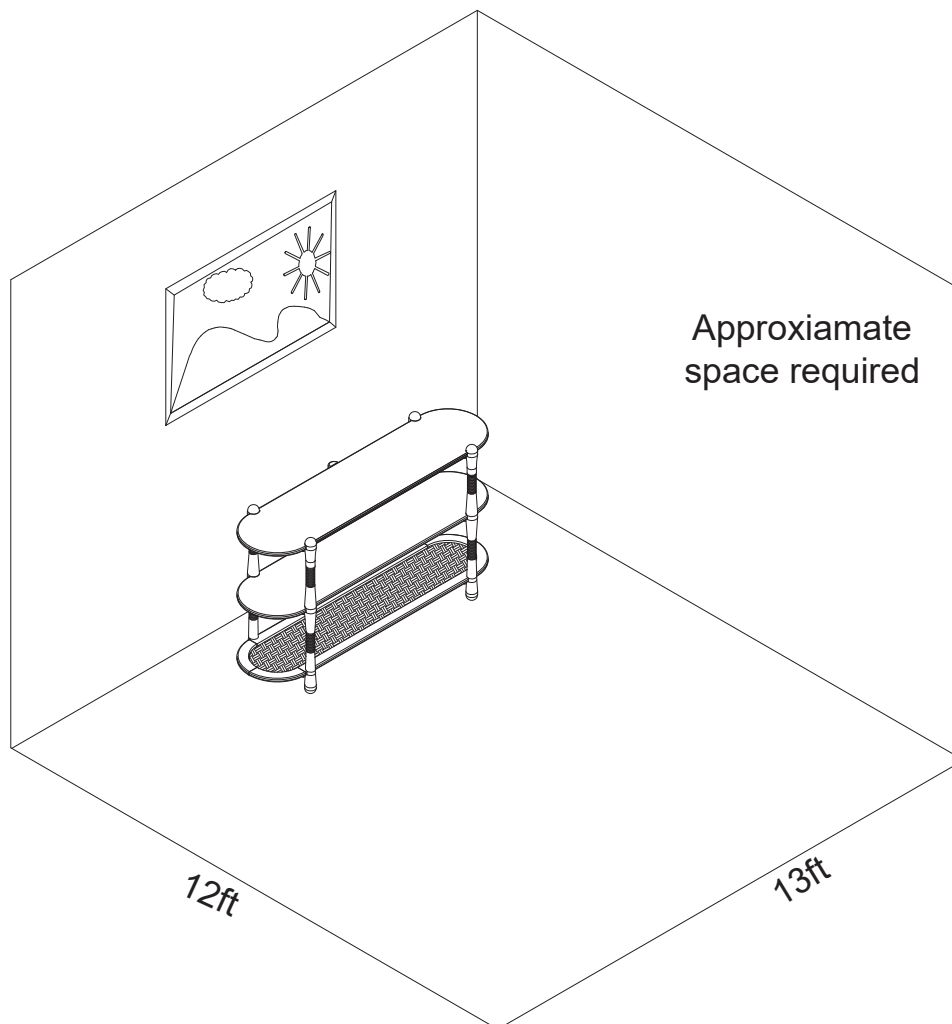



Do Not Use Power Tools

## Parts Included:

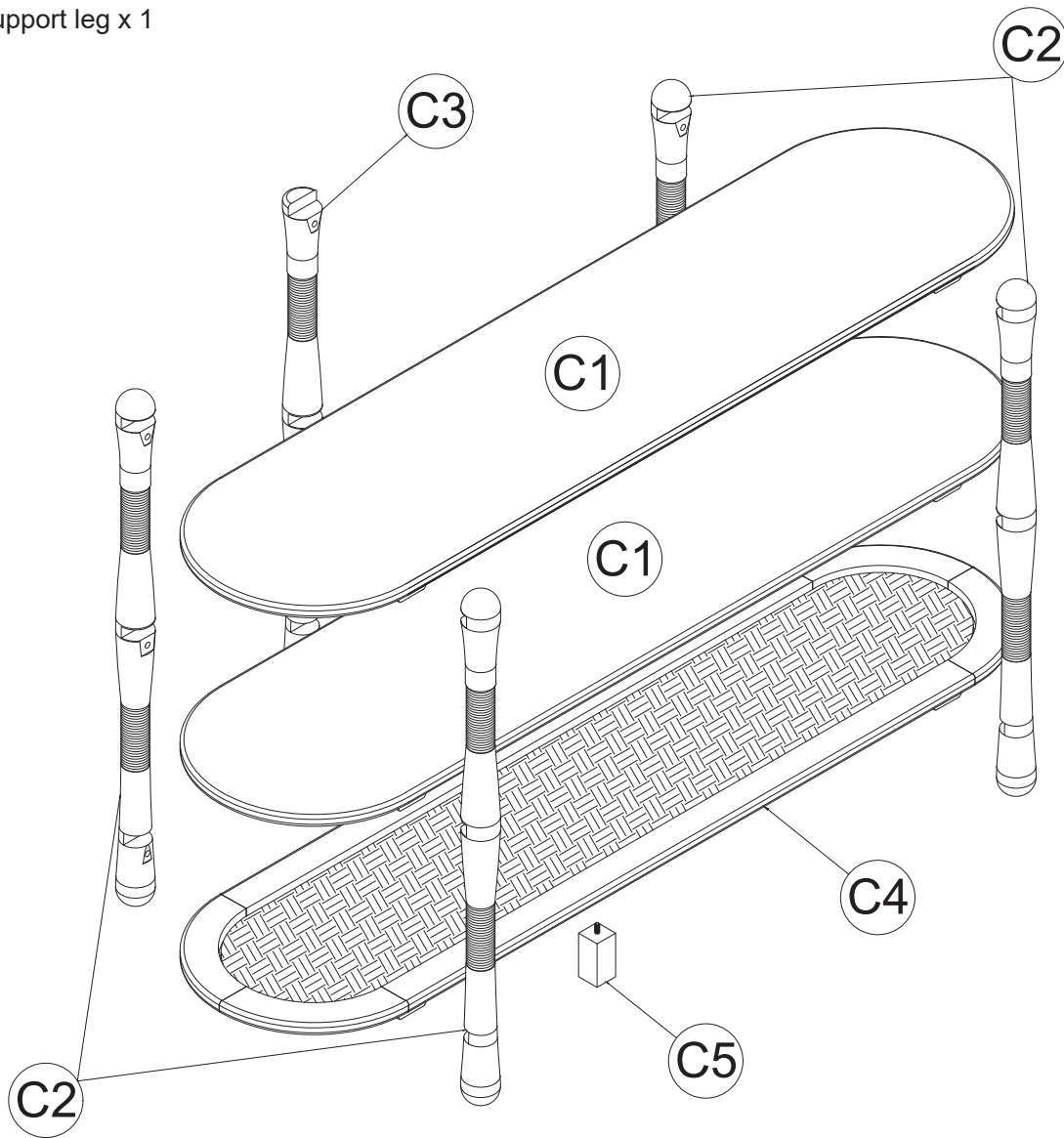
- (C1) Top Panel & Middle Panel x2
- (C2) Side Legs x 4
- (C3) Middle leg x 1
- (C4) Bottom Frame x 1
- (C5) Support leg x 1

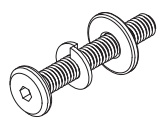
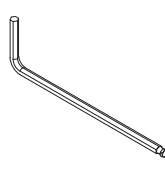

## ✓ Hardware Pack:

<p><b>A</b></p>  <p>Ø6 x 35 (mm): 15pcs</p>	<p><b>B</b></p>  <p>Ø4 : 1pc</p>	<p><b>C</b></p> 
--	---	---

1

A x 4



Ø6 x 35 (mm)

B



Position an object at least 2" high beneath the top panel before continuing with the assembly  
In this step, assemble only the four legs first, following the illustration.

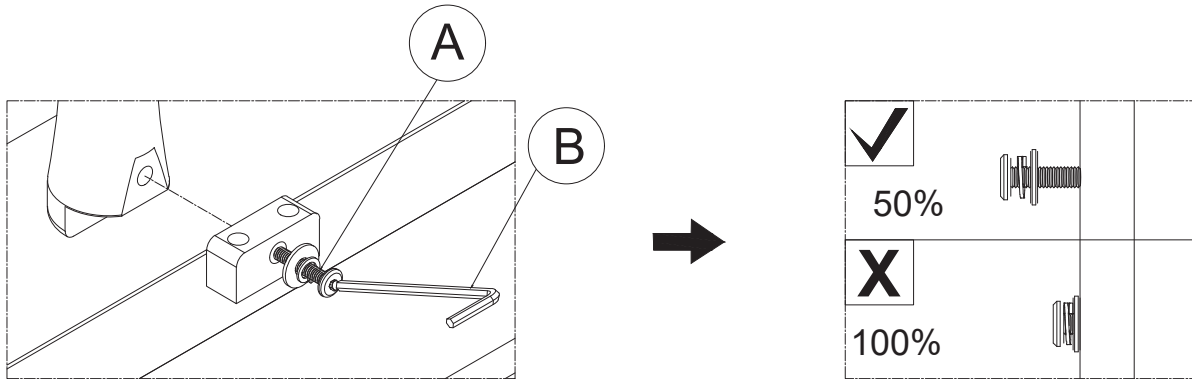

Do not fully tighten the bolts at this stage  
until all the parts are in position

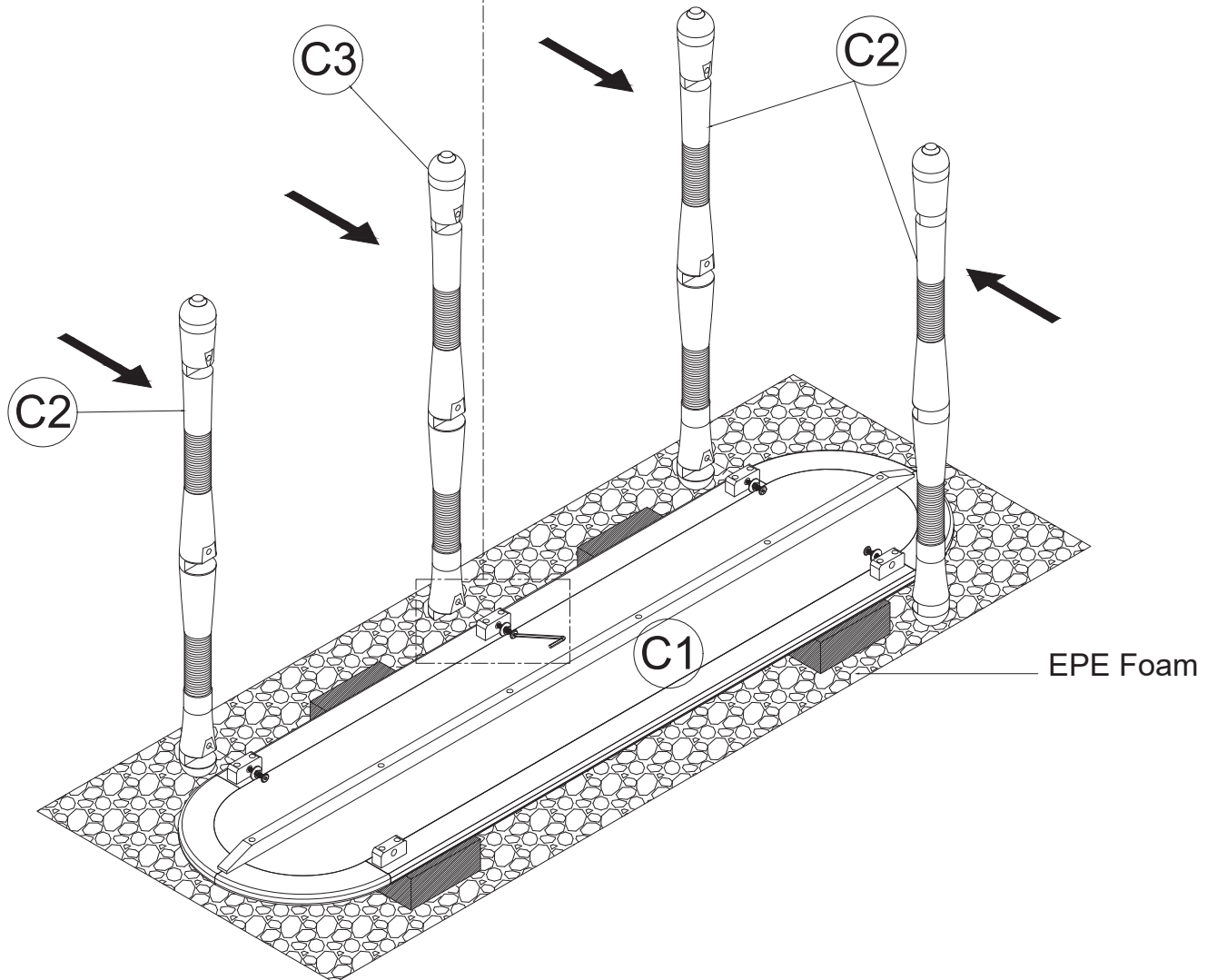

2

A x 4



Ø6 x 35 (mm)

B

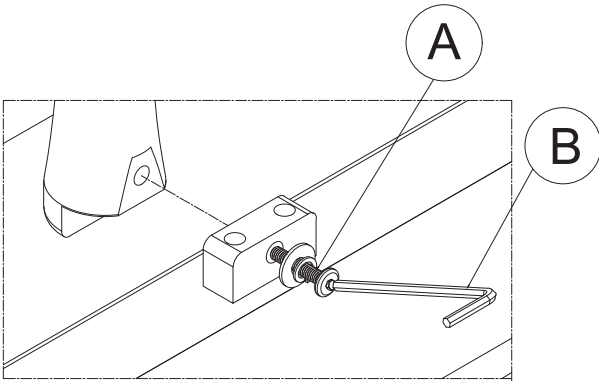

✓		
50%		
X		
100%		

Do not fully tighten the bolts at this stage until all the parts are in position

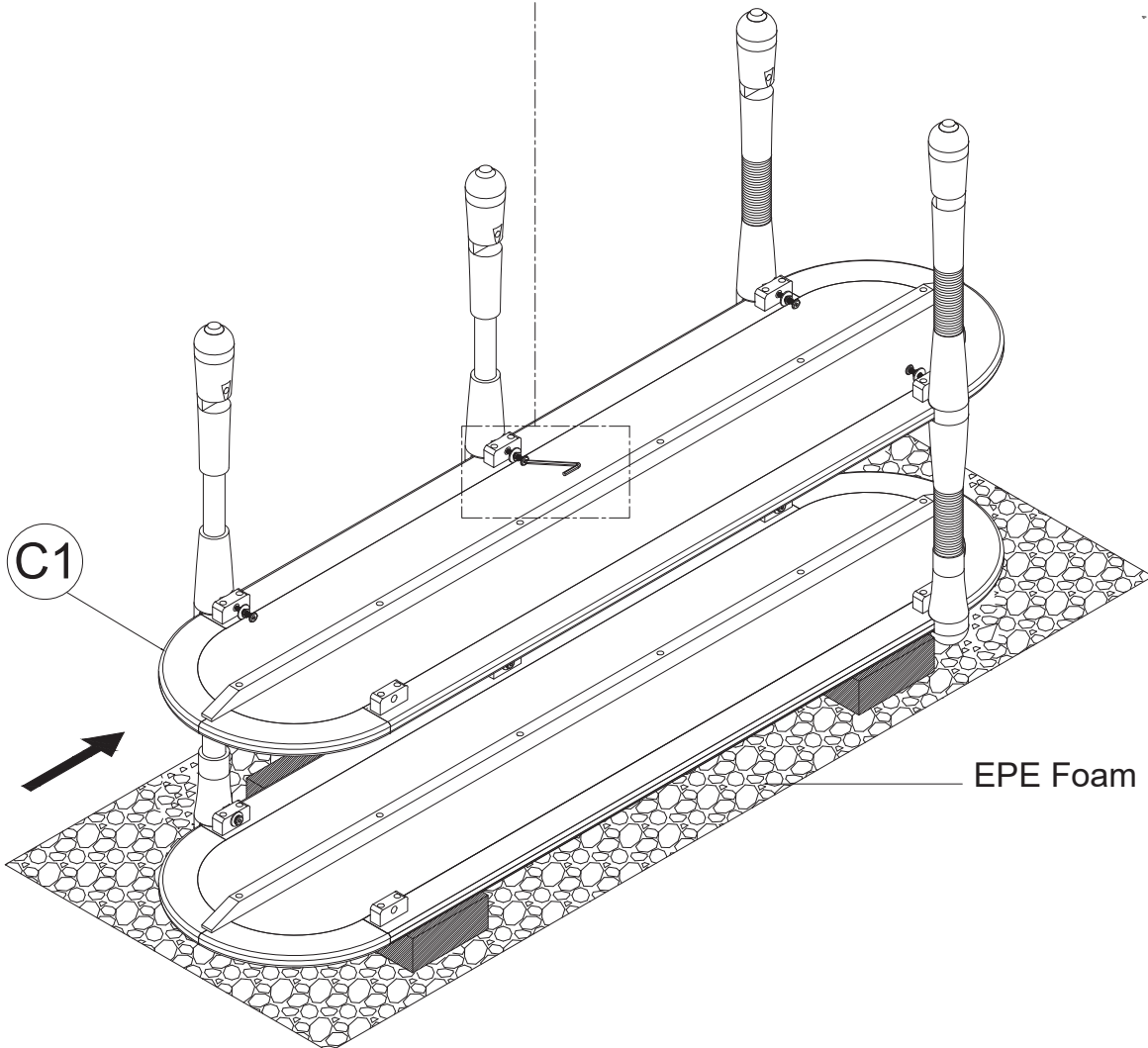

3

A x 4



Ø6 x 35 (mm)

B

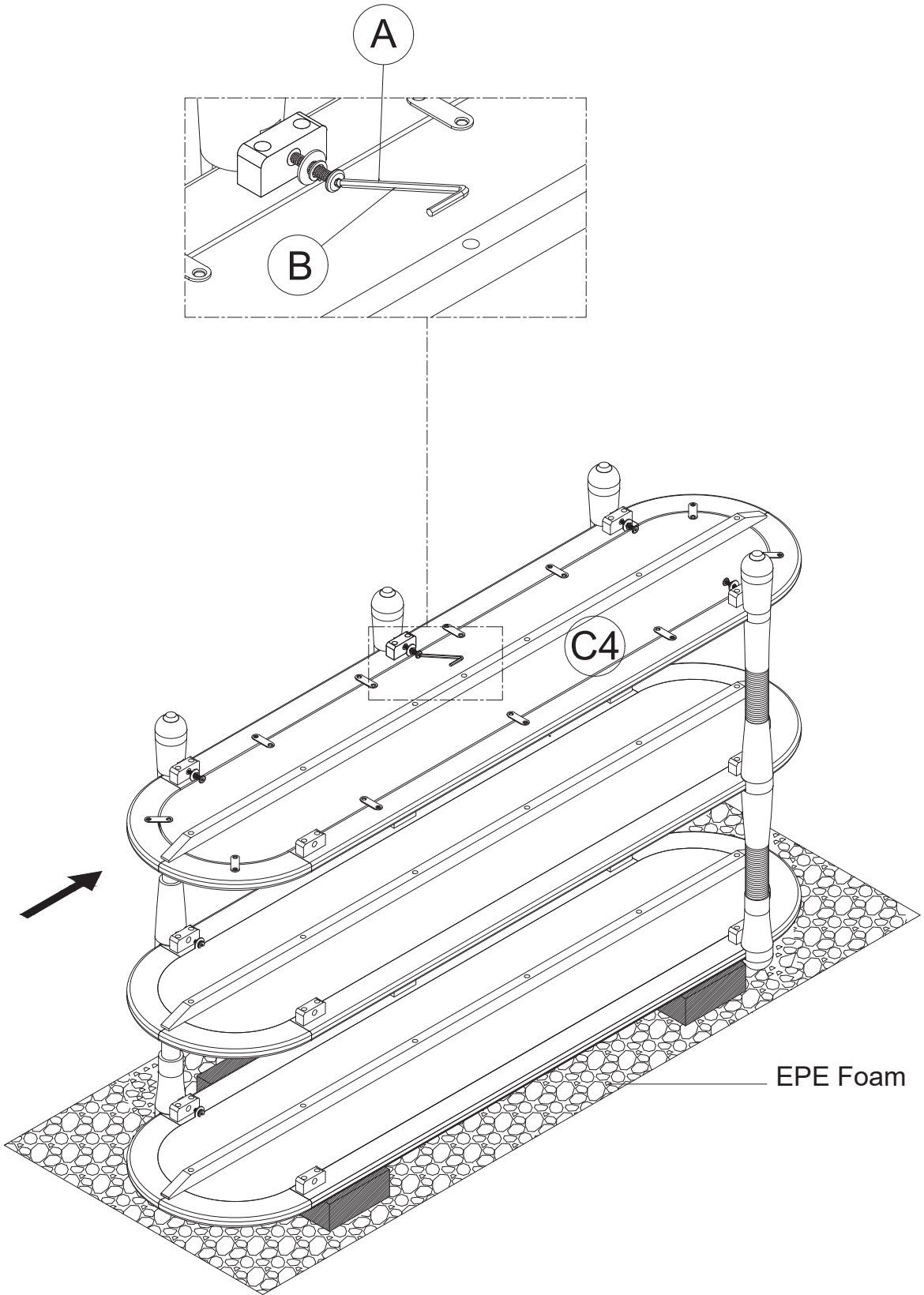

4

A x 3



Ø6 x 35 (mm)

B



Use the leveling base to attach to the legs for balance.  
If the table is rocking, adjust the adjuster until the condition gets better.

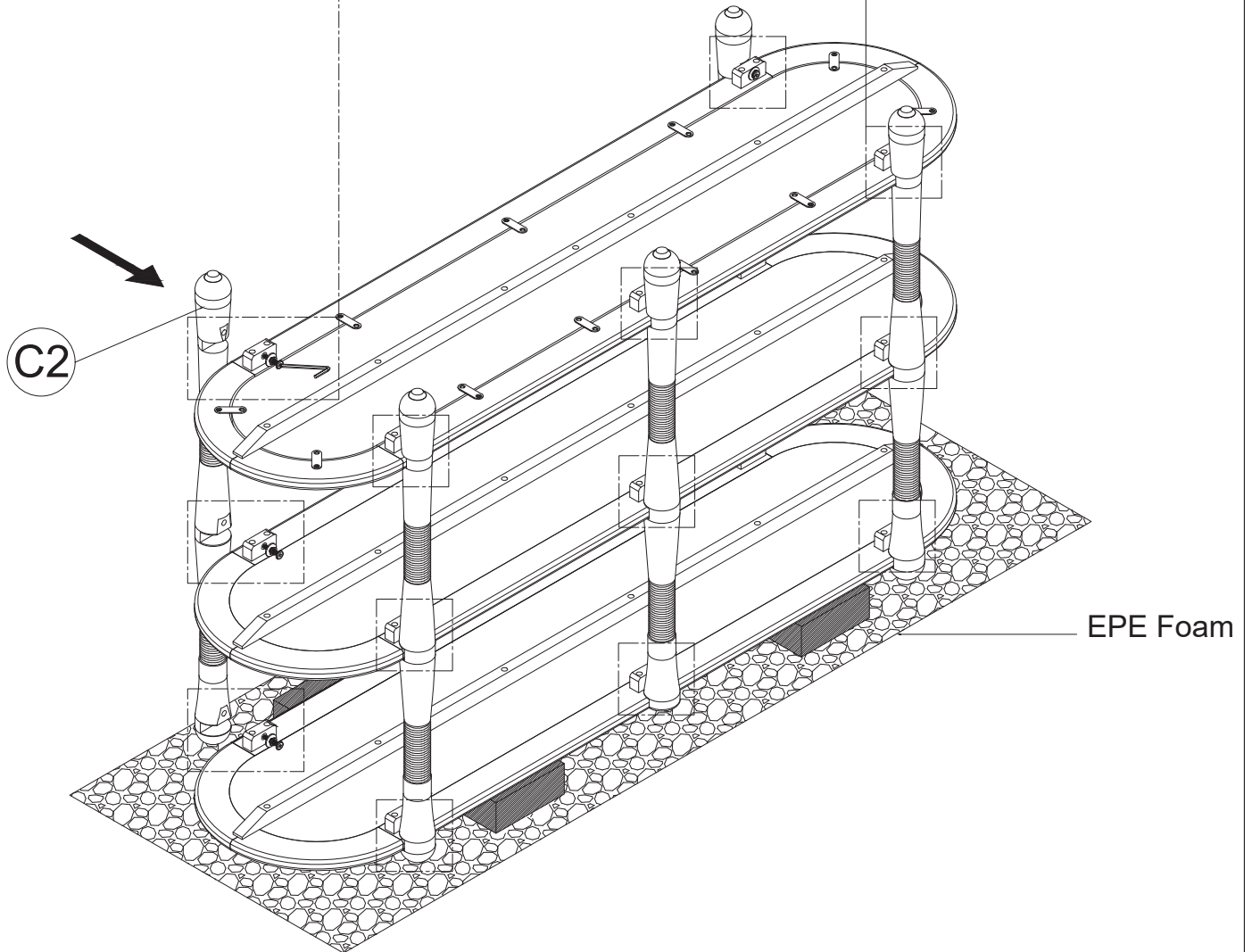
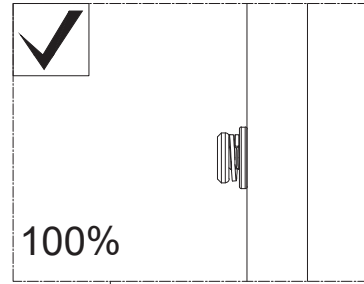
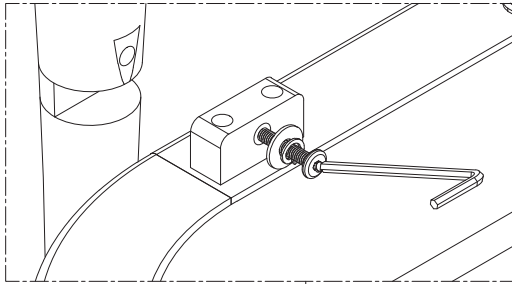

5

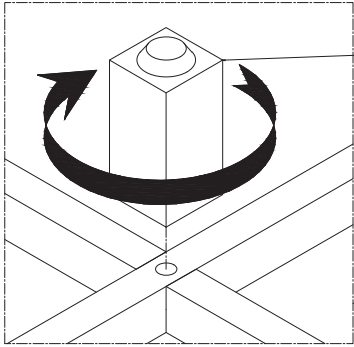

C5

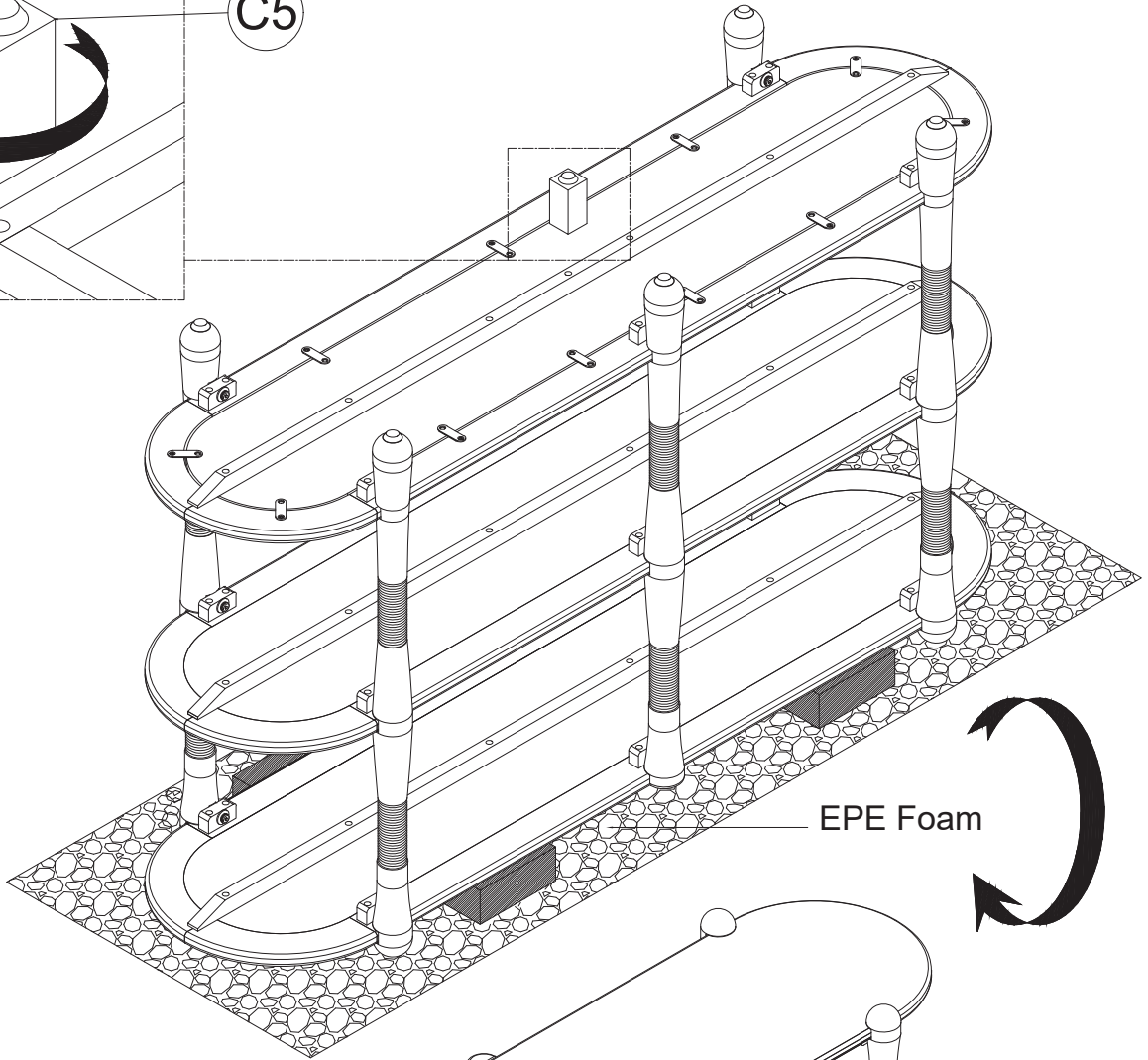

EPE Foam

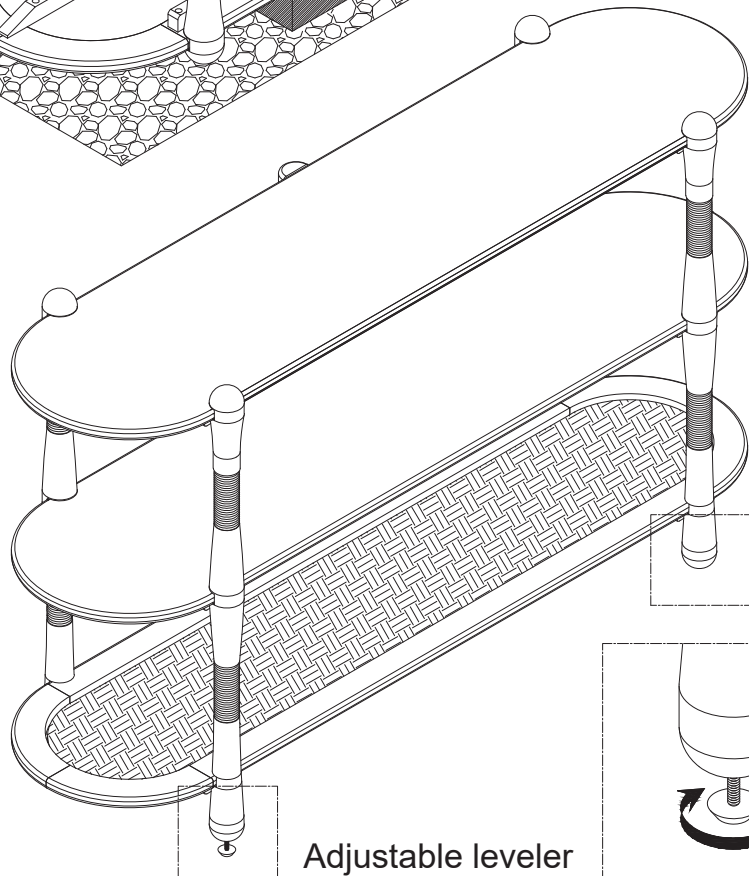

Adjustable leveler

8-9

6

c

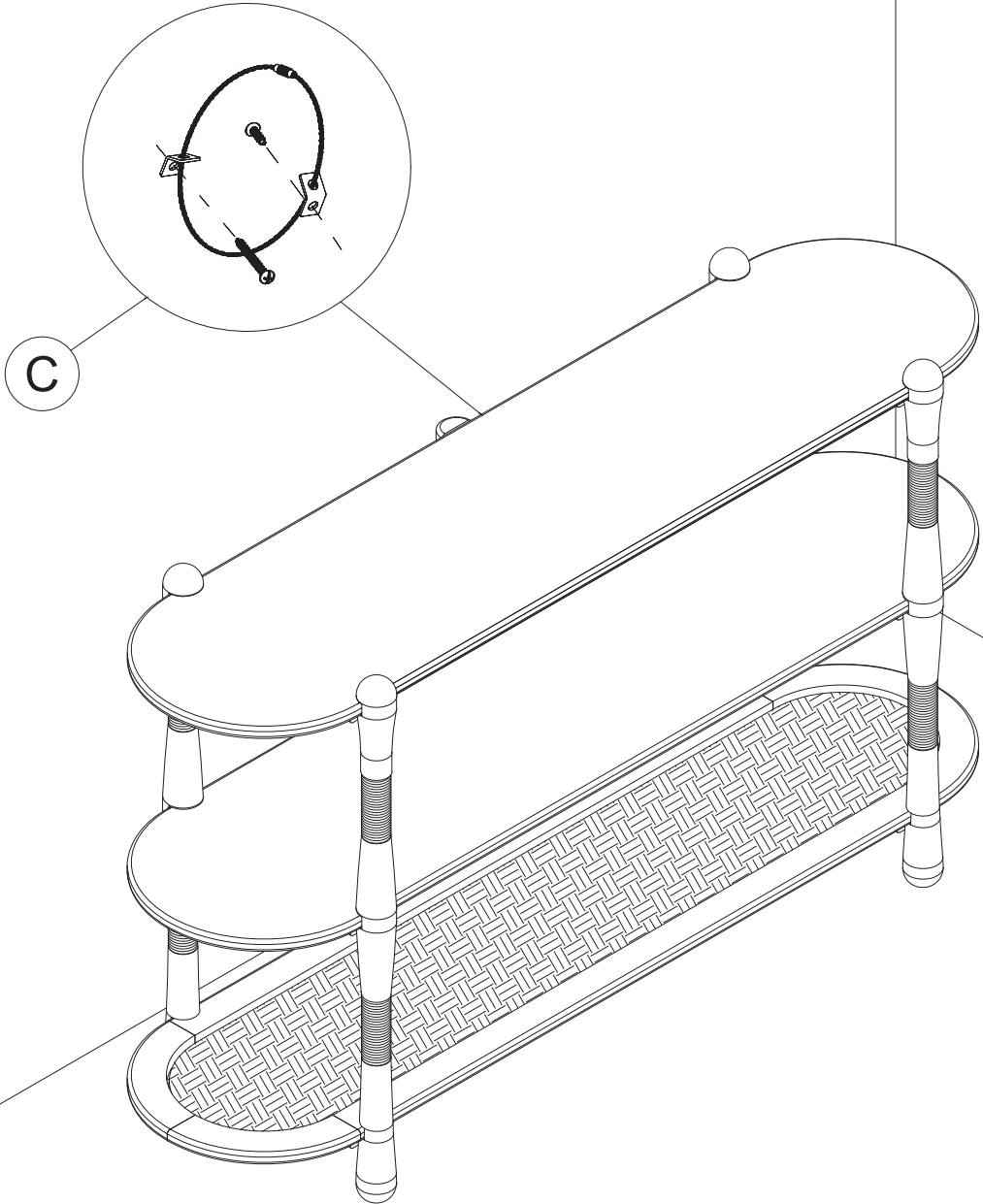



## Replacement Part Form

Have an issue? Need a replacement part?

Please E-mail us before contacting your retailer, we will be happy to fix your issue.

This process will be hassle free! We will replace your part for free!

Please follow these easy steps below.

You will need to E-mail *Martin Svensson Home* Customer Service: [Customerservice@mshome.co](mailto:Customerservice@mshome.co)  
(Please note it is .CO not .com)

Please scan or take a picture of this form filled out.

1. **Customer Name:** \_\_\_\_\_

2. **SKU# with issue:** \_\_\_\_\_

3. **Replacement Part # needed** \_\_\_\_\_

\*Please reference the Assembly Instructions to identify needed part #'s

4. **Photos of the Damaged Part** (please include in the e-mail)

5. **Brief description of the part issue:** \_\_\_\_\_

6. **Proof of Purchase** (please provide a copy of your purchase receipt)

7. **Ship to Address:** \_\_\_\_\_

\_\_\_\_\_  
\_\_\_\_\_

8. **Other contact information:**

**Email Address** \_\_\_\_\_

**Phone #** \_\_\_\_\_

\*If possible, could you please provide the UPS or FedEx tracking from original shipment \_\_\_\_\_

\*If possible, could you please provide the P.O. # - information found on back/underneath product \_\_\_\_\_

\*If you have any other question, we are happy to assist with assembly questions or all other parts related questions. Thank you for your purchase!