

# CHAIR SIDE TABLE CHARGING STATION

## ASSEMBLY INSTRUCTIONS

Before assembling your side table, please read through these instructions carefully and familiarize yourself with the different parts.

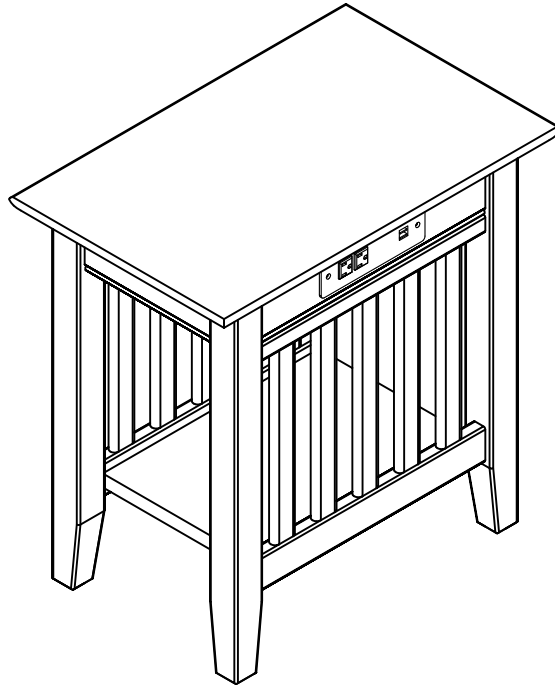

NOTE: WE INCLUDE SPARE HARDWARE IN CASE DAMAGE OCCURS DURING ASSEMBLY.

**A** Flat washer - 4 pcs

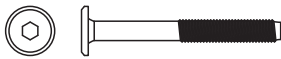

**B** JCB M8 - 4 pcs  
Spare - 1 pc

**C** Allen wrench - 1 pc



**D** Wooden dowel 1/4" X 1 1/4" - 4 pcs  
Spare - 1 pc

**E** Wooden dowel 3/8 X 1 1/4" - 4 pcs  
Spare - 1 pc

**F** Wood screw - 8 pcs  
Spare - 2 pcs

## PARTS LIST

- 01** TOP PANEL 1 PC
- 02** LEG 4 PCS
- 03** SIDE PANEL 2 PCS
- 04** LOWER SHELF 1 PC

PO:

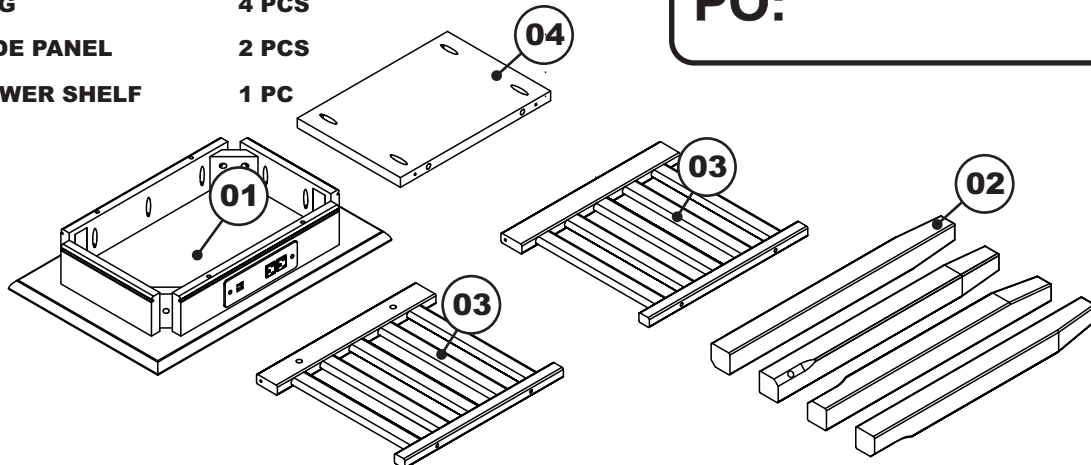

## CHAIR SIDE TABLE CHARGING STATION

### Step 1

Attach the legs (02) to the top panel (01) using flat washers (A) and JCB (B), tighten with Allen wrench (C), as shown below.

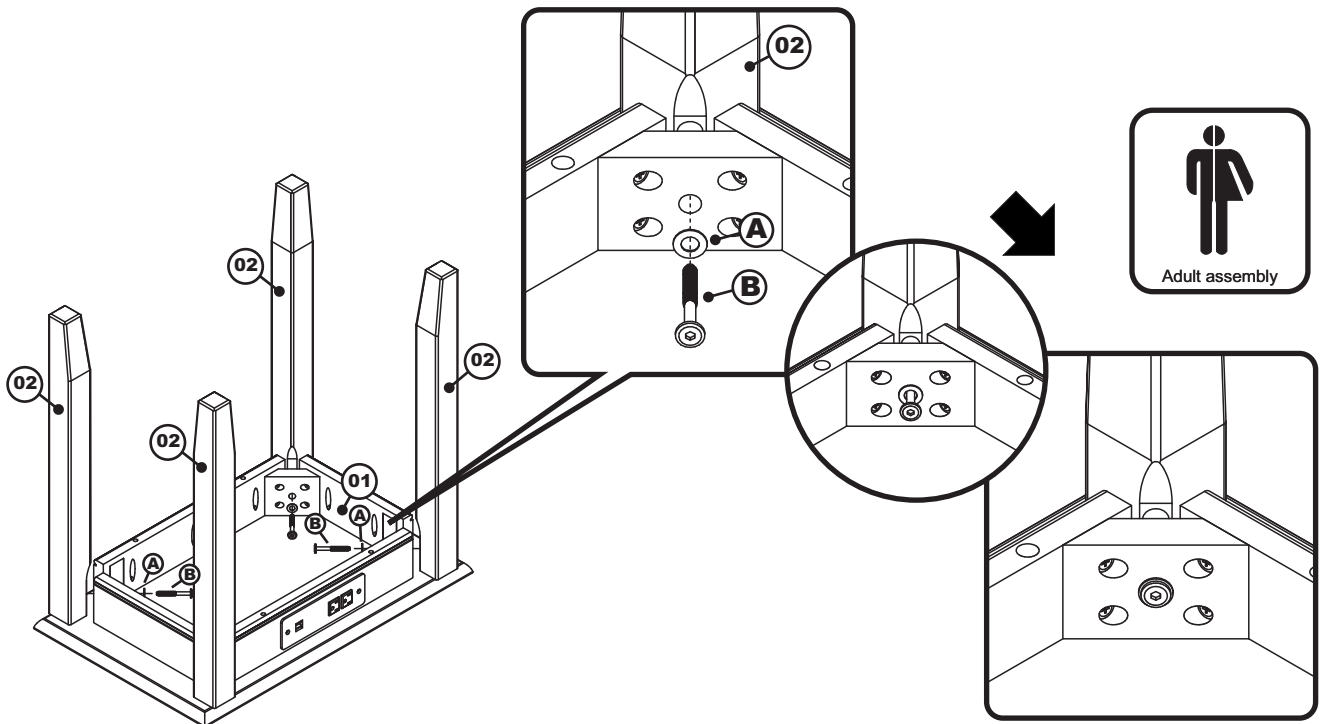

### STEP 2

Install wooden dowels (D) and (E) into the locator holes on (03) and (04) as shown below.

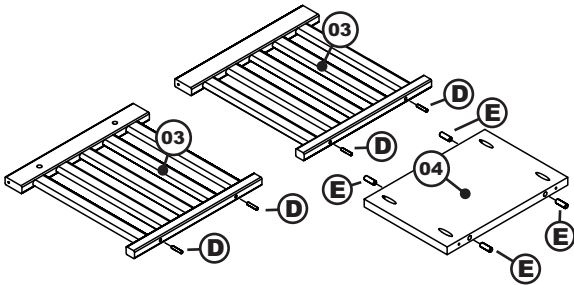

### STEP 3

Attach first side panel (03) to side table aligning the dowels with the holes in the apron. Be sure the panel is centered before tightening the wood screw (F).

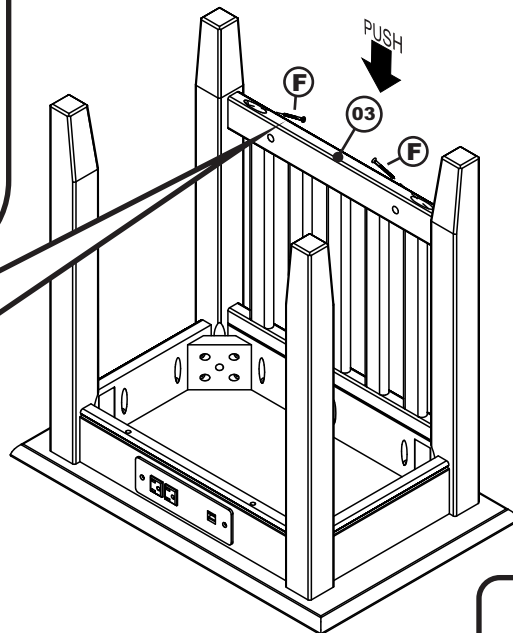

note: panel in center

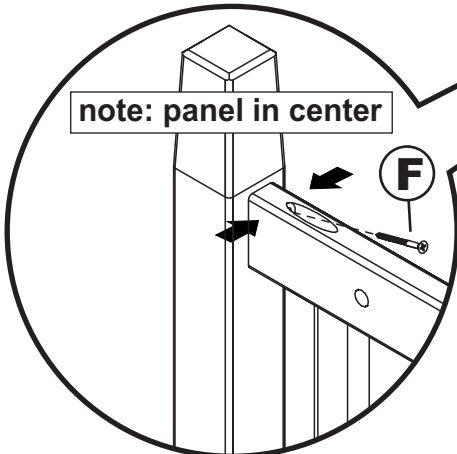

## CHAIR SIDE TABLE CHARGING STATION

### Step 4

Attach second side panel (03) the same as the first but place the lower shelf (04) in position by aligning the wooden dowels with the holes in the side panel.

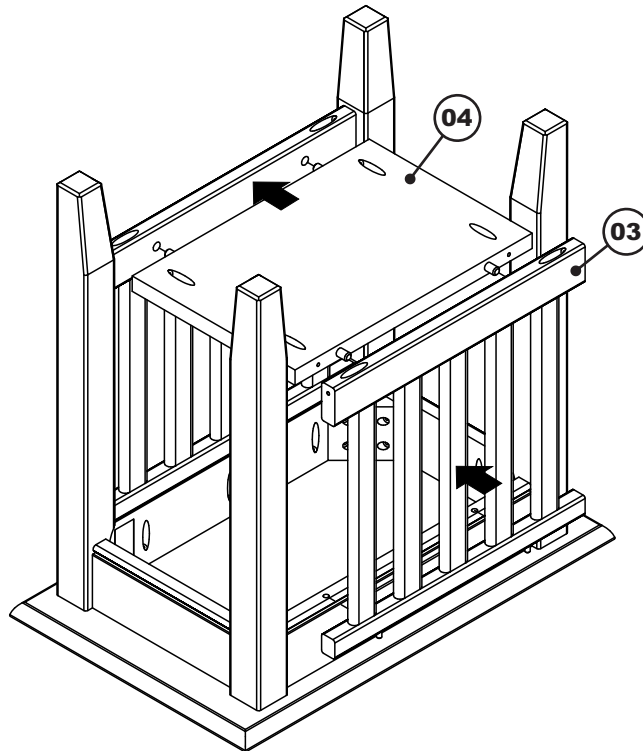

### Step 5

Apply pressure to eliminate any gap between the lower shelf and the side panel and fix in place using wood screw (F).

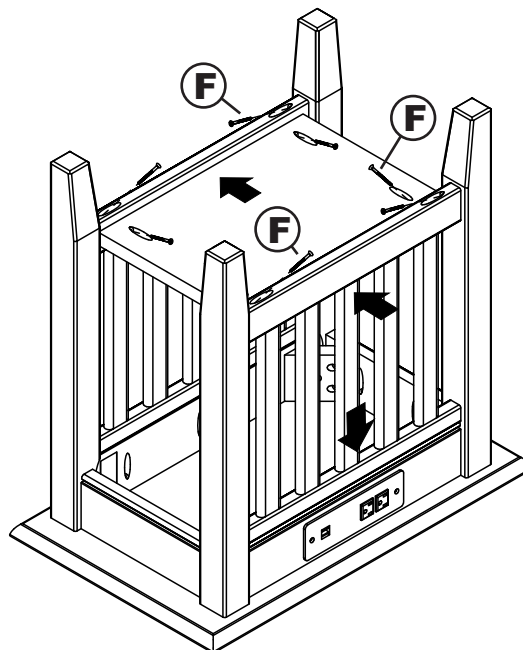

## Congratulations!

Your side table is now ready for use.

To ensure lasting safety, we recommend that you periodically check that all screws are tight and all parts are secure.