

3-Piece Rocking Wicker Bistro Set

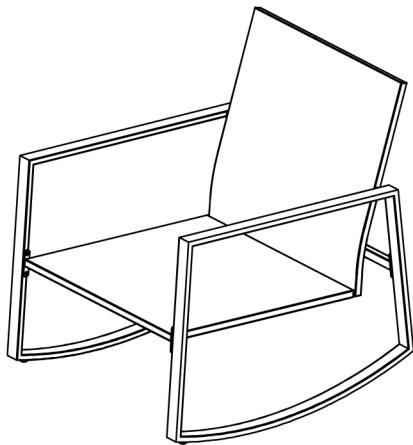

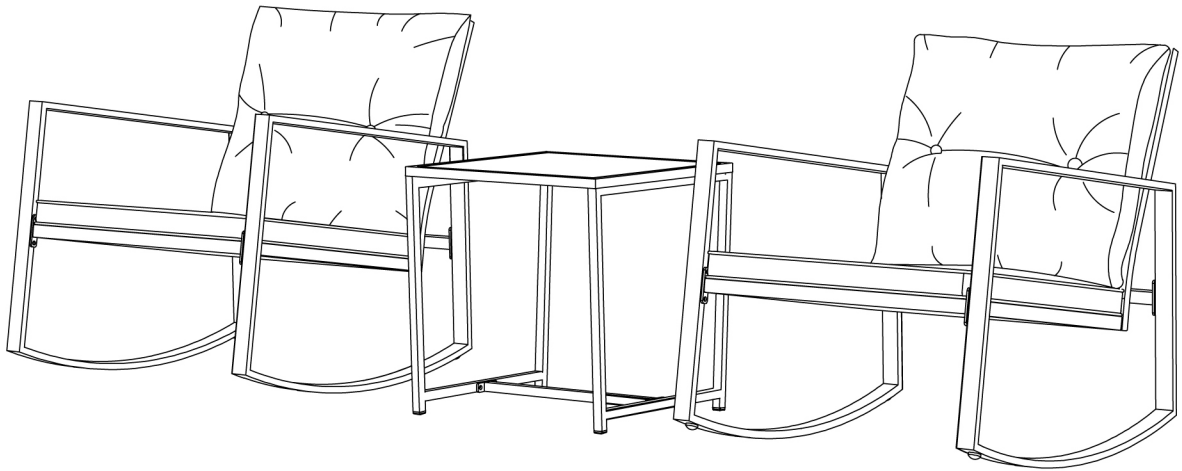

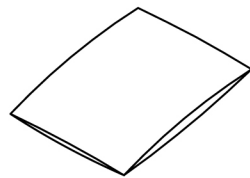

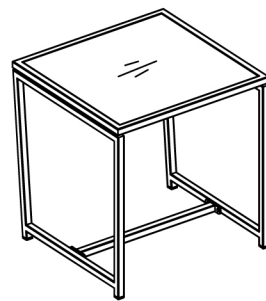





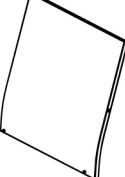

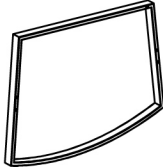
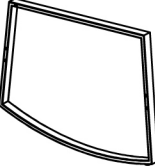
x2



Assembly
bag

1SET/CTN

Rocking Chair (Do this twice)

Item no.	Reference Image	Description	Qty.
A		Seat Back	1
B		Seat Base	1
C		Left Arm Rest	1
D		Right Arm Rest	1
E		Seat Back Support	1
F		M6 x 35 Socket Head Cap Screw	2
G		M6 x 15 Socket Head Cap Screw	8
H		Flat Washer	14
J		4-mm Allen Key	1
K		M6 x 45 Socket Head Cap Screw	2
L		wrench	1
M		Nut	2
N		Riser	2

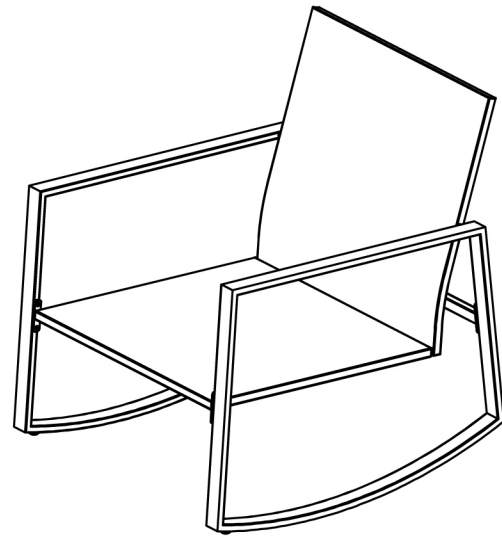

1

Attach the seat back (A) and the seat base (B) using a M6 x 35 socket head cap screw (K) with a flat washer (H) then place the screw cover (I) over it. Do this in two places.

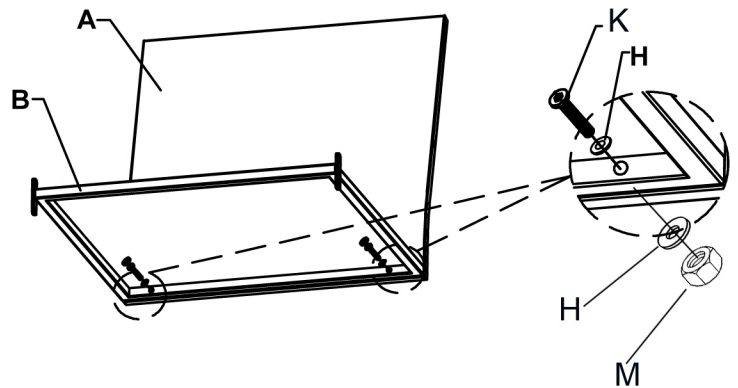

2

Flip the assembly upside down. Secure the arm rests (C & D) to the seat base (B) using M6 x 20 screws (G) with a washer (H) then place the screw cover (I) over it. Do this in four places.

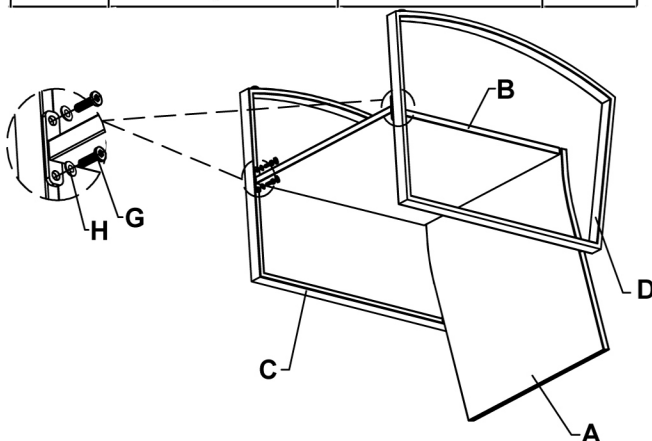

Rocking Chair (Do this twice)

3

Flip the assembly back. Secure the seat back (A) using M6 x 35 screws (F) with a washer (H) then place the screw cover (I) over it. Do this in two places.

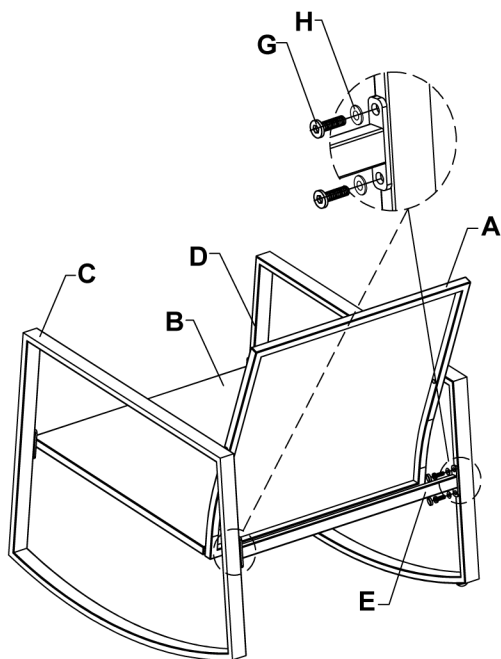
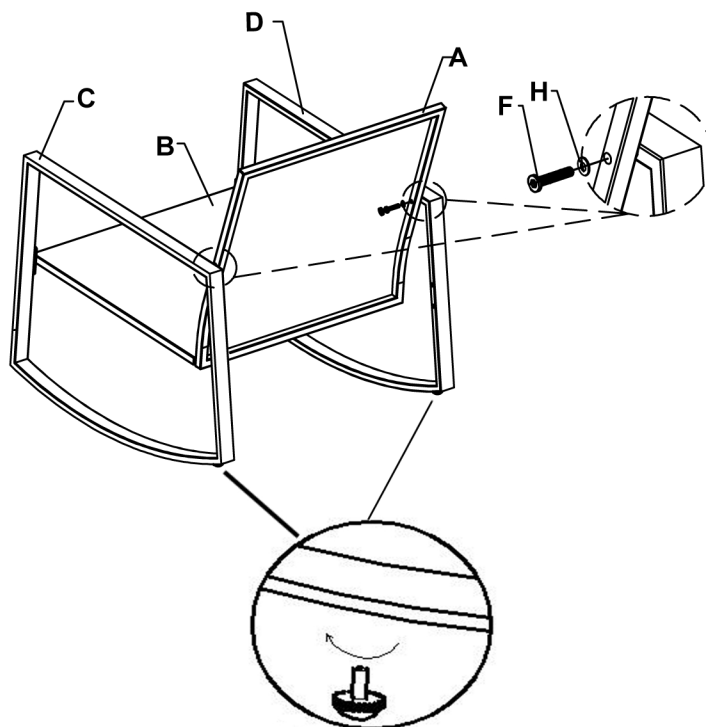





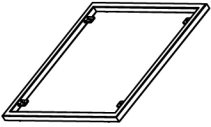
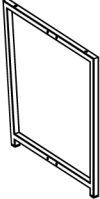

4

Attach the seat back support (E) using M6 x 20 screws (G) with a washer (H) then place the screw cover (I) over it. Do this in four places.

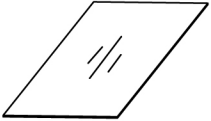
Tips: Do not tighten all screws fully before the item is well assembled.

Coffee Table

Item no.	Reference Image	Description	Qty.
A		Table Top	1
B		Legs	2
C		Leg Support	2
D		Glass Top	1
E		M6 x 35 Socket Head Cap Screw	4
F		M6 x 15 Socket Head Cap Screw	8
G		Flat Washer	12

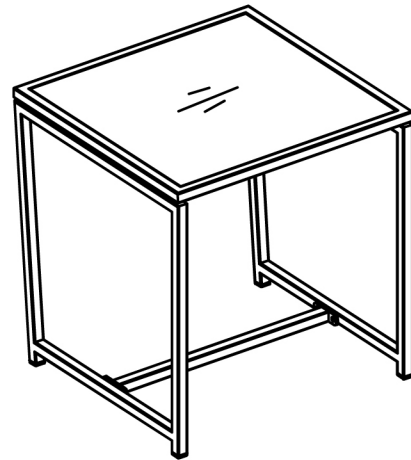

1

Flip the assembly upside down. Attach the table top (A) and the legs (B) using a M6 x 35 socket head cap screw (E) with a flat washer (G) then place the screw cover (H) over it. Do this in four places.

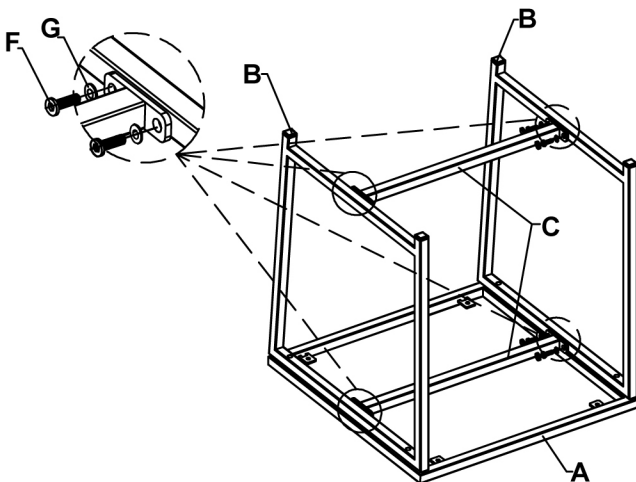
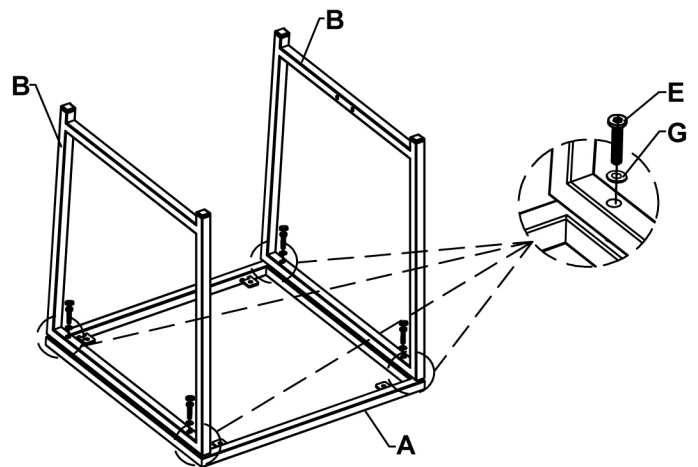

2

With the assembly still flipped over, attach the leg supports (C) using M6 x 20 socket head cap screws (F) with a flat washer (G) then place the screw cover (H) over it. Do this in eight places.

Coffee Table

3

Flip the assembly back then place the glass top (D) on it.

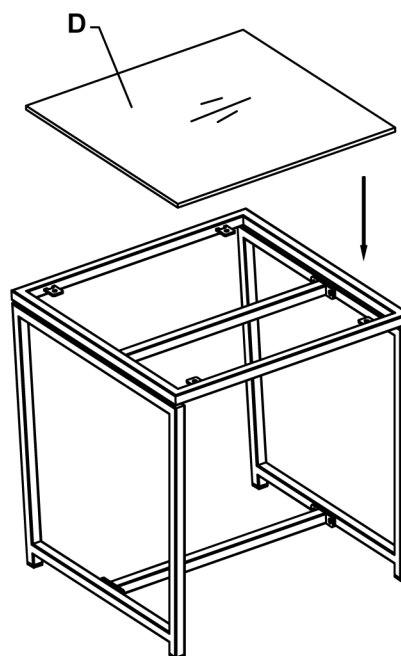

Tips: Do not tighten all screws fully before the item is well assembled.